

Civic Spaces, Social Ecosystems

INTRODUCTION

p.5

•

CASE STUDIES

1: Cultural Centre - Artist lead

Chats Palace

p.13

2: Social Enterprise - Artist lead

Stour Space

p.25

3: Traditional Town Hall / Church Hall
The Old School Rooms & Round Chapel

p.37

4: Health and Community Centre

Bromley by Bow Centre

p.49

5: Interim Use Centre

Hub67 / The Yard Theatre

p.61

6: New Development Civic Space

The Green Man, Phoenix Community Housing Association

•

CONCLUSION

p.85

Introduction

Outlining background, research introduction, case studies and evaluation principles.

Civic Spaces – Social Ecosystems

Background

The London Legacy Development Corporation (LLDC) commissioned public works to undertake the research study ‘Civic Spaces’ as a piece of research into existing, contemporary models of varying types of community spaces in London. The study will act as guidance for the delivery of successful civic spaces in future developments within and around Queen Elizabeth Olympic Park. Findings may also inform the LLDC’s advisory role, procurement and delivery strategy for these spaces.

Introduction

With the changing economic landscape and increasing trend to privatise public spaces and facilities, the understanding of what constitutes a civic space is shifting. At a time where other public institutions are stretched to support its citizens, civic spaces can take over multiple roles to add to the wellbeing and life of the citizens. To better understand these roles and current trends, this study analyses six London-based case studies, all with differing civic focus and program.

The term civic describes the multiple relationships between the citizen and the city. We are specifically interested in relationships which do not rely primarily on passive, consumption based models but instead enable citizen to take a more active part in the city and in the communities they belong to; spaces which mediate the city and create closeness between the many different groups that occupy it. In this context, we defined social ecosystem as the multilayered, dynamic relationship among and between the tenants, users, civic space and the surrounding area.

The degree to which these spaces allow for multiple relations between the citizen and the city will set the measure of success. The study will set out best practice and list key ingredients including, crucially, a commentary about stewardship, ownership, management and economic models. Furthermore, the study will provide a series of recommendations on potential management / delivery models and other considerations opportunities.

Case Studies

This study maps out six successful spaces, which facilitate a multi-layered understanding of civic life and the spaces that help foster it. Three examples are located in new developments and four best practice examples are from established town centres. The projects and spaces are of varying scale, age, infrastructure and history to give a true representation of types of initiatives present across London. To understand them each holistically, they all have been analysed spatially and against their programme, outreach, economy and governance structure.

The following six case studies were identified:

1. Chats Palace, an arts-led cultural community centre;
2. Stour Space, an creative minded organisation in a warehouse;
3. The Old School Rooms & Round Chapel, a traditional town hall;
4. Bromley by Bow, an health and art centre;
5. Hub 67, an interim use project;
6. The Green Man Community Centre, a new development.

Methodology

The study consists of precedent studies of six successful Civic Spaces (i.e. D-Class uses) focusing on viability and key principles (which can slot into SPD's as they get completed).

This part is primarily based on first hand interviews with project champions and managers of the selected case studies, as well as evaluation of documents supplied by the project team.

Conclusion and Recommendations

At the back of each case study we have concluded with unique 'Do's and Don'ts' for that particular study. In the final conclusion we have identified eight principles as the most relevant learning outcomes from all the projects, with the help of most applicable case study examples.

Evaluation Principles

1. Social ecosystems

This draws from the definition of ecosystem as the network of interactions among and between organisms and their environment. In this context, we define social ecosystem as the multilayered, dynamic relationship among and between the tenants, users, civic space and the surrounding area.

2. Specific function or cultural driver

Discusses the need for a space's programme or offerings around a common, specific theme rather than with particular focus.

3. Responsive governance

Refers to an inclusive government structure that considers sug-

gestions and ideas of all involved in the decision making process, rather than rigidly sticking to the initial agenda, to ensure the best possible results for their evolving community.

4. Being local

Discusses the role of the use of local resources (for example labour, knowledge or materials) in building a wider strong community to an initiative.

5. Anchor tenants

Refers to contractual tenants that bring a fixed income flow and possibly footfall to a project, often to subsidise no/ low profit initiatives for community benefit.

6. Creative funding

Discusses the use of innovative ways of generating funds for a project (cross-subsidy, grants, events), which is particularly important with ever decreasing government funds.

7. Time, ownership and trust

Discusses the role and importance of time in growing a successful community project.

8. Desired Spatial Qualities

Discusses the different spatial qualities that are essential or desirable for a contemporary Civic Space, with examples.

This evaluation is followed with a more generic summarised set of 'Do's and Don'ts' to act as guidance to set up new Civic Spaces.

Spatial, Revenue and Location Comparison

1. CHATS PALACE

Total Area: ~800sqm
Total revenue: + £160K per year
Location: Hackney

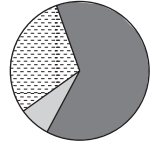
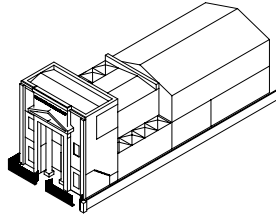

2. STOUR SPACE

Total Area: ~1160sqm
Total revenue: n/a
Location: Hackney Wick

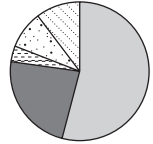
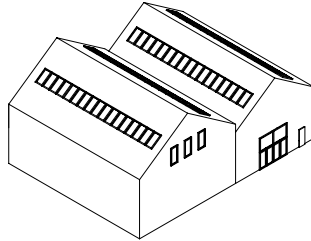

3. THE OLD SCHOOL ROOMS AND ROUND CHAPEL

Total Area: ~1000sqm
Total revenue:
+ £225K per year
Location: Hackney

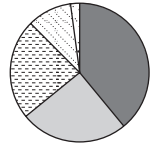
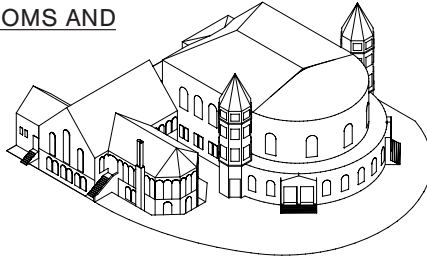

4. BROMBLEY BY BOW CENTRE

Total Area: 12340sqm
Total revenue: n/a
Location: Brombley by Bow

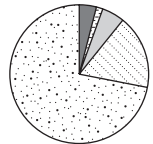
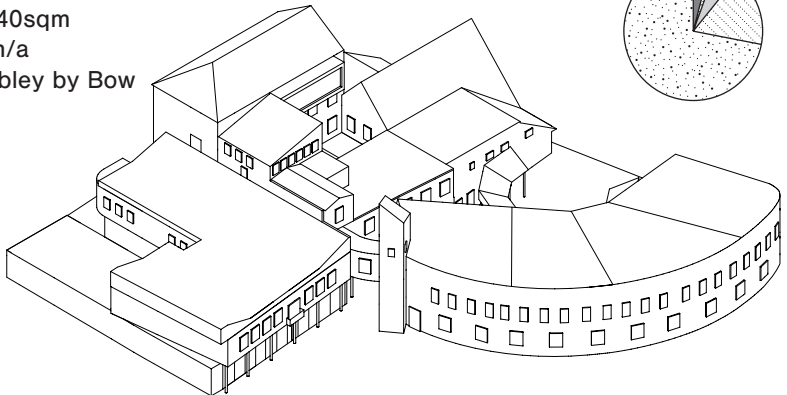

5. HUB 67

Total Area: 135sqm

Total revenue: n/a

Location: Hackney Wick

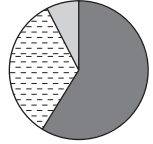
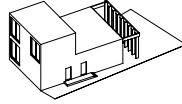



6. THE GREEN MAN

Total Area: 5590sqm

Total revenue: n/a

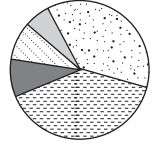
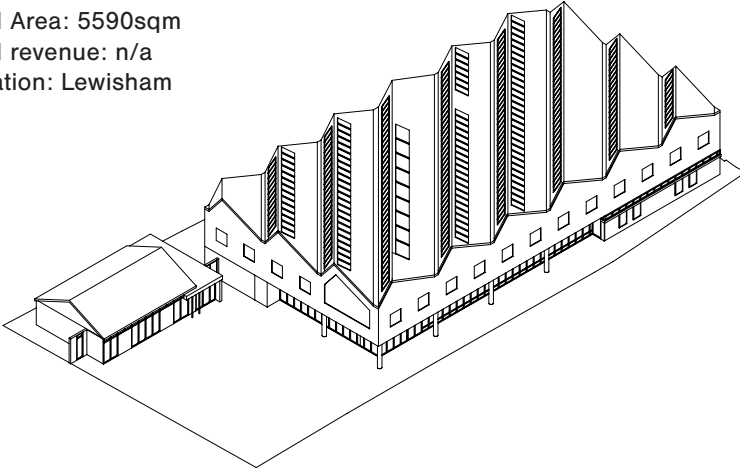
Location: Lewisham



 Anchor Tenant

 Circulation / Services

 Flexible Spaces

 Outdoor Area

 Staff Offices



Chats Palace

A cultural community centre in the heart of Hackney that features a theatre, dark room and concert space.

1.

Uses theatre and entertainment as a cultural driver to bring people in.

2.

Long-term provider of cultural activities for disadvantaged groups in Hackney's neighbourhood.

3.

Prominent location on high street and easy access with public transport.

The Story

Chats Palace is a cultural centre located in the heart of Hackney. Established in 1974 by a group of socially minded activists with a background in theatre and live art events, Chats Palace occupies the old Homerton library, a striking building along the busy Chatsworth Road. With such a strong social history, it is an establishment that has become embedded within its surroundings and local culture. Predominantly known for its theatre, its rooms are also available for hire for community activities, rehearsals, concerts, theatre, private parties, film shoots and events.

History

The building that hosts Chats Palace was established in 1913 as a Carnegie library for the betterment of the people of the East End. The library closed and in 1974 a joint campaign between the committee for Hackney Marshes Fun Festival and the local community persuaded Hackney Council to allow the library to be reclaimed and transformed into an arts centre.

Funding

A small grant from Greater London Arts Association funded a programme of live arts events and paid the salary of a festival coordinator for the first year in 1976. In order to secure their presence, Chats Palace has been registered as a charity and company limited by guarantee since 1981 with a board of 8 trustees. They currently rely on around £30-40k of funding per year and money earned through letting and hiring out spaces (around £120k) to pay for the upkeep of the building and three full time salaries. The constant presence of committed employees and local community groups in retaining this ethos has strengthened the centre's resilience. Currently there are three full-time staff.

Building Typology

Chats Palace holds a balance between community centre and progressive theatre. The impressive stature of the building that gives it presence on a bustling high street, puts them at the heart of a thriving and diverse community. They have a large ground floor theatre with a capacity of 250, with numerous productions every year, as well as a bar open five days a week with regular live music, a large flexible rehearsal space, a meeting room and Photochats, a darkroom - all available to hire. Alongside these facilities are interspersed office spaces for the three full time staff members that work in the building. All these numerous functions are able to offer a host of different spaces, facilities and activities to the local community and beyond.

Community

A firm belief right from the start, that entertainment has the ability to play a strong part in bringing communities together and creating new connections between communities, Chats Palace was founded primarily as an arts centre to provide an alternative to the sterile community centres located within the nearby estates. However, to maintain close local relationships, they sought to acknowledge the presence of these community centres by performing a travelling play within them, written about the local area. Situating themselves outside the comfort of their own building determined where and what kind of Civic Space they were to become.

Address:

42-44 Brooksby's Walk, E9 6DF [Hackney]

Opening Hours:

Office hours: M-F 10am - 5pm

Kiosk: Wednesday & Thursday 7pm - 12am, Thursday & Friday 7pm to 1am

Sunday 6pm - 11pm

Program / User groups

Youth

Chats Literacy Project was funded by the Local Borough of Hackney Main Grants. The project involved three local schools – Kingsmead, Daubeney and Rushmore.

Immediate Theatre run youth workshops and their youth drama club for young people living on local estates.

Trad Academy music / dance club + Ballet classes (regular)

Elderly

Song Sharing was started by local artist and archivist, Andrea Sinclair for local people over 55. Delivered in partnership with SOAS, this project created an archive of songs from the past that may otherwise have been forgotten.

Disability Specific

Joy of Sound put on music sessions for people with disabilities every Tuesday morning. A funding award enabled them to work with local musician Peter Thomas.

HiP Hackney (Hackney Independent Forum for Parents/Carers of Children with Disabilities) made Chats Palace their main Hackney venue, holding workshops and discussions with professionals in the special educational needs field.

General

Growing Communities uses Chats Palace as the Homerton pick up point for their organic vegetable scheme.

Homerton Hospital continued its monthly meeting at Chats Palace for people who have recently left the care of Mental Health Services.

Photochats offers local photographers access to professional standard dark rooms and to produce a programme of exhibitions drawing on the Chats Archive.

Swing Dance classes (weekly)

Pan intercultural choir

1.

People come
for the theatre
and concerts



2.

People then get
involved infor-
mally with other
programs

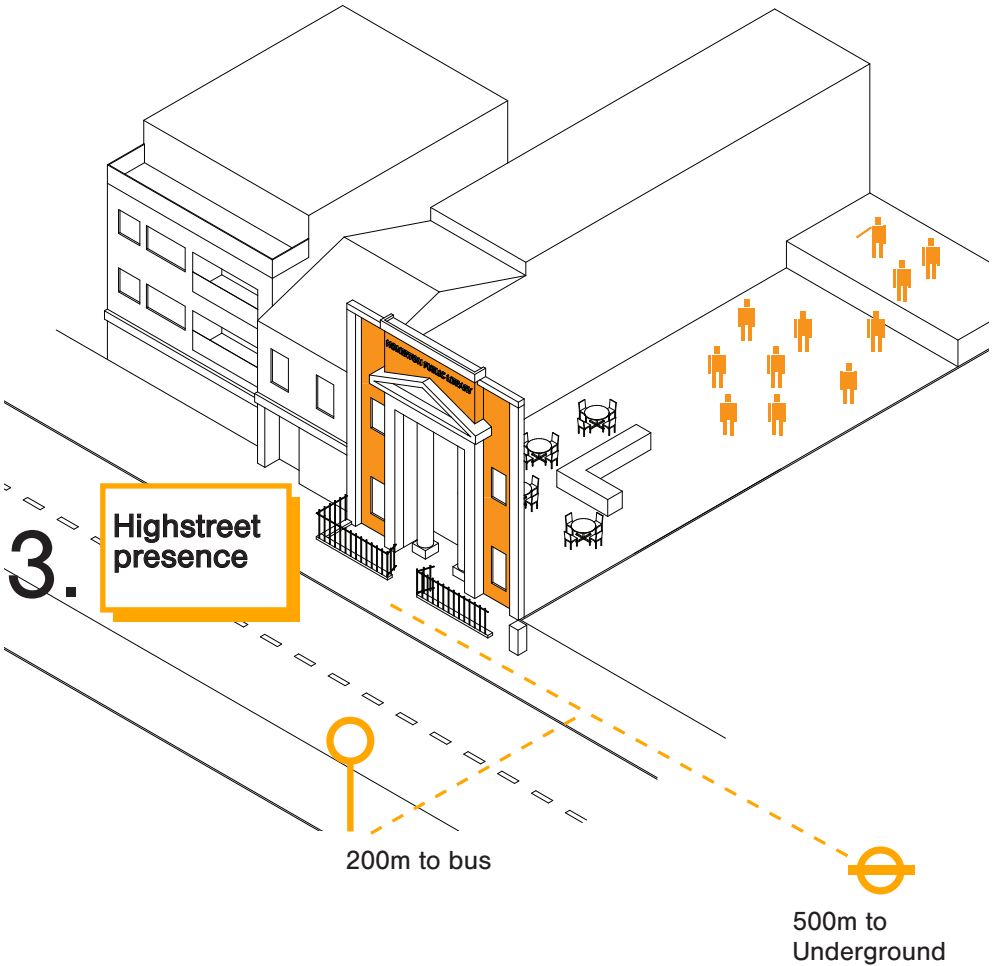



12. Performance: the theatre



4. Flexible Hired Space: Meeting Room



9. Anchor Tenant: Kiosk Bar



12. Flexible Hired Space: Theatre



10. Flexible Hired Space: Gallery



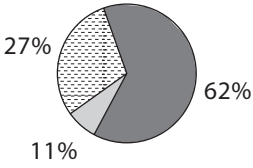

6. Flexible Hired Space: The Studio

Spatial layout



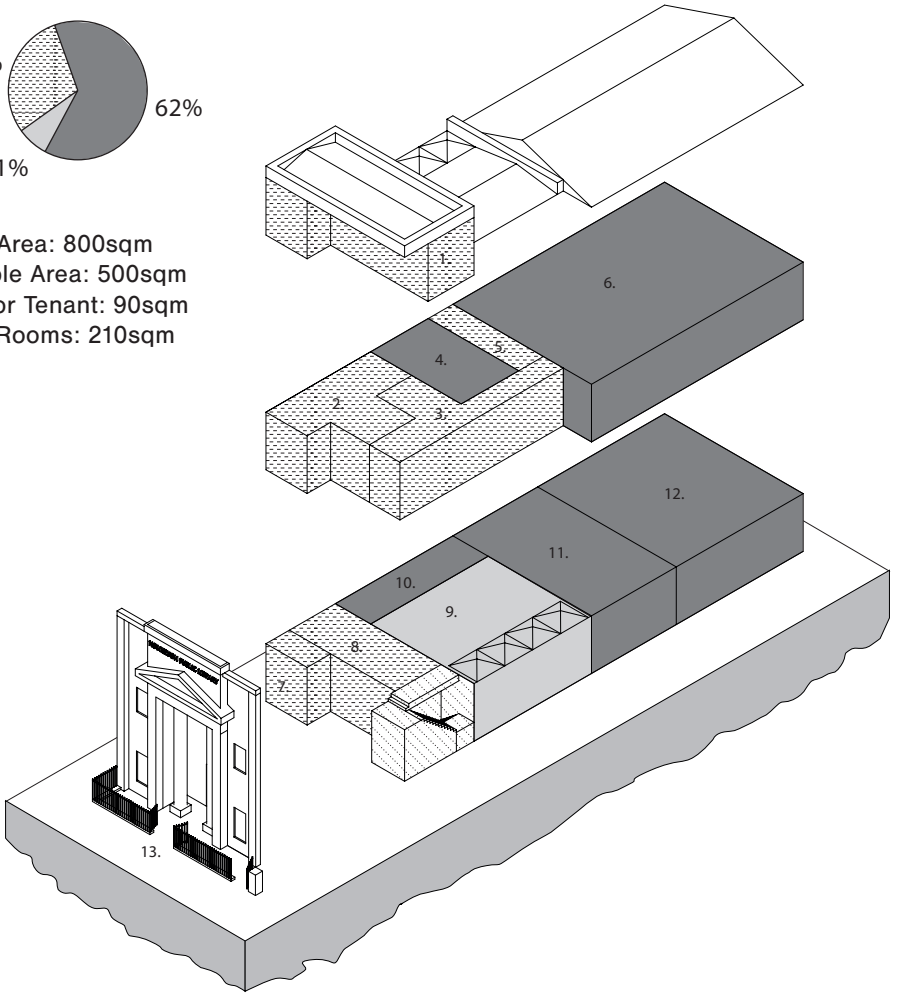

Total Area: 800sqm
 Flexible Area: 500sqm
 Anchor Tenant: 90sqm
 Staff Rooms: 210sqm



 Anchor Tenant
 9. Kiosk Bar

 Flexible Space
 4. Meeting room
 6. The Studio
 10. Gallery
 11. Photo Studio
 + darkroom
 12. Theatre

   Other
 1. Storage
 2. Staff office
 3. Lobby
 5. Staff kitchen
 7. Staff office
 8. Lobby
 13. Outdoor seating area

GOVERNANCE & ECONOMY

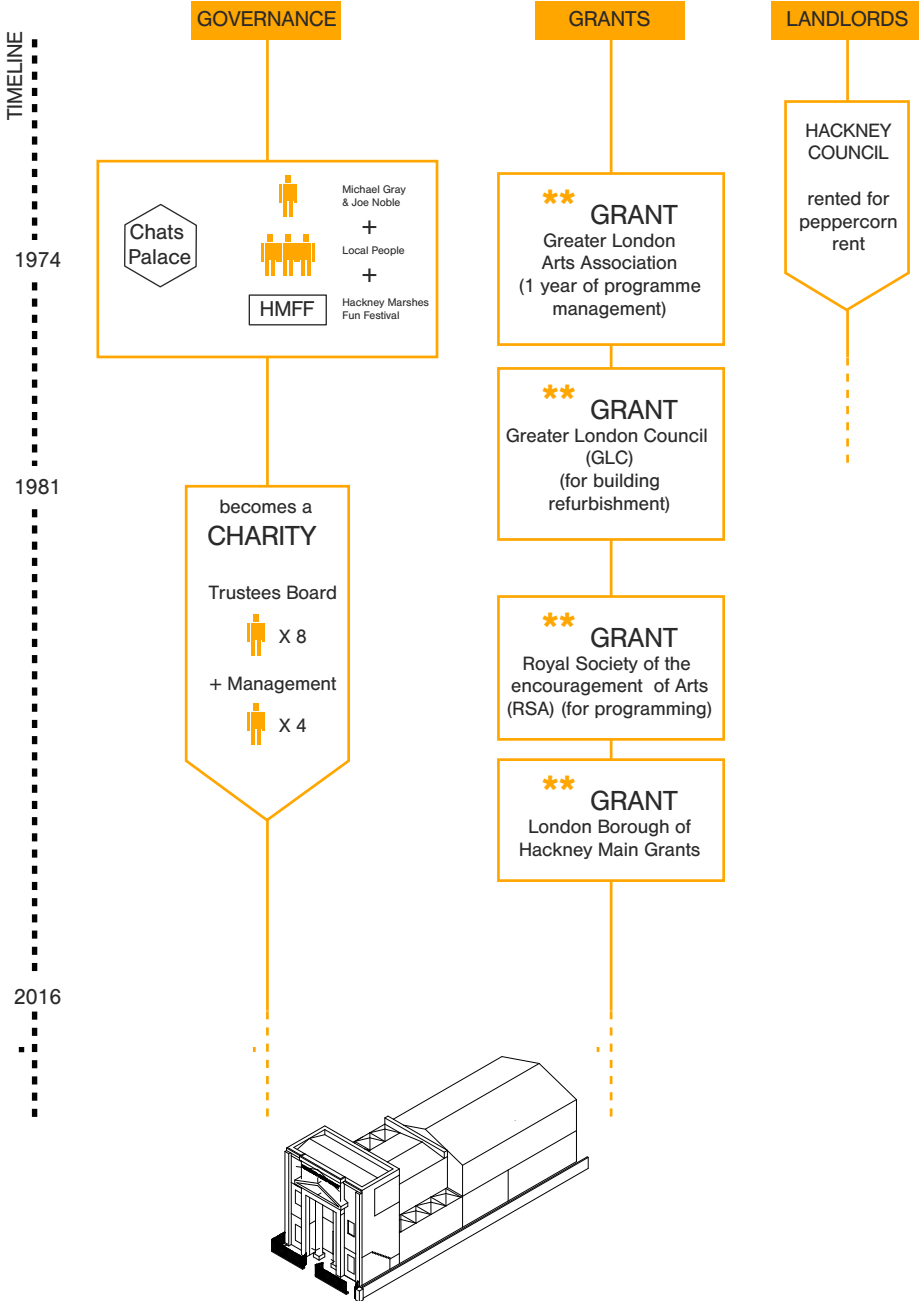

GOVERNANCE & ECONOMY

CURRENT INCOME STREAMS

INCOME

£ FIXED RENT
Anchor Tenant
Kiosk Bar

£ VARIABLE RENT
Space for hire
- meeting room
- studio
- gallery
- photo studio
- theatre

🕒 VOLUNTEERS

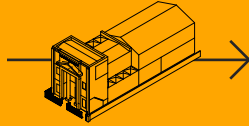

£ BUILDING
MAINTENANCE

£ WAGES
4 full-time staff

£ COMMUNITY
PROGRAMMING

£ RENT
peppercorn rent
from Hackney Council

OUTGOINGS

CURRENT GOVERNANCE

LANDLORD

HACKNEY COUNCIL

BOARD OF
TRUSTEES

MANAGEMENT



Lara Gasch
(Chair)



Jacquetta May
(Vice-Chair)



Victor McAllister
(Treasurer)



Clr Ian Rathbone
(LBH appointee)



Clr Rebecca
Remnison



Gary Bridgewood



Mike Brooks



Richard Pitkethly



Laura May Lewis
General Manager



Lucy May
General Manager



Peter Young
Photochats



Kiosk Bar

Concluding

Do's

+
The specific focus on arts provided the perfect medium to bring people together and create a platform for the project to grow on different levels.

+
Being a constituted charity and thus having a constant presence of committed employees and local community groups retained the ethos of Chats Palace through the years.

+
The flexibility of the space and its character allow many different events and initiatives to happen and establish over time. This also facilitated Chats Palace to establish itself as a prominent cultural institution.

+
The management ensures that the programme meets the needs of different vulnerable groups and others, providing a wide range of cultural activities for all ages.

Don'ts

-
Due to the listed condition of Chats Palace, the current management restrict the anchor tenants to advertise their businesses on the main facade. This directly impacts negatively on the possibility for the tenants to fully benefit from this High Street location.

Impact

Having been engrained in the community for many years allowed it to develop organically and to establish as an important cultural venue in the area. Chats Palace filled the gap of such a space for the community, first establishing in an informal matter as a socially minded, activist project, but then succeeded in providing a long-term solution for a lack of cultural, art and community establishment in Hackney. The current focus on a well-established and diverse creative programme, running alongside the socially minded community agenda, together with the favourable location right in the middle of East London, enabled the creation and extension of a wide network of initiatives, users and professional collaborators.

OTHER SIMILAR EXAMPLES

ALBANY THEATRE: Based in the heart of Deptford, the Albany is a performing arts centre with a history stretching back to the nineteenth century. Over the last few years, we have emerged as a new type of arts venue, very much driven by the cultural diversity and creative mix of South East London. Involving people, through participation and partnerships, is central to their work and their mission. [www.thealbany.org.uk]

ARCOLA THEATRE: Arcola's programme is locally engaged and internationally minded. They believe that diversity makes for better art, and for a more flourishing arts scene. Every year through Arcola Lab, they provide 28 weeks of free rehearsal space to emerging, ethnically-diverse artists. 50% of the plays in our last season were written and directed by women. [www.arcolatheatre.com]



Stour Space

An abandoned warehouse turned multi-functional creative venue, with studios, galleries and a cafe.

1.

*Clear mission:
Everything they do
aims to impact the
creative economy
and knowledge.*

2.

*Offers free
exhibition space to
local artists.*

3.

*Developed into
a platform for
local businesses
and residents to
exchange ideas.*

The Story

Stour Space is a socially minded organisation offering exhibition, performance and studio space for the development of creative enterprises. The organisation is committed to art and culture as a catalyst for social change, particularly in areas of economic deprivation and urban regeneration. Stour Space promotes and supports local creative businesses, and works in collaboration with many local enterprises, residents, artists and committees. There are currently over 36 tenants in over 20 rentable studios.

History

Founders Rebecca Whyte and Neil Horden set up Stour Space in 2009 in a warehouse that had been abandoned for 15 years. It is a company limited by guarantee with charitable status, because the open nature of the project made it difficult to set it up as a charity. The first year was just about providing affordable, well-sized studio space and building a community around them. With the (still on-going) changes in the area through the Olympics the management started to react to the needs of the community providing a platform for exchange and conversations between different parties.

Funding

The founders self-funded the deposit and the first few month's rent for the project, and all the refurbishment work happened in-kind with local volunteers. Also, all the refurbishment was done with locally sourced, recycled materials. The project's finance remains a struggle and because of their short, uncertain lease contract they have not been able to apply for any additional funding. In order to generate more income and to maintain low-cost makers spaces they have started to host weddings and corporate events.

There are currently 14 staff members (including cleaners and bar staff), all locally based, working on a self-employed basis.

Building Typology

Stour Space is a warehouses situated between two adjoining buildings. The space now includes a gallery, Café, shop, 20 studios, a project/function room and offices. The directors successfully managed to have the property listed as an asset of community value, after it became clear that the building's owner intended to sell off the property for redevelopment. The space is now leased as £20 sq. ft. per year.

Community

The gallery space is given pro bono for one month to any local artist who wants to exhibit. The team also offers to curate the artist's work and to do any promotional marketing that they might require. This helps local artists to gain a presence within the artistic community in East London and beyond. Stour Space has also acted as a business incubator for makers of the local area. It is also focused on supporting local labour and produce. For their initial building works they used reclaimed materials from the neighbourhood and the cafe promotes local produce from Crate Brewery, Re-juice, Organic Wick and the E5 Bakery. They also work with local schools and colleges on training around community arts and offer them free use of their space. Key to their success is a flexible management always open to new ideas. This allows for trust to build up between individuals, projects and initiatives, and hence for all involved to organically grow with a mutual benefit.

Address:

7 Roach Rd, Tower Hamlets E3 2PA

Opening Hours:

Mon–Fri 8am – 5pm

Sat–Sun: 9am - 5pm

Program / User groups

Exhibitions / The Gallery

Through a submissions-based process Stour Space exhibits and promotes the work of local emergent artists and enterprises, and encourages new innovative work for public engagement. Exhibitions are held on a monthly basis in connection with Time Out First Thursdays, promoting a philosophy to collaborate on new ideas, and generating the potential for artists to realise large-scale exhibitions.

Art Shop

Stour Space also handles all art sales made in the gallery, as well as the administration, management and promotion of the exhibition. This service has also been available to studio tenants that require additional support to locate commissions and source networking opportunities.

Other Programme

Senzala Capoeira | Weekly Sub

Quiet Monday - Yoga and Meditation | Weekly

Stour Space Weekenders

Stour Space weekenders happen on numerous occasions and bank holidays throughout the year. They are weekends of music, food and celebrations that attract lots of people from the local area, but brings people from afar, creating further interest in the space.

Operates as a mutual ecosystem and support network for all parties involved !

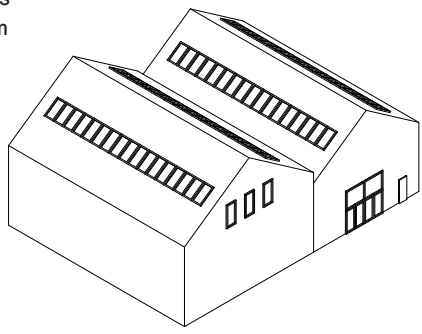
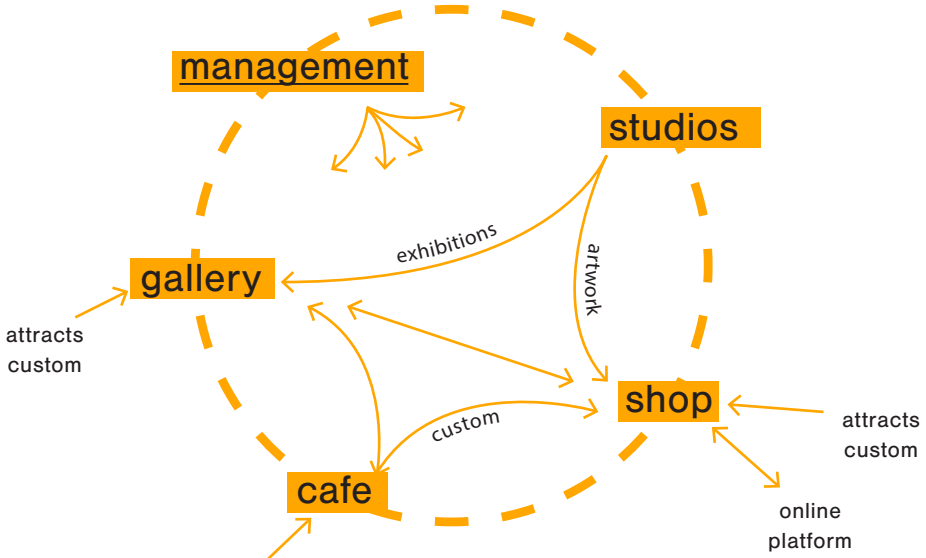

+ STRONG LOCAL LINKS



Entrance and front space



Gallery



Main atrium



Shop



Flower workshop



Chat's Yoga on Mezzanine

Spatial layout

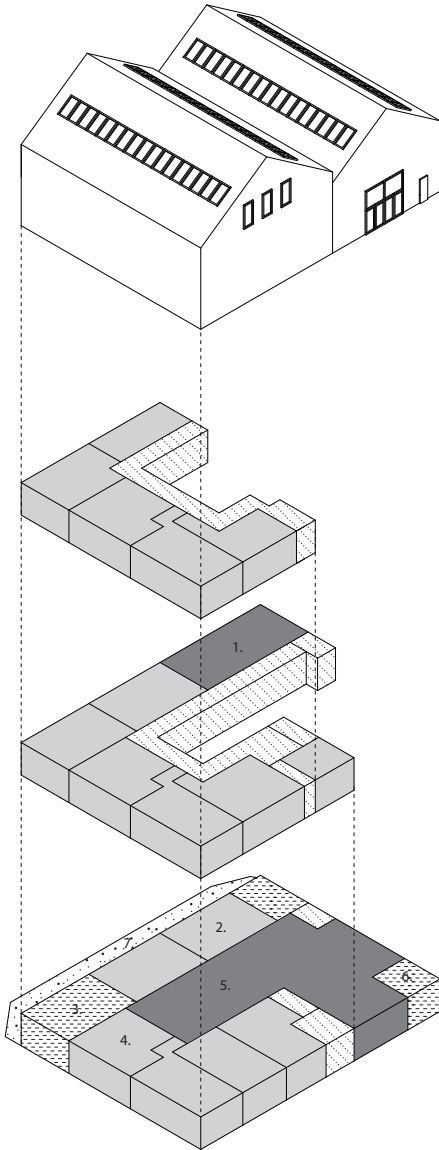

Total Area:
830sqm

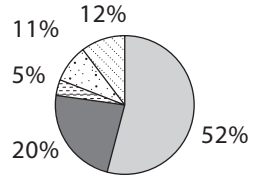

- Anchor Tenant
- Flexible Spaces
- Staff Offices
- Circulation / Services
- Outdoor Area

GOVERNANCE & ECONOMY

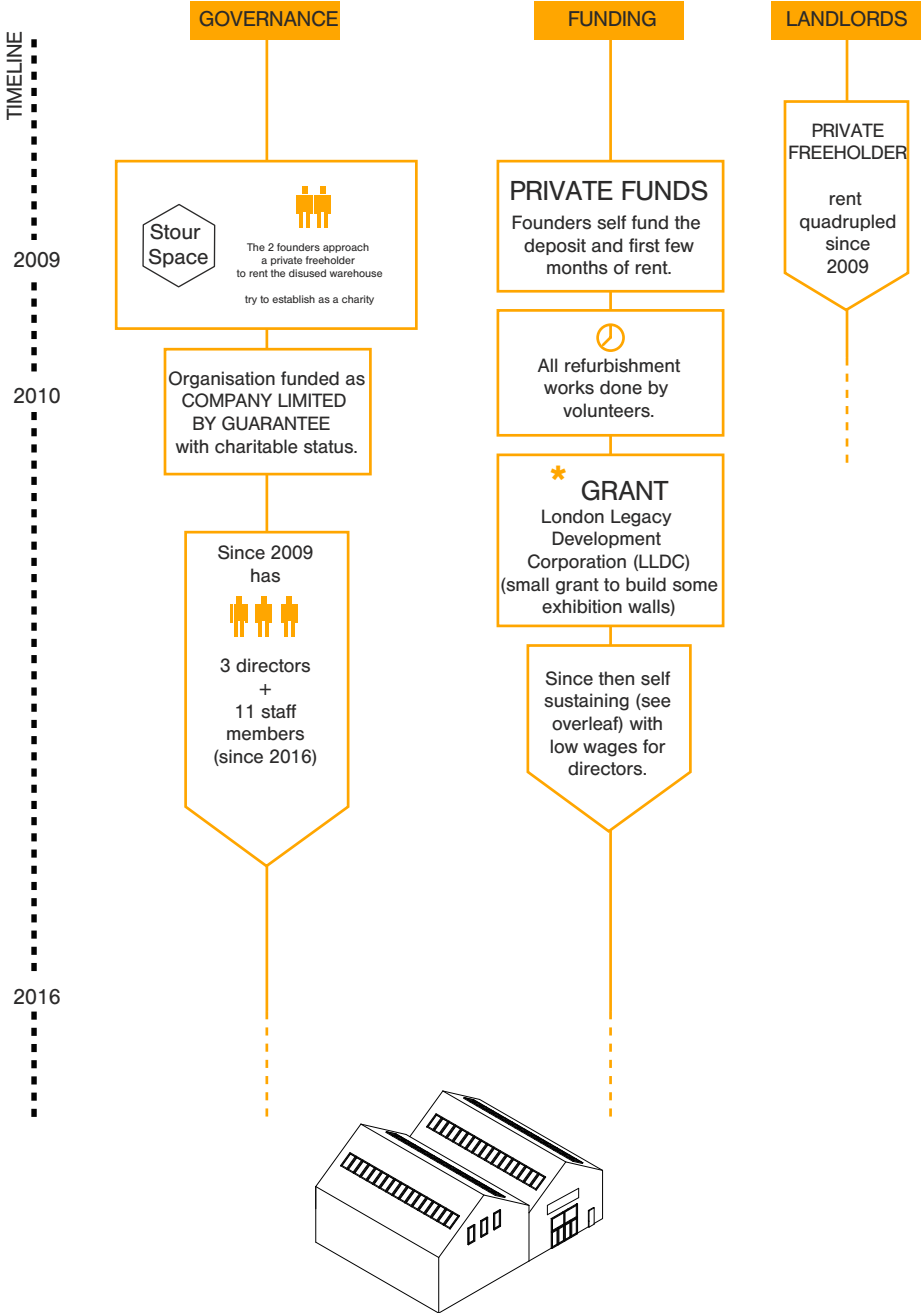

GOVERNANCE & ECONOMY

CURRENT INCOME STREAMS

INCOME

£ FIXED RENT - 50%
 - 36 tenants in 20 affordable studio spaces
 - The Counter Café

£ VARIABLE RENT - 50%
 - Gallery Space for hire
 - multifunction room for hire
 - income from the shop/commissions

🕒 VOLUNTEERS

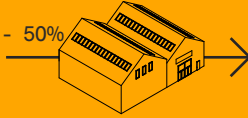

£ BUILDING MAINTENANCE
 (minimal / volunteers)

£ WAGES
 3 directors and 11 other staff (incl bar and cleaning)

£ RUNNING COSTS

£ RENT
 quadrupled since 2009

OUTGOINGS

CURRENT GOVERNANCE

LANDLORD

PRIVATE LANDLORD

BOARD OF TRUSTEES

CURRENTLY INFORMAL -
 They want to formalise a board this year.

MANAGEMENT AND STAFF



Neil Horden
 Director & Founder



Rebecca Whyte
 Director & Founder



Juliet Can
 Director

+

11 staff members

Concluding

Do's

- + The whole space focuses on one key topic: culture comes first. This promotes a clear reason to visit the space and enables it to grow as a community with a shared interest.
- + Cross-pollination and cross-subsidy have cultivated an innovative portfolio of initiatives.
- + Transparency to all members about progress, decisions and risks is important to create an inclusive environment and for the space to grow 'together'.
- + Old buildings need love. Including the makers/ tenants in the renovation is a great way to generate a sense of ownership of a space.

Don'ts

- The short lease contract puts the project into a vulnerable position with uncertainty of sustaining in the future. Constant lease negotiations have prevented the management team to submit normally invaluable funding grants.
- Wages are low and the management team cannot solely rely on them for their main source of income.
- The project was fitted into an old industrial unit with minimal fit-out budget and hence has high levels of energy consumption.

Impact

How do you create communities around the creative economy and how does this impact health, education and safety in an area? Stour Space's management and initiatives all operate in a mutually supportive way to one another. This has created a strong sense of community and interconnectedness for its users.

Within the cultural and creative context the impact of the project is significant for Hackney artists and groups; this was only possible because the project made the arts its focus. Contrary to that this means that the project is particularly directed at one user group and thus limits its capacity to reach out to some members of the local community. Beyond this, the management have advised other institutions like the Danish Council, the Taiwanese Institute and others from Japan, Brazil, Sweden and Liverpool to set up similar types of spaces that provide different ways of adding social value to a community. Key is, that they have realised that their model does not need to be centred around the arts or making, but could be applied to a different focus like music, health or other. This year, the management hope to develop Stour Space as a trust so they can develop this into a formal, paid advisory role for other projects in the future.

OTHER SIMILAR EXAMPLES

COPELAND PARK & THE BUSSEY

BUILDING, Peckham, has a vast range of occupiers, including creative arts, artist's studios, theatre groups, live music venues, fitness studios, and faith groups. In 2009, it was saved from becoming a tram depot site and since then it has lost many of its industrial uses. It now houses the creative quarter of Peckham. [copelandpark.com]

BUILDING BLOQS, Enfield. Provides diverse facilities and resources that enable professional makers to nurture and grow their businesses. The Building Bloqs open workshop in Enfield offers 11,000 sq. ft. of space with professional infrastructure for makers and incorporates a cafe and studio space. [buildingbloqs.com]



Round Chapel and the Old School Rooms

A church with connected community spaces providing essential neighbourhood support and work space.

1.

Provides essential nursery spaces for neighbourhood.

2.

Renting workspace cross-subsidises community initiatives.

3.

Continuing struggle because of separate governance and lack of common theme amongst tenants and projects.

The Story

The Round Chapel is a large former chapel with associated buildings located in the heart of Clapton. Since 1991 the chapel has been separated from its associated buildings, which are now called The Old School Rooms (TOSR). The Old Schools Rooms act as a place of worship and its building is available for the benefit of the surrounding neighbourhood, whilst the chapel itself, with a capacity of 240-300, is run predominantly as a commercial event space for weddings and other large scale events.

History

The Round Chapel and The Old School Rooms were built in the 1870s. The building reached a state of disrepair in 1991, when Hackney Historic Buildings Trust (HABT), English Heritage and Heart of Hackney decided to refurbish and separate the buildings ownership. HHBT bought the Round Chapel from the United Reformed Church for £1 (to save it from being demolished by the council). When transferring the ownership of the chapel it was agreed that HHBT would refurbish the site. The church moved into what is now The Old School Rooms. In 1995 the new minister understood the active role the church could play in providing community spaces and services. It was agreed that HHBT would also re-develop the space of TOSR.

Funding

TOSR partly rely on 5 anchor tenants who provide a stable income. These are the nursery, 4 small businesses and a co-working space (rented by the desk for a minimum of 6 months period). They also have 4 rooms for hire varying in size - these are available at discounted rates for members of the community as opposed to commercial clients. They also take commercial bookings for the whole site over

weekends. TOSR annual income at 2015 was roughly £225,000. The team estimated for the current year if they were to have a better capacity of staff and a sustainable level of income to run the building and its up-keep, they would need an annual turnover of at least £275,000. This means that, at 2016, TOSR is 45K short of what they need to really be financially sustainable. The budget earned through letting and hiring out spaces should allow in the future for the TORS to fully cover the expenses for the upkeep of the building and four part-time salaries.

Building Typology

The Round Chapel is a large purpose built chapel set back from a busy road and surrounded by a private garden and car park. TOSR are spread out over two floors, a basement and ground floor, with the management, anchor tenants, and co-working spaces all located in the basement. The flexible hire spaces are mostly located on the ground floor; these consist of the Lecture Hall, Kitchen, Church Room and Meeting Room.

Community

TOSR is an establishment committed to its surrounding community in Clapton. With 18 regular community groups booking the flexible spaces every week, it's obvious that this space provides not only an organised structure of programming but also it is ideal for non-commercial activities. Alongside these users, there are also four long-term projects: The monthly Community Meal, The weekly Urban Table with Community Drop in and the Village Green Nursery. Their running costs gets supported by the flexible tenants and has played a vital part for Clapton's community.

Address:

Clapton Park URC, Round Chapel Old School Rooms,
2 Powerscroft Road, E5 0PU, London

Office opening hours: Monday - Thursday 9.30am - 1.30pm

Round Chapel and the Old School Rooms

Program / User groups

18 community groups and an intense programme for the flexible spaces include:

- Yoga and pilates classes
- Art Bash, explore the world of art and design and create workshops for innovative and exciting happenings.
- Ballet North, offer dance classes to all ages.
- Acting Bugs classes, weekly drama sessions carefully devised so the parent/carer can join in alongside the child.
- Perform, a different type of drama school
- Hackney Bike Workshop, run by volunteers
- Sea Shanty Choir

4 long-term (anchor) projects

1. The Monthly Community Meal which has been running for 18 years by volunteers.
2. The weekly Urban Table and Community Drop In; it fulfilled the needs of the neighbourhood to provide a free meal every Sunday whilst offering emotional support to those that need it.
3. The Nursery 'Village Green', run by the nursery it provides a weekly free session in a relaxed setting where mothers and fathers can come with their children to meet other families and to look for advice.
4. The Community House, located a few streets away, was bought in 1995 as an investment. It acted as temporary home for 4 people who would also get involved in activities at TOSR as volunteers.

1.

Workspace funds Roundchapel.

2.

Large venue for bigger events which facilitates local needs.



3.

Well loved landmark buildings in local community

Long term continuity:

Community Meals

Nursery 'Village Green'

Community Drop-in

*

Round Chapel was sold in 1991.

STRUGGLES

Burden of sustaining the old building, which results in a £100K bill per year.

Current initiatives do not support each other.

Difficulty in getting funding without having a specific focus.



1. Round Chapel - ain Hall



2. Old School Rooms - Lecture Hall



4. OSR - Church Room



5. OSR - Meeting Room



7. OSR - Anchor Tenant (Nursery)

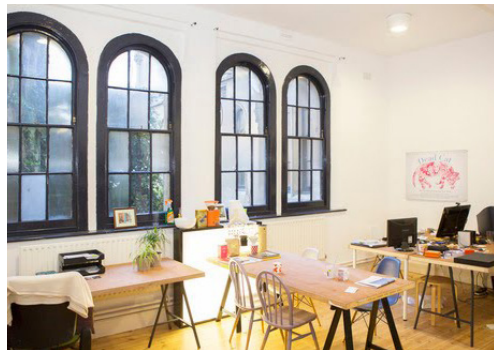

9. OSR - Anchor Tenant, Co-Working Space

Spatial layout

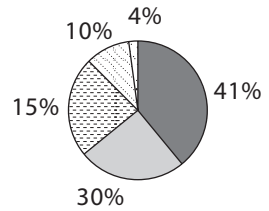
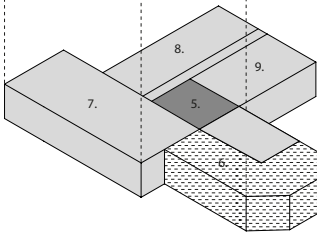
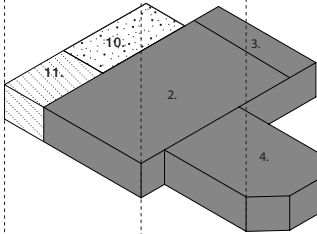

Flexible Space

- 1. Round Chapel Main Hall
- 2. Old School Rooms - Lecture Hall
- 3. Old School Rooms - Kitchen
- 4. Old School Rooms - Church Room



Staff Space

- 5. Meeting Room
- 6. TOSR - staff office



Anchor Tenants

- 7. TOSR Anchor Tenant - Nursey
- 8. TOSR Anchor Tenant - Small Businesses
- 9. TOSR Anchor Tenant - Co-working spaces



Green Spaces and Circulation

- 10. Small back garden used by nursery
- 11. Lift and staircases

GOVERNANCE & ECONOMY

TIMELINE
 built in 1870
 1991
 2005
 2016

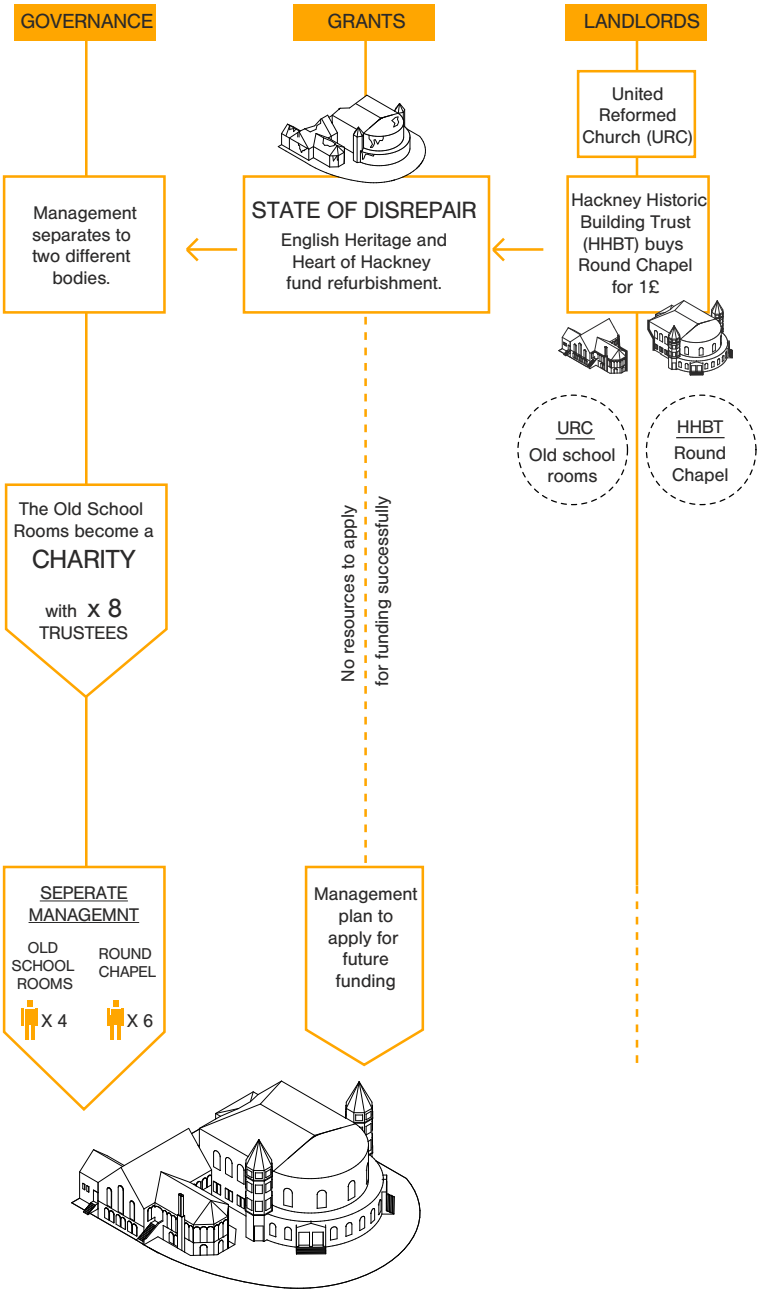

GOVERNANCE & ECONOMY

CURRENT INCOME STREAMS - OLD SCHOOL ROOMS



NOTE : The Round Chapel management and finances operate on private and commercial hire and are separate from the Old School Rooms.

CURRENT GOVERNANCE

	OLD SCHOOL ROOMS	ROUND CHAPEL
LANDLORD	UNITED REFORMED CHURCH	HACKNEY HISTORIC BUILDING TRUST
BOARD OF TRUSTEES		
MANAGEMENT AND STAFF		

Concluding

The OSR and the Round Chapel model provide an interesting precedence for heritage buildings transformed into community hubs.

Do's

+
The large availability and diversity of space allows TOSR's management to both use the rooms for local community groups, as well as to rent it out to other businesses.

+
Having other businesses and the co-working space allows the subsidy of other no/low-income community initiatives.

Don'ts

-
Current TOSR initiatives do not support each other, nor do TOSR and the Round Chapel collaborate which restricts a potential mutual benefit for both initiatives.

-
The lack of a specific focus amongst projects and their support has hindered the organisation in succeeding with funding applications.

-
The necessity of having a constant income stream means that the management is often forced to "give up" on a number of community spaces.

Impact

While the building's unique setting, architecture and history provide a desirable event space for the Round Chapel, it presents a challenge to TOSR as a community hall. The grade two listed building is expensive to repair, has restricted access and dated amenities that are too costly to change and maintain. The management of the OSR has been pushing for many years to provide a home to many local organisations in need of a space where to develop an ethos based on a strong social agenda.

Wanting to retain an acceptable amount of community space and at the same time aspiring to become completely self-sufficient seems to be a testing goal to achieve but, with the help of future funds and a strong support from the local community, TOSR should eventually be able to attain financial independence and the possibility to provide free of rent spaces for the local community.

OTHER SIMILAR EXAMPLES

MILDMAY COMMUNITY CENTRE:

It's a membership organisation and registered charity working with and for the community of Mildmay, a ward of Islington in north London. Membership is open to anyone who lives or works in the ward. We also manage the Mildmay Community Centre, an award-winning Passivhaus building available to hire for events, training and community projects. [mildmaycp.wordpress.com]

PECKHAM LIBERAL CLUB:

An old-school community members club in Peckham that also hosts concerts and other public performances. A bit of a hidden treasure, this 140-year old venue has real retro charm. Typically it's only open to members – joining costs £20 a year, and you'll somehow need to find two current members to endorse you. But you can also catch locally-organised gigs in the main hall. [www.facebook.com/peckhamlibclub/]



Bromley by Bow

A holistic place for health, skills, jobs and general neighbourhood well-being:
a home / a job / stable relationships

1.

Cross governance from within to retain a holistic mutual interest and ethos

2.

Created a framework which allows the local community to become its own support structure

3.

Doors always open and the design encourages users to feel comfortable hanging around

The Story

The Bromley by Bow Centre (BBBC) is an innovative community organisation in Tower Hamlets, East London, one of the most deprived boroughs in the UK. Each week the centre supports families, young people and adults to learn new skills, improve their health and wellbeing, find employment and develop their confidence to achieve their goals and transform their lives. At the core of the Centre's thinking is the belief in people and their capacity to achieve amazing things.

History

The idea for the centre launched when new Rev Andrew Mawson arrived to Bow United Reform Church to a congregation of just 12 people. To stop the premises from being closed, he decided to open up the church space for other community use and project ideas. To enable people to come forward, he did not ask for rent, but asked the users to run workshops that would benefit the local area. This approach helped establish the centre as a local asset and created a strong user group. A trust was initiated and a team of people came together to take ideas forward. The biggest change happened in 1997 after the death of a local resident, which, with the correct care, may have been avoided. Following this, the team decided to focus the centre around health in an attempt to prevent similar tragedies in the future. Successively, the team set up the first Healthy Living Centre (HLC) in the UK, through which they received funding from the NHS to grow. In addition to this, they negotiated the ownership for the derelict next-door park from the council, which in turn provided the ground for further growing and health initiatives.

Address:
St Leonard's St, Bromley by Bow, E3 3BT
Opening Hours:

Monday to Tuesday 8.30am - 8.30pm
Wednesday to Friday 8.30am - 8.30pm
Saturday & Sunday Closed

Funding and Management

The BBBC consists of a complex mixed economy with two businesses: the Bromley by Bow Centre Charity (BBBC) and the Bromley by Bow Health Partnership (BBBHP). The directors of the BBBC are also trustees for the BBBHP and vice versa. This means all those with decision-making power have a mutual interest and understanding of what each other's needs are. This setup ensures a continuous holistic approach and joint ethos. The Charity is owned by the local community via shares and is currently funded half publicly, half by corporate income and assets. The Health Partnership is funded by the NHS. These days the collective annual turnover exceeds £4.5 million; there are also over 150 staff and 55 different projects in over 26 different locations.

Building Typology

The building is designed so that it is as easy as possible for people to connect to the space. Just one architect worked on the centre throughout to ensure that each new building phase would integrate with the rest. Loitering is not disapproved of but encouraged for 'accidental meeting' opportunities for the users, all facilitated through an intricate design inspired by Oxbridge cloisters and courtyards. The spaces are intimate, solid and complex with brick and timber, that help the centre to emanate a holistic sense of well-being.

Community

The centre fosters a strong 'Yes-attitude' and encourages anyone to come forward with his or her own ideas. Developing ideas together and community ownership of the space play a key role in giving people authority over the space.



1. Pic-nic in front of Community Centre



2. Community Centre and Health Centre



3. Courtyard 1



6. The Barn



Courtyard 2



Stained Glass Studio

Spatial layout

Locations

1. Community Centre
2. Arts and Crafts
3. Hall
4. Church
5. Health Centre
6. Barn



Ancillary Spaces

8. Offices

13. Offices

14. IT Classroom

17. Learning Team Office

19. Operations Office

28. Housing Office / IT Cafe /
Jobsearch

31. Office Area

33. Nursery

35. Therapy Room

40. Green Dreams / Beyond the Barn



Anchor Spaces

18. Learning Embassadors

22. Sure Start

23. Working Wonderins



Workshops

2. Arts and Crafts

16. Stained Glass Workshop

25. Stonecarving

26. Pottery



Flexible Spaces

7. Hall

11. Conference Room

12. Presentation Room

15. Project Room

20. General Activity Space

21. Bookable Meeting Room

24. Staff Kitchen

27. Community Day Centre

29. Kitchen

30. Cafe Public Area

32. Lecture / Classroom

34. Consulting Rooms

37. Consulting Rooms

36. Reception / Waiting Area

39. Classroom

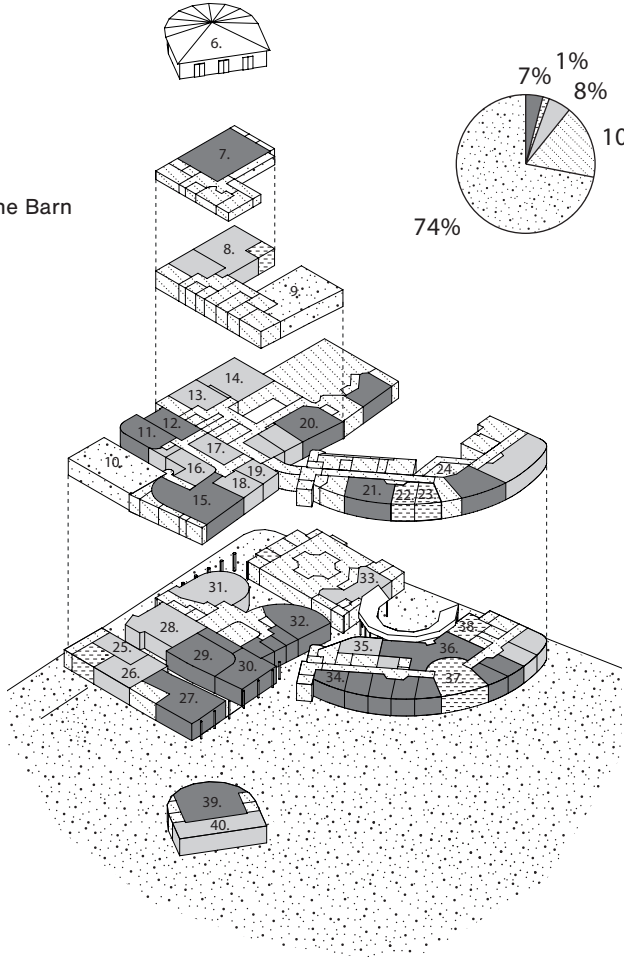
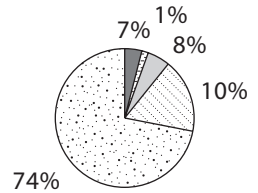
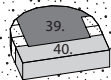
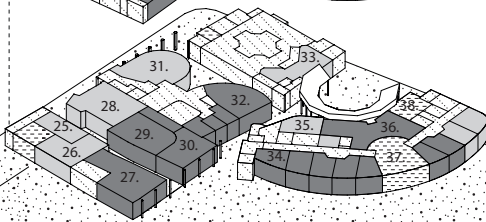
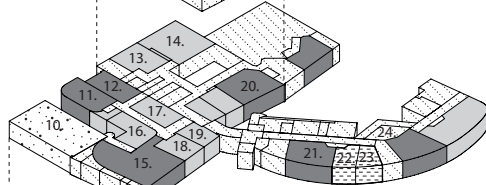
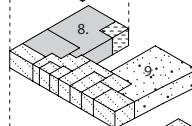
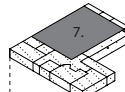
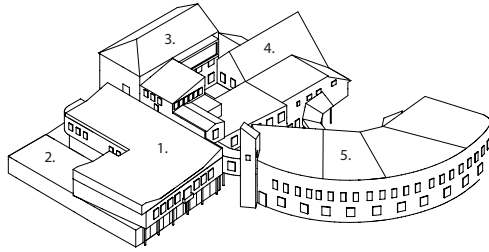

General Program

The program is defined by the tenants who each offer community faced facilities that can be related back to health and wellbeing. Current tenants include:

- GP surgery - with flexible reception space that acts as communal area and gallery
- Cafe - Affordable healthy food making it accessible to local people
- Wellbeing - health, housing, education and social services
- Public gardens - created and maintained by volunteers
- Church - worship, nursery, theatre/performance
- Craft - pottery, stone carving, stained glass windowing
- Flexible space - for education, seminars, meetings, projects, workshops and general hire

1.

Recognised how they could provide a more holistic well-being approach

2.

Created a framework which allows the local community to become its own support structure

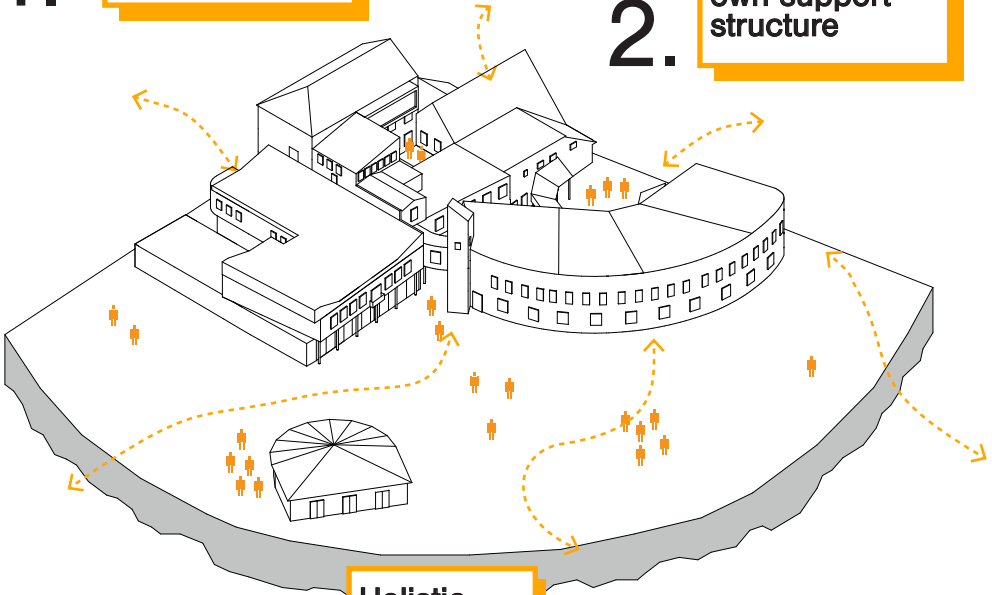

3.

Holistic wellbeing approach

Housing support

Job support

Formal/
informal
relationship
support

+ CENTRE HAS GROWN ORGANICALLY OVER TIME SUCCESSFULLY LINKING HEALTH SERVICES WITH OTHER COMMUNITY PROVISIONS

GOVERNANCE & ECONOMY

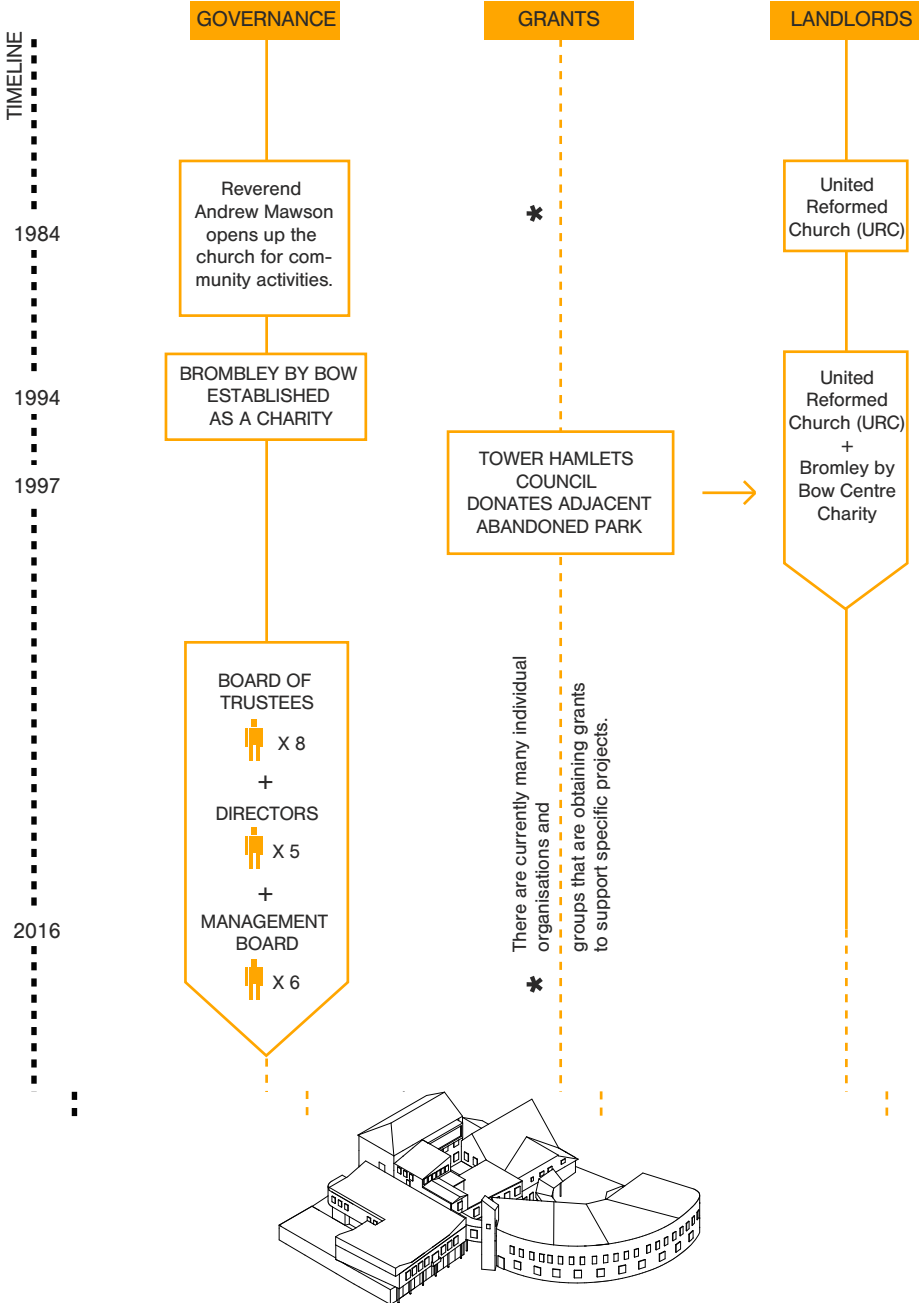

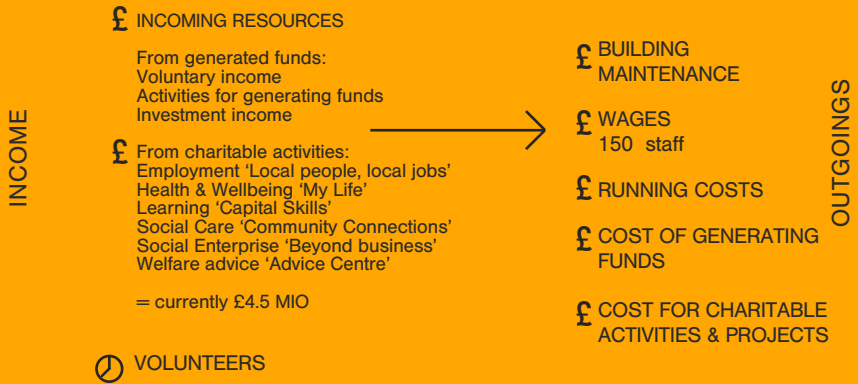

GOVERNANCE & ECONOMY

CURRENT INCOME STREAMS



CURRENT GOVERNANCE

LANDLORD	SHARED OWNERSHIP : UNITED REFORMED CHURCH & BROMLEY BY BOW CENTRE CHARITY
BOARD OF TRUSTEES	
VOLUNTEER BOARD OF DIRECTORS	 Lord Andrew Mawson OBE Zenith Rahman Ajit Lalvani Chris Elliott Simon Bevan
SENIOR MANAGEMENT	 Rob Trimble CEO Julia Davies Assistant Chief Executive Tony Bonnar Director of Finance and Operations Dan Hopewell Director of Knowledge and Innovation Zoe Portlock Director of Services Hejal Uddin Director of Regeneration and Engagement

Concluding

Do's

+
The centre has grown organically over a long period of time, successfully linking health services with other community provisions.

+
Initially, space was offered for a return of in-kind workshops or volunteering, rather than rent. This instilled trust and set up a strong network of user groups to grow the centre.

+
Loitering is seen as a positive asset. The open courtyards and lack of barriers draw people in naturally.

+
Incremental building allowed for spaces to be built when they were needed, rather than being imposed from the start.

+
Consider within the current context. The Bromley by Bow model would be very difficult to repeat directly nowadays due to the extremely favourable conditions in which it was established back in the 60's. The level of trust that was given to rev. Mawson and his community was incredibly high and it would be very hard to picture a similar situation nowadays.

Impact

The Bromley By Bow Centre exemplifies the current political shift from public service to public-private initiative. Rather than solely becoming a service provider, the BBBC continues to act as a platform and framework for people to invest themselves into. This allows the BBBC to progressively evolve driven by the strengths, skills and energy of the community. The organic process through which the centre has evolved was pivotal for this, allowing an evolution from within that has allowed a rich, multifunctional space to develop (not imposed from the start). Alongside this, the strong business drive made it possible for smaller no/small profit projects to flourish.

OTHER SIMILAR EXAMPLES

TOYNEBEE HALL: work on the frontline in the struggle against poverty. Based in the East End of London we give some of the UK's most deprived communities a voice, providing access to free advice and support and working together to tackle social injustice. Our youth and older people's projects, advice services and financial inclusion work are all geared towards supporting those who live in some of the most deprived conditions in the UK.

[www.toynbeehall.org.uk]

ST. KATHERINE'S PRECINCT: St Katharine's Precinct is a first step in the next phase of The Foundation's mission of worship, hospitality and service in the East End – building connections with and between communities through reflection, conversation, art, community projects and food.

[precinct.rfsk.org]



Hub 67

A small-scale and flexible top-down community space in Hackney Wick.

1.

Initiated and supported by the LLDC to meet the demand for a new community centre.

2.

The space is very flexible and can host from a small gathering to big events.

3.

About to join up with local theatre (The Yard) to increase its outreach and occupancy.

The History

Hub 67 was brought to life after a group of Hackney Wick's local residents expressed the dire need for a new community space for the young and old of the area. It finally launched in December 2014 as a space and project run by the East End Community Foundation, with a Steering Group of local residents that had formed during the preceding Wick Festival.

The Space

The Hub 67 space was always intended to be a longer-term, but temporary project. In this ethos, the building materials were recycled from cabins used in the London 2012 Olympic and Paralympic Games. The building's facade and chandelier in the main space are designed and built with the local community, with the aim to give the community a sense of ownership and to embed the building into the new area.

Funding

The project was funded as a donation by the London Legacy Development Corporation (LLDC). This included the site, the building, project and management costs for year one and free WIFI for the entirety of the project span. Additionally, there was funding from the Wick Award to cover further project costs. The available funds have now run out, and the project cannot continue as it currently stands as they have not yet found a way to finance themselves.

Community

In response to the local Census, the centre was first intended for a young audience, but unfortunately there was not much interest expressed after the initial school outreach program.

Consequently the centre has taken a more all-inclusive, all-ages approach. To make this happen, the centre's manager rigorously advertised the project with local housing associations, children's centre and other local community events. Through this Hub67 has seen regular bookings from groups like the After School Club, The Hackney Wick Women's Institute and the Hackney Tea Club. Adjacent to the site, the LLDC had also initiated a skate park. According to the manager there could have been great potential for the two programmes to overlap programmatically, but this was not possible due to restricted budget as well as health and safety management.

Moving Forward - The Yard Theatre

With the funding that was previously available coming to a close, the centre's management is now being taken over by the nearby Yard Theatre and is due to move to a new site in 2018. The Yard has won multiple awards and is unique in supporting unknown, emerging artists. Generally partnering with a different project with regular footfall will be beneficial for both parties involved.

In addition to this, all the shows that are created in The Yard are rehearsed in local community centres in return for free workshops. Hence they have already got a well-established local network of potential users. The Yard also feature a bar and restaurant, which will also bring increased footfall and attention to the Hub community space. Additionally, their new site location adjacent to a secondary school is likely to make it easier to target young people as the main user group of the space.

Address:

67 Rothbury Road

Hackney Wick, E9 5HA

Opening Hours:

Office hours: M-F 10am – 5pm

Program / User groups

Youth

Skyway after school club and homework hub
ABC Spanish program
Immediate Theatre summer workshops

In September, Hub 67 launched a clothes exchange for children's clothing, so that items that are no longer the right size or unwanted can be swapped for other clothes or toys.

General

5 day/week access to computers and internet
Omega Yoga and Our Parks Yoga (have now moved to the Olympic Park for the summer)
Hackney Wick Women's Group

The regular Work Hub allowed for Jobseeker Drop-In, CV advice, job searching and mock job interviews and supported several locals people.

Further one-off events include: 'Make your own tea bag & tea tasting', Morning coffee and free health checks, IT-skills & E-learning, Hackney Wick Festival, Streetdance & Breakdance for youths, Over 50's steel drum lessons. Further family learning activities include Toddler Tempo and Pumpkin Party, as part of Hackney Learning Trust's Family Learning Festival.

Hub is started and funded by LLDC for 1 year.

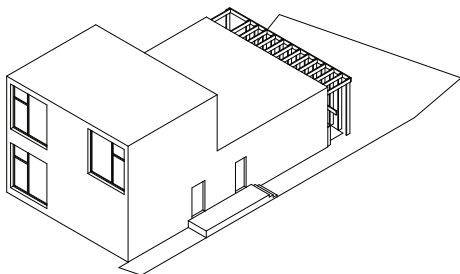

1. Attachment to LLDC and EECO reduces ability to apply for small funding pots leading to lack of programming.

2. Lack of anchor tenants stops regular footfall and use of the hub.

3. Mobile nature allows for opportunity to link up with other projects.



1. Hub67 will be managed by The Yard Theatre, which will provide a cultural driver with an existing user group and allow for more flexible management.

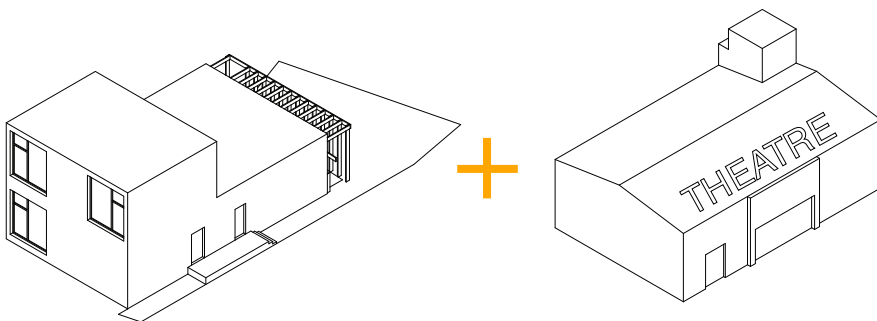



1. Hub Entrance



2. The Reception Area & 3. Lobby Area



4. Main Event Space, Meeting



4. Soft Play Area for WickMas



Sarah Gardening



Exterior of the Hub

Spatial layout

Total Area: 135 sqm
Flexible Area: 50 + 45 sqm
Staff Rooms: 10s qm
Other Rooms: 30 sqm

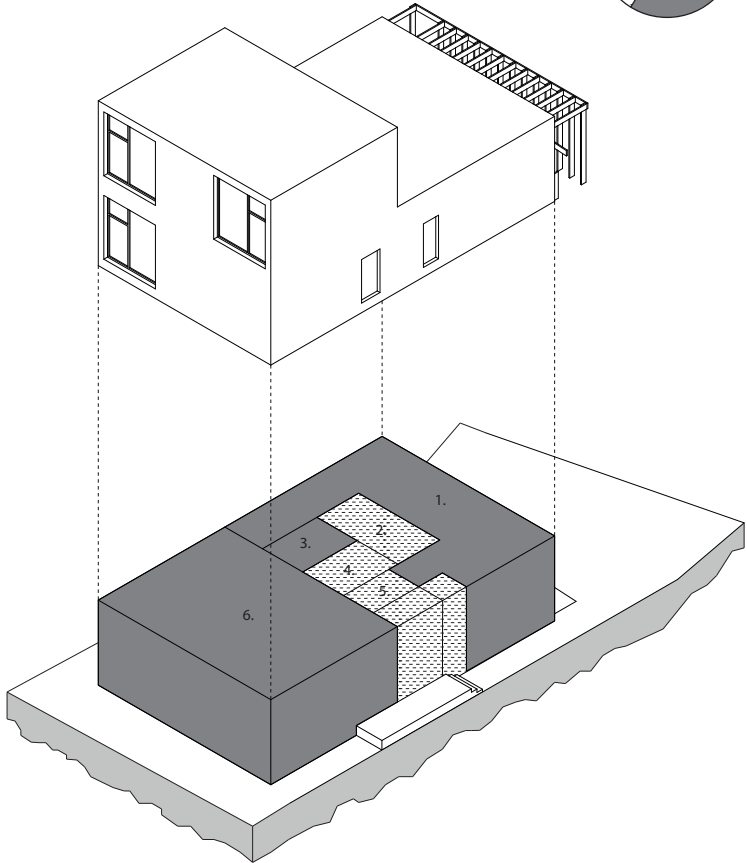
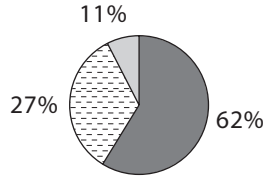

Flexible Space
1. Lobby Area
3. Meeting Room
6. Main Space



Other
2. Reception and
4. Staff Office
5. Staff kitchen & WCs

GOVERNANCE & ECONOMY

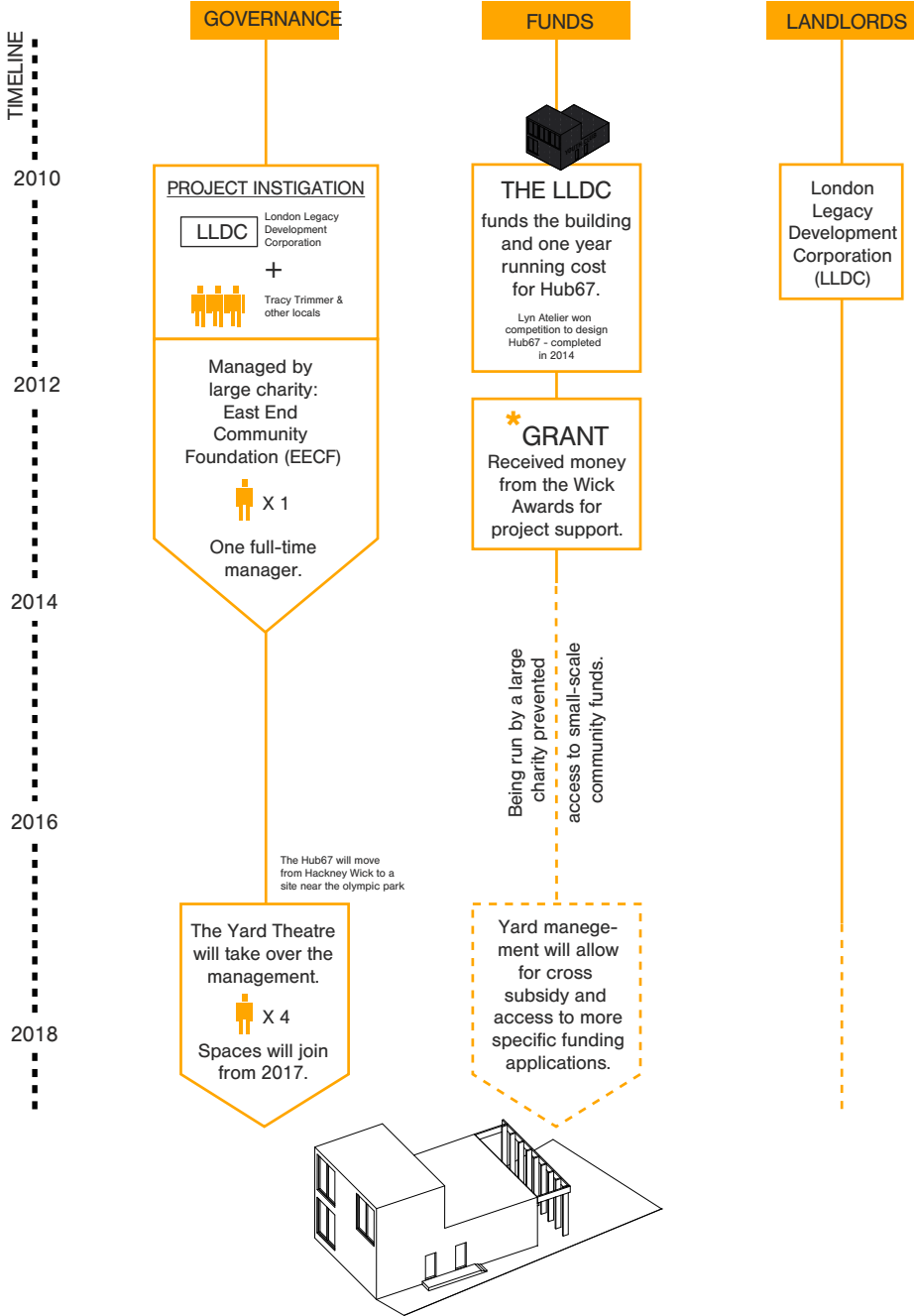

GOVERNANCE & ECONOMY

CURRENT INCOME STREAMS

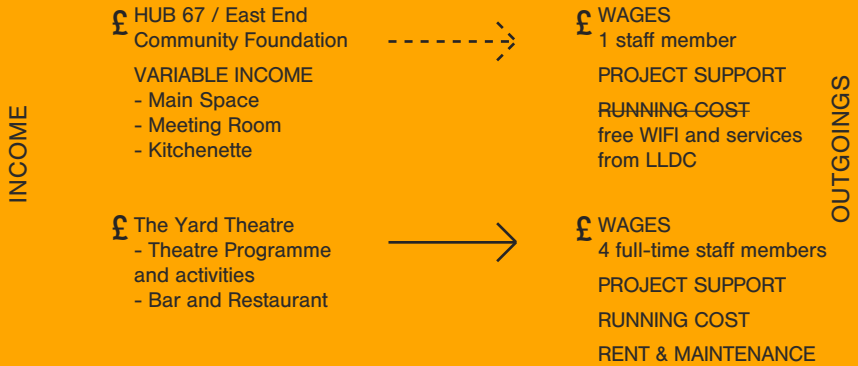

CURRENT GOVERNANCE

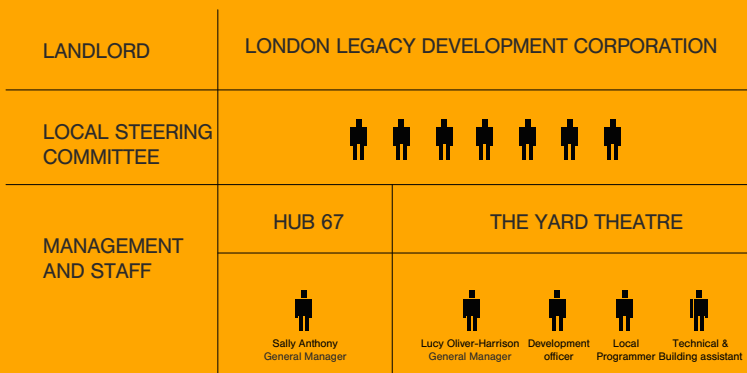

Concluding

Do's

+

Offering children's parties for under £100 was a great way to bring attention to the centre through word of mouth in the first place.

+

Word of mouth 'advertisement' amongst families can quickly instil a sense of self-discovery and ownership.

Dont's

-

Not having a specific focus made it difficult to apply for small-scale funds to support the project.

-

Being run by a large charity body restricted their eligibility to small-scale funds that would have been necessary to sustain the project. Consider

the organisational set-up right from the start.

-

If a space is initiated, managed and run by a large 'foreign' body, as it was the case with Hub67, it can counteract a growing sense of ownership amongst the community members. Consider this when setting up a space.

-

It takes a long time to build up trust in the local community. Setting up a project with a short life span has its limitations.

-

Don't just rely on a single person to manage the space. It is important to set up a team of people with different expertise for general management, outreach and funding applications.

Impact

For the fact that the Hub 67 has only been open to the public for less than two years, they have managed to attract a successful range of user groups and projects to the space. However, these have been more sporadic and projects and volunteers have often come from further away rather than from the local community. This meant that until now, it was not possible to create a strong, local user-base that enabled local people to meet and to generate projects together. Even though the Hub pitched to be resident-led and it had a local steering group of eight members, the lack of focus and initial programme or project did not provide enough structure for the community to regularly come together and make use of the space. Joining forces with a well-established and well-connected theatre with an anchor tenant (the bar/restaurant) holds a promising future for the Hub 67 project.

OTHER SIMILAR EXAMPLES

IMPACT HUB: Impact Hubs provide the spaces, resources, connections, knowledge, talent, markets, and investment that turn intention into impact. In every community we work with, wherever we are, we commit to awakening the imaginations, livelihoods, and economies of our surroundings--enabling collaborative action towards sustainable impact. Spanning the physical and virtual environment of entrepreneurship, Impact Hubs are a driving force within the global movement creating a better world.
[www.impacthub.net]

OCTOPUS COMMUNITY: Octopus is driven by the collective desire to develop community centres as 'hubs' in the community, where multiple grass-roots services and wide-ranging facilities can be accessed and influenced by the unique needs of diverse communities and local neighbourhoods.
[www.octopuscommunities.org.uk]



The Green Man

The Green Man is a building for everyone and it includes a housing reception and office space, housing association, a café, facilities for local training, a market yard and other spaces for public hire.

1.

Green Man acts as the community centre to the Phoenix, the UK's first tenant run Community Gateway Housing Associations.

2.

The concept of co-regulation, and in particular, tenant scrutiny, lies at the heart of maintaining the consumer standards.

3.

The building is entirely self-sufficient and no longer reliant on public funding. It also provides affordable work-space for rent.

The Story

The Green Man was designed to establish an HQ for the Phoenix Community Housing Association whilst creating a centralised meeting place for the 6,000 local homes that it looks after. Taking its name from the pub that was formerly on the site, it is located in Beckenaham and acts as a community centre for all of the surrounding residents.

History

The Phoenix Community Housing Association is a resident-led housing association, one of the first in the country, set up in 2007 when 6,000 homes were transferred over from Lewisham Council to the PCHA. A competition was developed to design The Green Man and in 2011 Black Architecture won the bid and the building was opened in 2013.

Funding and Governance

The Green Man is entirely self-sufficient and no longer reliant on public funding. The financing of the GM is not straight forward. PCHA acquired the site through a barter deal, swooping for a derelict block the association had elsewhere. The land in effect was bought for zero. PCHA financed the construction costs through existing finances. When Phoenix was set up, they received a grant from the DCLG for the decent homes works to the 6,000 homes. Currently there are around 150 PCHA staff all located within the top floor of the Green Man. They run the housing association and also the Green Man itself. Flexible spaces are rented out to commercial clients in order to fund free and cheaper activities for community groups. There are a vast variety and quantity of user groups that use the building on a daily basis.

The Phoenix CHA Board is made up of:

- 6 residents inc. Chair and 2 Vic Chair
- 2 Lewisham Council Representatives
- 4 independent member

Building Typology

The Green Man is an impressive stand-alone building in Beckenham whose open door policy is immediately recognisable from the street. The ground floor is dedicated to providing flexible spaces for the residents, whilst the upstairs houses 150 Phoenix CHA staff.

The cafe, located adjacent to the entrance, is a thriving hub of activity run in partnership with Lewisham Council who also run a Training Kitchen on the ground floor. The ground floor has a large open plan flexible space called the Market Square or Hub where people can freely congregate. With open sessions happening throughout the day that anyone can join.

Community

As The Green Man building was being designed, the PCHA attempted to create partnerships with companies that would become permanent tenants of the building. Lewisham Council run a Training Kitchen with Chartwells, which offers chef and management training to local people, who can then go on to work in the cafe, run by the same management team. Lewisham Plus Credit Union is a co-operative “not for profit” organisation and a permanent tenant at The Green Man.

Address:

The Green Man, 355 Bromley Road, London, SE6 2RP

Opening times:

Cafe: Mon - Fri: 9am - 4pm

Program / User groups

General

Lewisham Tai Chi offers a beginners class for those looking to learn and practice tai chi in a relaxed and friendly environment.

Conversation Club is friendly English conversation club.

Phoenix Job Club offers help with creating or updating CV, support to complete application forms, internet access for live job searches, coaching and advice.

Fab Friday offers meeting point and activities for over 55 each week including bingo and talks on interesting subjects.

LGBT drop-in is a monthly get together, an open forum where issues can be discussed, information obtained and social networks developed.

BEAM stands for Beautiful Empowered and Me, it's a weekly inspirational activity and discussion based session for girls aged 10-14.

Monday markets where local traders and makers sell a wide range of wares. Stalls include gifts, jewellery, clothing, food, health products and more.

Jelly Babies Baby Massage classes to help learn relaxation tips to calm babies and meet fellow new parents.

Aquilla Fitness, a beginner and intermediate general fitness and exercise class.

Greenwich & Lewisham Young People's Theatre (GLYPT) offers drama and performance activities for young people aged 8 - 11

Advice & information services

Free energy advice

Staff from Phoenix Community Housing are on hand to give free advice on how to reduce energy bills and point you in the direction of other energy-related benefits.

Citizen Advice Bureau

Free confidential and impartial generalist advice provided by trained advisors.

Lewisham Reach

Free and confidential advice and support by skilled advisors on housing, rent arrears, benefits, education and employment.

Councillor Surgeries offers pop in consultation with a local Councillor

1.

The services provided by the Green Man centre benefit both housing association residents and wider community

2.

Working closely with Lewisham council allows the centre to provide direct support for the residents in need

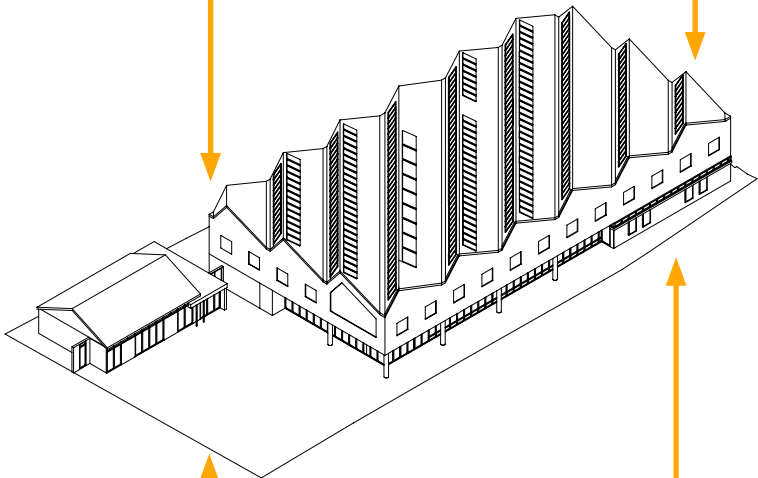

3.

Its location provides strong connections with the local community and wide offer of spaces for rent at affordable prices

4.

The flexible desing of the building allows the management to divide or combine spaces to accomodate comfortably different groups



The Green Man Centre



Main Entrance



Green Man Community Cafe



Flexible Workspace

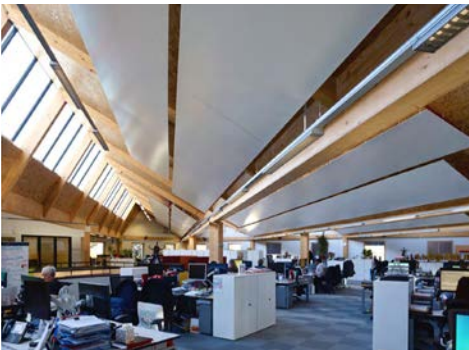

Staff Office



Co-working space

Spatial layout

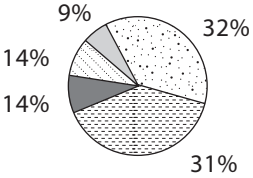

Total Area: 5950sqm
 Flexible Area: 870sqm
 Anchor Tenant: 520sqm
 Staff Rooms: 1830sqm
 Outdoor Area: 1890sqm

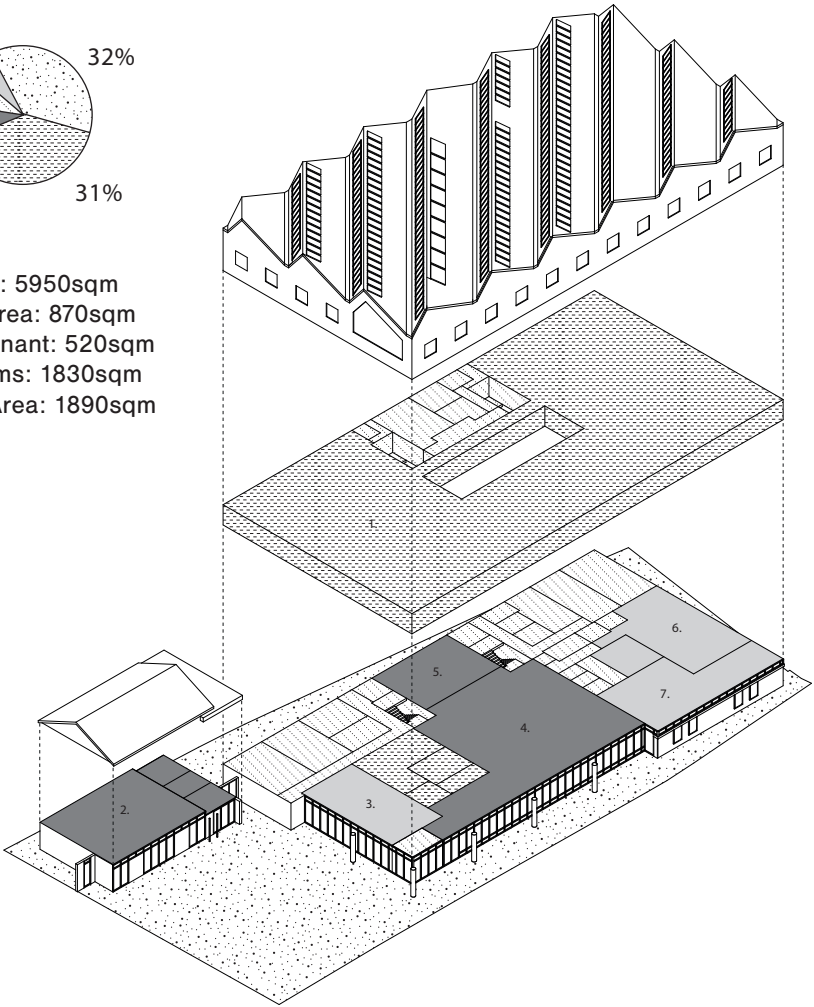

Anchor Tenant

- 3. Cafe in partnership with Lewisham Council
- 6. Training Kitchen and Classroom
- 7. Lewisham Plus Credit Union



Flexible Space

- 2. The Barn
- 4. The Hub Co-working
- 5. Meeting / Training / Board Room



Other

- 1. Flexible Office Space for PCHA



Staff Offices
Circulation

GOVERNANCE & ECONOMY

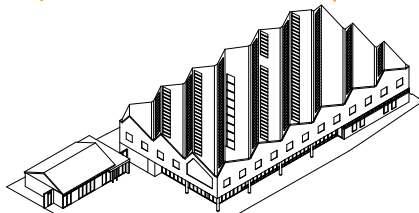
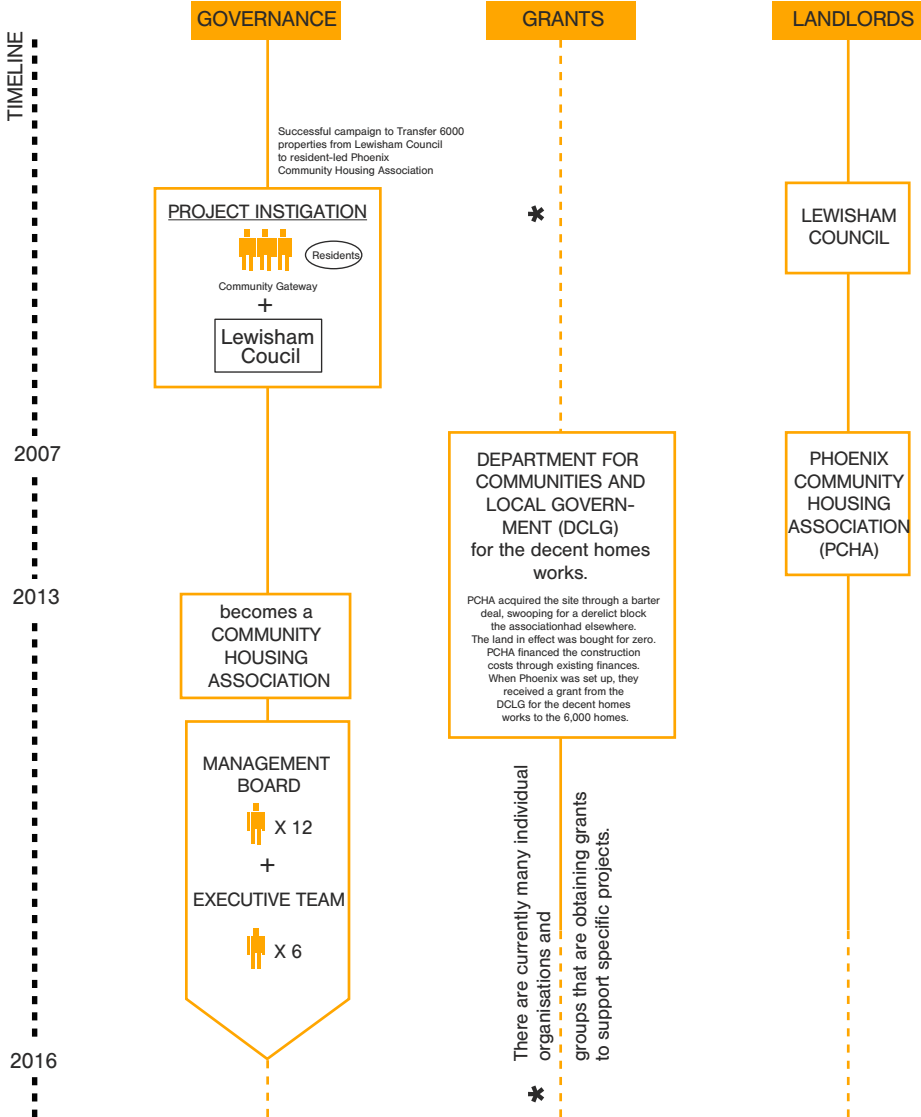

GOVERNANCE & ECONOMY

CURRENT INCOME STREAMS



CURRENT GOVERNANCE

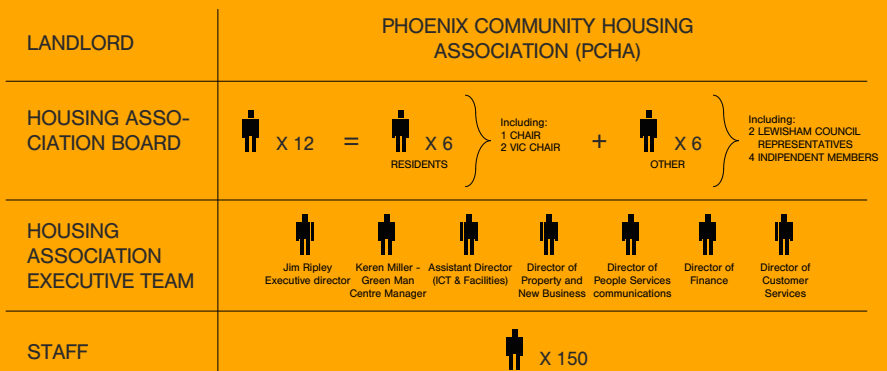

Concluding

The Green Man present itself as a positive example of a partnership between community housing association, local residents and council. With the strong support of Lewisham, the centre was able to establish itself in the community and offer a wide local program.

Do's

+
The Green Man serves 6,000 homes in the surrounding area. As a resident-led housing association it is intrinsically resident involved, yet the Green Man supports many other projects for the wider local community.

+
Involving these permanent tenants at an early stage meant that there was still flexibility in the design of their spaces which they benefitted from.

+
It is essential to do a workshop before the detail design of a project like this commences to get a hierarchy of priorities.

+
An important action is to incorporate flexibility in the design, layout and operation of the building. Residents and local community requirements change and flexibility needs to be built in to allow services and delivery to evolve and shape to meet ever changing demands and needs.

+
Don't underestimate the value of good architecture. A great building can be promote positivity and inspire occupants and visitors, and in the case of the Green Man, help improve social, economic and environmental conditions in an area.

Impact

The Green Man locally focused and independent governance system, together with a 150 strong staff working closely in the same central building, provides the necessary stability to allow the residents and the local users to take ownership of the centre and truly benefit from the programme of activities and events. Through a wide range of spaces, from the main community space, the Hub, where most local groups meet, and the mainly commercial space, the Barn, available for hire at affordable rates for the residents, these spaces provide necessary autonomy and allow a flexibility for the PCHA to respond to evolving needs and opportunities.

The durable connection with Lewisham council is also an other main key element behind the success of the centre, giving the possibility to the residents to identify the GM as a place where to find professional advice and a direct link with local institutions.

OTHER SIMILAR EXAMPLES

PEABODY BEDZED PAVILION:

The Pavilion is managed by The New Possibility Committee, in partnership with the Peabody Trust and the London Borough of Sutton. It is a part of the first large-scale eco-community in the UK. Completed in 2002, Peabody led the BedZED (Beddington Zero Energy Development) in partnership with Bill Dunster Architects and environmental consultants BioRegional.

[www.bioregional.com/bedzed]

THE REDMOND COMMUNITY CENTRE, WOODBERRY DOWN:

Manor House Development Trust manages the Redmond Community Centre, where we run a range of different services for the local community. Manor House Development Trust is a charitable social enterprise. We deliver and help other organisations to deliver community services which are value for money and create lasting benefits. This approach allows the community to lead and determine its own future.

[www.mhdt.org.uk/the-redmond-community-centre]

Conclusion

In relation to evaluation principles:

1. Social ecosystem
2. Specific function or cultural driver
3. Responsive governance
4. Being local
5. Anchor tenants
6. Creative funding
7. Time, ownership and trust
8. Desired Spatial Qualities

Conclusion

This report presents comprehensive evidence that should inform future projects responding to the on-going need for civic spaces. Based on the research presented in this document, we make the following conclusions and recommendations. These eight principles summarise the most relevant learning outcomes:

1. Social Eco-systems

(Best examples - Stour Space / BBBC)

The most exciting spaces curate an eco-system within them and become part of a wider eco-system of the local area.

If we take Stour Space as an example, each function has a mutual benefit and reliance on another. The gallery/shop provides free exhibition space and an outlet for the tenants (artists) but also takes a commission on sales. The gallery / event space in turn brings footfall to the Café and the rent on the Café allows for cheap artist studio space to be provided. As a whole, Stour Space becomes its own cultural destination. This layering of functions creates exciting multi-faceted and resilient spaces which is evident in how well used the space is, both as daytime and night time economies - not just when the bar opens.

2. Specific function or cultural driver

(Best examples - Chats Palace / BBBC / Stour Space)

A specific function or activity for a space is valuable to instigate a group of people to come together and provides the necessary platform for diverse initiatives that can lead to the next stages of

a project. In the case of Stour Space all the activities are centred around the arts. This simplifies management, access to funds and an overall idea of what the space is about. At the same time the specificity of the space refrains other community groups with other interests to join. In Chats Palace the focus is still cultural, yet this focus is used as a point of access for broader initiatives of all community members. In the case of Hub67 the lack of a specific programme attracting initial users resulted in the centre not being able to organically establish itself. Particularly for short-term initiatives a specific use can be a good catalyst to start off the project. In regard to long-term initiatives, the BBBC is a good example of a centre that started off as an art and skill-share project, which then translated into a health and well-being centre. It is important for management to retain a certain level of flexibility of use in order to accommodate evolving community needs.

3. Responsive Governance

(Best examples - Stour Space / BBBC / Green Man)

Governance is crucial - the most successful examples are those that are self-governed from within, creating space for user autonomy and allow a flexibility to respond to evolving needs and opportunities (Stour Space / BBBC / Green Man). The last thing governance should do is limit potential (Hub 67 / Round Chapel). Though governance structure may often become complicated, when worked out carefully it can be the key to success. If we compare BBBC and Round Chapel, Round Chapel exists as two separate entities, the Round Chapel event space with its own large income, and the Old School Rooms, which struggle to survive financially due to the need to finance its socially centred agenda.

If these were considered as one whole, then the whole centre may be able to rise to new heights due to financial stability provided by the more commercially based space hire system characterising the main auditorium, and the Old School Room could provide a mutual benefit back to the Round Chapel. BBBC recognised this and hence developed a governance structure where each party is mutually invested in other initiatives meaning the centre is always moving forward as one unit.

4. Being local

(Best example – Stour Space & BBBC)

It is a key aim of a community space to provide for and make use of its local area and people so the project can become truly embedded in its locality and serve a local need. Stour Space made use of local scrap building materials from other businesses and local volunteers which created a connection that was later useful for some of the art projects and created awareness amongst local businesses about the happening of the project. Furthermore, using local suppliers for services or produce (for the Café) can help to lay out the project's intentions and ethos clearly and through this get more local people involved. If relationships with other local key stakeholders are formed from the start and throughout, this can also play an important role in facilitating projects or initiatives to drive the centre forward.

5. Anchor tenants

(Best example – Stour Space / Chats Palace/ Green Man)

Across all the case studies it was evident that the presence of anchor tenants created benefits for the overall project. Anchor

tenants create a steady stream of footfall to a space and help to subsidise other low/ no profit initiatives for community benefit. With its theatre, photo rooms and Café Chats Palace is a successful example of anchor tenants supporting smaller community initiatives. Green Man is also a successful example for this. Hub67 has struggled to sustain itself both financially and in footfall, but joining forces with the Yard Theatre is a clever move to overcome this and we believe that both parties will benefit from each other's networks. Cafés and food offers are an easy way to generate footfall and profit for a project – across the board all most successful case studies have one of these incorporated.

6. Creative Funding (Best example - Stour Space / BBBC)

As state funding is reduced, creative funding has been the only means of survival for many community spaces - there is a general move towards self-sustainability. The most common tactic is to cross-subsidise with profit making functions such as space rental or a Café/ bar/restaurant (BBBC / Stour Space).

Other spaces such as BBBC go beyond this and look at alternative government funding as well as cross-subsidising. By taking up the responsibility of the NHS they claim eligibility to part of their funding, which also allows them to provide additional community programmes. The example of BBBC is successful as they are able to also provide a better service. This however would not be recommended if it would reduce the quality of the service.

7. Time, ownership and trust (Best example - BBBC)

Time is a means of developing trust and ownership with the local area and attracting a user group. As one would expect, spaces that develop organically over time usually have the most committed user groups and resilient coping strategies. In the case of BBBC, its users have driven its development and project progression over a long period of time, which has developed deep levels of trust and ownership. Contrary to this, in Hub 67 there was a limited amount of time and a programme that was partially imposed from external forces. This combination hindered the project from flourishing. However, in our current context where for example limited funds require more immediate results the luxury of time may be limited. Having a specific function or cultural driver is often paramount for new spaces in the current context. These give a specific interest group, which can be the base for a more organic local user group to form.

8. Desired Spatial Qualities (Best example – Green Man / Stour Space / BBBC)

Both types of spaces, old historic and newly designed, offer their pros and cons to the contemporary civic space. An old building fabric often adds character to a space and helps to attract external bookings, as evident in Chats Palace, The Old School Rooms and Stour Space. However, their often rigid structural layout can be hindering to a more contemporary, flexible set of activities and rentals, like it is the case in the lower ground floor of The Old School Rooms. Also in Stour Space, the services had to cleverly adapt to the existing layout of the building. Through an astute re-

furbishment of the old warehouse, which involved the creation of a series small studio spaces gravitating around a central gallery and communal room, the building managed to maintain a good balance between private and public.

Contrary to this, the highly flexible indoor and outdoor spaces of the Green Man allow for a successful operation of each building and a cohesive management of the community based activities. The recently completed design of the Green Man follows an open plan strategy in which spaces can be easily shifted and transformed, in order to meet ever changing demands and needs of the programmes and activities taking place inside the centre.

Bromley by Bow is a particular example, as the centre has spatially grown with the programme and some spaces are project and activity specific, whereas others are more flexible. However, it is important to note, that the BBBC is a unique type of centre and highly specific to its mental health use. Summarising this, the spatial requirements for a contemporary civic space must be highly flexible. At the same time, their acoustic and visual relations should allow for privacy and larger gathering when both in smaller or larger configurations.

Do's

1. Production vs. consumption

It is highly important for civic spaces to offer services and activities without financial ties to ensure an all-inclusive approach for all community members. Cafés or shops may form a secondary point of attraction, however free services or the generation of shared knowledge should be in the foreground. This also should be tailored to the local community's needs and/ or be clear with the project type.

2. Involve your local community

Involving your local community creates a sense of ownership and trust, and helps the project to become embedded and to ensure its longevity. Be aware that community can take on different meanings to different projects. It is important to be clear what exactly community means to your project and how you aim to involve it: initial project consultation, volunteers and builders (Stour Space), projects champions, staff (BBBC) and performers (The Yard).

3. Start with a project champion

A project champion carries a highly important role so new members have a specific person and face to turn to for new ideas, problems and all. Ideally the project champion has local connections or is able to build these up quickly for example through linking with other local initiatives. Additionally, this person should have a combination of the following skills and experience: leadership skills, good social skills, commitment to the project's principles and resilience against problems and obstacles. This role should be in place before the commencement of a project and could be carried out by a manager, artist, local stakeholder,

design or funder depending on the project type.

4. Start with a clear project type and agenda

Across all the projects researched, it was evident that having a clear agenda or project type (cultural, health, work or other) is beneficial for the project's success. A clear message from the start prevents confusion and draws in an initial audience often also with an agenda. As seen with most projects, after time this can shift (relevance of points 5 and 6).

5. Be clear about your audience

This point ties strongly with having a clear project type and agenda. Be clear about what the local audience is – do not rely on census data but make direct contact with other local initiatives or local community stakeholders. This will impact budgets, marketing/ advertising and project direction. This of course will form a strong indicator of the project's success.

6. Be flexible and adaptive

Even though it is good to start with a clear agenda or project type, it is important to be open to new ideas. As the project evolves, local demographic or trends change. Again, being flexible with this will instill a sense of trust and ownership with the local community and the people who propose a change. BBBC has been particularly successful examples of this.

7. Be fair to your volunteers

All projects researched would have not been possible without having made use of volunteers at one stage or another. They hence form an invaluable resource to each project and are vital in

forging new relationships between community members, sharing skills, ideas and possibly generating new project directions. Asking people to work for free can however be problematic.

8. Have an online presence

This is a must in order to raise awareness of your project, attract future audiences, to raise funds or to generate new ideas and interests. A website can also help to connect with other local or global projects and provide a good project history and archive (particularly useful for funders or other people who want to set up similar projects).

Don'ts

1. Do not underestimate the importance of preparation time

All researched projects that are successful now have undergone a slow start-up period for project initiation. We recommend an extensive preparation period with the project champion (and possible local stakeholders) about exact project type, target audience, fundraising, project duration, business model and risk assessment. If you know what your ideal final outcome will be, it is useful to reverse the order of the project to see if all open questions are covered.

2. Do not start without a site

It is very difficult or unlikely to create a successful project without a project space. The space forms an important reference and anchor point to the project and should be carefully considered and integrated right from the start. The site is often a key factor that makes a project unique (all projects), and should be celebrated as a stimulus and inspiration for the project (BBBC, Stour

Space and Chats Palace).

3. Do not limit your brief

Even though a clear brief to start with is mostly beneficial, it should be subject to possible adaptation and not dictate a project. This can create a more ambitious and locally appropriate project in the long-term.

4. Do not rely on a project 'formula'

Each project is unique because of its space and its (local) people involved. We do not think that it is possible to exactly replicate a project because of this reason. There is no universal formula. As the Stour Space team has pointed out to us, their ecosystem-type model could be adapted for different (cultural) project uses (making, art, music or other). Hence this document only aims to act as guidance with some points of advice that span the numerous projects, but does not intend for a project to be replicated.

Acknowledgments

This document was compiled by public works with the support and time of a great group of collaborators of each of the Civic Spaces listed below.

Our thanks go to:

Pippa Gueterbock - LLDC

Rhianon Morgan Hatch

Laura May - Chats Palace

Juliet Can - Stour Space

Neil McDonald - Stour Space

Joe Walker - Old School Rooms & Round Chapel

Rob Trimble - Bromley By Bow Centre

Sally Anthony - Hub 67

Lucy Oliver-Harrison - The Yard Theatre

Keren Miller - Phoenix Community Housing (The Green Man)

Marie Porter - Phoenix Community Housing (The Green Man)

Steve Connor - Phoenix Community Housing (The Green Man)

Jim Ripley - Phoenix Community Housing - (The Green Man)

Valeria Karpova

Matteo Marchesini

Compiled by
public works
for

LONDON LEGACY
DEVELOPMENT
CORPORATION