

**THE EVOLUTION OF A CRAFT:  
POST-BYZANTINE BOOKBINDING BETWEEN THE LATE  
FIFTEENTH AND THE EARLY EIGHTEENTH CENTURY  
FROM THE LIBRARIES OF THE IVIRON MONASTERY IN  
MOUNT ATHOS/ GREECE AND THE ST. CATHERINE'S  
MONASTERY IN SINAI/ EGYPT.**

Volumes I, II, III

Georgios Boudalis

**Volume III**  
Appendices

PhD Thesis  
Camberwell College of Arts  
University of the Arts London

July 2004

# CONTENTS

## Contents

### VOLUME III

#### Appendices

List of contents.....	646
1. List of acronym abbreviations used in the thesis.....	648
2. List of tables.....	652
3. The tables with the data of the 128 bindings considered in the main text.....	656
4. The survey form and the description of the fields of the database .....	746
5. The complete list of the 593 decorative tools recorded in the research.....	828
6. Index of the bindings surveyed and the tools used.....	882
7. Index of the scribes of the manuscripts surveyed. ....	902
8. Glossary.....	914
9. Bibliography.....	916

## Appendix 1.

### List of acronym abbreviations used in the thesis

This tables contains acronymic abbreviations which are used both in the tables and the main text of the thesis, giving the meaning and the reference to the description of survey form in section 5.4. where all the terms are fully explained. Those, few, codifications which are not acronyms are not included in this table but explained in the description of the survey form in section 5.4.

CODIFIED DESIGNATION	MEANING	REFERENCE TO THE SURVEY FORM
N.k.	Not known	
N.v.	Not visible	
H.E	Head edge	
T.E.	Tail edge	
F.E.	Fore edge	
L	Left	
R	Right	
Ms	Manuscript	
pds	Pastedowns	
<b>Text-block</b>		
I.	Ivion codex	
S.	Sinai (Greek) codex	
S.A.	Sinai Arabic codex	
S.G.	Sinai Georgian codex	
S. Sl.	Sinai Slavonic codex	
T.	Theological	
L	Liturgical	
M	Music	
H	History	
C	Classics	
O	Other	
W.P.	Western paper	
W.p.P	Western polished paper	
E.P	Eastern paper	
E.p.P	Eastern polished paper	
V.P	Various papers	
Pap	Paper	
Par	Parchmnet	
N.K.	Not Known	
<b>Sewing</b>		
S	S ply	
Z	Z ply	
<b>Boards</b>		
pbs	Pasteboards	
bds	Boards	
BG1, etc	Boards (edge) groove	See appendix 1, p. 777
SET1, etc	Spine edge treatment	See appendix 1, p. 778
SER1 etc	Spine edge recesses (for the accommodation of the attachment thread or the sewing supports)	See appendix 1, p. 785

S.a.S.	Same as Sewing (thread)	
<b>Endbands</b>		
P.E.	Primary endband	
S.E	Secondary endband	
EAS 1 etc	Endband anchorage system	See appendix 1, p. 795
S.a.S.	Same as Sewing (thread)	
<b>Cover</b>		
T-ins 1 etc	Turn-ins (the shape of)	See appendix 1, p. 807
Co 1 etc	Corners (mittering, the shape of)	See appendix 1, p.808-809
Dec1 etc	Decoration (pattern)	See appendix 1, p. 811-813
BED 1 etc	Board edges decoration	See appendix 1, p. 813-814
SD1 etc	Spine decoration	See appendix 1, p. 815
MuF/a etc	Indicates the codified classification of the tools used for the decoration of the bindings	See appendix 1, p. 816-817
<b>Fastenings</b>		
S.a.C.	Same as Cover (material)	
D.t.C.	Different than Cover (material)	
AH 1 etc	Anchorage holes (arrangement)	See appendix 1, p. 824-825
TB	Traverse the boards	
TBT	Traverse the boards and turn-ins	
TBTP	Traverse the boards, turn-ins and pastedowns	
TBP	Traverse the boards and pastedowns	
NuC1	Nailed underneath the cover with 1 nail	
NuC2	Nailed underneath the cover with 2 nails	
NuCAP	Nailed underneath the cover with an anchor plate	
SuC	Stapled, (ends) underneath the cover	
SoC	Sewn on the cover	
TuP	Trimmed, (ends) underneath the pastedowns	
TpaP	Trimmed, (ends) pasted above the Pastedowns	
TfaP	Trimmed, (ends) free above Pastedowns	
Ufi	Untrimmed, (ends) free in the inside	
UpiaT	Untrimmed, (ends) pasted in the inside above Turn-ins	
UuP	Untrimmed, (ends) under pastedowns	
UpaP	Untrimmed, (ends) pasted above pastedowns	
UfaP	Untrimmed, (ends) free above pastedowns	
bCB	(ends) Between the cover and the boards	
bCAP	(ends) Between the cover and anchor plate	
TbPpPC	Trimmed, (ends) between the pastedowns and pasted paper cuttings	
UbPpPC	Untrimmed, (ends) between the pastedowns and pasted paper cuttings	
F & T 1 etc	Fastenings and turn-ins (arrangement)	See appendix 1, p. 826
M	Missing	
PM	Partly missing	
<b>Markers</b>		
S.a.E	Same (thread) as the one used for the endband	
S.a.S.E.	Same (thread) as the one used for the endband secondary sewing	
ItSp	Inserted through slit (in the leather cover) and pasted( on the board)	

FpbsL	Folded and pasted on both sides of the leaves	
FH (a) etc	Fastened on headband	See appendix 4, p. 802
LtH(a) etc	Laced through the headband	See appendix 4, p. 803
KiM	Knotted in the middle	See appendix 4, p. 804

## Appendix 2.

### List of tables.

#### **Cretan bindings of the fifteenth and sixteenth century**

- Table 2. Endleaves information
- Table 1. Text-block information
- Table 3. Sewing information
- Table 4. Boards information.
- Table 5. Spine lining information.
- Table 6. Endband core information.
- Table 7. Endband primary sewing information.
- Table 8. Endband secondary weaving information.
- Table 9. Cover information
- Table 10. Decoration information.
- Table 11. Tools information
- Table 12. Metal fittings information
- Table 13. Fastening information
- Table 14. Text-block edges decoration.

#### **The Antioch bindings**

- Table 15. Text-block information
- Table 16. Repair information
- Table 17. Endleaves watermarks information.
- Table 18. Endleaves information.
- Table 19. Sewing information.
- Table 20. Boards information.
- Table 21. Spine lining information.
- Table 22. Endband cores information.
- Table 23. Endband primary sewing information.
- Table 24. Endband secondary weaving information.
- Table 25. Markers information.
- Table 26. Cover information.
- Table 27. Decoration information.
- Table 28. Tools information
- Table 29. Metal fittings information
- Table 30. Fastenings information.
- Table 31. Text-block edges decoration information.

#### **The Klimis bindings.**

- Table 32. Text-block information.
- Table 33. Endleaves information.
- Table 34. Sewing information.
- Table 35. Boards information.
- Table 36. Spine lining information.
- Table 37. Endband cores information.
- Table 38. Endband primary sewing information.
- Table 39. Endband secondary weaving information.
- Table 40. Markers information.
- Table 41. Cover information.
- Table 42. Decoration information
- Table 43. Tools information
- Table 44. Metal fittings information.
- Table 45. Fastenings information.

Table 46. Text-block edges decoration information.

### **The Giglio bindings**

Table 47. Text-block information.

Table 48. Binders information.

Table 49. Repair information.

Table 50. Endleaves Information.

Table 51. Sewing Information.

Table 52. Boards Information

Table 53. Spine lining information.

Table 54. Endband cores information

Table 55. Endband primary sewing information.

Table 56. Endband secondary sewing / weaving information

Table 57. Markers information

Table 58. Cover Information

Table 59. Decoration information

Table 60. Tools information

Table 61. Metal fittings information

Table 62. Text-block edges decoration information.

Table 63. fastenings information.

### **The Cairo *metochion* bindings.**

Table 64. Text-block information.

Table 65. Binders information

Table 66. Repair information.

Table 67. Endleaves information.

Table 68. Sewing information

Table 69. Sewing thread information

Table 70. Boards information

Table 71. Spine lining information.

Table 72. Endband cores information.

Table 73. Endband primary sewing information.

Table 74. Endband secondary sewing information.

Table 75. Cover information.

Table 76. Decoration information.

Table 77. Tools information

Table 78. Metal fittings information.

Table 79. Fastenings information

### **The Elusive atelier bindings**

Table 80. Text-block information.

Table 81. Repair information

Table 82. Endleaves information.

Table 83. Sewing information.

Table 84. Sewing thread information.

Table 85. Boards information.

Table 86. Spine lining information.

Table 87. Endband cores information.

Table 88. Endband primary sewing information.

Table 89. Endband secondary sewing information.

Table 90. Markers information.

Table 91. Cover information.

Table 92. Cover Decoration information.

Table 93. Tools information.

Table 94. Edge decoration information.

Table 95. Metal fittings information.

Table 96. Fastenings information.

### **The Raithos bindings**

Table 97. Text-block information.

Table 98. Binding information.

Table 99. Repair information

Table 100. Endleaves information.

Table 101. Sewing information.

Table 102. Sewing Thread information.

Table 103. Boards information.

Table 104. Spine Lining information.

Table 105. Endband core information.

Table 106. Endband primary sewing type.

Table 107. Endband secondary sewing information.

Table 108. Markers information.

Table 109. Cover information.

Table. 110. Decoration information.

Table 111. Tools information.

Table 112. Text-block edges decoration information.

Table 113. Fastenings information.

### **The New library bindings**

Table 114. Text-block information.

Table 115. Binding information.

Table 116. Repair information.

Table 117. Endleaves information.

Table 118. Sewing information.

Table 119. Sewing thread and supports information.

Table 120. Boards information.

Table 121. Spine lining information.

Table 122. Endband cores information.

Table 123. Endband primary sewing information.

Table 124. Endband secondary sewing information.

Table 125. Markers information.

Table 126. Cover information.

Table 127. Decoration information.

Table 128. Tools information.

Table 129. Fastenings information.

### **The Iviron scriptorium bindings**

Table 130. Text-block information.

Table 131. Binders information.

Table 132. Repair information.

Table 133. Endleaves information.

Table 134. Sewing information.

Table 135. Boards information.

Table 136. Spine lining information.

Table 137. Endband cores information.

Table 138. Endband primary sewing information.

Table 139. Endband secondary sewing / weaving information.

Table 140. Markers information.

Table 141. Cover information.



- Table 142. Decoration information.  
Table 143. Tools information.  
Table 144. Metal fittings information.  
Table 145. Fastenings information.

### **The Theoclitos bindings**

- Table 146. Text-block information.  
Table 147. Repair information.  
Table 148. Endleaves information.  
Table 149. Sewing information.  
Table 150. Boards information.  
Table 151. Spine lining information.  
Table 152. Endband cores in formation.  
Table 153. Endband preliminary sewing type.  
Table 154. Secondary endband information.  
Table 155. Marker information.  
Table 156. Cover information.  
Table 157. Decoration information.  
Table 158. Tools information.  
Table 159. Fastenings information.

### **The Papanephitos bindings**

- Table 160. Text-block information  
Table 161. Binding information  
Table 162. Repair information.  
Table 163. Endleaves information.  
Table 164. Sewing information.  
Table 165. Boards information.  
Table 166. Spine lining information  
Table 167. Endband cores information.  
Table 168. Endband primary sewing information  
Table 169. Endband secondary sewing / weaving information  
Table 170. Markers information.  
Table 171. Cover information.  
Table 172. Decoration information.  
Table 173. Tools information.  
Table 174. Fastenings information.

### **The Cosmas Macedon bindings**

- Table 175. Text-block information.  
Table 176. Endleaves information.  
Table 177. Sewing information.  
Table 178. Sewing thread and sewing supports information.  
Table 179. Boards information.  
Table 180. Spine lining information.  
Table 181. Endband cores information.  
Table 182. Endband primary sewing information.  
Table 183. Endband secondary sewing information.  
Table 184. Markers information.  
Table 185. Cover information.  
Table 186. Decoration information.  
Table 187. Tools information.  
Table 188. Titling information.  
Table 189. Fastenings information.

## **Appendix 3**

CRETAN BINDINGS OF THE FIFTEENTH AND SIXTEENTH CENTURIES

Catalogue number	Text chronology	Title	Scribe/s	Format of text-block	Number of leaves	Notes	Original binding?
S 0165	15th c. 1 <sup>st</sup> half	Four Gospels (T)	Io[annis]	16mo (180 x 126)	430 Par/WP	Last text leaf: «Θεού το δώρον και ιω[άν]νου πόνος ρόσου το επίκληιον τάχα και θήτου»	Probably
S 0375	892/893	Sermons of J. Chrysostoms (T)	N.k.	4to (345 x 260)	438 Par/WP	f. 4v. «ετους ζψς' (7106 AM = 1608 AD) νοεμβρίω μηνί κ' ήλθα εγώ ο γεράσιμος ιερομόναχος εκ το οικονομίον της κρήτης και ήφερα το παρόν βιβλίον και το αφιερόνω εις το άγιον ημών μοναστήριον το σιναιον και όστις το ζενώση ή κόψη το φίλον να είναι αφορισμένος παρά των τη' θεοφόρων αγίων πατέρων και ασυγχώρητος παρά θεού παντοκράτορος και η μερίς αυτού μετά των επόντων άρον σταύρωσον τον υιόν του θεού». f. 436r. «απή η βιβλος έστην του εν αγίοις π(α)ρ(ό)ς ημών νικολάου του εν ρικουδι [An almost erased curse against book thieves follows] έτους ςαα' (6401 AM = 1103 AD) βασιλεύοντος του (ευσεβε?) σάτου λέοντος ισαύρου και αρχιερατέβαντος οικουμενικού [πατριάρχου?] κυρού σεργίου ου και τους οικους(?) επίτησ(εν)».	No, at least 2nd
S 0663	1520	Liturgy (L)	N.k.	8vo (215 x 145)	325 WP	f. 320v. «Εγράφη το παρόν βιβλίον δια εξόδου και συνδρομής του σιωπιτάτου εν μοναχοίς κυρ νικοδήμου εν έτη ζκη' (7028 AM = 1520 AD) εν μηνί μαρτίου εις τας κε'».	Yes
S 0968	1429	Euchologion (L)	Priest Bartholomaios (Rossos)	8vo (215 x 133)	484 Par	f. 483v. «Ετελειώθη το παρόν ευχολόγιον δια χειρός καμού του αμαθούς ταπεινού και αμαρτωλού βαρθολομαίου τάχα και ιερέως το επικλήν ρόσου δια συνδρομής και εξόδου του πανοσιπτάτου πατρός ημών μωνσέως διακόνου και οικονόμου της σφρασσίας μονής της αγίας ενόδου μεγαλομάρτυρος αικατερίνης εν τη νήσω κρήτη και οι εντυγχάνοντες εύχεσθαι ημών δια τον κύριον. Εν έτει εξακσιχλιωστώ σα λδ' (6934 AM = 1429 AD) μηνί αυγουστου ιε'». f. 484r. (right pastedown). «Τούτον το ευχολόγιον εγένετον δια την μεγάλην εκκλησίαν του αγίου προφήτου μωνσέως και της αγίας ενόδου μεγαλομάρτυρος αικατερίνης δια εξόδου και κόπου του έν μακαρία τη μηνίμ γεναμένου σεμνήστου δούλου του θεού μωνσέως ιεροδιακόνου ποτέ οικονόμου εν τη νήσω κρήτης. Όστις δε υστερήσει αυτό της αγίας μονής να έχει την άραν των επτά συνόδων και του αγίου μωνσέως κατάδικον. Εγράφη με το θέλημα του επισκόπου αγιωτάτου σάβα εις χιλίους τετρακοσίους είκοσι ενέα μηνί μαρτίω η' έτους δε αρχής κόσμου εξακσιχλιωστώ τριακοστώ ενόδιω».	Yes
S 1194	1491	Apolloniou Rodiou Argonautica(C)	Aristoboulos Apostolis	4to (310 x 204)	185 WP	f. 182r. «Αριστόβουλος Αποστόλης ιεροδιάκονος θεία χάριτι και ταύτην την του απολλωνίου βιβλον εν κρήτη εξέγραψα ούκ άνευ μέντοι μισθού υπό γάρ του εξολεστάτου θηρός της πενίας και αυτός ώσπερ ο πάτηρ μου στραργεύομαι αυθα' (1491 AD) μηνός δεκεμβρίου δ'».	Yes
S 1234	1469	Stichirarion (L)	Ioannis protopapas of Candia Plousiadenos	8vo (235 x 165)	459 WP	f. 450r. «ετούτο το στιχηράριον αφιείρωσε ο εν μακαρία τη μηνίμ ο οσιώτατος Ιωαννίκιος ιερομόναχος και πνευματικού πατρός. Αφιείρωσεν αυτό εις το άγιον και θεοβιάδιστον όρος το Σίνεον και ήτις το κλέψι ει κόψη το φίλον ετούτο, και ζενόσπι από το άγιον μοναστήρι να έχει τας άρας τον τι' και θεοφόρον πατέρων και να κρίνετε με τον ιούδα τον σκηρώτην». f. 450v. «Ετελειώθη η παρούσα βιβλος δια χειρός εμού ιωάννου ιερέως του πλουσιμανδανού (?) και προτόπαπα χάνδακος κρήτης έπι γενήν και άρχοντος των εκκλησιών έτι το από του κυρίου ημών ισοού χριστού αυθ' (1469 AD) ενδιπτιόνος γ' εν βενετίας. Όσοι ούν της βιβλου εντεύξησθε εύχεσθε προς κύριον υπέρ ημών και των ...»	Yes
S 1343	1464	Four Gospels (T)	N.k.	8vo (272 x 196)	345 WP	f. 337r. «Το θειον και ιερόν ευαγγέλιον ωνίατο ο κύριος οικονόμος αθανάσιος της μονής της αγίας Αικατερίνης εκ κρήτης, όστις δε βουληθήναι κλατέναι αυτό από του αγίου όρους σνά έχει τας άρας των τριακοσίων δεκα και οκτώ θεοφόρων πατέρων της έν νικαία και του αγίου επισκόπου της μονής του κυρίου Ιωακειμ και των αυτού αναδόχων, εν έτει ςσα οβ' (6972 AM = 1464 AD) εν μηνί ιουλίω κγ'».	No, at least 2nd
S 2101	1478	Menologion (L)	Mathaios	4to (287 x 220)	571 WP	f. 569r. «Ετελειώθη το παρόν βιβλίον κατά μήνα απρίλιον του ςσαβψς' (6986 AM = 1478 AD) έτους +γραφέν χειρί ματθαίου του ευτελοός ιερομονάχου του κατά κόσμον τραπεζούντιου τέλος τώ δόντι τέρμα της βιβλου θεώ χάρις».	Yes
S.A. 0080	1479	Four Gospels (T)	N.k.	4to (290 x 200)	194 Ep		Yes?

Table 1. Text-block information

Catalogue number	Original binding?	Date of Binding	Left endleaf unit arrangement	Right endleaf unit arrangement
S 0165	Yes	15th c.	[1] 3	3 [1]
S 0375	No, at least 2nd	16th c.	[1] +	3 [1]
S 0663	Yes	1520?	[1] 3 + 6	7 [1]
S 0968	Yes	1429?	Missing	+
S 1194	Yes	1491?	[1] 3	3 [1]
S 1234	Yes	1469?	[1] 3	3 [1]
S 1343	No, at least 2nd	15th c. 2nd-3rd quarter of?	6	+ 1 + 2
S 2101	Yes	1478?	[1] 3	+ 2 [1]
S.A. 0080	Yes?	1479?	[1] 3	+ 1 [1]

Table 2. Endleaves information

Catalogue number	Number of sewing stations	Distance between stations / Pattern of sewing stations	Accommodation nicks	Sewing thread	Sewing thread thickness	Spine joints	Attachment thread	Thickness of boards	Format of text-block	Number of leaves
S 0165	4	20-45-45-18 / B1	V-shaped cuts	Linen?	Thin/medium		SaS	11	16mo	430
S 0375	5	28-62-57-57-60-55 / D	V-shaped cuts	Linen	Medium/coarse		N.k.	14	4to	438
S 0663	4	13-55-67-61-13 / B1	V-shaped cuts	Hemp	Thin		N.k.	9	8vo	325
S 0968	4	22-55-65-53-20 / B2	V-shaped cuts	Linen	Medium		SaS	12	8vo	484
S 1194	5	16-66-65-65-25 / B1	V-shaped cuts	Linen	Thin		N.k.	8	4to	185
S 1234	5	12-50-52-54-51-11 / B1	Tiny V-shaped cuts	Linen	Medium		N.k.	10	8vo	459
S 1343	5	22-53-64-62-57-17 / B5	V-shaped cuts	Linen	Medium		N.k.	13	8vo	345
S 2101	5	15-65-63-63-62-18 / B1	V-shaped cuts	Linen	Medium		N.k.	13	4to	571
S.A. 0080	4	56-59-59-58-58 / A	V-shaped cuts	Hemp?	Medium		SaS	10	4to	194

Table 3. Sewing information

Catalogue number	Attachment system	Material	Dimensions	Board edge groove	Spine edge treatment	Spine joints	Attachment thread	Thickness of boards	Format of text-block	Thickness of text-block
S 0165	I Uns/3c	Hardwood	Flush	BC1	SET 3		SaS	11	16mo	70
S 0375	I Uns/3?	Wood	Flush	BG1	SET 3		N.k.	14	4to	90
S 0663	I Uns/1?	Hardwood	Flush	BG1	SET 3 or SET 4		N.k.	9	8vo	40
S 0968	I Uns/3c	Hardwood?	Flush	BG1	SET 3		SaS	12	8vo	73
S 1194	N.v.	Wood	Flush	BG1	SET 3	Very slight	N.k.	8	4to	29
S 1234	N.v.	Wood	Flush	BG1	SET 4	None	N.k.	10	8vo	78
S 1343	I Uns/3c	Hardwood	Flush	BG2	SET 3	Slight	N.k.	13	8vo	65
S 2101	N.v.	Wood	Flush	BG1	SET 4	90°?	N.k.	13	4to	92
S.A. 0080	I Uns/3c	Softwood?	Flush	BG2	SET 7	45°?	SaS	10	4to	58

Table 4. Boards information.

Catalogue number	Spine lining	Number of layers	Material	Thickness	Board covered	Side of boards covered	Spine shape	Thickness of text-block
S 0165	Yes, all along the spine	1	Canvas	Thin	N.k.	Outside	Round	70
S 0375	Yes, all along the spine	1	Canvas	Medium	35%	Outside	Round	90
S 0663	Yes, all along the spine	1	Canvas	Thin	N.k.	Outside	Round	40
S 0968	Yes, all along the spine	1	Canvas	Medium	N.k.	Outside	Slight round	73
S 1194	Yes, all along the spine	1	Canvas	Thin	N.k.	Outside	Slight round	29
S 1234	Yes, all along the spine	1	Canvas	Medium?	N.k.	Outside	Round	78
S 1343	Yes, all along the spine	1	Canvas	Medium	100%	Outside	Round	65
S 2101	Yes, all along the spine	1	Canvas	Medium	N.k.	Outside	Round	92
S.A. 0080	Yes, all along the spine	1	Canvas	Medium	55%	Outside	Slight round	58

Table 5. Spine lining information.

Catalogue number	Number of cores	Endband primary sewing (E. P. S.) type	First core material	Second core material	First core thickness	Second core thickness	Distance of projection	Endbands anchoring system	Format of text-block
S 0165	2	Greek double core	Cord	Cord	Medium	Medium	32mm-26.2%	N.v. (EAS 2?)	16mo
S 0375	2	Greek double core	Cord	Cord	Medium	Medium	28mm-12.2%	EAS 2	4to
S 0663	2	Greek double core	Cord	Cord	Medium	Medium	31mm-21.9%	EAS 2	8vo
S 0968	2	Greek double core	Cord	Cord	Medium	Medium	28mm-21%	EAS 2	8vo
S 1194	2	Greek double core	Cord	Cord	Medium	Medium	25mm-12.6%	EAS 2	4to
S 1234	2	Greek double core	Cord	Cord	Medium	Medium	30mm-20.6%	N.v. (EAS 2?)	8vo
S 1343	2	Greek double core	Cord	Cord	Medium	Medium	40mm-20.3%	N.v. (EAS 2?)	8vo
S 2101	2	Greek double core	Cord	Cord	Medium	Medium	39mm-18.6%	EAS 2	4to
S.A. 0080	2	Greek double core	Cord	Cord	Medium	Medium	33mm-15.8%	EAS 2	4to

Table 6. Endband core information.

Catalogue number	E. P. S. type	Endband secondary weaving (E. S. W.) type	E. P. S. thread	E. P. S. thread thickness	E. P. S. twist	E. P. S. thread ply	Number of tie-downs	Tie-downs position	Thread anchorage
S 0165	Greek double core	Cretan on single warps	Linen (SaS)	Medium	Tight	Multiple S	As many as gatherings	Centre-fold	Uses change-over station
S 0375	Greek double core	None	Linen	Medium	Loose	Multiple S	As many as gatherings	Centre-fold	Uses change-over station
S 0663	Greek double core	Cretan on double warps	Hemp	Medium	Medium	2S	N.k.	Centre-fold	Uses change-over station
S 0968	Greek double core	Cretan on single warps	Linen	Medium	Tight	3 2s Z	As many as gatherings	Centre-fold	Uses change-over station
S 1194	Greek double core	Cretan on single warps	Linen (SaS)	Thin	Medium	4S	N.k.	Centre-fold	Uses change-over station
S 1234	Greek double core	Cretan on double warps	Linen (SaS)	Medium	Loose	?S	N.k.	Centre-fold	Uses change-over station
S 1343	Greek double core	Cretan on ? warps	Linen	Thin	Medium	2Z	As many as gatherings	Centre-fold	Uses change-over station
S 2101	Greek double core	Cretan on double warps	Linen (SaS)	Medium	Medium	Multiple S	As many as gatherings	Centre-fold	Uses change-over station
S.A. 0080	Greek double core	Cretan on double warps	Linen	Medium	N.k.	N.k.	As many as gatherings	Centre-fold	Uses change-over station

Table 7. Endband primary sewing information.

Catalogue number	E. S. W. type	E. S. W. thread	E. S. W. thread colours	E. S. W. thread thickness	E. S. W. thread ply	E. S. W. thread twist
S 0165	Cretan on single warps	Linen / Silk	Natural / Blue, red	Medium / Medium	2S / 3(?)S	Loose, / Loose
S 0375	None	-	-	-	-	-
S 0663	Cretan on double warps	Linen / Silk	Natural / Green, red, white	Medium / Medium	N.k. / ?S	N.k. / Medium
S 0968	Cretan on single warps	Hemp / Silk	Natural / Red, yellow	Medium / Medium	2S / 2S	Loose / Medium
S 1194	Cretan on single warps	Silk / Silk	Green / Green, red, white	Thin / Thin	N.k. / N.k.	N.k. / N.k.
S 1234	Cretan on double warps	Linen / Silk	Natural / Green, red, white	Thin / medium	2 2S / 2 2S	Tight / Medium?
S 1343	Cretan on ? warps	N. k. / Silk	N.k. / Green, red, white	N. k. / Medium	N.k. / 2S	N.k. / Tight
S 2101	Cretan on double warps	Linen / Silk	Natural / Green, red, white	Thin / Medium	N.k. / N.k.	N.k. / N.k.
S.A. 0080	Cretan on double warps	Linen / Silk	Natural / Green, red, white	Thin / Medium	N.k. / N.k.	N.k. / N.k.

Table 8. Endband secondary weaving information.

Catalogue number	Cover material	Cover colour	Turn-ins type	Turn-ins width	Corners mitre
S 0165	Goat ? leather	Light Brown	T-ins 5	Medium	Co 1
S 0375	Goat leather	Red-brown	T-ins 3	Varies	Varies
S 0663	Goat ? leather	Red-brown	T-ins 3	Varies	Co 1, Co 13?
S 0968	Goat ? leather	Red-brown	T-ins 3	Varies	Varies
S 1194	Goat leather	Red-brown	T-ins 5	Narrow	Co 1, Co 7
S 1234	Goat leather	Brown	T-ins 5	Varies	Co 1,
S 1343	Goat leather	Brown	T-ins 1, T-ins 2	Wide	Co 1
S 2101	Goat leather	Brown	T-ins 2	Medium	Co 1
S.A. 0080	Silk textile	Red	T-ins 3	Varies	Varies

Table 9. Cover information

Catalogue number	Left / right difference	Decoration patterns	Spine decoration pattern	Board edges decoration pattern	Decoration tools	Number of tools
S 0165	No	Dec2ab	SD4?/B	None	MuF/a63, MuF/d31, MuF/d32, MuF/d33, MuF/e2, MuA/a13, MuA/b4(?), MuG/a22, MuV15, C1	10
S 0375	Yes	Dec2abc(L), Dec6abcV (R)	None	None	MuF/a62, MuF/c38, MuF/d26, MuF/d28, MuF/d29, MuF/e42, MuA/a14, MuA/c8, C1	9
S 0663	No	Dec10ab	None	None	MuF/a13, MuF/d10, MuF/d29, MuA/a3, MuA/c2, MuA/c4, C1	7
S 0968	No	Dec1ab	None	None	MuF/c40, MuF/d38, MuA/a13(?), MuA/b10, MuG/a13(?), MuV15, fillets	7
S 1194	No	Dec2abc	None	None	MuF/a66, MuF/d20, MuF/d27, MuF/d31, MuF/d33, MuF/e35, MuA/c7, MuG/b11, MuG/c11, fillets	10
S 1234	Yes	Dec1abc(L), Dec2ab(R)	None?	BED 10	MuF/a66, MuF/d31, MuF/d32, MuF/d33, MuF/e2, MuF/e35, MuA/c7, fillets	8
S 1343	No	None	None	None	None	0
S 2101	Yes	Dec1ab, (R), Dec1abc(L)	None	BED 10	MuF/a62, MuF/c38, MuF/d26, MuF/d28, MuF/d29, MuA/a14, MuA/c8, unclear concentric rings tool, fillets	8
S.A. 0080	No	None	None	None	None	0

Table 10. Decoration information.

Tool	Volumes where it is used	Number of volumes where it is used
MuF/a13	S. 663	1
MuF/a62	S. 375	1
MuF/a63	S. 165	1
MuF/a66	S. 1194, S. 1234	2
MuF/d10	S. 663	1
MuF/d20	S. 1194	1
MuF/d26	S. 375	1
MuF/d27	S. 1194	1
MuF/d28	S. 375	1
MuF/d29	S. 375, S. 663	2
MuF/d31	S. 165, S. 1194, S. 1234, S. 2101	4
MuF/d32	S. 165, S. 1234, S. 2101	3
MuF/d33	S. 165, S. 1194, S. 1234, S. 2101	4
MuF/d38	S. 968	1
MuF/c38	S. 375, S. 2101	2
MuF/c40	S. 968	1
MuF/e2	S. 165, S. 1234	2
MuF/e35	S. 1194, S. 1234	2
MuF/e42	S. 375	1

Tool	Volumes where it is used	Number of volumes where it is used
MuV15	S. 165, S. 968	2
MuA/a3	S. 663	1
MuA/a13	S. 165	1
MuA/a14	S. 375, S. 2101	2
MuA/b4	S. 165	1
MuA/b10	S. 968	1
MuA/c2	S. 663	1
MuA/e4	S. 663	1
MuA/c7	S. 1194, S. 1234, S. 2101	3
MuA/c8	S. 375	1
MuG/a13(?)	S. 968	1
MuG/a22	S. 165	1
MuG/b11	S. 1194	1
MuG/c11	S. 1194	1
Unidentified concentric rings tool	S. 2101	1
CI	S. 165, S. 375, 663	3
Filets	S. 968, S. 1194, S. 1234, S. 2101	4

Table 11. Tools information

Catalogue number	Metal furniture type	Number of Furniture	Attachment method	Metal	Format of text-block	Thickness of text-block
S 0165	Bas-relief plaques & Bosses on both boards	13 (-13) L, 8 (-8) R	Nailed, ends barely visible	N.k.	16mo	70
S 0375	Bosses	5 (-2) L, 5 (-1) R	Nailed, ends flattened above pds	Copper alloy ?	4to	90
S 0663	Bosses	5 L, 5 R	Nailed,, ends not visible	Copper alloy	8vo	40
S 0968	Bosses?	Board missing 5 (-5) R	N.k.	N.k.	8vo	73
S 1194	Bosses	5 L, 5 (-2) R	Nailed, ends flattened above pds	Bronze?	4to	29
S 1234	Bosses	5 L, 5 R	Nailed, ends not visible	Bronze?	8vo	78
S 1343	Bas-relief plaques (L), Bosses (R)	13 (13) L, 4 (-4) R	Nailed, ends not visible	N.k.	8vo	65
S 2101	Bosses	5 (-4) L, 5 (-5) R	Nailed ends not visible	Copper alloy ?	4to	92
S.A. 0080	Bosses	5 (-2) L, 4 R	Nailed, ends not visible	Copper alloy	4to	58

Table 12. Metal fittings information

Catalogue number	Number of fastenings	Fastenings type	Fastenings material	Fastenings & T-ins arrangements	Strap anchorage type	Ends form	Arrangement of anchorage holes	Metal components
S 0165	1-2-1 ←	Three edged leather interlaced straps / Nk	Brown and white leather (DtC) and metal	F & T 2	TB	TfaP	AH 4	Ring (M) & cast metal compound pins
S 0375	0-2-0 ←	Three edged leather interlaced straps / Nk	-	F & T 8	TBTP	UfaP	AH 4 long distance	Rings (M) & pins (M)
S 0663	0-2-0 ←	Three edged leather interlaced straps / standard type	DtC and metal	F & T 1	TB	UfaP	AH 4	Rings & simple filed metal pins
S 0968	0-2-0 ←	Three edged leather interlaced straps / Nk	-	F & T 2	TBP	N.k.	AH4	Rings (M) & pins (M)
S 1194	0-2-0 ←	Three edged leather interlaced straps / Nk	SaC and metal	F & T 2	TB	UfaP	AH4	Rings (M) & cast metal compound pins
S 1234	0-2-0 ←	Three edged leather interlaced straps / Nk	DtC and metal	F & T 2	TB	UfaP	AH 4	Rings (M) & cast and filed metal compound pins
S 1343	0-2-0 ←	Three edged silk braided straps	Red and pink silk threads and metal	F & T 3	TB	UpaP	AH 4	Rings (M) & cast metal compound pins
S 2101	0-2-0 ←	Three edged leather interlaced straps / Nk	SaC and metal	F & T 2	TBTP	UfaP	AH 4 long distance	Rings (M) & cast metal compound pins
S.A. 0080	0-2-0 ?	Unclear	N.k. (Missing)	N.k.	TB	N.k.(missing)	AH 4	None?

Table 13. Fastening information

Catalogue number	Text-block edges decoration	Colours
S 0165	Drawn and painted motifs	Colours now very much faded
S 0375	Drawn and painted motifs	Red, brown (?)
S 0663	Drawn and painted motifs	Red, black
S 0968	None	-
S 1194	Drawn and painted motifs	Red, brown
S 1234	Drawn and painted motifs	Red black (?)
S 1343	None	-
S 2101	Drawn and painted motifs	Red, black (?)
S.A. 0080	Gaufered and gilded	Gold

Table 14. Text-block edges decoration information.



## THE ANTIOCH BINDINGS

Catalogue number	Text chronology	Title	Scribes/s	Format of text-block	Number of leaves	Notes	Original binding?
S 0030	9th c.	Psalter (T)	N.k.	16mo (182 x 115)	427 Par/WP/EP		No, at least 2nd
S 0806	16th c (1 <sup>st</sup> half?)	Paraklitiki (L)	N.k.	8vo (217 x 140)	391 WP		Yes
S 0975	16th c.	Euchologion (L)	N.k.	8vo (210 c 158)	402 WpP	The text-block consists of different distinct parts sewn together.	Yes Partly
S 1991	14th -15th c.	Four Gospels (T)	N.k.	8vo (200 x 150)	320 WpP	The last text gathering is not part of the original text-block; it was probably added during the rebinding.	No, at least 2nd
S A. 0089	1285	Four Gospels (T)	N.k.	4to (280 x 215)	194 EpP	f.163r. There is a note which says that the manuscript was written by a monk though giving no name. There is also a note saying that a certain Klimis '... took care of the papers'. f.193v. There is a note saying that the manuscript was read by Metropolitan of Bethlehem named Hioakim Bassam.	No, at least 2nd
S A. 0170	1285	Lectionary (L)	N.k.	4to (285 x 220)	209 EpP	Folios 1-194 are written in Arabic starting from the right board proceeding to the left board. Folios 194-207 are written both in Arabic and Greek with an inverse text procedure from the left board to the right board.	No, at least 2nd
S.A. 0334	1321	Discourses of St John Klimax (T)	Arsenios	4to (298 x 195)	190 EpP	f. 184 r. There is a note saying that the manuscript was written by Arsenios in 6829 AM = 1321 AD for the <i>katholikon</i> of the monastery during the service of Germanos as archbishop of the monastery.	No, at least 2nd
S.A. 0340	13th c.	Discourses of St John Klimax (T)	Efraim from Tripoli	8vo (240 x 160)	325 EpP	f. 323v. There is a note in Arabic saying that the manuscript was written in the monastery by Ephraim from Tripoli for the church of the Forty Martyrs. f. 352r. A note saying that the manuscript was seen by Paul oikonomos of the monastery in the house of Moses in Gaza and that its leaves were detached and dispersed.	No, at least 2nd
S.A. 0409	13th c.	Liturgica, Services (L)	Hioannis tou Douka from Antioch	4to (317 x 215)	203 EpP	f. 194v. There is a note saying that the manuscript was read by a priest in Sainnaia (Syria) when Eugenios was Archbishop (1575-1583 AD) in the St. Catherine's monastery in Sinai. f. 195r. There is a note saying that the manuscript contains a speech by Patriarch Germanos of Constantinople which has been translated into Arabic by deacon Ioannis tou Douka from Antioch.	No at least 2nd

**Table 15. Text-block information**

Catalogue number	Original binding?	Spine-fold repairs type and material
S 0030	No, at least 2nd	Locally on eastern paper gatherings by pasting strips of similar eastern paper. Also overcasting on eastern paper gatherings and running stitch on parchment gatherings.
S 0806	Yes	None
S 0975	Yes Partly	Overcasting in the last (left) gatherings.
S 1991	No, at least 2nd	In several bifolia with paper strips pasted all along the spine-fold.
S A. 0089	No, at least 2nd	Plain and Ms waste paper strips pasted locally in the spine-fold of some of the outermost gatherings. Also some overcasting.
S A. 0170	No, at least 2nd	Some overcasting
S.A. 0334	No, at least 2nd	Plain paper strips pasted locally in the spine-folds
S.A. 0340	No, at least 2nd	Ms paper waste strips pasted locally
S.A. 0409	No, at least 2nd	Plain paper strips pasted locally in the spine-folds

Table 16. Repair information

Catalogue number	Date of Binding	Original binding?	Endleaves watermark	Binder
S 0030	15th - 16th c. (late-early)?	No, at least 2nd	The right endleaves are made of western paper with a grape watermark dated end of 15th beginning of 16th century. The left endleaves have a crown watermark not found in Briquet and Harfinger.	N.k.
S 0806	16th c (1 <sup>st</sup> half?)	Yes	Open palm with flower dated first half of 16 <sup>th</sup> c. Same found on L. 1588 (dated 1544), L. 663 (dated 1520), S. 663 (dated 1520) S. 1110 (dated 16th c. before 1523)	N.k.
S 0975	16th c. (1 <sup>st</sup> half?)	Yes Partly	N.k.	N.k.
S 1991	15th- 16th c (late-early)?	No, at least 2nd	Yes, in the right endleaves Balance like Briquet 2508 dated in 1481, 1496, 1517	N.k.
S A. 0089	15th -16th c. (late-early)?	No, at least 2nd	No	Klimis?
S A. 0170	15th -16th c. (late-early)?	No, at least 2nd	Yes, ring, similar to Briquet 689 dated 1457-1470))	Klimis?
S.A. 0334	End of 15 <sup>th</sup> century?	No, at least 2nd	N.k.	N.k.
S.A. 0340	16th c. (1 <sup>st</sup> half?)	No, at least 2nd	N.k.	N.k.
S.A. 0409	16th c. (1 <sup>st</sup> half)	No, at least 2nd	N.k.	N.k.

Table 17. Endleaves watermarks information.

Catalogue number	Original binding?	Left endleaf unit arrangement	Right endleaf unit arrangement
S 0030	No, at least 2nd	[1] 3	3 [1]
S 0806	Yes	4	+2
S 0975	Yes Partly	[1] +	\\1 [1]
S 1991	No, at least 2nd	4	+2
S A. 0089	No, at least 2nd	1+	+1
S A. 0170	No, at least 2nd	[1] 1	1 [1]
S.A. 0334	No, at least 2nd	None	Unclear
S.A. 0340	No, at least 2nd	2	2
S.A. 0409	No, at least 2 <sup>nd</sup>	3 +	None

Table 18. Endleaves information.

Catalogue number	Number of sewing stations	Distance between stations/ Pattern of sewing stations	Accommodation nicks	Sewing thread	Sewing thread thickness	Sewing thread twist	Sewing thread ply	Format of text-block	Number of leaves
S 0030	5	11-11-54-55-16-17 / B6	V-shaped cuts	Hemp	Medium	Medium	2S	16mo	427
S 0806	5	20-24-65-65-25-18 / B4B6	V-shaped cuts	Linen	Medium	Medium	2S	8vo	391
S 0975	5	10-21-70-72-15-17 / B4B6	V-shaped cuts	Hemp	Medium	Loose	?S	8vo	402
S 1991	4	25-42-55-47-38 / B2	V-shaped cuts	Hemp	Medium	Loose	?S	8vo	320
S A. 0089	4	40-72-74-70-33 / B1	V-shaped cuts	Hemp	Medium	Medium	?S	4to	194
S A. 0170	4	30-73-72-71-32 / B1	Single knife cuts	Cotton(?) waxed	Medium	Loose?	multiple Z	4to	209
S.A. 0334	3	40-105-110-40 / B1	V-shaped cuts	Linen waxed	Medium	Medium	?S	4to	190
S.A. 0340	3	40-85-85-31 / B1	V-shaped cuts	Hemp	Medium	Tight	?S	8vo	325
S.A. 0409	3	75-80-83-76 / A B1	V-shaped cuts	Hemp	Medium	Medium	?S	4to	203

Table 19. Sewing information.

Catalogue number	Attachment system	Attachment thread	Material	Dimensions	Boards edge groove	Spine edge treatment	Spine joints	Thickness of boards	Format of text-block	Thickness of text-block
S 0030	I Uns/3C	N.K.	Hardwood?	Flush	None	SET 3	45°	10	16mo	97
S 0806	I Uns/3C	SaS	Hardwood	Flush	None	SET 4	45°	10	8vo	57
S 0975	I Uns/1C	SaS	Wood	Flush	BG 2	SET 3	100°	12	8vo	60
S 1991	I Uns/3C	SaS	Hardwood?	Flush	None	SET 4	45°	13-14	8vo	50
S A. 0089	I Uns/3C (originally I Uns/1)	SaS	Hardwood	Flush	None	SET 3	90°	11	4to	38
S A. 0170	I Uns/3B	SaS	Wood	Flush	BG 2	SET 3	90°	12	4to	40
S.A. 0334	I Uns/1D	SaS	Acacia (?) wood	Flush	None	SET 3(L), SET 4(R)	160°	11	4to	61
S.A. 0340	I Uns/3B	N.K.	Hardwood	Flush	None	SET 3	160°	8	8vo	80
S.A. 0409	I Uns/3B	N.K.	Wood	Flush	None	SET 3	45°	12	4to	52

Table 20. Boards information.

Catalogue number	Spine lining	Number of layers	Material	Thickness	Board covered	Side of boards covered	Spine shape	Thickness of text-block
S 0030	Yes, all along the spine	1	Canvas	Medium	100%	Outside	Round	97
S 0806	Yes, all along the spine	1	Canvas	Medium	30%	Outside	Round	57
S 0975	Yes, all along the spine	1	Canvas	Medium	N.k.	Outside	Round	60
S 1991	N.v.	N.k.	N.k.	N.k.	N.k.	N.k.	Round	50
S.A. 0089	Yes, all along the spine	1	Canvas	Medium	30%	Outside	Round	38
S.A. 0170	Yes, between stations and all along the spine	2	Paper between stations/ Canvas all along the spine	Thin / Thin	N.k. / 50% ?	Outside/ Outside	Slight round	40
S.A. 0334	Yes, all along the spine	1	Canvas	Medium	40%	Outside	Slight round	61
S.A. 0340	Yes, all along the spine	1	Canvas	Medium	50%	Outside	Heavy round	80
S.A. 0409	Yes, all along the spine	2	Canvas / Blue canvas	Medium / Medium	30% / 30%	Outside/ Outside	Slight round	52

Table 21. Spine lining information.

Catalogue number	Number of cores	Endband primary sewing (E. P. S.) type	First core material	Second core material	First core thickness	Second core thickness	Distance of projection	Endband anchoring system	Format of text-block
S 0030	2	Greek double core	Cord	Cord	Medium	Medium	28 mm - 26.6%	EAS 2	16mo
S 0806	2	Greek double core	Cord	Cord	Medium	Medium	35 mm - 25.9%	EAS 2	8vo
S 0975	2	Greek double core	Cord	Cord	Medium	Medium	20 mm - 13.7%	EAS 3 ?	8vo
S 1991	2	Greek double core	Cord	Cord	Medium	Medium	26 mm - 20.6%	EAS 2	8vo
S.A. 0089	2	Greek double core	Cord?	Cord?	Medium	Medium	45 mm - 21.4%	EAS 2	4to
S.A. 0170	2	Greek double core	Cord	Cord	Medium	Medium	41 mm - 19.4%	EAS 2	4to
S.A. 0334	2	Greek double core	Cord	Cord	Medium	Medium	48 mm - 17.8%	EAS 3	4to
S.A. 0340	2	Greek double core	Cord	Cord	Medium	Medium	27 mm - 18.6%	EAS 2	8vo
S.A. 0409	2	Greek double core	Cord	Cord	Medium	Medium	50 mm - 24.3%	EAS 3	4to

Table 22. Endband cores information.

Catalogue number	E. P. S. type	Endband secondary weaving (E. S. W.) type	E. P. S. thread	E. P. S. thread thickness	E. P. S. thread twist	E. P. S. thread ply	Number of tie-downs	Tie-downs position	Thread anchorage
S 0030	Greek double core	None	Linen?	Medium	Medium	2S	As many as gatherings	Centre-fold	Uses change-over station
S 0806	Greek double core	Cretan on single warps	Linen (SaS)	Thick	Medium	2S	As many as gatherings	Centre-fold	Uses change-over station
S 0975	Greek double core	None	Hemp (SaS)	Medium	Medium	?S	As many as gatherings	Centre-fold	Uses other passing hole inside
S 1991	Greek double core	Cretan on double warps	Linen	Thin	Tight	2S	As many as gatherings?	Centre-fold	Uses change-over station
S.A. 0089	Greek double core	Cretan on double warps	Linen	Thick	Tight	3Z	As many as gathering	Centre-fold	Uses change-over station
S.A. 0170	Greek double core	Cretan on double warps	Hemp	Thick	Medium	2S	As many as gatherings	Centre-fold	Uses other passing hole outside
S.A. 0334	Greek double core	None	Linen	Medium	Medium	2S	As many as gatherings	Centre-fold	Uses other passing hole outside
S.A. 0340	Greek double core	None	Linen	Medium	Medium	2S	As many as gatherings	Centre-fold	Uses change-over station
S.A. 0409	Greek double core	None	Linen	Medium	Medium	2S	As many as gatherings	Centre-fold	Uses change-over station

Table 23. Endband primary sewing information.

Catalogue number	E. S. W. type	E. S. W. thread	E. S. W. thread colours	E. S. W. thread thickness	E. S. W. thread ply	S. W. thread twist
S 0030	None	-	-	-	-	-
S 0806	Cretan on single warps	Linen (SaS) / Silk	Natural / Green, red, white	Medium / thin	2S	Medium
S 0975	None	-	-	-	-	-
S 1991	Cretan on single warps	Linen / Silk	Natural / Green, red, white	Medium / thin	2S	Tight
S A. 0089	Cretan on single warps	Silk / Silk	White / Green, red, white, blue	Thin / thin	2Z	Medium
S A. 0170	Cretan on single warps	Cotton / Silk	Natural / Green, red, white, blue, pink	Medium / thin	2S	Medium
S A. 0334	None	-	-	-	-	-
S A. 0340	None	-	-	-	-	-
S A. 0409	None	-	-	-	-	-

Table 24. Endband secondary weaving information.

Catalogue number	Marker	Primary marker	Primary marker material & colour	Primary M way of attachment	Secondary marker	Secondary marker material & colour	Secondary M way of attachment
S 0030	Unclear (vestiges)	N.k.	S a E.	-	-	-	-
S 0806	Compound	Simple plaited open loop.	White silk (SaE)	LtH(f)	1 simple string	Natural hemp	KIE?
S 0975	None	-	-	-	-	-	-
S 1991	Simple	3 multicoloured thread strings / leaf tab markers	Green, red, white silk (S.a.E.) / green leather	LtH(f) / FpbsL but trimmed to the edge	-	-	-
S A. 0089	Simple	Leaf tab markers / Board tab-markers on both boards	Brown leather & blue canvas / Leather	TpbsL / ItSp	-	-	-
S A. 0170	Simple	1 simple string	Off-white linen 2 2S	FH(c)	-	-	-
S A. 0334	None	-	-	-	-	-	-
S A. 0340	None	-	-	-	-	-	-
S A. 0409	Simple	Leaf tab markers	Blue canvas	FpbsL	-	-	-

Table 25. Markers information.

Catalogue number	Cover material	Cover colour	Turn-ins type	Turn-ins width	Corners mitre
S 0030	Goat ? leather	Light brown	T-ins 3	Varies	Varies
S 0806	Goat leather	Red-Brown	T-ins 3, T-ins 5	Wide	Co 1
S 0975	Sheep ? leather	Brown yellow	T-ins 2	Wide	Varies
S 1991	Goat ? leather	Brown	T-ins 2, T-ins 3	Varies	Varies
S A. 0089	Sheep ? leather	Light red	T-ins 3, T-ins 5	Varies	Co 1
S A. 0170	Goat leather	Red-brown	T-ins 3	Wide	Co 1, Co 6
S.A. 0334	Sheep ? leather	Light brown-red	T-ins 2, T-ins 3	Medium	Co 1, Co 7
S.A. 0340	Goat leather	Dark brown	T-ins 3	Varies	Co 1, Co 6 (knife marks on boards)
S A. 0409	Goat leather	Red-brown	T-ins 1	Varies	Co 1 (knife marks on boards)

Table 26. Cover information.

Catalogue number	Left / Right difference ?	Decoration patterns	Spine decoration pattern	Board edges decoration pattern	Decoration motives	Number of tools
S 0030	Yes	Dec 1 (L), Dec 3 (R)	Nk (missing)	None	MuF/a71, MuF/e25, MuA/b7, C2	4
S 0806	Yes	Dec 1a (L), Dec 2a (R)	None	None	MuF/a69, MuF/a71, MuF/a78, MuF/c26, MuF/d23, MuF/e25, MuA/a10, MuA/b11, MuA/b17, MuG/a15, MuG/b3, MuG/b8, MuV11, C2	14
S 0975	Yes	Dec 1abc(L), Dec 2a(R)	None	None	MuF/a71, MuF/a78, MuF/c26, MuF/d23 MuF/e25, MuA/b17, MuG/b3, C2	8
S 1991	Yes	Dec 1ab (L), Dec 4a 1 (R)	SD7/B	BED 5 (MuG/a19, MuF/a68)	MuF/a68, MuA/b15, MuG/a19, C3?	4
S A. 0089	Yes	Dec 1abc (L), Dec 3a (R)	Other	BED 5 (MuA/b13), BD 10	MuF/a71, MuF/d37, MuF/e25, MuA/b13, MuG/a6(?), C2	6
S A. 0170	No	Dec 1ab	None	BED 10	MuF/a71, MuF/c28, MuF/d22, MuF/e25, MuA/a11, MuA/b13, MuA/b18, MuA/c6, C2	9
S.A. 0334	Yes	Dec 10a1 (L), Dec 1ab & other (R)	None	None	MuA/b13, MuV17, MuV 18, C3	4
S.A. 0340	No	Dec 3a	Other	BED 5 (MuA/d2)	MuF/a71, MuF/e25, MuA/b17, MuA/c3, C2	5
S.A. 0409	No	Dec 1a	SD7 / B	None	MuF/a71, MuF/d22, MuF/e36, MuA/a11, MuA/c6, MuA/c9, C2	7

Table 27. Decoration information.

Tool	Volumes where it is used	Number of volumes where it is used
MuF/a68	S. 1991	1
MuF/a69	S. 806	1
MuF/a71	S. 30, S. 806, S. 975, S.A. 89, S.A. 170, S.A. 340, S.A. 409	7
MuF/a78	S. 806, S. 975	2
MuF/c26	S. 806, S. 975	2
MuF/c28	S.A. 170	1
MuF/d22	S.A. 170, S.A. 409	2
MuF/d23	S. 806, S. 975	2
MuF/d37	S.A. 89	1
MuF/e25	S. 30, S. 806, S. 975, S.A. 89, S.A. 170, S.A. 340	6
MuF/e36	S.A. 409	1
MuA/a10	S. 806	1
MuA/a11	S.A. 170, S.A. 409	2
MuA/b7	S. 30	1
MuA/b11	S. 806	1
MuA/b13	S.A. 89, S.A. 170, S.A. 334	3

**Table 28. Tools information**

Tool	Volumes where it is used	Number of volumes where it is used
MuA/b15	S. 1991	1
MuA/b17	S. 806, S. 975, S.A. 340	3
MuA/b18	S.A. 170	1
MuA/c3	S.A. 340	1
MuAc6	S.A. 170, S.A. 409	2
MuA/c9	S.A. 409	1
MuG/a6	S.A. 89	1
MuG/a15	S. 806	1
MuG/a19	S. 1991	1
MuG/b3	S. 806, S. 975	2
MuGb8	S. 806	1
MuV11	S. 806	1
MuV17	S.A. 334	1
MuV18	S.A. 334	1
C2	S.30, S. 806, S. 975, S.A. 89, S.A. 170, S.A. 340, S.A. 409	7
C3	S. 1991, S.A. 334	2

Catalogue number	Metal furniture type	Number of Furniture	Attachment method	Metal	Format of text-block	Thickness of text-block
S 0030	Board edge nails	6 H.E. 4 F.E. 6 T.E.	Nailed	Iron?	16mo	97
S 0806	Bosses	5 (-2) L,	Nailed, ends flattened above t-ins	Copper alloy	8vo	57
S 0975	None	-	-	-	8vo	60
S 1991	Bosses (L) and plaques (R)	7 (-7) plaques L, 5 (-5) bosses R	Nailed	Copper alloy	8vo	50
S A. 0089	Bosses (L) and plaques (R)	5 (-5) plaques L, 4 bosses R	Nailed ends not visible	Copper alloy	4to	38
S A. 0170	Bosses	5 (-2) L, R	Nailed, ends underneath pds	Copper alloy	4to	40
S.A. 0334	None	-	-	-	4to	61
S.A. 0340	None	-	-	-	8vo	80
S.A. 0409	None	-	-	-	4to	52

**Table 29. Metal fittings information**

## THE KLIMIS BINDINGS

Catalogue number	Text chronology	Title	Scribe	Format of text-block	Number of leaves	Notes	Original binding?
S 0216	12th c. / 2nd half & 15th c.	Gospels (T)	N.k.	4to (320 x 220)	273 Par		No, at least 2nd
S 0420	10th- 11th c.	John Climax (T)	N.k.	8vo (250 x 195)	226 Par		No, at least 2nd
S 0604	15th-16thc.	February Meneon (L)	N.k.	4to (310 x 210)	170 WpP	At the end: <i>«μνέον αγίου όρουσ σινά και ήρις σεριόσι αυτώ εκ του χοροό του καθολικού να έχι την οργήν του θεοό και πάντων των αγίων».</i>	No, at least 2nd
S 1793	16th c.	October Meneon (L)	N.k.	4to (288 x 208)	272 WpP		Probably yes
S.A. 0076	13th c.	New Testament (T)	N.k.	8vo (275 x 205)	323 EpP		No, at least 2nd

**Table 32. Text-block information.**

Catalogue number	Original binding?	Date of binding	Left endleaf arrangement	Right endleaf unit arrangement	Watermarks
S 0216	No, at least 2nd	16 <sup>th</sup> c. (2 <sup>nd</sup> half?)	[1] 5	5 [1]	Anchor within circle very close to Briquet 567 and 568 dated in 1588 and 1597 AD respectively. There is also a countermark "Vb" which is missing in Briquet.
S 0420	No, at least 2nd	16 <sup>th</sup> c. (2 <sup>nd</sup> half?)	[N] 1,1	1,1 [1/]	Anchor within circle and crowning star similar to Briquet 513 (dated mid sixteenth century) except that the countermark is missing.
S 0604	No, at least 2nd	16 <sup>th</sup> c. (2 <sup>nd</sup> half?)	[1] 2 +	+ 1 [1]	N.k.
S 1793	Probably yes	16 <sup>th</sup> c. (2 <sup>nd</sup> half?)	[1] 3	3 [1]	N.k.
S.A. 0076	No, at least 2nd	16 <sup>th</sup> c. (2 <sup>nd</sup> half?)	[1] 1 +	3 [1]	Bull head same as Briquet 15378 dated in 1523 AD and anchor in circle & crowning star same as Briquet 522 dated 1566 AD.

**Table 33. Endleaves information.**

Catalogue number	Number of sewing Stations	Distance between stations/ Pattern of sewing stations	Accommodation nicks	Sewing thread	Sewing thread thickness	Sewing thread twist	Sewing thread ply	Format of text-block	Number of leaves
S 0216	4	34-74-90-70-31 / B1B2	V-shaped cuts	Linen	Medium	Tight	2Z	4o	273
S 0420	6	17-13-58-68-58-10-20 / C4	V-shaped cuts	Hemp	Medium	Medium	2S	8o	226
S 0604	5	23-67-62-65-65-27 / B1	V-shaped cuts	Hemp	Medium	Loose?	?S	4o	170
S 1793	6	29-12-60-72-62-29-20 / C4B7	N. v.	Linen?	Thin	Medium	?S	4o	272
S.A. 0076	3	38-100-96-40 / B1	V-shaped cuts	Hemp	Medium	Medium	?S	8o	323

**Table 34. Sewing information.**



Catalogue number	Attachment system	Attachment thread	Material	Dimensions	Board edge groove	Spine edge treatment	Spine joints	Boards Thickness	Format of text-block	Thickness of text-block
S 0216	I Uns/1	N.k.	Hardwood	Flush	BG 1	SET 3	Slight	10	4o	75
S 0420	N.v.	N.k.	Hardwood	Flush	BG 1	SET 3	90°	10	8o	70
S 0604	N.v.	N.k.	Wood	Flush	BG 1	SET 3	Slight	10	4o	27
S 1793	I Uns/3c	N.k.	Hardwood	Flush	BG 1	SET 3	120°	12	4o	45
S.A. 0076	I Uns/3c	N.k.	Hardwood	Flush	BG 1	SET 3	Slight	9	8o	84

Table 35. Boards information.

Catalogue number	Spine Lining	Number of layers	Material	Thickness	Board covered	Side of boards covered	Spine shape	Thickness of text-block
S 0216	Yes, all along the spine	1	Canvas	Medium	Not visible	Outside	Flat	75
S 0420	Yes, all along the spine	1	Canvas	Medium	Not visible	Outside	Slight round	70
S 0604	Yes, all along the spine	1	Canvas	Medium	15%	Outside	Round	27
S 1793	Yes, all along the spine	1	Plain textile	Thin	35%	Outside	Slight round	45
S.A. 0076	Yes, all along the spine	1	Canvas	Medium	Not visible	Outside	Flat	84

Table 36. Spine lining information.

Catalogue number	Number of cores	Endband Primary sewing (E. P. S.) type	First core material	Second core material	First core's thickness	Second core's thickness	Distance of projection	Endband's anchoring system	Format of text-block
S 0216	2	Greek double core	Hemp cord	Cord	Medium	Medium	37 mm- 17.4%	EAS 2	4o
S 0420	1	Greek single core?	Cotton cord	-	Thick	-	40 mm- 21.6%	EAS 2	8o
S 0604	2	Greek double core	Wool (?) cord	Cord (wool?)	Medium	Medium	29 mm- 14.2%	EAS 2	4o
S 1793	2	Greek double core	Hemp cord	Cord	Medium	Medium	25 mm- 12.6%	EAS 2	4o
S.A. 0076	2	Greek double core	Hemp cord	Cord	Medium	Medium	37 mm- 17.2%	EAS 2	8o

Table 37. Endband cores information.

Catalogue number	E. P. S. type	Endband secondary weaving (E. S. W.) type	E. P. S. thread	E. P. S. thread thickness	E. P. S. thread twist	P E thread ply	Number of tie-downs	Tie-downs position	Thread anchorage
S 0216	Greek double core	Cretan on single warps	Blue cotton	Medium	Medium	Multiple S	As many as gatherings?	Random	Uses other passing hole outside
S 0420	Greek single core ?	Cretan on single warps	Bleached cotton	Medium	Tight	Multiple S	As many as gatherings?	Centre-fold	Uses change-over station
S 0604	Greek double core	Cretan on single warps	Black and yellow silk plied together	Medium	Tight	Loose?	N.k.	Centre-fold	Uses other passing hole outside
S 1793	Greek double core	Cretan on single warps	Natural linen?	Medium	N.k.	?S	N.k.	N.k	N.v.
S.A. 0076	Greek double core	Cretan on single warps	Natural hemp?	Medium	N.k.	N.k.	As many as gatherings	Centre-fold	N.k.

**Table 38. Endband primary sewing information.**

Catalogue number	E. S. W. type	E. S. W. thread	E. S. W. thread colours	E. S. W. thread thickness	E. S. W. thread ply	E. S. W. thread twist
S 0216	Cretan on single warps	Cotton / Silk	Blue / Yellow, pink	Medium / Thin	Multiple S/Z	Medium / Medium
S 0420	Cretan on single warps	Silk / Silk	Pink / Cyan, pink	Thin / Thin	2S / 2S	Tight
S 0604	Cretan on single warps	Silk / Silk	Cyan / Yellow, pink	Thin / Thin	2S / 2S	Tight
S 1793	Cretan on single warps	Silk / Silk	Pink / Light green, pink	Thin / Thin	2S / 2S	Tight
S.A. 0076	Cretan on single warps	Silk / Silk	Pink / Yellow, pink	Thin / Thin	2S / 2S	Tight

**Table 39. Endband secondary weaving information.**

Catalogue number	Marker	Primary marker	Primary marker material & colour	Primary marker way of attachment
S 0216	Simple	2 plaited strings	1 green & yellow, 1 green & red & white & yellow & blue all silk	FH(a)?
S 0420	Simple	1 ribbon & 1 simple string	Black silk & blue cotton thread	1st sewn on headband with blue cotton thread, 2nd knotted in the middle on the black ribbon
S 0604	None	-	-	-
S 1793	Missing?	-	-	-
S.A. 0076	Simple	2 simple strings	Red silk	Unclear

**Table 40. Markers information.**

Catalogue number	Cover material	Cover colour	Turn-ins type	Turn-ins width	Corner mitre
S 0216	Goat leather	Brown	T-ins 5	Narrow	Co 1
S 0420	Goat leather	Brown	T-ins 3	Medium	Co 1
S 0604	Goat leather	Brown yellow	T-ins 2	Varies	Varies
S 1793	Goat leather	Red-brown	T-ins 3	Narrow	Varies
S.A. 0076	Goat leather	Brown	T-ins 2	Varies	Co 1

**Table 41. Cover information.**

Catalogue number	Left / Right difference?	Covers decoration pattern	Spine decoration pattern	Decoration motives	Number of tools
S 0216	No	Dec2?	Similar to SD4/B	MuF/a16, MuF/b10, MuF/c3, MuF/c49, MuV5, C4	6
S 0420	Yes	Dec3abc (R),	Other(L)	MuF/a16, MuF/b10, MuF/c3, MuF/c33, MuF/d12, MuF/e13, MuA/c3, RoF35(?), C4	9
S 0604	Yes	Dec2abc (R),	Other(L)	MuF/a16, MuF/b10, MuF/c33, MuF/c37, MuF/c49, MuF/d12, MuF/e13, MuA/c3, MuV3, RoF35(?), C4	11
S 1793	No	Declabc	Similar to SD4/B	MuF/a16, MuF/a17, MuF/b10, MuF/c3, MuF/c49, MuF/d11, MuF/d12, MuF/d13, MuF/d14, MuF/e13, MuA/c3, MuV5, C4	13
S.A. 0076	N.k.	Dec3abc(R),	Declabc(L)	MuF/a16, MuF/b10, MuF/c49, MuF/d12, MuF/e13, MuA/c3, RoF 35(?), C4	8

**Table 42. Decoration information**

Tool	Volumes where it is used	Number of volumes where it is used
MuF/a16	All volumes	5
MuF/a17	S. 1793	1
MuF/b10	All volumes	5
MuF/c3	S. 216, S. 420, S. 1793	3
MuF/c33	S. 420, S. 604	2
MuF/c37	S. 604	1
MuF/c49	S. 216, S. 604, S. 1793, S. A. 76	4
MuF/d11	S. 1793	1
MuF/d12	S. 420, S. 604, S. 1793, S. A. 76	4
MuF/d13	S. 1793	1
MuF/d14	S. 1793	1
MuF/e13	S. 420, S. 604, S. 1793, S. A. 76	4
MuA/c3	S. 420, S. 604, S. 1793, S. A. 76	4
MuV3	S. 604	1
MuV5	S. 216, S. 1793	2
RoF35 (?)	S. 420, S. 604, S. A. 76	3
C4	All volumes	5

**Table 43. Tools information**

Catalogue number	Metal furniture type	Number of Furniture	Attachment method	Metal	Format of text-block	Thickness of text-block
S 0216	Bosses, Bas-relief, repousse, engraved plaques	4 L, 4 R	Nailed, ends underneath the Pds	Copper alloy	40	75
S 0420	Bosses	5(-1) L, 5 R	Nailed, ends above the Pds	Copper alloy	80	70
S 0604	Bosses	5 L, 5 R	Nailed, ends flattened above the Pds	Copper alloy	40	27
S 1793	Bosses	5 L, 5 R	Nailed, ends not visible	Lead?	40	45
S.A. 0076	Bas-relief and repousse plaques, bosses	16 L, 5 R	Nailed, ends not visible	Copper alloy	80	84

Table 44. Metal fittings information.

Catalogue number	Number of fastenings	Fastenings type	fastenings material	Fastenings & T-ins arrangement	Strap anchorage type	Ends form	Arrangement of anchorage holes	Metal components
S 0216	0-2-0 ←	Textile straps	Red velvet	None	S Nu. metal fittings	bCAP	N.v.	Anchor plates (M)
S 0420	0-2-0 ←	Three edged leather interlaced straps / Nk	SaC and metal	F & T 1	TBTP	UfaP	AH4	Rings (M) & cast and filed metal compound pins
S 0604	0-2-0 ←	Three edged leather interlaced straps / Nk	SaC and metal	F & T 6	TBP	UfaP	AH4	Rings (M) & cast and filed metal compound pins
S 1793	0-2-0 ←	Three edged leather interlaced straps / Nk	DxC and metal	F & T 1	TBTP	UfaP	AH 4	Rings (M) & pins (M)
S.A. 0076	0-2-0 ←	Three edges silk braided straps.	Red silk and silver threads and metal	F & T 2	TBP	UfaP	AH 4	Rings & cast metal compound pins

Table 45. Fastenings information.

Catalogue number	Text-block edges decoration	Colour	Titling position	Title
S 0216	None	-	-	-
S 0420	Drawn & painted motifs	Black, red, green	Handwritten on head-edge of text-block	KAHMAE
S 0604	None	-	-	-
S 1793	Drawn & painted motifs	Black, red, white	-	-
S.A. 0076	Drawn & painted motifs	Black, red, green	Handwritten on head-edge of text-block inside painted round medallion	Ευαγγέλιον

Table 46. Text-block edges decoration information.

THE GIGLIO BINDINGS

Catalogue Number	Text Chronology	Title	Scribe/s	Format of the text-block	Number of leaves	Notes	Original binding ?
S. 0027	1452	Psalter (T)	Markos Pavlopoulos	8vo (280 x 210)	515 / WP	f. 506 r. «... του γράμαντος σου το παρόν βιβλίον μέμνηται πάντες των κολλών μου σφαλμάτων. Του ταπεινού τε αμαρτωλού και θύτου παπά δε Μάρκου επικλέιν παυλοπούλου. Έλαβε δε τέλος μηνός οκτωβρίου και του έτους τρέχοντος χιλίους τετρακοσίους και πενήκοντα »	No, at least 2nd
S. 0046	14th-15th c.	Psalter (T)	N.k.	8vo (200 x 140)	405/ Par	f. 403 r. There is an ownership note saying that the psalter belonged to Daniel, Proigoumenos of the monastery, followed by the usual courses against anyone who might take the book away from the monastery.	No, at least 2nd
S. 0061	12th c.	Lectuary (L)	N.k.	16mo (150 x 113)	264/ Par		No, at least 2nd
S. 0175	11th-12th c.	Four Gospels (T)	N.k.	8vo (250 x 170)	325/ Par		No, at least 2nd
S. 0361	10th-11th c.	Speeches of St John Chrysostom (T)	N.k.	4to (335 x 260)	194/ Par		No, at least 2nd
S. 0408	1371	Speeches of St. Isaac Syrian (T)	N.k.	8vo (214 x 140)	300/ WP		No, at least 2nd
S. 0448	1004	Paterikon (T)	Leo[...]	4to (330 x 260)	343/ Par	f. 340v. «Ετελειώθη η βιβλος αυτή μηνί ιουνίω ιθ' ημέρα β' νδικτιώνος β' έτους σφι... Γραφείσα δια χειρός Λέο [...] ταπεινού και αμαρτωλού έχασθε δια των θεόν υπέρ του γράμαντος οι αναγιγνώσκοντες».	No, at least 2nd
S. 0500	11th c. (Kamil), 12th-13th (Benesevic)	Meneon (November) (L)	N.k.	4to (380 x 280)	309/ Par	In the left endleaves a parchment document written in the monastery and probably bearing the signature of Ioasaph bears the date 1627	No, at least 2nd
S. 0520	11th c.	Speeches of Saints (T)	N.k.	4to (310 x 233)	294/ Par		No, at least 2nd
S. 0573	1452	Meneon (November) (L)	Manuel Trapezountios	8vo (284 x 210)	295/ WP	In the end: «Ετελειώθη κατά μήνα νομβριον του σσιζ' (6960 AM = 1452 AD) έτους [...] με' γραφέν χειρί μονουήλ ευτελοός ιερέως του τραπεζούντιου».	No, at least 2nd
S. 0585	1453	Meneon (December) (L)	Priest Nicholas of Paraskevas	8vo (275 x 210)	262/ WP	In the end : «Ετελειώθη ο παρόν μήνας δια χειρός εμού νικολάου ευτελοός ιερέως του παρασκευά εν έτει σσιζα' (6961 AM = 1453 AD) Ισπτεβρίω λ'».	No, at least 2nd
S. 0605	15th-16th c.	Meneon (February) (L)	Humble Nikodemos & Priest Petros	4to (295 x 193)	302/ WP	Text-block is composed of two different though closely dated parts, one written by humble Nikodemos (f. 144 v. «Θεός το δώρον ταπεινού νικολήμου κόνος») and the other written by Priest Petros (f. 304 r. : «Θεός το δώρο και πέτρου ιερέως κόνος »)	No, at least 2nd
S. 0615	15th c.	Meneon (March, April) (L)	N.k.	8vo (280 x 200)	336/ WP		No, at least 2nd
S. 0747	15th c.	Tropidion (L)	N.k.	4to (308 x 220)	419/ WP		No, at least 2nd
S. 0763	16th c.	Pentecostanon (L)	N.k.	8vo (280 x 197)	295/ WP		No, at least 2nd
S. 0804	15th c.	Parakletike (L)	N.k.	8vo (280 x 180)	398/ WPP		No, at least 2nd
S. 1048	16th- 17th c.	Liturgy (L)	N.k.	8vo (270 x 195)	123/ WP		No, at least 2nd
S. 1159	17th c.	Speeches of Philotheos (T)	N.k.	8vo (214 x 140)	360/ WP		Yes
S. 1171	16th c.	Kirakodromion (L)	N.k.	8vo (288 x 190)	417/ WP	In the end a note about the close of the monastery by Ioasaph due to the murder of the portaris (the main gate guardian).	No, at least 2nd
S. 1976	1655	Theological Treatises (T)	Joseph	16mo (150 x 100)	398/ WPP	f. 390 r. : «1655 μινή μάλω 26 ιωσήφ». f. 375 r. : «Το παρόν υπάρχη εμού του ταπεινού Ιωσήφ ιερομονάχου σιναιτου του εν κρήτη ..και έγραφα αυτό εν τω αγιατάτω και προφητ/βυρικοτάτω (?) όροι τω σινά. Και ήτις μου [...] ή κόψη το φίλο 1655 μάλω»	Yes
S. A. 0061	1641	Psalter and Odes (T)	Simeon Basam	8vo (210 x 145)	111/ WPP	f. 109 v. : «Το παρόν ψαλτήρι(ον) έγραψεν ο εν ιεροδιακόνιος κυρ σιμεών ο εκ εμέτης πόλε(ως) ο κ(αι) σιναι(ης) και αφιέρωσεν εν τω σινά όρει, ο δε βουλόμ(εν)ος απαλοτριόσαι της μονής, αλλότριος έστω της του Χ(ριστου)δ μήρας κ(αι) έστω αφορισμ(έν)ος και καταραμ(έν)ος κ(αι) ασυγχώρητος κ(αι) μετά θάνατον άλυτος ζυμβ' (7149 AM = 1641 AD) εν μηνί φεβρ(ουαρ)ί(ω) Ο Συναίου Όρους Ιωάσηφ».	Yes
S. A. 0270	1625 or 1639	Various Theological. (T)	Simeon Basam	8vo (208 x 153)	469/ WPP	f. 469 r. : A note written in Arabic similar with the one of the S. A. 337. It is written by Simeon Basam saying that the manuscript was written in 1625 under the service of archbishop Ioasaph. In the end after the signature of Ioasaph there is written in Greek : «εις ζυμβ' (7149 AM = 1639 AD ) κ(α)τα(ά) μήνα φεβρ(ουάρ)ιον».	Yes
S. A. 0325	1639	Teaching and Speeches of St. Theodore Stouditis (T)	N.k.	16mo (153 x 100)	378/ WPP		Yes
S. A. 0337	1622	Speeches of St. John Climax (T)	Simeon Basam	8vo (202 x 152)	306/ WPP	f. 305 r. : A note written in Arabic saying that the manuscript was written by Simeon Basam deacon from Emesa of Syria in 1622 on the 25th of October during the service of Archbishop Ioasaph	Yes
S. A. 0423	1626	Meneon (whole year) (L)	Simeon Basam	4to (307 x 200)	622/ WPP	In the end there is a note with the signature of Ioasaph with the date ζρν(?)β'. The text in Arabic gives the date 7134 AM = 1626 AD 25th of May and the name of the scribe Simeon Basam	Yes
S. A. 0565	1622	Paradise of the Fathers (T)	Simeon Basam	8vo (212 x 140)	474/ WPP	f. 468 v. : A note written in Arabic saying that the manuscript was written by Simeon Basam from Emesa in 1622 AD	Yes

Table 47. Text-block information.

Catalogue Number	Date of Binding	Original binding?	Type of binding	Binder	Binding Note
S 0027	16th c. (1st half) of?	No, at least 2nd	Greek-style	N k	
S 0046	17th c	No, at least 2nd	Greek-style	N k.	
S 0061	17th c (1st half of)	No, at least 2nd	Greek-style	N k.	
S 0175	17th c (1st half of)	No, at least 2nd	Greek-style	N k.	
S. 0361	1632	No, at least 2nd	Greek-style	Anastasios hieromonk	Right flyleaf r.: «ανανέθει ούτος ο εξαήμερος εξ εμού αναστασίου ιερομονάχου επί έτους ζρμ' (7140 AM = 1632 AD) εν μηνί μαίω εν σινάω το αγίο όρος»
S. 0408	1632	No, at least 2nd	Greek-style	Gerasimos hieromonk	f. 13 v.: «Το παρόν μετασταχώθη υπό γερασίμου ιερομονάχου πάνυ φθαρτόν και διασκορπισμένον ετύχανε ον, και μετά μεγάλου κόπου εσυνάγαμεν και αρτιώσαμεν επί έτους ζρμ' (7140 AM = 1632 AD) κατά μήνα ιούνιον»
S. 0448	1637	No, at least 2nd	Greek-style	Klimis	f. 341r.: «Το παρόν κατερικ(όν) ήφερν ο εν ιερομονάχ(οις) κύρ Κλήμης ο κρητός από την ραιθοδ κ(αι) το μεταστάχωσε ότι ήτον κολλ(ή) χαλασμένον επί έτους ζρμ' (7145 AM = 1637 AD) και στελιόθη το στάχωμ(α) ιαννου(α)ρ(ιω) μηνί κ(αι) ωσάν σφαλήθη το μοναστήρι και θέλουν να το πάρουν εκει διά να διαβάζουν συγγωρημένον να το πάρουν Ο σνά όρους Ιωάνναφ»
S. 0500	1632	No, at least 2nd	Greek-style	Gerasimos hierodeacon	Left endleaf v.: «Ο παρόν νοέμβριος μετασταχώθη υπό γερασίμου ιεροδιακόνου εν τω σινάω όρει έτει ζρμ' (7140 AM = 1632 AD) κατά μήνα μάιον.»
S 0520	17th c (1st half of)	No, at least 2nd	Greek-style	N k	
S. 0573	1627	No, at least 2nd	Greek-style	Anastasios hieromonk	Right flyleaf r.: «εσταχώθη το παρόν μηναιο εξ εμού αναστασίου ιερομονάχου επί αίτους ζρλε' (7135 AM = 1627 AD) ιαννουαριου»
S. 0585	1626	No, at least 2nd	Greek-style	Anastasios hieromonk	1 <sup>st</sup> left flyleaf r.: «εσταχώθη το παρών μηναιο εξ εμού αναστασίου ιερομονάχου επί αίτους ζρλε' (7135 AM = 1626 AD) ιαννουαριου»
S. 0605	1639	No, at least 2nd	Greek-style	Klimis	Left endleaf r.: «Το παρόν βιβλίον εσταχώθη υπό χειρός κλήμεντος ιερομονάχου έν έτη ζρμζ' (7147 AM = 1639 AD)»
S 0615	17th c (1st half of)	No, at least 2nd	Greek-style	N k	
S 0747	17th c. (1st half of)	No, at least 2nd	Greek-style	N k	
S. 0763	1636	No, at least 2nd	Greek-style	Sophronios hieromonk from Cyprus	f 293 r.: «Το παρόν πενηκοστόριον μετασταχώθη υπό σωφρονιου ιερομονάχου του κυπρέου με κόπον κολλήν ότι ευρίσκετον διεφθαρμένον πάνυ και είναι του χωρ(ιβ?) επί έτους ζρμδ' (7144 AM = 1636 AD) κατά μην(αν) ιούλιον.»
S. 0804	1627/8	No, at least 2nd	Greek-style	Anastasios hieromonk & monk Makarios	Left endleaf v.: «Το παρόν βηβήλιον εσταχώθη ζρλε' (7153 AM = 1627/8 AD) ηπό χειρός αναστασίου ιερομονάχου και μακαριου μοναχου αχκη'ς.»
S. 1048	1637	No, at least 2nd	Over-size pbs unsupported	Simeon hierodeacon (Basam?)	Right pastedown r.: «Η παρούσα θεία λειτουργία μετασταχώθη υπό του οσιωτάτου ιεροδιακόνου κυρ σιμεών υπό έτους ζρ μ.ε.' (7145 AM = 1637 AD) κατά μήνα ιούλλιο εν τω σινάω αγίω όρει.»
S 1159	17th c. (1st half of)	Yes	Greek-style	N k.	
S. 1171	1632	No, at least 2nd	Greek-style	Simeon hierodeacon (Basam?)	f. 413r.: «Το παρόν θειον και ιερόν ευαγγέλιον μετασταχώθη υπό σιμεών ιεροδιακόνου εν τω σινάω αγίω όρει επί έτους ζρμ' (7140 = 1632) κατά μην(αν) απρίλλιον»
S 1976	1655	Yes	Greek-style	N k	
S A 0061	1641	Yes	Greek-style	N k.	
S. A 0270	1625 or 1639	Yes	Flush pbs unsupported	N k	
S. A 0325	1639	Yes	Projecting pbs unsupported	N k.	
S. A. 0337	1622	Yes	Greek-Islamic binding with flap	N.k.	
S A 0423	1626	Yes	Greek-style	N k	
S A 0565	1622	Yes	Greek-style	N k	

Table 48. Binders information.

Catalogue Number	Original binding	Spine-fold Repairs Type & Material	Text-block Repairs Type & Material
S 0027	No, at least 2nd		
S 0046	No, at least 2nd		
S 0061	No, at least 2nd	Minor repairs with pasted paper strips	
S. 0175	No, at least 2nd		
S. 0361	No, at least 2nd		Missing parts of the text are newly written on rather thick western paper and pasted in fore-edge of leaves Also whole leaves inserted with newly written, missing text.
S. 0408	No, at least 2nd	Most leaves are neatly trimmed along the spine and repaired with paper strips pasted as to turn single, originally conjugate leaves, into bifolia	Whole leaves inserted with newly written missing text.
S 0448	No, at least 2nd	Minor repairs with pasted paper strips Very few overcasting	Paper strips pasted locally
S 0500	No, at least 2nd	Minor repairs with pasted paper strips	Some paper repairs in the leaves of the left end of the text-block
S 0520	No, at least 2nd	Some overcasting	Some paper repairs where parchment is missing Also some sewing of split parchment leaves
S. 0573	No, at least 2nd	Only in first text-block gathering. Paper strips pasted in the front leaf and missing text integrated (see photos)	Very limited. Some pasted paper strips only in leaves of the left end of the text-block.
S 0585	No, at least 2nd	Paper strips pasted locally or all-along the spine-fold of various bifolia	Pasted paper strips in many leaves
S. 0605	No, at least 2nd	Paper strips pasted locally or all-along the spine-fold of various bifolia	
S 0615	No, at least 2nd	Paper strips pasted locally or all-along the spine-folds in the left end gatherings	
S 0747	No, at least 2nd	Paper strips pasted all-along the spine-fold of some gatherings and bifolia.	Paper strips pasted in the corners of some leaves of the right end of the text-block.
S 0763	No, at least 2nd	Minor repairs with pasted paper strips either locally and all-along the spine-folds	Paper strips pasted in many leaves and in some cases missing or covered text written on them
S. 0804	No, at least 2nd	Paper strips pasted locally or all-along the spine-fold of various bifolia	Probably the first eight leaves of the text-block were added in the occasion of the rebinding since they are of the same paper as the endleaves and writing is clearly in a different hand
S. 1048	No, at least 2nd	Many leaves are neatly trimmed along the spine and repaired with Arabic paper Ms waste strips pasted as to turn single, originally conjugate leaves, into bifolia. Also some local minor repairs	
S 1159	Yes		
S. 1171	No, at least 2nd		
S 1976	Yes		
S. A 0061	Yes		
S A 0270	Yes	Ms paper waste strip pasted all-along the spine-fold of the left pastedown.	
S. A 0325	Yes		
S A 0337	Yes		
S A 0423	Yes		
S A 0565	Yes		

Table 49. Repair information.

Catalogue Num.	Original binding?	Left endleaves arrangement	Right endleaves arrangement	Date of Binding
S 0027	No, at least 2nd	{ } 3	?4{ }?	16th c (1st half of?)
S 0046	No, at least 2nd	1 +	+ 3	17th c
S. 0061	No, at least 2nd	1 +	+ 1	17th c (1st half of)
S. 0175	No, at least 2nd			17th c. (1st half of)
S 0361	No, at least 2nd	{ } 1	1{ }	1632
S 0408	No, at least 2nd	{ } 1 +	+{ }	1632
S 0448	No, at least 2nd	{ } 1	1{ }	1637
S 0500	No, at least 2nd	{ } 1 + 2	1{ }	1632
S. 0520	No, at least 2nd	{ } +	+{ }	17th c (1st half of)
S 0573	No, at least 2nd	{ } 3	3{ }	1627
S 0585	No, at least 2nd	{ } 3	3{ }	1626
S 0605	No, at least 2nd	{ } 1	1{ }	1639
S. 0615	No, at least 2nd	{ } 2 +	+ 1{ }	17th c (1st half of)
S. 0747	No, at least 2nd	{ } 3	+ 1{ }	17th c (1st half of)
S 0763	No, at least 2nd	{ }, 1 +?	3{ }	1636
S 0804	No, at least 2nd	{ } 5	3{ }	1627-8
S 1048	No, at least 2nd	{ } 3	3{ }	1637
S 1159	Yes	{ } 3 +	7{ }	17th c (1st half of)
S. 1171	No, at least 2 <sup>nd</sup>	{ } 2 +	+ 2{ }	1632
S. 1976	Yes	{ } 5	7{ }	1655
S. A 0061	Yes	{ } 3	+1{ }	1641
S. A 0270	Yes	{ } +	+{ }	1625 or 1639
S A 0325	Yes	{ } +	+ 2{ }	1639
S. A 0337	Yes	{ } 1 +	+ 1{ }	1622
S A 0423	Yes	{ } 1 +	+ 4{ }	1626
S A 0565	Yes	{ } 3	3{ }	1622

Table 50. Endleaves Information.

Catalogue Num.	Number of sewing stations	Distance between stations / Pattern of sewing stations	Accommodation nicks	Sewing thread	Sewing thread thickness	Sewing thread twist	Sewing thread ply	Format of text-block	Number of leaves
S 0027	4	20-82-80-80-15 / B1	V-shape cuts	Hemp	Medium	Loose	?S	8vo	515
S. 0046	5	21-25-53-51-27-20 / B4B6	V-shape cuts	Waxed hemp	Medium	Medium	2S	8vo	405
S 0061	3	11-57-57-20 / B1	V-shape cuts	Waxed cotton	Thick	Medium	?Z	16mo	264
S 0175	4	25-65-65-65-25 / B1	V-shape cuts	Waxed hemp	Medium	Medium	?S	8vo	325
S 0361	4	38-85-90-85-30 / B1	V-shape cuts	Hemp	Medium	loose	?S	4to	194
S 0408	3	43-60-60-45 / B1	Small V-shape cuts	Hemp	Medium	Medium	2(?) S	8vo	300
S. 0448	5	30-52-70-70-58-48 / B4	V-shape cuts	Cotton	Thick	Loose	3Z	4to	343
S. 0500	5	50-70-65-63-68-70 / A?	V-shape cuts	Hemp	Thick	Medium	?S	4to	309
S. 0520	5	20-65-65-65-67-17 / B1	V-shape cuts	Hemp	Medium	Medium	2S	4to	294
S. 0573	4	35-76-68-70-35 / Other	V-shape cuts?	Hemp	Thin	loose	?S	8vo	295
S 0585	4	43-57-75-72-24 / B1	Not visible	Linen	Medium	Tight	?S	8vo	262
S 0605	4	45-68-64-63-47 / B1	V-shape cuts?	Waxed hemp	Medium	Tight?	?S	4to	302
S. 0615	4	20-77-77-76-28 / B1	V-shape cuts	Hemp	Medium	Medium	?S	8vo	336
S 0747	4	31-80-80-80-35 / B1	V-shape cuts	Waxed hemp	Medium	Loose	2(?) S	4to	419
S. 0763	4	45-65-65-65-40 / B1	Small V-shape cuts	Hemp	Medium	Medium	S	8vo	295
S. 0804	4	30-72-70-65-33 / B1	V-shape cuts	Linen	Medium	Tight	2Z	8vo	398
S. 1048	4	32-59-70-65-40 / B2	Needle holes	Linen	Medium	Medium	Double 10 S	8vo	123
S. 1159	3	26-76-75-34 / B1	V-shape cuts	Blue silk	Medium	Medium	2Z	8vo	360
S 1171	5	43-50-52-50-50-40 / B1A	V-shape cuts	Hemp	Medium	Loose	?S	8vo	417
S. 1976	3	27-41-48-32 / B1	V-shape cuts	Linen	Thin	Medium	2Z	16mo	398
S. A 0061	3	29-74-70-38 / B1	V-shape cuts	Hemp	Medium	Loose	S	8vo	111
S. A 0270	3	30-67-70-37 / B1	Needle holes	Linen	Medium	Medium	2Z	8vo	469
S A 0325	3	18-54-54-26 / B1	Needle holes	Blue, green, red silk	Medium	Medium	2Z	16mo	378
S A 0337	3	42-61-63-36 / B1	Needle holes	Silk	Thin	Loose	2Z	8vo	306
S. A. 0423	4	40-70-67-72-48 / B1	Small V-shape cuts	Red, white silk twisted together	Medium	Loose	2Z	4to	622
S A 0565	3	30-71-70-37 / B1	V-shape cuts	Silk	Thin	Medium	2Z	8vo	474

Table 51. Sewing Information.

Catalogue Number	Attachment system	Material	Dimensions	Boards edge groove	Spine edge treatment	Spine joints	Format of text-block	Thickness of boards	Thickness of text-block
S. 0027	I Uns/13 (L)[V], I Uns/1(R)[V]	Wood	Flush	None	SET 3	120°	8vo	11	95
S 0046	I Uns/4 ?	Hardwood	Flush	None	SET 3	90°	8vo	10	70
S 0061	I Uns/1B	Hardwood	Flush	BG 2	SET 6	45°	16mo	7	50
S 0175	I Uns/1C	Hardwood	Flush	None	SET 4	120°	8vo	10-12	70
S 0361	I Uns/1	Wood	Flush	None	SET 3	120°	4to	10	80
S 0408	I Uns/13 (L), I Uns/1 (R)	Hardwood	Flush	BG 2 (H & T)	SET 3	Slight	8vo	9	57
S. 0448	N v.	Hardwood	Flush	BG 2	SET 3 or SET 4	90°	4to	15	73
S 0500	I Uns/3 (L), I Uns/1 (R)	Wood	Flush	None	SET 7	120°	4to	14	90
S 0520	I Uns/3D	Hardwood	Flush	BG 2	SET 3	Slight	4to	15	85
S 0573	I Uns/1?	Wood	Flush	BG1	SET 3	120°	8vo	10	42
S. 0585	I Uns/1C	Wood	Flush	None	SET 4	120°	8vo	10	41
S 0605	I Uns/3C	Hardwood	Flush	None	SET 2	120°	4to	14	50
S 0615	I Uns/1D	Hardwood	Flush	BG 3	SET 3	90°	8vo	12	48
S 0747	I Uns/3C	Hardwood	Flush	None	SET 4	120°	4to	10	60
S 0763	N v	Hardwood	Flush	BG2 (H & T)	SET 3 or SET 4	120°	8vo	11	53
S 0804	I Uns/1C	Hardwood	Flush	None	SET 4	120°	8vo	11	67
S 1048	II Uns/B1	Pasteboard	Projecting	None	SET 1	None	8vo	3-4	24
S 1159	I Uns/8	Hardwood	Flush	None	SET 4	120°	8vo	9	46
S 1171	I Uns/4?	Wood	Flush	None	SET 7	120°	8vo	10	76
S 1976	I Uns/1D	Hardwood	Flush	None	SET 3	120°	16mo	7	50
S. A 0061	I Uns/1C	Hardwood	Flush	None	SET 2 (L), SET 6 (R)	120°	8vo	9	34
S. A 0270	II Uns/B1	Pasteboard	Flush	None	SET 1	None	8vo	4	65
S. A 0325	II Uns/B1	Pasteboard (E Pap Ms Waste)	Projecting	None	SET 1	None	16mo	3-4	34
S. A 0337	II Uns/B1	Pasteboard	Flush	None	SET 1	None	8vo	3	45
S. A 0423	I Uns/1C (partly I Uns/8)	Hardwood	Flush	None	SET 4	45°	4to	10	80
S. A 0565	I Uns/1B	Hardwood	Flush	None	SET 4	120°	8vo	9	72

Table 52. Boards Information

Catalogue Number	Format of text-block	Spine lining	Material	Thickness	Board covered	Side of boards covered	Spine shape	Thickness of text-block
S 0027	8vo	Yes all along the spine	Canvas	Medium	30%	Outside	Round	95
S 0046	8vo	Yes all along the spine	Cotton (?) canvas	Medium	50%	Outside	Round	70
S 0061	16mo	Yes all along the spine	Red textile	Thin	100%	Outside	Round	50
S. 0175	8vo	Yes all along the spine	N v	Medium	30%	Outside	Round	70
S 0361	4to	Yes all along the spine	Canvas	Medium	50%	Outside	Round	80
S. 0408	8vo	Yes all along the spine	Canvas	Medium	30%	Outside	Round	57
S 0448	4to	Yes all along the spine	Canvas	Thick	25%	Outside	Round	73
S 0500	4to	Yes all along the spine	Canvas	Thin	N v.	Outside	Slight round	90
S 0520	4to	Yes all along the spine	Canvas	Medium	30%	Outside	Slight round	85
S 0573	8vo	Yes all along the spine	Canvas	Thick	35%	Outside	Round	42
S. 0585	8vo	Yes all along the spine	Canvas	Medium?	N v	Outside	Round	41
S. 0605	4to	Yes all along the spine	Canvas	Thin?	N v.	Outside	Round	50
S 0615	8vo	Yes all along the spine	Canvas	Medium	20%	Outside	Round	48
S 0747	4to	Yes all along the spine	Canvas	Medium	20%	Outside	Heavy round	60
S 0763	8vo	Yes all along the spine	Canvas	Thin	30%	Outside	Round	53
S 0804	8vo	Yes all along the spine	N v (Canvas?)	N k	N v	Outside	Heavy round	67
S. 1048	8vo	Yes all along the spine	Canvas	Medium	N v	Outside	Flat	24
S 1159	8vo	Yes all along the spine	N v. (Canvas?)	Medium?	30%	Outside	Round	46
S 1171	8vo	Yes all along the spine	N v (Canvas?)	Medium	35%	Outside	Round	76
S 1976	16mo	Yes all along the spine	Canvas	Medium	50%	Outside	Round	50
S. A 0061	8vo	N v	N v	N k.	N v	Outside?	Round	34
S. A 0270	8vo	Yes all along the spine	Canvas	Medium	N v	Outside	Flat	65
S. A 0325	16mo	Yes all along the spine	Canvas	Medium	N v	Outside	Round	34
S. A 0337	8vo	Yes all along the spine	Leather (SaC)	Medium	25%	Inside	Flat	45
S. A 0423	4to	Yes all along the spine	Canvas	Thin	N v	Outside	Round	80
S. A 0565	8vo	Yes all along the spine	Canvas	Medium?	30%	Outside	Round	72

Table 53. Spine lining information.



Catalogue Number	Number of cores	Endband primary sewing (E. P. S.) Type	First core material	Second core material	Third core material	First core thickness	Second core thickness	Third core thickness	Distance of projection	Text-block format	Endband anchoring system
S. 0027	2	N v.	Cord	Thread	-	Medium	Thin		31mm - (17.1%)	8o	EAS 2 or EAS 3
S. 0046	3	N.v.	Cord?	Thread lengths (S a P E)	Thread	Medium	Thin	Thin	34mm - (25.3%)	8o	EAS 1 or 3
S. 0061	2	Wound plain on 1 <sup>st</sup> core	Cord	Thread	-	Medium	Thin		35mm - (30.4%)	16o	EAS 1?
S. 0175	1	Wound plain on 1 <sup>st</sup> core	Cord		-	Thick			35mm - (20.5%)	8o	EAS 3
S. 0361	2	N.v.	N.v. (silk threads?)	N v.	-	Thick	Medium		27mm - (11.6%)	4o	EAS 3
S. 0408	2	Wound back bead on 1 <sup>st</sup> core	Cord	Thread	-	Medium	Thin		40mm - (28.5%)	8o	N v.
S. 0448	1	Wound plain on 1 <sup>st</sup> core	Cord?	-	-	Thick			32mm - (11.8%)	4o	EAS 2
S. 0500	2	Wound back bead on 1 <sup>st</sup> core (HB) Wound front bead on 1 <sup>st</sup> core (TB)	Cord	Hemp thread	-	Thick	Thin		35mm - (13.7%)	4o	EAS 3
S. 0520	2	Greek double core	Cord	Hemp Cord	-	Thick	Thick		45mm - (19.5%)	4o	EAS 2
S. 0573	2	N v.	Cord?	Cord?	-	Medium	Medium		30mm - (15.7%)	8o	EAS 2
S. 0585	2	N v.	Cord	Thread	-	Medium	Thin		11mm - (5.8%)	8o	EAS 1?
S. 0605	1	N v.	Cord	-	-	Thick			38 mm - (19.1%)	4o	N.v (EAS 2?)
S. 0615	3	N v.	Cord	Cotton Cord	Thread	Medium	Medium	Thin	25mm - (13.5%)	8o	EAS 1
S. 0747	3	N v.	Cord	Cord	Thread	Medium	Medium	Thin	39mm - (20%)	4o	EAS 3
S. 0763	2	N v.	Cord	Thread	-	Medium	Extra thin		32mm - (16.6%)	8o	EAS 2
S. 0804	1	Wound plain on 1 <sup>st</sup> core	Cord	-	-	Medium			27mm - (15.2%)	8o	EAS 1 or EAS 3
S. 1048	2	N v.	Leather (SaC)	Thread?	-	Medium	Thin		N v.	8o	EAS 8
S. 1159	3	N v.	Cord	Cord	Thread	Medium	Medium	Thin	36mm - (26%)	8o	EAS 3
S. 1171	3	N v.	Cord	Cord	Thread	Medium	Medium	Thin	25mm - (13.5%)	8o	N v
S. 1976	2	Wound plain on 1 <sup>st</sup> core	Leather	Thread	-	Thin	Extra thin		30mm - (31.5%)	16o	EAS 3?
S. A. 0061	2	N v.	Cord?	Thread	-	Medium	Extra thin		19mm - (13.3%)	8o	EAS 1
S. A. 0270	2	N v.	Leather	Thread	-	Medium	Thin		A few mm	8o	EAS 6
S. A. 0325	2	N v.	Leather	Thread	-	Medium	Thin		N v.	16o	EAS 8
S. A. 0337	1	Islamic on single warps	Leather	-	-	Thin			None	8o	-
S. A. 0423	3	Wound plain on 1 <sup>st</sup> core	Cord	Cord	Tread	Medium	Medium	Thin	40mm - (20%)	4o	EAS 3
S. A. 0565	3	N v.	Cord	Cord	Thread	Medium	Medium	Thin	40mm - (29.6%)	8o	EAS 1

Table 54. Endband cores information

Catalogue Number	E. P. S. type	E. P. S. thread	E. P. S. thread thickness	E. P. S. thread ply	E. P. S. thread twist	Number of tie-downs	Tie-downs position	Thread anchorage
S. 0027	N v.	Linen	Medium	?S	Medium	As many as gatherings	Centre-fold	Uses change-over station
S. 0046	N v.	Silk	Thin	Double 2S	Tight	As many as gatherings	Centre-fold	Uses change-over station
S. 0061	Wound plain on 1 <sup>st</sup> core	Linen	Medium	4S	Medium	N k.	Centre-fold	Uses change-over station
S. 0175	Wound plain on 1 <sup>st</sup> core	Linen	Thin	?Z	Medium	N k.	Centre-fold	Uses change-over station
S. 0361	N v.	Hemp	Medium	N k.	N k.	N k.	Centre-fold	Uses change-over station
S. 0408	Wound back bead on 1 <sup>st</sup> core	Hemp (SaS)	Medium	2(?) S	Medium	As many as gatherings	Centre-fold	Uses change-over station
S. 0448	Wound plain on 1 <sup>st</sup> core	Cotton	Thick	3Z	Loose	N k.	Centre-fold	Uses change-over station
S. 0500	Wound back bead on 1 <sup>st</sup> core (H) Wound front bead on 1 <sup>st</sup> core (B)	Hemp (Sa.2 <sup>nd</sup> core)	Medium	2S	Medium	As many as gatherings	Centre-fold	Uses other passing hole outside
S. 0520	Greek double core	Hemp (SaS)	Medium	?S	Loose	N k.	Centre-fold	Uses other passing hole outside
S. 0573	N v.	Hemp	Medium	?S	Loose	N k.	Centre-fold	Uses change-over station
S. 0585	N v.	Linen	Medium	?S	Tight	N k.	Centre-fold	Uses change-over station
S. 0605	N v.	Waxed(?) Linen (SaS)	Medium	?S	Tight?	N k.	Centre-fold	Uses change-over station
S. 0615	N v.	Linen	Thin	2S	medium	As many as gatherings	Centre-fold	Uses change-over station
S. 0747	N v.	Waxed Linen	Medium	?S	Tight?	N k.	Centre-fold	Uses change-over station
S. 0763	N v.	Linen	Thin	2S	Medium	N k.	Centre-fold	Uses other passing hole outside
S. 0804	Wound plain on 1 <sup>st</sup> core	Linen (SaS)	Medium	2Z	Tight	N k.	Centre-fold	Uses change-over station
S. 1048	N v.	Linen (SaS)	Medium	10S	Medium	N k.	Centre-fold	Uses change-over station
S. 1159	N v.	Waxed (?) Linen	Medium	?Z?	N k.	As many as gatherings	Centre-fold	Uses change-over station
S. 1171	N v.	Linen	Medium	?S	Loose?	N k.	Centre-fold	Uses change-over station
S. 1976	Wound plain on 1 <sup>st</sup> core	Linen	Thin	2 2S	Medium	As many as gatherings	Centre-fold	Uses change-over station
S. A. 0061	N v.	Linen	Medium	Z	Loose	N k.	Centre-fold	Uses change-over station
S. A. 0270	N v.	Linen	Medium	Z	Loose	N k.	Centre-fold	Uses change-over station
S. A. 0325	N v.	Linen	Medium	?S	Medium	As many as gatherings	Centre-fold	Uses change-over station
S. A. 0337	Islamic on single warps	Red, white silk / Linen	Thin / Medium	2S / 3S	Tight / Medium	N.k.	Centre-fold	Uses change-over station
S. A. 0423	Wound plain on 1 <sup>st</sup> core	Cotton?	Medium	Multiple S	Tight?	As many as gatherings	Centre-fold	Uses change-over station
S. A. 0565	N v.	Linen	Medium	?S	Medium	As many as gatherings	Centre-fold	Uses change-over station

Table 55. Endband primary sewing information.

Catalogue Number	Endband secondary sewing / weaving (E. S. S. / W.) type	E. S. S. / W. thread colours	E. S. S. / W. thread	E. S. S. / W. thread thickness	E. S. S. / W. thread ply	E. S. S. / W. thread twist
S 0027	Embroidered, front bead & crowning core (2 colours)	Green, red	Silk	Medium	?Z?	Loose
S 0046	3-core Chevron & crowning core (3 colours)	Green (2 hues), white	Silk	Thin	2S	Tight
S 0061	Embroidered, front bead & crowning core (2 colours)	Red, white	Silk	Thin	2S	Tight
S 0175	Embroidered, front bead (2 colours)	Blue, white	Silk?	Thin	2S	Tight
S 0361	Greek double core (3 colours)	Blue, yellow, red	Silk	Medium or thick?	2(?)Z	Loose?
S 0408	2-core Chevron & crowning core (2 colours)	Yellow, red	Silk (probably 2 different types)	Thin	2(?) Z	Loose?
S 0448	Embroidered, front bead (2 colours)	Green, red	Silk	Medium	Z?	Loose
S 0500	Embroidered, front bead & crowning core (2 colours)[HB], 2-core Chevron & crowning core (4 colours) [TB]	Green, red (H), Blue, green, red, white, (T)	Silk	Medium	multiple 1	Loose
S 0520	None	-	-	-	-	-
S 0573	2-core Chevron & crowning core (4 colours)	Green, red, pink, white	Silk	Medium	2Z	Loose
S 0585	2-core Chevron & crowning core (4 colours)	Green, red, pink, white	Silk	Medium	2Z	Tight
S 0605	Embroidered, front bead (2 colours)	Green, red	Silk	Thin	Nk	Loose
S 0615	3-core Chevron & crowning core (3 colours)	Green (light), pink, white	Silk	Thin	2S	Medium
S 0747	3-core Chevron & crowning core (3 colours)	Green, yellow, red	Silk	Medium	2Z	medium
S 0763	Embroidered, front bead & crowning core (2 colours)	Red, white	Silk	Extra thin, Medium	S	Tight
S 0804	Embroidered, front bead (2 colours)(same as S 605)	Green, red	Silk	Thin	Loose	Nk
S 1048	Embroidered, front bead & crowning core (2 colours)	Red, white	Silk	Medium	Z	Medium
S 1159	3-core Chevron & crowning core (4 colours)	Blue, green, yellow, red	Silk	Medium	2Z	Tight
S 1171	3-core Chevron & crowning core (4 colours)	Blue, green, yellow, red	Silk	Medium	2Z	Loose
S 1976	Only vestiges [Embroidered, front bead & crowning core (2 colours)]	Red, white	Silk	Thin	N k.	N k.
S A 0061	Embroidered, front bead & crowning core (2 colours)	Red, white	Silk	Thin	S	Medium
S A 0270	Embroidered, front bead & crowning core (3 colours)	Cyan, yellow, red	Silk	Thin	Z	Loose
S. A. 0325	Embroidered, front bead & crowning core (3 colours)	Green (light), yellow, red	Silk	Medium	2Z	Medium
S. A 0337	None	-	-	-	-	-
S A 0423	3-core Chevron & crowning core (4 colours)	Blue, green, yellow, red,	Silk	Medium	2Z	Loose
S A 0565	3-core Chevron & crowning core (4 colours)	Blue, green, yellow, red	Silk	Medium	2Z	Medium

Table 56. Endband secondary sewing / weaving information

Catalogue Number	Marker	Primary marker	Primary marker material & colour	Primary M way of attachment	Secondary marker	Secondary marker material & colour	Secondary M way of attachment
S. 0027	None	-	-	-	-	-	-
S. 0046	Compound	1 Compound closed loop F (1 colour)	Cord core & pink silk	FH(c)	1 single colour thread string	Unidentified white thread (vestiges)	KiM?
S. 0061	Compound	1 Simple open loop (2 colours)	Multiple white & red silk threads (SaE)	FH(c)	1 single colour thread string	Red silk (S.a.E.)	L
S. 0175	Compound	1 Compound closed loop F (1 colour)	Cord core & pink silk	FH(c)	Missing	-	-
S. 0361	Compound	1 Compound closed loop E (1 colour)	Cord core & green silk	FH(c)	1 two-colours thread string	2 strings, each made of yellow, red silk (S.a.E.) threads, twisted together	Unclear
S. 0408	Compound	1 Simple kinked open loop (2 colours)	Multiple yellow & red silk threads (SaE).	FH(c)	1 two-colours thread string	Red & yellow silk (S.a.E.) thread twisted together	KiM
S 0448	None	-	-	-	-	-	-
S 0500	None	-	-	-	-	-	-
S 0520	None	-	-	-	-	-	-
S 0573	Compound	1 Simple open loop (1 colour)	2 green silk threads (SaE)	FH(c)	Missing	-	-
S 0585	Compound	1 Simple open loop (1 colour)	2 green silk threads (SaE).	FH(c)	Missing	-	-
S. 0605	Compound	1 Simple kinked open loop (2 colours)	2 threads, each made of green & red silk (SaE)	FH(c)	2 single colour thread strings	1 of red, and 1 of orange silk thread (p S a E)	KiE
S. 0615	Compound	1 Compound closed loop F (1 colour)	Cord core & green silk (SaE).	FH(c)	1 three-colours thread string	Each made of blue cotton(?), white & yellow silk threads, twisted together	KiM
S. 0747	Compound	1 Simple closed loop (3 colours)	2 threads, each made of green, red & yellow silk (SaE)	FH(c)	Missing	-	-
S. 0763	Compound	2 Simple kinked closed loops (2 colours)	2 threads, each made of white & red silk (SaE)	FH(c)	1 two-colours thread string	White & red silk (S.a.E.) threads twisted together	L
S 0804	None	-	-	-	-	-	-
S. 1048	Compound	1 Simple kinked open loop (2 colours)	Multiple white & red silk threads (SaE).	FH(c)	1 two-colours thread string and tassel	White & red silk (S.a.E.) threads plaited. Tassel made with red silk and silver around silk	Pla
S. 1159	Compound	1 Simple kinked open loop (1 colour)	4 yellow silk threads(SaE).	FH(c)	Missing	-	-
S. 1171	Compound	1 Simple kinked open loop (1 colour)	4 yellow silk threads (SaE).	FH(c)	1 single colour thread string	Plaited fade blue cotton (?)	S
S. 1976	None (Missing?)	-	-	-	-	-	-
S. A. 0061	Compound	1 Simple kinked open loop (2 colours)	Multiple white & red silk threads (SaE)	FH(c)	Missing	-	-
S. A. 0270	None	-	None	-	-	-	-
S. A. 0325	Compound	1 Simple open loop (2 colours)	2 (?) red & green silk threads	FH(c)	1 single colour thread string	Whitish cotton(?)	KiE
S A 0337	None	-	-	-	-	-	-
S. A. 0423	Compound	1 Unspecified simple closed loop- vestiges (1 colour)	? red silk threads (SaE).	FH(c)	Missing	-	-
S. A. 0565	Compound	1 Unspecified simple open loop (1 colour)	? green silk (SaE) threads	FH(c)	Missing	-	-

Table 57. Markers information

Catalogue Number	Cover material	Cover colour	Turn-ins type	Turn-ins width	Corner mitre	Edge tongued extensions
S 0027	Goat leather	Yellow-brown	T-ins 3	Vanes	Vanes	None
S 0046	Goat leather	Yellow-brown	T-ins 5	Narrow	Co 1	None
S 0061	Goat leather	Yellow-brown	T-ins 5	Medium	Co 7, Co 4	From fore edge to head and tail edges, external
S 0175	Sheep? leather	Red-brown	T-ins 5	Vanes	Vanes	None
S 0361	Goat ? leather	Black	T-ins 2	Medium	Co 1	None
S 0408	Goat leather	Yellow-brown	T-ins 1, T-ins 3	Vanes	Vanes	None
S 0448	Goat ? leather	Yellow-brown	T-ins 3	Medium	Vanes	None
S 0500	Goat ? leather	Black	T-ins 1, T-ins 3	Vanes	Co 1, Co 6	None
S 0520	Sheep ? leather	Yellow-brown	T-ins 3	Wide	Co 6	None
S 0573	Goat leather	Yellow-brown	T-ins 3	Vanes	Co 2	From fore edge to head and tail edges, external
S 0585	Goat leather	Brown	T-ins 6	Wide	Co 2 Co 13	None
S 0605	Goat leather	Yellow-brown	T-ins 3	Wide	Co 2	None
S 0615	Goat ? leather	Yellow-brown	T-ins 2	Narrow	Co 1, Co 7	None
S 0747	Goat leather	Black	T-ins 3	Medium	Co 2	None
S 0763	Goat ? leather	Brown	T-ins 3	Medium	Co 2, Co 3	None
S 0804	Sheep leather	Yellow-brown	T-ins 3	Wide	Co 5, Co 6	None
S 1048	Camel ? leather	Yellow-brown	T-ins 2	Medium	Co 2?	None
S 1159	Sheep leather	Yellow-brown (dark)	T-ins 3	Wide	Co 1	None
S 1171	Goat leather	Yellow-brown	T-ins 3	Vanes	Co 13	None
S 1976	Goat ? leather	Brown	T-ins 3	Medium	Co 4, Co 5	None
S A 0061	Goat leather	Yellow-brown	T-ins 3	Vanes	Co 1	From fore edge to head and tail edges, external
S A 0270	Goat ? leather	Red	T-ins 3	Medium	Co 2	None
S A 0325	Goat leather	Brown	T-ins 3	Vanes	Co 9, Co 12	None
S A 0337	Goat ? leather	Light Brown	T-ins 3	Narrow	Co 2, Co 3	None
S A 0423	Sheep ? leather	Black	T-ins 3	Wide	Co 2	None
S A 0565	Goat leather	Yellow-brown	T-ins 3	Medium	Co 2, Co 3	None

Table 58. Cover Information

Catalogue Number	Left / Right difference?	Decoration pattern	Spine decoration pattern	Board edges decoration pattern	Decoration tool	Number of tools
S 0027	No	Dec11a	None	None	MuF/c1, MuV3, MuV4, RoF43, C6	5
S 0046	No	Dec1a	SD5/B	BED 6	MuF/c1, MuV3, MuV4, RoF10, C5	5
S 0061	No	Dec1a	None	None	MuF/c1, MuA/b4, MuV4, filets	4
S 0175	Yes	Dec2a	None	None	MuF/c1, RoF10, C5	3
S 0361	No	Dec2	None	None	MuF/c1, MuV4, C6	3
S 0408	No	Dec2a	SD2/B	None	MuF/c1, MuA/b4, MuV4, C5	4
S 0448	No	Dec2a	None	None	MuF/c1, RoF43(?), C5	3
S 0500	No	Declabcd	SD2/B	BED5	MuF/c1, MuA/b4, MuV3, CeR4, RoF43(?), C6	6
S 0520	Yes	Dec3a(R), Other(L)	Nk (missing)	None	MuF/c1, MuA/b4 (?), MuG/b3, MuV4, C7	5
S 0573	No	Dec1a	Nk (covered)	None	MuF/c1, MuG/b3, MuV4, C7	4
S 0585	No	Dec2a	None	None	MuV4, RoF43, C7	3
S 0605	No	Dec2a	None	None	MuF/c1, MuG/b3, MuV4, C5	4
S 0615	No	Declabc	None	None	MuF/c1, MuV3, MuV4, RoF10, RoF37, C6	6
S 0747	No	Dec2a	SD2/B	None	MuF/c1, MuG/b3, MuV4, C7	4
S 0763	No	Dec1a	None	None	MuF/c1, MuF/d4, MuV3, MuV4, C6	5
S 0804	No	Dec2	None	None	MuF/c1, MuV4, C6	3
S 1048	No	Dec1a	None	None	MuF/c1, MuG/b3, MuV4, C5	4
S 1159	No	Dec1a	SD2/B	None	MuF/c1, MuA/b4, MuV4, C7	4
S 1171	No	Dec1a	None	None	MuF/c1, MuF/d4, MuV4, C7	4
S 1976	No	Dec1a	SD2/B	None	MuF/c1, MuA/b4, MuV4, C7	4
S A 0061	No	Dec1a	None	None	MuF/c1, MuG/b3, MuV4, C7	4
S A 0270	No	Dec1a	None	None	MuF/c1, MuA/b4, MuV4, C7	4
S A 0325	No	Dec1a	None	None	MuF/c1, MuG/b3, MuV4, C7	4
S A 0337	No	Dec1a	None ?	None	MuF/c1, MuA/b4, MuV4, filets	4
S A 0423	No	Dec1a	None	None	MuF/c1, MuG/b3, MuV4, C7	4
S A 0565	No	Dec1a	None	None	MuF/c1, MuA/b4, MuV4, C7	4

Table 59. Decoration Information

Tool	Volumes in which the tool is used	Number of Volumes where it is used
MuF/cl	All volumes except S 585	25
MuV4	All volumes except S 175, S 448, S 500	23
MuA/b4	S 61, S. 408, S 500, S 520, S 1159, S 1976, S A 270, S A 337, S A 565	9
MuG/b3	S 520, S 573, S 605, S 747, S 1048, S A 61, S A 325, S A 423	8
MuV3	S 27, S 46, S 500, S 615, S 763	5
RoF43	S 27, S. 448(?), S 500(?), S 585	4
RoF10	S 46, S 175, S 615	3
MuF/d4	S. 763, S 1171	2
RoF37	S 615	1
CeR4	S. 500	1
C5	S 46, S. 175, S. 408, S 448, S 605, S 1048	6
C6	S 27, S 361, S 500, S 615, S 763, S 804	6
C7	S. 573, S 585, S 747, S 1159, S 1171, S 1976, S A 61, S A 270, S A. 325, S A. 423, S A 565	11
Filets	S 61, S A 337	2

Table 60. Tools information

Catalogue Num.	Metal furniture type	Number of Furniture	Attachment method	Metal	Format of text-block	Thickness of text-block
S 0027	Bosses	4 (-1) L, 4 (-3) R	Nailed, ends underneath the pbs	Copper alloy	8vo	95
S. 0046	None				8vo	70
S 0061	Bosses	5 (-4) L, 5 (-1) R	Nailed, ends flattened above the t-ins	Lead?	16mo	50
S. 0175	Bosses & engraved cross	5 (-1) L, 5 (-1) R	Nailed, only ends of the cross nails flattened in the inside of the Bds	Copper alloy	8vo	70
S 0361	None				4to	80
S 0408	None				8vo	57
S 0448	None				4to	73
S 0500	No				4to	90
S 0520	Bosses	5 (-4) L, 5 (-4) R	Nailed, ends underneath the pbs	Copper alloy	4to	85
S. 0573	Bosses	4 L, 4 R	Nailed, ends underneath the pbs	Copper alloy	8vo	42
S 0585	Bosses	4 L, 4 R	N v.	N k	8vo	41
S 0605	None				4to	50
S. 0615	Bosses	5 L, 5 R	Nailed, ends flattened above the pbs	Copper alloy	8vo	48
S 0747	None				4to	60
S 0763	None				8vo	53
S 0804	None				8vo	67
S. 1048	None				8vo	24
S. 1159	None				8vo	46
S. 1171	None				8vo	76
S. 1976	None				16mo	50
S A 0061	None				8vo	34
S A 0270	None				8vo	65
S. A 0325	None				16mo	34
S. A 0337	None				8vo	45
S. A. 0423	None				4to	80
S A 0565	None				8vo	72

Table 61. Metal fittings information

Catalogue Number	Edges decoration	Colour/s
S 0027	Painted homogeneously (after endbanding)	Red
S 0046	None	
S 0061	None	
S 0175	None	
S 0361	None	
S 0408	None	
S 0448	None	
S. 0500	Drawn and painted motives	Black, olive green, red
S. 0520	None	
S. 0573	Painted homogeneously	Green
S 0585	Painted homogeneously (after endbanding and covering)	Green
S 0605	None	
S 0615	None	
S. 0747	None	
S. 0763	None	
S 0804	None	
S. 1048	None	
S. 1159	Drawn and painted motives	Black, olive green
S 1171	None	
S 1976	None	
S A 0061	None	
S A 0270	None	
S A 0325	None	
S A 0337	None	
S. A. 0423	None	
S A 0565	None	

Table 62. Text-block edges decoration information.

Catalogue Number	Number of fastenings	Fastenings type	Fastenings material	Strap anchorage type	Fastenings & T-ins arrangement	Ends form	Arrangement of anchorage holes	Format of text-block	Thickness of text-block	Metal components
S. 0027	0-2-0 ←	Three edged leather interlaced straps / N k.	DtC, metal	TBT	F & T 1	UuP	AH 4	8vo	95	Rings (M) & cast and filed metal compound pins
S. 0046	0-1-0 ←	Three edged leather interlaced strap / long hinge	SaC, metal	TB	F & T 6	Ufi.	AH 4	8vo	70	Ring & cast metal compound pin
S. 0061	0-1-0 ←	Uncertain three edged strap ? (M)	N.k.	TB	F & T 6	N.k. (M)	AH 4	16mo	50	Ring (M) & cast compound metal pin
S 0175	0-1-0 ←	Three edged leather interlaced strap / N k.	SaC, metal	TB	F & T 2	UpaP	AH 4	8vo	70	Ring (M) & filed simple metal pin
S. 0361	0-2-0 ←	Three edged leather interlaced straps / N k	DtC, metal	TBT	Nk	UuP	AH 4	4to	80	Rings (M) & cast metal compound pins
S. 0408	0-2-0 ←	Three edged silk braided straps	Silk and metal	TBTP	F & T 1	UfaP	AH 4	8vo	57	Rings & cast metal compound pins
S. 0448	0-1-0 ←	Uncertain three edged straps ? (M)	N.k.	TBTP	F & T 1	N.k. (M)	AH 4	4to	73	Ring (M) & filed simple metal pin
S. 0500	0-2-0 ←	Three edged leather interlaced straps / N k	SaC, metal	TBTP	F & T 8	1UfaP, 1TbPpPC	AH 4	4to	90	Rings (M) & cast metal compound pins
S. 0520	0-2-0 ←	Three edged leather interlaced strap / N k	SaC, metal	TBT	F & T 1	UuP	AH 4	4to	85	Rings (M) & cast metal compound pins
S. 0573	0-2-0 ←	Two edged leather interlaced straps / N.k. Originally uncertain three edged straps (M)	DtC, metal	TBTP	F & T 1	UbPpPC	AH 4	8vo	42	Rings (M) & cast metal compound pins
S. 0585	0-2-0 ←	Three edged leather interlaced straps / N k	1 SaC, 1 DtC, metal	TBT	F & T 1	UpaP	AH 4	8vo	41	Rings (M) & cast metal compound pins
S. 0605	0-2-0 ←	Three edged leather interlaced straps / long hinge	SaC, metal	TBTP	F & T 2	TfaP	AH 4	4to	50	Rings (PM) & cast and filed metal compound pins
S. 0615	0-2-0 ←	Three edged leather interlaced straps / long hinge	SaC, metal	TBT	F & T 6	UfaP	AH 4	8vo	48	Rings (PM) & cast metal compound pins
S. 0747	0-2-0 ←	Three edged leather interlaced straps / long hinge	SaC, metal	TBTP	F & T 2	UfaP	AH 4	4to	60	Rings & cast metal compound pins
S. 0763	0-2-0 ←	Three edged leather interlaced straps / standard	DtC, metal	TBTP	F & T 1	UbPpPC	AH 4	8vo	53	Rings (PM) & cast and filed metal compound pins
S. 0804	0-1-0 ←	Three edged leather interlaced strap / N k	N.k.	TBT	F & T 1	UuP	AH 4	8vo	67	Ring (M) & cast metal compound pin
S 1048	0-2-0 →→	Leather ties	SaC	TBTP	F & T 1	TfaP	AH 5	8vo	24	None
S. 1159	0-2-0 ←	Three edged leather interlaced straps / long hinge	SaC, metal	TBT	F & T 1	UuP	AH 4	8vo	46	Rings (PM) & cast metal compound pins
S. 1171	0-2-0 ←	Hook and catch plate Originally uncertain three edged straps (M)	DtC, metal	NuCl Original N k.	F & T 1	bCB	Originally AH 4	8vo	76	Catch plate, anchor plate, hook (M)
S. 1976	0-1-0 ←	Uncertain three edged strap ? (M)	N.k.	TB	F & T 6	N.k. (M)	AH 4	16mo	50	Ring (M) & filed metal simple pin
S. A. 0061	0-1-0 ←	Three edged leather interlaced strap / long hinge	SaC, metal	TBT	F & T 2	UfaP	AH 4	8vo	34	Ring & cast metal compound pin
S A 0270	0-2-0 →→	Leather ties	DtC	TBTP	F & T 2	TbPpPC	AH 5	8vo	65	None
S A 0325	0-2-0 →→	Leather ties	N k.	TBTP	F & T 1	TfaP	AH 5	16mo	34	None
S. A. 0337		None	-	-	-	-	-	8vo	45	-
S. A. 0423	0-2-0 ←	Uncertain three edged straps ? (M)	N.k.	TBTP	F & T 1	UpaP (?)	AH 4	4to	80	Rings (M) & cast metal compound pins (PM)
S. A. 0565	0-2-0 →	Three edged leather interlaced straps / N k	SaC, metal	TBTP	F & T 6	N.k. (M)	AH 4	8vo	72	Rings (M) & cast metal compound pins

Table 63. fastenings information.

## THE CAIRO METOCHION BINDINGS

Catalogue Number	Text chronology	Title	Scribe	Format of text-block	Number of leaves	Notes	Original binding?
S. 0356	10th c.	Homilies of St. John Chysostomos (T)	Nk	4vo (342 x 240)	298 Par		No, at least 2nd
S. 0574	1465	Menaion (November) (L)	Nikolaos Skouras	8vo (274 x 195)	245 WpP	f. 240 r. : «Ετελειώθει το παρόνμνημαον δια συνδρομής και εξόδο του πανοσιωτάτου εν μοναχοίς κυρίου Αθανασίου και οικονόμου της αγίας και σεβασμίας μονής του Σνά όρους εγράφη δε δια χειρός καμού του αμαθούς αμαρτωλού νικολάου του σκούρα του μετονομασθέντος παρά των κρητών(?) αμπελοκλάδης(?) και οι εν τυχάνον αυτό εχχεσθένμοι δια τον κύριον υπέρ των αμέτερτων μου σφαλιμάτων. Εγράφη εν έτει στ σγ' (6973 AM = 1465 AD) η' κατά μήνα μάρτιο κς' .»	No, at least 2nd
S. 2002	17th? c. (Kamil dates it in the 18th)	Psalter (T)	Nk	16mo (157 x 108)	144 WpP		Yes
S. A. 0351	1635/1641 & 13th c.	Homilies of St. Isaac the Syrian (T)	Simeon Basam	8vo (210 x 152)	379 WpP, EP	There is a note in Arabic bearing a date in Greek ζρηθ' (7149 AM = 1641 AD) followed by the signature of Ioasaph. The Arabic text gives the date 7143 AM = 1635 AD) and the scribe as Simeon Basam from Emesa.	Partly

Table 64. Text-block information.

Catalogue Number	Date of Binding	Original binding?	Type of binding	Note	Binder
S. 0356	1633	No, at least 2nd	Greek-style	Right flyleaf r. : «Τω ζρηα (7141 AM = 1633 AD) κατά μηη(αν) μάιον ο παρόν ηζαήμερος εμετασταχώθι υπο σωφρονίου ιεροδ(ιακόνου) του κυρέου εν μετοχίω της αγύπτου.» Left flyleaf v. : «Και επίρα εγώ κλήμης ιεροδιάκονος αυτό το χαρτή νοεμβρίου ια' .»	Sophonios Hieromonk from Cyprus
S. 0574	17th c.	No, at least 2nd	Greek-style	-	N.k.
S. 2002	17th c. (1 <sup>st</sup> half)	Yes	Oversize pasteboard binding with supports	-	N.k.
S. A. 0351	1635-41	Partly	Oversize pasteboard binding with supports	-	Simeon Basam?

Table 65. Binders information

Catalogue Number	Original binding?	Spine-fold repair Type/Material	Text-block Repair Material
S. 0356	No, at least 2nd	Minor repair with western paper strips pasted locally in the spine-folds.	Minor repairs with western paper.
S. 0574	No, at least 2nd	Minor repair with western paper Ms waste strips pasted locally and all along the spine-folds.	Minor repairs with western paper.
S. 2002	Yes	-	
S. A. 0351	Partly	Very few western paper strips pasted all along the spine-folds	ff. 192-201, originally of a smaller format, framed with western paper pasted all around to fit the bigger format of the rest of the text-block.

Table 66. Repair information.

Catalogue Number	Original binding ?	Left endleaves arrangement	Right endleaves arrangement
S. 0356	No, at least 2nd	[1] 3	3 [1]
S. 0574	No, at least 2nd	2	4
S. 2002	Yes	[1] 1 +	+ 1 [1]
S. A. 0351	Partly	[1] 3 + 2+	+3 + 3 [1]

Table 67. Endleaves information.

Catalogue Number	Number of sewing stations	Distance between stations / Pattern of sewing stations	Accommodation nicks	Number of supports	Thickness of supports	Supports material	Format of text-block	Number of leaves
S. 0356	5	30-70-62-74-68-33 / B4?	V-shape cuts	-	-	-	4to	298
S. 0574	5	22-55-60-60-60-25 / B1	V-shape cuts	-	-	-	8vo	245
S. 2002	5	17-17-46-43-18-16 / B6	Needle holes	1-1-1	Thin	Parchment strip twisted?	16mo	144
S. A. 0351	5	17-20-71-60-24-20 / B6?	Needle holes	1-1-1	Medium	Leather thong flat	8vo	379

Table 68. Sewing information

Catalogue Number	Sewing thread	Sewing thread thickness	Sewing thread twist	Sewing thread ply
S. 0356	Hemp	Thick	Medium	S
S. 0574	Hemp	Medium	Loose	S
S. 2002	Linen	Thin	Medium	2S
S. A. 0351	Cotton?	Medium	Tight	?S

Table 69. Sewing thread information

Catalogue Number	Attachment system	Material	Dimensions	Board edge groove	Spine edge treatment	Spine joints	Format of text-block	Thickness of boards	Thickness of text-block
S. 0356	I Uns/ I D	Hardwood	Flush	None	SET 3 or SET 4	120°	4to	13	80
S. 0574	I Uns/ 3	Hardwood	Flush	BG2 (HE & TE only)	SET 3 or SET 4	120°	8vo	11	40
S. 2002	II Uns/ AI	Pasteboard	Projecting	None	SET 1	None	16mo	3-4	20
S. A. 0351	Sup 4	Pasteboard	Projecting	None	SET 1	None	8vo	3	56

Table 70. Boards information

Catalogue Number	Spine lining	Material	Thickness	Board covered	Side of boards covered	Spine shape	Thickness of text-block
S. 0356	Yes all along the spine	Canvas	Thin	30%	Outside	Heavy round	80
S. 0574	Yes all along the spine	Canvas?	N.k.	25%	Outside	Round	40
S. 2002	Yes, between the sewing stations	Canvas	Medium	N.v.	Outside	Slight round	20
S. A. 0351	Yes, between the sewing stations	Canvas	Medium	30%	Outside	Round	56

Table 71. Spine lining information.

Catalogue Number	Number of cores	Endband primary sewing (E. P. S.) type	First core material	Second core material	First core thickness	Second core thickness	Distance of projection	Format of text-block	Endband anchoring system
S. 0356	2	Wound plain on 1st core?	Cord	Thread	Thick	Extra thin	55mm - 25.5%	4to	EAS 1
S. 0574	1	N.v.	Cord?	-	Medium	-	32mm - 33.9%	8vo	EAS 1
S. 2002	2	Wound plain on 1st core?	Leather	Thread	Medium	Thin	None	16mo	None
S. A. 0351	2	Wound plain on 1st core?	Leather	Thread	Medium	Thin	N.k.	8vo	EAS 8

Table 72. Endband cores information.

Catalogue Number	E. P. S. type	Endband secondary sewing (E. S. S.) type	E. P. S. sewing thread	E. P. S. thread thickness	E. P. S. thread twist	E. P. S. thread ply	Number of tie-downs	Tie-downs position	Thread anchorage
S. 0356	Wound plain on 1st core?	Embroidered, front bead & crowning core (3 colours)	Cotton?	Medium	Tight	S	N.k.	Random	Uses change-over station
S. 0574	N.v.	Embroidered, front bead (2 colours)	Hemp	Thin	Medium	?S	N.k.	Centre-fold	Uses other passing hole above
S. 2002	Wound plain on 1st core?	Embroidered, front bead & crowning core (2 colours)	Linen (SaS)	Thin	Medium	2S	As many as gatherings	Centre-fold	Uses change-over station
S. A. 0351	Wound plain on 1st core?	Embroidered, front bead & crowning core (2 colours)	Cotton?(SaS)	Medium	Tight	?S	As many as gatherings	Centre-fold	Uses change-over station

Table 73. Endband primary sewing information.

Catalogue Number	E. S. S. type	E. S. S. thread colours	E. S. S. thread	E. S. S. thread thickness	E. S. S. thread ply	E. S. S. thread twist
S. 0356	Embroidered, front bead & crowning core (3 colours)	Red, Green, Yellow, Red	Silk	Thin	?S	Loose
S. 0574	Embroidered, front bead (2 colours)	Green, White	Silk	Thin	?S	Loose
S. 2002	Embroidered, front bead & crowning core (2 colours)	Pink, White	Silk	Thin	?I?	Loose
S. A. 0351	Embroidered, front bead & crowning core (2 colours)	Red (bright), Yellow	Silk	Medium	2Z	Loose

Table 74. Endband secondary sewing information.

Catalogue Number	Cover material	Cover colour	Turn-ins type	Turn-ins width	Corners mitre
S. 0356	Goat? leather	Yellow-brown	T-ins 2	Varies	Co 1
S. 0574	Goat? leather	Brown	T-ins 3	Medium	Co 1
S. 2002	Goat leather	Yellow-brown	T-ins 2	Medium	varies
S. A. 0351	Sheep? leather	Yellow-brown	T-ins 3	Medium	Co 2

Table 75. Cover information.



Catalogue Number	Left / Right difference?	Decoration pattern	Spine decoration pattern	Board edges decoration	Decoration tools	Number of tools
S. 0356	No	Dec 2ab	None ?	None	MuF/c6, MuF/d3, MuF/e16, MuF/e17, RoF10, fillets	6
S. 0574	No	Dec 10a	Yes, improvised	BD6 (RoF10) +3 fillets all along the FE	MuF/e13, MuF/e16, RoF10, fillets	4
S. 2002	No	Dec 14a?	None	None	MuF/d4, MuV4, CeR40, fillets	4
S. A. 0351	No	Dec 14a	None	None	MuF/c6, MuF/e16, MuF/e17, RoF10, fillets	5

Table 76. Decoration information.

Tool	Volumes where it is used	Number of volumes where it is used
MuF/c6	S. 356, S.A. 351	2
MuF/d3	S. 356	1
MuF/d4	S. 2002	1
MuF/e13	S. 574	1
MuF/e16	S. 356, S. 574, S.A. 351	3
MuF/e17	S. 356, S.A. 351	2
MuV4	S. 2002	1
CeR40	S. 2002	1
RoF10	S. 356, S. 574, S.A. 351	3
Fillets	All volumes	4

Table 77. Tools information

Catalogue Number	Metal furniture type	Attachment method	Metal	Format of text-block	Thickness of text-block
S. 0356	Bosses	Nailed, edges underneath pastedown	N.k.	4to	80
S. 0574	None	-	-	8vo	40
S. 2002	None	-	-	16mo	20
S. A. 0351	None	-	-	8vo	56

Table 78. Metal fittings information.

Catalogue Number	Number of fastenings	Fastenings type	Fastenings material	Strap anchorage type	Fastenings & Turn-ins arrangement	Ends form	Arrangement of anchorage holes	Format of text-block	Thickness of text-block
S. 0356	0-1-0 ←	Three edged leather interlaced straps / N.k.	DtC, metal	TBTP	F & T 6	TfaP	AH 4	4to	80
S. 0574	0	None	-	-	-	-	-	8vo	40
S. 2002	0-2-0 →←	Leather ties	SaC	TBP	F & T 6	UfaP	AH 5	16mo	20
S. A. 0351	0-2-0 →←	Leather ties	SaC	TBTP	F & T 1	TfaP	AH 5	8vo	56

Table 79. Fastenings information

## THE ELUSIVE ATELIER BINDINGS

Catalogue number	Text chronology	Title	Scribe	Format of text-block	Number of leaves	Notes	Original binding?
S 0619	15 <sup>th</sup> c.	June Meneon (L)	N.k.	4to (280 x 190)	367 WpP		No, at least 2 <sup>nd</sup>
S 0629	15 <sup>th</sup> c.	July Meneon (L)	N.k.	4to (280 x 192)	221 WpP		No, at least 2 <sup>nd</sup>
S 0634	15 <sup>th</sup> c.	August Meneon (L)	N.k.	4to (280 x 190)	232 WpP	There is a note, difficult to read, in the last text leave bearing the date 1721 (see photos)	No, at least 2 <sup>nd</sup>
S 0678	1666	Services (L)	Mathaios	8vo (200 x 143)	215 WpP	f. 211r. A long note that ends like this : «... Γράψαντος ματαθίου τληπαθούς και επιλυπτικού όπως εις αυτόν και εις άπαντας τους αδελφούς πάντοτε οι άγιοι ποιούντες τας προσβείας. Δια δαπάνης δανιήλ ιεροδιακόνου και ο φοβούμενος τον θεόν μη ξενώσας αυτό άχζστ' (1666 AD) μηνί αυγούστου ιδ'».	Yes
S 0803	15 <sup>th</sup> -16 <sup>th</sup> c.	Paraklitiki (L)	N.k.	4to (285 x 205)	230 WpP	-	No, at least 2 <sup>nd</sup>
S 0808	15 <sup>th</sup> c.	Paraklitiki (L)	N.k.	4to (286 x 200)	206 WpP	f. 198 v. «Ετους ζ[...]νη' (7 [...]58 AM ) μηνί ιουλίου εις την πρώτην προσλίωσα εγώ γερμανός αχ[ριος] και οικονόμος της κρίτης το παρόν βιβλίον ήγουν την παρακλητικήν εις την θείαν και ιεράν βασιλικήν μονή της μεγάλης εκκλησίας του αγίου και θεοβαδιστου όρους σινά...»	No, at least 2 <sup>nd</sup>
S 1110	1523	Typicon (L)	Patriarch Ioakim	8vo (248 x 180)	261 WpP	f. 253 r. «Επροσιλόθη το παρόν πικρόν εν τω αγίω όρι σινά και ει της το σερισι εκ της αυτής μονής να έχει τας άρας των αγίων πατέρων ή κόψη ετούτα τα γραμάτια ή βάνι όλον και κόψιτω να έχει και αυτός ομοίως τα επιτήμια. Ετι ζ[...]λα' (7[...]31 AM) εν μηνί μαίω κδ' ανήμεραν την πεντικοστή ο γράψας Ιωακείμ πατριάρχης ιωακείμ»	No, at least 2 <sup>nd</sup>
S 1963	1667	Canons (L)	Gregorios	24to (144 x 102)	244 WP	f. 222r. «Δόρο θεού και γρηγορίου πόνοσ εγραθή το παρόν επί ετούς 1667 και οι αναγνώσκοντες εύχεσθαι υπέρ ημών ότι υπάρχω πολλά ευτελής και αχριος παρά πάντων» f. 222v. «Το παρόν νομικόν υπάρχει εμού γρηγορίου ιερομονάχου του κυπραίου»	Yes
S 2062	1660	Psalterion (L)	Mathaios	8vo (200 x 145)	232 WpP	f. 232v. «Πέρασ ειληφε και τω θεώ δόξαν δόμεν εμού πόνοσ ματαθίου και αναζίου οι συνάπτοντες δεήσεις ποιήσουσιν υπέρ αυτών και εμού του αχρίου η δαπάνη πέφυκε παρθενίου του γούναρι και ποιήσοι ως βούλεται έτους αχζ' (1660 AD) μαρτίου ιστ'»	Yes

Table 80. Text-block information.

Catalogue number	Original binding?	Spine Repair/Reinforcement Type/Material	Text-block Repair Material
S 0619	No, at least 2 <sup>nd</sup>	Western paper strips pasted both locally and all along the spine-folds	Some leaves in the beginning of the text-block are framed with western paper
S 0629	No, at least 2 <sup>nd</sup>	Western paper strips pasted both locally and all along the spine-folds	Some leaves in the beginning of the text-block are framed with western paper
S 0634	No, at least 2 <sup>nd</sup>	Western paper strips pasted both locally and all along the spine-folds	Some leaves in the beginning of the text-block are framed with western paper
S 0678	Yes		
S 0803	No, at least 2 <sup>nd</sup>	Most of the leaves were trimmed along the spine and were consecutively turned into bifolia through paper strips pasted all along the spine edge of conjugate leaves.	Western paper strips pasted in trimmed edges of some leaves.
S 0808	No, at least 2 <sup>nd</sup>	Western paper strips pasted both locally and all along the spine-folds	Western paper strips pasted in trimmed edges of some leaves
S 1110	No, at least 2 <sup>nd</sup>	Most of the leaves were trimmed along the spine and were consecutively turned into bifolia through paper strips pasted all along the spine edge of conjugate leaves.	Western paper strips pasted in trimmed edges of some leaves
S 1963	Yes		
S 2062	Yes		

Table 81. Repair information

Catalogue number	Original binding ?	Left endleaf unit arrangement	Right endleaf unit arrangement
S 0619	No, at least 2 <sup>nd</sup>	Similar to S. 629?	Similar to S. 629?
S 0629	No, at least 2 <sup>nd</sup>	[1] 1 +	See figure 47
S 0634	No, at least 2 <sup>nd</sup>	[1] 1 tipped	+ 3 [1]
S 0678	Yes	Unclear	Unclear
S 0803	No, at least 2 <sup>nd</sup>	[1] 3	3 [1]
S 0808	No, at least 2 <sup>nd</sup>	[2] 4	2 [2]
S 1110	No, at least 2 <sup>nd</sup>	Similar to S. 629?	Similar to S. 629?
S 1963	Yes	[1] 7	+ 1 [1]
S 2062	Yes	[1] 5	Unclear

Table 82. Endleaves information.

Catalogue number	Number of sewing stations	Distance between stations / Pattern of sewing stations	Kind of Sewing	Accommodation nicks	Sewing notes	Thickness of text-block	Format of text-block
S 0619	5	30-42-55-53-57-33 / B1?	Unsupported	V-shaped cuts		34	4to
S 0629	6	25-42-38-46-45-47-28 / B1?	Unsupported	Single knife cuts		30	4to
S 0634	5	27-45-55-55-55-33 / B1	Unsupported	V-shaped cuts		40	4to
S 0678	N.k. (6)	N.k. / N.k. (11-12-50-47-45-20-14 B4B6)	Unsupported (supported)	V-shaped cuts	There are two sewing structures in this volume, the first is unsupported and the later is supported on four raised cord supports. Both sewing phases are preserved.	22	8vo
S 0803	5	30-47-50-50-67-35 / B3?	Unsupported	V-shaped cuts		40	4to
S 0808	5	32-50-45-46-68-38 / B3	Unsupported	Tiny V-shaped cuts		37	4to
S 1110	5	20-40-42-45-50-35 / B3?	Unsupported	V-shaped cuts		40	8vo
S 1963	4	18-27-39-39-19 / B1?	Unsupported	V-shaped cuts		30	24to
S 2062	3	40-65-62-35 / B1	Unsupported	Tiny V-shaped cuts		30	8vo

Table 83. Sewing information. (Red colour indicates features of the later supported sewing structure)

Catalogue number	Sewing thread	Sewing thread thickness	Sewing thread twist	Sewing thread ply
S 0619	Linen waxed	Thick	Loose	Multiple Z
S 0629	Linen waxed	Thick	Loose?	?S
S 0634	Linen waxed	Thick	Loose	Multiple Z
S 0678	Linen (Cotton)	Medium (Fine)	Tight (Tight)	? Z (2 2S)
S 0803	Hemp	Medium-coarse	Loose	Multiple S
S 0808	Hemp	Thick	Medium	S
S 1110	Linen	Medium	Medium	6 2s Z
S 1963	Linen?	Medium	Medium?	2?Z
S 2062	Linen	Medium	Tight	?Z

Table 84. Sewing thread information.

Catalogue number	Attachment system	Attachment thread	Material	Board edge groove	Spine edge treatment	Spine joints	Thickness of boards	Format of text-block	Thickness of text-block
S 0619	I Uns/ 10	N.v.	Wood	BG 3	SET 3	90°	11	4to	56
S 0629	I Uns/ 10	N.v.	Wood	BG 3	SET 3	90°	9	4to	30
S 0634	I Uns/ 10	N.v.	Wood	BG 3	SET 3	120°	11	4to	40
S 0678	Nk (Sup 7)	N.v.	Wood	BG 3	SET 7	90°	9	8vo	22
S 0803	N.v.	N.v.	Wood	BG 3	SET 7	90°	12	4to	40
S 0808	N.v.	N.v.	Wood	BG 3	SET 3	45°	10	4to	37
S 1110	I Uns/ 10	N.v.	Wood	BG 3	SET 3	90°	12	8vo	40
S 1963	I Uns/ 10	N.v.	Wood	BG 3	SET 7	90°	8	24to	30
S 2062	I Uns/ 10	N.v.	Wood	BG 3	SET 3	120°	7	8vo	30

Table 85. Boards information. (Red colour indicates features of the later boards attachment structure related to the later resewing of the volume on four cord supports).

Catalogue number	Spine lining	Material	Thickness	Board covered	Side of boards covered	Spine shape	Thickness of text-block
S 0619	Yes, all through	Canvas	Medium	N.v.	Outside	Round	
S 0629	Yes, all through	Canvas	Fine	N.v.	Outside	Round	30
S 0634	Yes, all through	Canvas	Medium	N.v.	Outside	Round	40
S 0678	None	-	-	-	-	Round	22
S 0803	Yes, all through	Canvas	Medium	N.v.	Outside?	Round	40
S 0808	Yes, all through	Canvas	Thick	N.v.	Outside	Round	37
S 1110	Yes, all through	Canvas	Medium	N.v.	Outside	Round	40
S 1963	Yes, all through	Canvas	Fine	30%?	Outside	Round	30
S 2062	Yes, all through	Canvas	Fine	N.v.	Outside	Round	30

Table 86. Spine lining information.

Catalogue number	Number of cores	Endband primary sewing (E. P. S.) type	First core material	Second core material	Third core material	First core thickness	Second core thickness	Third core thickness	Distance of projection	Endband anchoring system
S 0619	3	N.v.	Cord	N.v.	Red silk thread	Medium	Medium	Thin	30 mm - 16.2%	EAS 2
S 0629	3	N.v.	Cord	N.v.	Red silk thread	Medium	Medium	Thin	25 mm - 13.1%	EAS 2
S 0634	3	N.v.	Cord	N.v.	Red silk thread	Medium	Medium	Thin	25 mm - 13.1%	EAS 2
S 0678	3	N.v.	Wool (?)	N.v.	Thread?	Medium	Medium?	Thin	None, endband projections onto boards cut during rebacking	N.k.
S 0803	3	N.v.	Cord?	Multiple thread (SaS) lengths	Thread?	Medium?	Medium	Thin	20 mm - 10.5%	EAS 2
S 0808	3	N.v.	Cord	N.v.	Thread?	Medium	Medium?	Thin	22 mm - 11.5%	EAS 2
S 1110	3	N.v.	Cord?	N.v.	Thread?	Medium?	Medium?	Thin	20 mm - 11.7%	EAS 2
S 1963	3	Wound of some type on 1 <sup>st</sup> core	Cord?	Multiple thread (SaS) lengths	Red silk thread	Medium	Medium	Thin	10 mm - 11.1%	EAS 2
S 2062	3	Wound of some kind on 1 <sup>st</sup> core	Cord	Multiple thread l(SaS) lengths	Red Silk thread	Medium	Medium	Thin	22 mm - 15.9%	EAS 2

Table 87. Endband cores information.

Catalogue number	E. P. S. type	E. P. S. thread	E. P. S. thread thickness	E. P. S. thread ply	E. P. S. thread twist	Number of tie-downs	Tie-downs position	Thread anchorage
S 0619	N.v.	Linen (Waxed?)	Fine	?S	Loose?	As many as gatherings	Centre-fold	Uses other passing hole outside
S 0629	N.v.	Linen (Waxed?)	Fine	?Z?	Loose?	As many as gatherings	Centre-fold	Uses change-over station
S 0634	N.v.	Linen Waxed	Fine	4S	Loose	As many as gatherings	Centre-fold	Uses other passing hole outside
S 0678	N.v.		N.k.	N.k.	N.k.	As many as gatherings?	N.k.	N.k.
S 0803	N.v.		N.k.	N.k.	N.k.	As many as gatherings?	N.k.	N.k.
S 0808	N.v.		N.k.	N.k.	N.k.	As many as gatherings?	N.k.	N.k.
S 1110	N.v.		N.k.	N.k.	N.k.	As many as gatherings?	N.k.	N.k.
S 1963	Wound of some type on 1 <sup>st</sup> core	Linen	Fine	2 ? Z	Tight	As many as gatherings	Centre-fold	Uses change-over station(H), other hole outside (I)
S 2062	Wound of some kind on 1 <sup>st</sup> core	Linen	Fine	?S	Tight	As many as gatherings?	Centre-fold	Uses change-over station

Table 88. Endband primary sewing information.

Catalogue number	Endband secondary sewing (E. S. S.) type	E. S. E. thread	E. S. S. colours	E. S. S. thread thickness	E. S. S. thread ply	E. S. S. thread twist
S 0619	3-core Chevron & crowning core (2 colours)	Silk	Black, white	Fine	2S	Tight
S 0629	3-core Chevron & crowning core (2 colours)	Silk	Black, white	Fine	2S	Tight
S 0634	3-core Chevron & crowning core (2 colours)	Silk	Black, white	Fine	2S	Tight
S 0678	3-core Chevron & crowning core (3 colours)	Silk	Cyan, white, pink	Fine	2S	Tight
S 0803	3-core Chevron & crowning core (3 colours)	Silk	Cyan, white, pink	Fine	2S	Tight
S 0808	3-core Chevron & crowning core (3 colours)	Silk	Cyan, white, pink	Fine	2S	Tight
S 1110	3-core Chevron & crowning core (2 colours)	Silk	Black, white	Fine	2S	Tight
S 1963	3-core Chevron & crowning core (3 colours)	Silk	Cyan, white, pink	Fine	2S	Tight
S 2062	3-core Chevron & crowning core (3 colours)	Silk	Cyan, white, pink	Fine	2S	Tight

Table 89. Endband secondary sewing information.

Catalogue number	Marker	Primary marker	Primary marker material & colour	Primary M way of attachment	Secondary marker	Secondary marker material & colour	Secondary M way of attachment
S 0619	Compound	2 simple kinked closed loops (2 colours)	1 black & 1 white silk threads (SaE)	LtH(f)	Missing	-	-
S 0629	Compound	2 simple kinked closed loops (2 colours)	1 black & 1 white silk threads (SaE)	LtH(f)	Missing	-	-
S 0634	Compound	2 simple kinked closed loops (2 colours)	1 black & 1 white silk threads (SaE)	LtH(f)	Missing	-	-
S 0678	Compound	1 simple kinked closed loop (3 colours)	1 cyan, 1 pink & 1 white silk threads (SaE)	LtH(f)	1 multicoloured string	Cyan, pink, white silk threads twisted together	N.k. (broken)
S 0803	Compound	3 simple kinked closed loops (3 colours)	1 cyan, 1 pink & 1 white silk threads (SaE)	LtH(f)	1 multicoloured string	2 strings, each red & blue silk threads, twisted together	KiM
S 0808	Compound	2 simple kinked closed loops (3 colours)	1 cyan, 1 pink & 1 white silk threads (SaE)	LtH(f)	1 multicoloured string	Blue, red silk threads twisted together	KiM
S 1110	Compound	2 simple kinked closed loops (2 colours)	1 black & 1 white silk threads (SaE)	LtH(f)	1 multicoloured string	Red, yellow, blue silk threads twisted together	KiM, through both primary markers
S 1963	Compound	1 simple kinked closed loop (3 colours)	1 cyan, 1 pink & 1 white silk threads (SaE)	LtH(f)	1 multicoloured string	2 strings, each red & blue silk threads, twisted together	KiM
S 2062	None						

Table 90. Markers information.

Catalogue number	Cover material	Cover colour	Turn-ins type	Turn-ins width	Corners mitre
S 0619	Goat leather	Yellow-brown	T-ins 1, T-ins 2	Narrow	Co 7, Co 6
S 0629	Goat leather	Yellow-brown	T-ins 1, T-ins 2	Narrow	Co 6
S 0634	Goat leather	Yellow-brown	T-ins 1, T-ins 2	Narrow	Co 7, Co 6
S 0678	Goat leather	Yellow-brown	T-ins 1, T-ins 2	Narrow	Co 7
S 0803	Goat leather	Yellow-brown	T-ins 1, T-ins 2	Medium	Co 1, Co 6
S 0808	Goat leather	Yellow-brown	T-ins 1, T-ins 2	Narrow	Co 6
S 1110	Goat leather	Yellow-brown	T-ins 1, T-ins 3?	Narrow	Co 1
S 1963	Goat leather	Yellow-brown	T-ins 1, T-ins 2	Narrow	Varies
S 2062	Goat leather	Yellow-brown	T-ins 1, T-ins 2	Narrow	Co 1, Co 6

Table 91. Cover information.

Catalogue number	Left / Right difference ?	Decoration patterns	Spine decoration pattern	Board edges decoration pattern	Decoration motifs	Number of tools used
S. 0619	No	Dec13ab	None	BED 2 (2 rings), BD 10 (3 rings)	MuF/a7, MuF/a8, MuF/c7, MuF/c41, MuF/d1, MuF/d7, MuG/a1, MuG/a4, fillets	9
S 0629	Yes	Dec13a + Dec3 Dec13ab + Dec2	None	BED 2 (2 rings), BD 10 (3 rings)	MuF/a7, MuF/a8, MuF/c7, MuG/a1, MuG/a4, fillets	7
S 0634	No	Dec13ab Dec13ab + Dec10	None	BED 2 (2 rings) BD 10 (3 rings)	MuF/a7, MuF/a8, MuF/c7, MuF/d1, MuF/d7, MuG/a1, fillets	7
S 0678	No	Dec13a	None	BED 2 (2 rings) (endband area covered with rebacking)	MuF/a7, MuF/a8, MuF/c7, MuF/c41, MuF/d1, MuF/d7, MuG/a4, fillets	8
S 0803	Yes	Dec13ab+Dec12+Dec1a (L) Dec13ab + Dec10 (R)	None	BED 2 (2 rings), BD 10 (3 rings)	MuF/a7, MuF/a8, MuF/c41, MuF/d1, MuF/d7, MuG/a1, MuG/a4, MuG/b10, fillets	9
S 0808	Yes	Dec13ab+Dec12+Dec1 (L) Dec13ab (R)	None	BED 2 (2 rings), BD 10 (3 rings)	MuF/a7, MuF/a8, MuF/c7, MuF/c41, MuF/d1, MuF/d2, MuF/d6, MuF/d7, MuG/a1, MuG/a4, fillets	11
S 1110	No	Dec13ab	None	BED 2 (2 rings), BD 10 (3 rings)	MuF/a7, MuF/a8, MuF/c7, MuF/c41, MuF/d1, MuF/d7, MuG/a4, fillets	8
S 1963	No	Dec13a	None	BED 2 (2 rings), BD 10 (3 rings)	MuF/a7, MuF/a8, MuF/c41, MuF/d1, MuF/d7, MuG/a1, MuG/a4, fillets	8
S 2062	No	Dec13a	None	BED 2 (2 rings), BD 10 (3 rings)	MuF/a7, MuF/a8, MuF/c7, MuF/c41, MuF/d1, MuF/d7, MuF/d36, MuG/a4, fillets	9

Table 92. Cover Decoration information.

Tool	Volumes where it is used	Number of volumes where it is used
MuF/a7	All nine volumes	9
MuF/a8	All nine volumes	9
MuF/c7	All volumes except S. 803, S. 1963	7
MuF/c41	All volumes except S. 634	8
MuF/d1	All volumes except S. 629	8
MuF/d2	S. 808	1
MuF/d6	S. 808	1
MuF/d7	All volumes except S. 629	8
MuF/d36	S. 2062	1
MuG/a1	All volumes except S. 678, S. 1963, S. 2062	6
MuG/a4	All volumes except S. 634	8
MuG/b10	S. 808	1
Fillets	All volumes	9

Table 93. Tools information.

Catalogue number	Edge decoration	Colour
S 0619	Drawn and painted floral motifs	Black, red, green
S 0629	Drawn and painted floral motifs	Black, red, green, ochre
S 0634	Drawn and painted floral motifs	Black, red, green, ochre
S 0678	Drawn and painted plait-work motifs	Red, green
S 0803	Drawn and painted plait-work motifs	Red, green
S 0808	Drawn and painted plait-work motifs	Red, green
S 1110	Drawn and painted religious figures ( <i>The Deisis</i> )	Black, red, green, yellow, pink
S 1963	Drawn and painted plait-work motifs	Black, red, green (?)
S 2062	None	-

Table 94. Edge decoration information.

Catalogue number	Metal furniture type	Metal	Number of Furniture	Attachment method
S 0619	Bosses	Copper alloy	5 L, 5 R	Nailed, ends originally underneath the pds
S 0629	Bosses	Copper alloy	5 L, 5 R	Nailed, ends originally underneath the pds
S 0634	Bosses	Copper alloy	5 L, 5 R	Nailed, ends underneath the pds
S 0678	None	-	-	-
S 0803	Bosses	Copper alloy	4 L, 4 R	Nailed, ends not visible
S 0808	Bosses	Copper alloy	4 L, 5 R	Nailed, ends underneath the pds
S 1110	Bosses & high relief corners and centrepiece	Copper alloy	5 L, 5 R	Nailed, ends not visible
S 1963	None	-	-	-
S 2062	None	-	-	-

Table 95. Metal fittings information.

Catalogue number	Num. of fastenings	Fastenings type	Fastenings material	Strap anchorage type	Fastenings & T-ins arrangement	Ends form	Arrangement of anchorage holes	Format of text-block	Thickness of text-block
S 0619	0-2-0 ←	Three edged leather interlaced straps / standard type	SaC and metal	TB	F & T 6	TbPpPC	AH 4	4to	56
S 0629	0-1-0 ←	Three edged leather interlaced strap / standard type	SaC and metal	TB	F & T 6	TuP	AH 4	4to	30
S 0634	0-2-0 ←	Three edged leather interlaced straps / standard type	SaC and metal	TB	F & T 6	TbPpPC	AH 4	4to	40
S 0678	0-1-0 ←	Three edged leather interlaced strap / N.k.	SaC and metal	TBP	F & T 6	TbPpPC	AH 4	8vo	22
S 0803	0-2-0 ←	Three edged leather interlaced straps / standard type	DtC and metal	TB	F & T 2?	TuP	AH 4	4to	40
S 0808	0-2-0 ←	Three edged leather interlaced straps / standard type	DtC and metal	TB	F & T 6	TuP	AH 4	4to	37
S 1110	0-2-0 ←	Three edged leather interlaced straps / N.k.	SaC and metal	TBTP	F & T 6	TbPpPC	AH 4	8vo	40
S 1963	0-2-0 ←	Three edged leather interlaced straps / standard type	SaC and metal	TB	F & T 6	UuP	AH 4	24to	30
S 2062	0-1-0 ←	Three edged leather interlaced straps / standard type	SaC and metal	TBP	F & T 6	TbPpPC	AH 4	8vo	30

Table 96. Fastenings information.



THE RAITHOS ATELIER

Catalogue number	Text chronology	Title	Scribe/s	Format of text-block	Number of leaves	Notes
S 0076	1654	Psalter & Odes(T)	Mathaios hieromonk	8vo (210 x 156)	237 WpP	At the end «Το παρόν ψαλτήριον υπάρχει εμού κωνσταντίου αχ(?) να το έχω να το διαβάζω έως ού ο θεός βούλεται του ζείν με και μετά ταύτα να είναι εις το άγιον μοναστήριον του σινά και να μην έχει εξουσία πνάς να το ξενώσει μη βλάψει την ψυχήν του: αχζ' (1663 AD) μηνί φεβρουαρίου δ' κωνσταντίου αχ(?) και οικονόμος» «Ματθαίου τήπαθούς και επιλυπτικού θεού συνεργεία πέρας έλαβεν το παρόν επί έτους αχρδ' (1654 AD) ζρξβ' (7162 AM = 1654 AD) μαρτίου ζ»
S 0088	17th c.	Psalter & Odes(T)	N.k.	8vo (200 x 140)	223 WpP	
S 0426	1653	Climax (T)	Mathaios hieromonk	4to (310 x 215)	176 WpP	f. 169 r. «Εγράφη υπ εμού αματωλού ματθαίου ιερομονάχου αναλώμαση κύρ μαλαγία πέρας ελήφην θεού συνεργεία επί έτι αχγγ' (1653 AD). ζρζα' (7161 AM = 1653 AD) μηνί οκτωβρίου λα' ». On the verso of the same leaf there is a note, in the hand of archbishop Ioasaph, saying that the book was dedicated to the big church (The Katholicon) of the monastery by Mathaios and Malachias.
S 0433	1652	Paladiou Laphsaiko(T)	Mathaios hieromonk	4to (302 x 210)	292 WpP	f. 286 v. «Ετελειώθη το παρόν θεού ευδοκία εν μηνί οκτωβρίου κη' επί έτους ζρξ' (7160 AM = 1652 AD) υπ εμού αματωλού ματθαίου ιερομονάχου και δια δαπάνης μαλαγίου μοναχού και οι συνάπτωντες εύχεσθαι υπέρ ημών». Just below this note there is another one in the hand of Archbishop Ioasaph of an almost identical content as in the previous manuscript.
S 0710	17th	Services (L)	N.k.	8vo (210 x 155)	137 WpP	
S 0764	15th c 1st half of?	Pentecostarion(L)	N.k.	8vo (267 x 200)	207 WP	f. 200 r. a note in Arabic mentions the owner and the date 1559 A. D. Also rebinding note, see next table
S 0931	14th - 15th c	Ermologion(L)	N.k.	24to (146 X 104)	164 Par&Pap	
S 1768	15th-16th c.	Speeches of St. Ephraem the Syrian (T)	N.k.	8vo (210 x 1350)	168 WP	
S 1814	1660	Horologion (L)	Mathaios hieromonk	8vo (200 x 143)	181 WpPWP	f. 174 r. «Εν τη Ραιθώ μονή των Σιναιτών και πατέρων βρίσκονται κατά καιρόν ασκούντων. Ένθα αι πηγαί δώδεκα των υδάτων και φονικών στέλεχοι επτάκις δέκα πάντων. Επακτασχιλιστώ εκατοστό εζκοστώ σγδόω (7168 AM = 1660 AD) μηνί ιουνίου κ(...)'». Kamil dates it in the 18th century as well as Bathja Bayer (the Jewish National and University library)
S 1856	1662	Kiriakodromion (L)	Leontios monk	8vo (205 x 140)	260 WpP	f. 245 v. «Κατά έτος το σωτήριον αχζβ' (1662 AD) μηνί μαρτίου ιβ' ημέρα δ' ώρα γ' ουκ ίσχυσεν μέλανος ουδέ χαρτίου μηδέ χείρ ουδέ του καλάμου εισχίς θεού ο κτίστης των απάντων κόπος εμού αχρίου αναζίου ο κληθής λεόντιος ευτελής των ιερομονάχων. Οι σφαλιμάτων πέρυκεν συγγώμην παρέχεται μοι. Αμαθίς γαρ ων και πρώτον μου γραμμένον. Σπερ ζένη...εγράφη εν ραιθού».
S 1996	1657	Theological treatises (T)	Gerasimos hieromonk	16mo (152 x 107)	59 WpP	f. 56 r. «Αυτή η λειτουργία εγράφη υπ εμού γερασίου ιερομονάχου του κυπρέου και την αφιέρωσα εις την εκκλησίαν της ραιθώ της υπεραγίας θεοτόκου και ο ζενώσας αυτήν αλλόφριος έστω της μερίδος χριστού και την υπεραγίαν θεοτόκον να έχει αντίδικον εν ημέρα κρίσεως αχζ' (1658 AD) ιουνίου ε'».
S 2056	1660	Psalms (T)	Mathaios & Ioannikios	8vo (200 x 145)	208 WpP	In the end «Τω θεώ δόξα τέλος αχζ' (1660 AD)απριλλίου κβ' δια ιερομονάχων σοφού Ιωαννικίου ματθαίου έγραψεν αματωλός και αχρείος όπως εύχεται υπέρ αυτού αμφοτέροι συναίται και μη ζενωθείη από σινά».
S 2140	1689?	Liturgy of St. J. Chrysostom (L)	N.k.	8vo (205 x 150)	30 WpP	

Table 97. Text-block information.

Catalogue number	Date of Binding	Type of binding	Place of Binding	Binder	Note	Original binding?
S 0076	17th c. 2nd half	Greek-style with supports		N.k.		Yes
S 0088	17th c. 2nd half	Greek-style with supports.	Raithos	N.k.		Yes
S 0426	1653	Greek-style	Raithos	N.k.		Yes
S 0433	1652	Greek-style	Raithos?	N.k.		Yes
S 0710	17th c. 2 <sup>nd</sup> half	Flush pbs, unsupported	Raithos	N.k.		Yes
S 0764	17th c. mid	Greek-style	Raithos	Leontios hieromonk?	f. 200 v. «Το παρόν πενηκοστήριον εἶτον πολλά χαλασμένον και ενσταχάθη εν ραῖθού και εδοκημάσται και υπό ετέρων ἀδελφών ἀλλά οὐδὴς το ετελώσε, και ο ποιήσας) ὡν ορ(ας) αὐτός έχει (και) τον κόπον ὡν ο θεός εἶδεν και ο ἀλλοτριώσε εκ της μονῆς τας υπεραγίας Θεοτόκου της εν ραῖθού ἔστω ἀλλότριος της μερίδας του εξ αὐτῆς τεχθέντος υἱοῦ του Θεοῦ. οεληνβλς ιε λζηνθολς»	No, at least 2nd
S 0931	1664	Greek-style	Sinai?	Akakios from Ioannina	f. 164 r. : «Το παρόν εστάχως(εν) ο εν ιεροδιακόνις κύρ ακάκιος ο εκ των Ιωαννίνων ἔλκων τω γένος ο Θ(εο)ς συγχωρέσι του το ἀνωθ(εν) εγράψα εγώ λεόντιος ευτελής και αμαρτωλός κ(αι) 1664 ιουλίου 16 και πολλ(ῶ) πικραμένος του βίου την θάλασσαν ναούς τους αγίους σου εν τα ὄρει τῶ σινά κ(αι) την αγίαν πανσεβάσιμον κορυφήν σκέβη κ(αι) κμίλια· οι εχθροί σου παρθένε καταπέτησαν +	No, at least 2nd
S 1768	17th c.	Greek-style	Sinai	N.k.		No, at least 2nd
S 1814	1660	Flush pbs with supports	Raithos	N.k.		Yes
S 1856	1662	Greek-style with supports,	Raithos?	N.k.		Yes
S 1996	1657	Greek-Islamic binding with flap	Raithos	N.k.		Yes
S 2056	1660?	Greek-style	Raithos?	N.k.		Yes
S 2140	1689	Flush pbs with supports	Sinai?	Nikeforos hieromonk	f. 21r. : «Μέμνησθε τοῖνον ἀδελφοί ὅσοι ιερουργεῖτε ἐνδόν της βῆτου της σεπτῆς και δέσην ποιήτε υπέρ εμοῦ του δέσαντος αὐτήν την λειτουργίαν ὅπως ρυσθῆίς εκ των δεινῶν ευρήσω σωτηρίαν. Νικηφόρου το ὄνομα και ιερομονάχου και ἱγνατίου μοναχοῦ η αἰτία γαρ ἦν αὐτοῦ σωτήριον ἔτος 1689 μαρτίου 15».	Yes

Table 98. Binding information.

Catalogue number	Original binding?	Spine-fold repair type and material	Text-block Repair Material
S 0076	Yes		
S 0088	Yes	Few western paper strips pasted locally and all along the spine-folds of gatherings.	
S 0426	Yes	Western paper strips pasted locally in the spine fold of the 1st gathering	
S 0433	Yes		
S 0710	Yes		
S 0764	No, at least 2nd	Western paper strips pasted locally and all along the spine-folds.	Western paper pasted in leaves' edges.
S 0931	No, at least 2nd	Parchment, blank and Ms waste, strips pasted locally and all along the spine-folds.	Western polished paper pasted in leaves' edges
S 1768	No, at least 2nd	Western paper Ms waste strips pasted locally and all along the spine fold of leaves and gatherings. The first gathering consists of single leaves tuned into bifolia through paper pasted in the spine-folds.	Western paper Ms waste pasted in damaged areas
S 1814	Yes		
S 1856	Yes		
S 1996	Yes		
S 2056	Yes		
S 2140	Yes		

Table 99. Repair information

Catalogue number	Left endleaf unit arrangement	Right endleaf unit arrangement	Original binding?
S 0076	[1]+	+2 [1]	Yes
S 0088	[1]+	+ [1]	Yes
S 0426	[1] 3	+2 [1]	Yes
S 0433	[1] 3	+3 + 3 [1]	Yes
S 0710	[1] 1 +	+ 1 [1]	Yes
S 0764	[1] 3	5 [1]	No, at least 2nd
S 0931	[1] +	3 [1]	No, at least 2nd
S 1768	[1] 3	3 [1]	No, at least 2nd
S 1814	[1] 5+	+ 2 + 1 [1]	Yes
S 1856	[1] 5	3 [1]	Yes
S 1996	[2] 2	+ 1 [2]	Yes
S 2056	[1] 3	+ 1 [2]	Yes
S 2140	[1] 3	+ 1 + 3 [1]	Yes

Table 100. Endleaf units information.

Catalogue number	Number of sewing stations	Distance between stations/ pattern of sewing stations	Kind of Sewing	Accommodation nicks	Supports material	Supports thickness	Supports number	Supports type	Format of text-block	Thickness of text-block
S 0076	5	30-40-40-38-38-22 / B1	Supported	V-shaped cuts	Black leather thong flat	Rather thin	1-1-1	Raised	8vo	41
S 0088	3	45-52-54-42 / A B1	Supported	Tiny V-shaped cuts	Split Leather thong flat	Medium	1-1-1	Raised	8vo	30
S 0426	3	45-110-115-35 / B1	Unsupported	V-shaped cuts	-	-	-	-	4to	22
S 0433	5	30-60-63-60-60-26 / B1	Unsupported	Tiny V-shaped cuts	-	-	-	-	4to	36
S 0710	3	30-75-75-30 / B1	Unsupported	Needle holes	-	-	-	-	8vo	18
S 0764	5	32-50-55-60-30-36 / B1?	Unsupported	V-shaped cuts?	-	-	-	-	8vo	35
S 0931	5	11-8-45-47-13-15 / B6	Supported	V-shaped cuts	Split leather thong flat	Thick	1-1-1	Raised	24to	26
S 1768	4	26-54-55-55-26 / B1	Unsupported	Needle holes?	-	-	-	-	8vo	30
S 1814	5	22-15-60-60-17-25 / C3	Supported	Needle holes?	Split leather thong flat	Medium	1-1-1	Raised	8vo	28
S 1856	6	16-20-37-40-40-22-25 / B6	Supported	Tiny V-shape cuts	Split leather thong flat	Medium	1-1-1-1	Raised	8vo	35
S 1996	3	28-50-50-25 / B1	Unsupported	Needle holes	-	-	-	-	16mo	12
S 2056	5	22-22-52-53-20-21 / B6	Supported	Needle holes	Leather thong flat	Medium	1-1-1	Raised	8vo	33
S 2140	5	30-36-36-32-35-30 / A B1	Supported	Needle holes	Cord	Medium	1-1-1	Raised	8o	6

Table 101. Sewing information.

Catalogue number	Sewing thread	Sewing thread thickness	Sewing thread twist	Sewing thread ply
S 0076	Hemp	Thin	Loose	?Z
S 0088	Hemp waxed	Medium	Medium?	?S
S 0426	Hemp	Medium	Loose	?S
S 0433	Hemp	Medium	N.k.	N.k.
S 0710	Linen	Medium	Tight	5S
S 0764	Hemp	Medium	Loose	S
S 0931	Linen	Thin	Medium	3S
S 1768	Linen	Thin	Loose	3?4?Z
S 1814	Linen	Thin	Tight	2 2s Z
S 1856	Linen	Thin	Tight	Z
S 1996	Linen	Thin	Medium	?Z
S 2056	Linen	Thin	Medium	2S
S 2140	Cotton?	Thin	Medium	2 2s Z

Table 102. Sewing Thread information.

Catalogue number	Attachment system	Material	Dimensions	Type of groove	Type of spine edge treatment	Spine joints	Spine shape	Thickness of boards	Format of text-block	Thickness of text-block
S 0076	Sup 9?	Wood	Flush	None	SET 3	Slight	Round	8	8vo	41
S 0088	Sup 9?	Wood	Flush	None	SET 4	Slight	Round	6	8vo	30
S 0426	I Uns/1	Wood	Flush	BG 5	SET 4	45°	Round	10	4to	22
S 0433	I Uns/1B	Wood	Flush	None	SET 3	45°	Round	10	4to	36
S 0710	Not visible	Pasteboard	Flush	None	SET 1	None	Flat	4	8vo	18
S 0764	I Uns/1	Wood	Flush	BG 5 only in F. E.	SET 3	45°	Round	10	8vo	35
S 0931	Sup 4	Wood	Flush	None	SET 3	90°	Slight round	6	24to	26
S 1768	I Uns/1	Wood	Flush	None	SET 3	90°	Round	9	8vo	30
S 1814	Sup 9	Pasteboard	Flush	None	SET 1	None	Flat	3	8vo	28
S 1856	Sup 9	Wood	Projecting, bevelled edges.	None	SET 3	100°	Round	7	8vo	35
S 1996	II Uns/B2	Pasteboard	Flush	None	SET 1	None	Flat	3	16mo	12
S 2056	Sup 4	Wood	Flush	None	SET 3	45°	Slight round	7	8vo	33
S 2140	Sup 5	Pasteboard	Flush	None	SET 1	None	Flat	3	8o	6

Table 103. Boards information.

Catalogue number	Spine lining	Material	Thickness	Side of boards covered	Board covered	Format of text-block	Thickness of text-block
S 0076	Yes, all along the spine?	Canvas	Medium	Outside	40%	8vo	41
S 0088	Yes, all along the spine	Canvas-like textile	Thick	Outside	30%	8vo	30
S 0426	Yes, all along the spine	Canvas	Medium?	Outside	20%	4to	22
S 0433	Yes, all along the spine	Blue canvas	Thin	Outside	N.v.	4to	36
S 0710	Yes, all along the spine	Canvas	Medium	None	None?	8vo	18
S 0764	Yes, all along the spine	Canvas	Thin	Outside	25%?	8vo	35
S 0931	Yes, all along the spine	Canvas	Medium	Outside	30%	24to	26
S 1768	Yes, all along the spine	Blue canvas	Medium	Outside	N.v.	8vo	30
S 1814	Yes, all along the spine	Canvas	Thin	Outside	N.v.	8vo	28
S 1856	Yes, all along the spine	Canvas	Medium	Outside	30%	8vo	35
S 1996	Yes, all along the spine	Canvas	Thin	Outside	N.v.	16mo	12
S 2056	Yes, all along the spine	Canvas	Medium	Outside	30%?	8vo	33
S 2140	Yes, all along the spine	Canvas	Medium	Outside	N.v.	8o	6

Table 104. Spine Lining information.

Catalogue number	Number of cores	Endband primary sewing (E. P. S.) type	First core material	Second core material	First core thickness	Second core thickness	Distance of projection	Endband anchoring system
S 0076	2	N.v.	Cord	Cord	Medium	Thin	27mm - 17.7%	EAS 1
S 0088	2	Wound plain on 1st core	Leather	Hemp thread	Medium	Thin	11 mm - 7.9%	N.v.
S 0426	2	Wound plain on 1st core	Cord	Thread	Thick	Medium	40 mm - 19.5%	N.v.
S 0433	2	Wound plain on 1st core ?	Cord	Thread	Thick	Thin	40 mm - 20%	EAS 1 with extra accommodation?
S 0710	1	Wound plain on core	Leather	-	Medium	-	30 mm - 19.7%	EAS 8 originally (?)
S 0764	2	Wound plain on 1st core ?	Cord	Thread	Medium	Thin	26 mm - 14%	N.v.
S 0931	1	Wound plain on core	Cord	-	Medium	-	19 mm - 17.4%	EAS 1
S 1768	2	Wound plain on 1st core	Wool thread	Thread (S. as. S)	Thick	Thin	25 mm - 24%	EAS 3
S 1814	1	Wound plain on core	Leather	-	Thin	-	A few mm.	EAS 8
S 1856	2	Wound plain on 1st core	Cord	Cord	Medium	Thin	11 mm - 8%	EAS 8
S 1996	1	Wound plain on core	Leather	-	Thin	-	6 mm - 5.6%	EAS 1
S 2056	1	Wound plain on core	Cord	Thread	Medium	-	24 mm - 17.2%	EAS 3
S 2140	2	N.v.	Cord	Thread	Thin	Thin	A few mm.	N.v. (EAS 1?)

Table 105. Endband core information.

Catalogue number	E. P. S. type	E. P. S. sewing thread	E. P. S. thread thickness	E. P. S. thread ply	E. P. S. thread twist	Number of tie-downs	Tie-downs position	Thread anchorage
S 0076	N.v.	Hemp (SaS)	Thin	?Z	Loose	As many as Gatherings?	Centre-fold	Uses change-over station
S 0088	Wound plain on 1st core	Hemp waxed (SaS)	Medium	Nk	Medium(?)	As many as Gatherings?	Centre-fold	Uses change-over station
S 0426	Wound plain on 1st core	Linen	Thin	double 2S	Tight	N.k.	Centre-fold	Uses other passing hole outside
S 0433	Wound plain on 1st core ?	Linen waxed	Medium	?Z	Medium?	N.k.	Centre-fold	Uses change-over station
S 0710	Wound plain on core	Hemp	Thick	2S	Loose	N.k.	Centre-fold	NK
S 0764	Wound plain on 1st core ?	Linen	Medium	3Z	Medium	N.k.	Centre-fold	Uses change-over station
S 0931	Wound plain on core	Linen	Thin	3S	Medium	N.k.	Centre-fold	Uses change-over station
S 1768	Wound plain on 1st core	Linen (SaS)	Thin	3?4?Z	Loose	As many as Gatherings	Centre-fold	Uses change-over station
S 1814	Wound plain on core	Linen (SaS)	Thin	2 2s Z	Tight	As many as Gatherings	Centre-fold	Uses change-over station
S 1856	Wound plain on 1st core	Linen	Medium	2Z	Loose	N.k.	Centre-fold	Uses change-over station
S 1996	Wound plain on core	Linen (SaS)	Thin	?Z	Tight	As many as Gatherings	Centre-fold	Uses change-over station
S 2056	Wound plain on core	Linen (SaS)	Thin	2S	Medium	As many as Gatherings	Centre-fold	Uses change-over station
S 2140	N.v.	Cotton (?) (SaS)	Medium	2 2s Z	Medium	As many as Gatherings	Centre-fold	Uses change-over station

Table 106. Endband primary sewing type.

Catalogue number	Endband secondary sewing (E. S. S.) type	E. S. S. thread	E. S. S. threads colour/s	E. S. S. thread thickness	E. S. S. thread ply	E. S. S. thread twist
S 0076	2-core Chevron & crowning core (3 colours)	Silk	Cyan, pink, white	Fine	?S	Tight
S 0088	2-core Chevron & crowning core (3 Colours)	Silk	Cyan, yellow, red	Fine	2Z?	Tight
S 0426	2-core Chevron & crowning core (3 colours)	Silk	Cyan, yellow, pink	Fine	2S	Tight
S 0433	2-core Chevron & crowning core (4 colours)	Silk	Green (2 hues), pink, white	Fine	2S	Tight
S 0710	None	-	-	-	-	-
S 0764	2-core Chevron & crowning core (2[H], 3[B] colours)	Silk	Pink, white (H), Cyan, pink, white (T)	Fine	2S	Tight
S 0931	Cretan on single warps (2 colours)	Silk / linen?	Green, pink / natural	Fine / medium	2S / N.k.	Medium / N.k.
S 1768	Embroidered, front bead & crowning core (2 colours)	Silk, wool	Red, white	Medium	Unclear	Loose?
S 1814	Cretan on single warps (2 colours)	Silk / Silk?	Cyan, white / black and white	Fine / Fine	N.k. / N.k.	N.k. / N.k.
S 1856	2-core Chevron & crowning core (5 colours)	Silk	Cyan, yellow, red, pink, white	Fine	S	Tight
S 1996	Cretan on single warps (only warps are left)	N.k. / Linen	N.k. / natural	- / Medium	- / N.k.	- / N.k.
S 2056	Missing. Only vestiges (2 colours)	Silk	Yellow, pink (?)	Fine	2S?	Tight?
S 2140	Embroidered, front bead & crowning core (2 colours)	Cotton ?(S. a. S.)	Blue, white	Fine	N.k.	N.k.

Table 107. Endband secondary sewing information.

Catalogue number	Marker	Primary marker	Primary marker material & colour	Primary Marker way of attachment	Secondary marker	Secondary marker material & color	Secondary M way of attachment
S 0076	Compound	Unclear (only vestiges)	Pink silk (vestiges)	N.k.	1 single string	Black cotton	Pli
S 0088	Compound	Unclear (obscured by secondary marker)	Natural cotton (?) thread	LtH(f)	Various threads	Natural linen	Unclear
S 0426	Compound	1 compound closed loop F (partly missing)	Twisted leather core / cyan silk	LtH(f)	N.k. (missing)	1 green silk, 2 yellow + pink silk ribbons	KiE, KiE
S 0433	Compound	1 compound closed loop F	Cord (?) core / green silk	LtH(f)	3 ribbons	-	-
S 0710	None	-	-	-	-	-	-
S 0764	None	-	-	-	-	-	-
S 0931	Compound	Unclear (only vestiges)	Silk same as endband	LtH(f)	N.k. (missing)	-	-
S 1768	None	-	-	-	-	-	-
S 1814	Compound	1 compound closed loop F	Double sewing thread / yellow silk	LtH(f)	1 single string	Yellow Silk	KiE ?(now detached)
S 1856	Compound	1 compound closed loop F	Double sewing thread / cyan silk	LtH(d) ?	N.k. (missing)	-	-
S 1996	None	-	-	-	-	-	-
S 2056	None	-	-	-	-	-	-
S 2140	None	-	-	-	-	-	-

Table 108. Markers information.

Catalogue number	Cover material	Cover colour/tone	Turn-ins type	Turn-ins width	Corner mitre
S 0076	Goat? leather	Brown	T-ins 3	Varies	Varies
S 0088	Goat leather	Red-brown	T-ins 2	Medium	Co 2, Co 3
S 0426	Goat leather	Yellow-brown	T-ins 3	Medium	Not visible
S 0433	Goat leather	Bright red	T-ins 2 (?)	Medium	Co 2, Co 3
S 0710	N.k. leather	Yellow-brown	T-ins 3	Varies	Varies
S 0764	Goat? leather	Brown	T-ins 3	Varies	N.v.
S 0931	Goat? leather	Yellow-brown	T-ins 1, T-ins 3	Varies	Co 2
S 1768	N.k. leather	Light brown	T-ins 3	Narrow	Co 1
S 1814	Goat leather	Yellow-brown	T-ins 3	Medium	Varies
S 1856	Goat? leather	Yellow-brown	T-ins 3	Varies	Co 2
S 1996	N.k. leather	Light brown	T-ins 2	Narrow	Co 6
S 2056	Goat? leather	Black	T-ins 3	Varies	Co 2
S 2140	Goat? leather	Yellow-brown	T-ins 2	Narrow	Co 2, Co 3

Table 109. Cover information.

Catalogue number	Left / Right difference?	Decoration patterns	Spine decoration pattern	Board edges decoration pattern	Decoration tools	Number of tools
S 0076	Yes	Dec3a(L), Dec2a(R)	SD2/B	None (Some attempts in the endbands areas)	MuF/d25, fillets	2
S 0088	No	Dec2a	SD2/B	None	MuA/b5, fillets	2
S 0426	No	Dec2a	SD1/B	None	MuA/b5, fillets	2
S 0433	No	Dec1abcd	No	BED 5	MuA/b5, RoF/40, fillets	3
S 0710	No	Dec3a	Nk	None	MuA/b5, fillets	2
S 0764	No	Dec2abc	No	BED 5	MuA/b5, fillets	2
S 0931	No	Dec3a	No	None	MuA/b5, fillets	2
S 1768	No	Dec2ab	No	None	MuA/b5, RoF/43, MuF/a59, fillets	4
S 1814	No	Dec2a	SD2/B	None	MuA/b5, fillets	2
S 1856	Yes	Dec3ab(R), Dec1ab(L)	No	None	MuA/b5, MuF/d25, fillets	3
S 1996	No	Dec3a	SD2/B	None	MuA/b5, fillets	2
S 2056	Yes	Dec2a(L), Dec1ab(R)	SD2/B	None	MuF/d25(?), fillets	2
S 2140	No	Dec11a	No	None	MuF/d25, MuF/a60, RoF/41, fillets	4

Table 110. Decoration information.

Tool	Volumes where it is used	Number of volumes where it is used
MuA/b5	All except S. 76, S. 2056, S. 2140	10
MuF/d25	S. 76, S. 1856, S. 2056, S. 2140	4
RoF40	S. 433	1
RoF41	S. 2140	1
RoF43	S. 1768	1
MuF/a59	S. 1768	1
MuF/a60	S. 2140	1
Fillets	All	13

Table 111. Tools information.



Catalogue number	Edge decoration	Colour
S 0076	Painted all over	Green now badly flaked
S 0088	None	-
S 0426	Painted all over	Green
S 0433	Drawn complex floral motifs	Red
S 0710	None	-
S 0764	None	-
S 0931	None	-
S 1768	None	-
S 1814	None	-
S 1856	Drawn and painted floral motifs	Black, red
S 1996	None	-
S 2056	None	-
S 2140	None	-

Table 112. Text-block edges decoration information.

Catalogue number	Number of fastenings	Fastenings type	Fastenings material	Strap anchorage type	Fastenings & T-ins arrangement	Ends form	Arrangement of anchorage holes	Format of text-block	Thickness of text-block	Metal components
S 0076	0-1-0 ←	Three edged leather interlaced strap / Long hinge	SaC and metal	TBT	F & T 1	UuP	AH 4	8vo	41	Ring & filed metal simple pin
S 0088	0-1-0 ←	Three edged leather interlaced strap / N.k.	Missing	TBT	F & T 1	Nk (missing)	AH 4	8vo	30	Ring ?(M) & filled simple metal pin
S 0426	0-2-0 ←	Three edged leather interlaced straps / Standard	SaC and metal	TBTP	F & T 1	UfaP	AH 4	4to	22	Rings & cast metal compound pins
S 0433	0-2-0 ←	Three edged leather interlaced straps / Long hinge	Partly SaC and metal	TBT	F & T 1	? uP	AH 4	4to	36	Rings & cast metal compound pins
S 0710	0-2-0 →←	Leather ties	SaC	TBTP	F & T 1	TbPpPC	AH 5	8vo	18	None
S 0764	0-1-0 ←	Three edged leather interlaced strap / N.k.	SaC and metal	TBTP	F & T 2	UfaP	AH 4	8vo	305	Ring (M) & pin (M) replaced with a nail
S 0931	0-1-0 ←	Three edged leather interlaced strap / Long hinge	SaC and metal	TBTP	F & T 1	UfaP	AH 4	24to	26	Ring & cast and filed metal simple pin
S 1768		None	-	-	-	-	-	8vo	30	None
S 1814	0-2-0 →←	Leather (?) ties	Missing	TBTP	F & T 1	UfaP	AH 1	8vo	28	None
S 1856	0-2-0 ←	Three edged leather interlaced straps / N.k.	SaC and metal	TBTP	F & T 8	UfaP	AH 4	8vo	35	Rings (M) & simple filed metal pins
S 1996	0-1-0 ←	Metal hook & metal catch loop (see photos)	Metal	S Unclear	-	-	Improved	16mo	12	Both components
S 2056	0-1-0 ←	Three edged leather interlaced strap / N.k.	SaC and metal	TBTP	F & T 1	TbPpPC	AH 4	8vo	33	Ring (M) & filed metal simple pin
S 2140	0-2-0 →←	Silk ties (PM)	Silk	TBT	F & T 6	TpaP	AH 1	8o	6	None

Table 113. Fastenings information.

THE NEW LIBRARY BINDINGS

Catalogue Number	Text chronology	Title	Scribe	Format of text-block	Number of leaves	Notes	Original binding?
S. 0403	15th. c.	Homilies by Theodor the Leader of Battalions (T)	N.k.	8vo (278 x 200)	302 WP		No, at least 2nd
S. 1370	18th. c.	Sayings of the fathers (T)	N.k.	8vo (210 x 160)	358 WP / Par		Yes
S. 1461	17th. c.	Music (M)	N.k.	24mo (137 x 90)	197 WP		No, at least 2nd
S. 1464	1323	Stecherarion (M)	N.k.	8vo (270 x 200)	271 EP / WP	f. 270 v. «Επιγράφη η δέλτος αυτή επί έτους στωλα' (6831 AM = 1323 AD) ηνδ. στ.»	No, probably 3rd
S. 1676	18th. c.	Philosophy (O)	N.k.	8vo (210 x 172/163)	332 WpP	f. 330 r. «Εκ των βιβλίων ησαιου ιερομονάχου σναίτου.»	Yes
S. 1701	17th. c.	History of Cosmas Indicopleustis (O)	N.k.	8vo (210 x 150)	348 WpP		No, at least 2nd
S. 1819	17th. c.-18th. c.	Theological treatises (T)	N.k.	8vo (210 x 162)	329 WP		Yes?
S. 1889	1572 and 18 <sup>th</sup> c. (1 <sup>st</sup> quarter)	Theological treatises (T)	Ioannikios Mitilineos?	16mo (200 x 152)	320 WP		No, at least 2nd
S. 1890	18th. c. (1st quarter)	Theological treatise (T)	Ioannikios Mitilineos?	8vo (212 x 168)	96 WP		Probably yes
S. 1966	1711	Hermologion of St. Catherine (M)	N.k.	8vo (210 x 150)	26 WpP	f. 24 r. «Ετελείθη το παρόν δια χειρός αρχιερέως επί έτους 1711 αρχιερατούντος του μακαριστάτου θειοτάτου τε και μουσικολογιατάτου κωρίου κυρίου αθανασίου». f. 24 v. There is anote bearing the date 1778 29 of july, that actually continues over the paper strips pasted in the spine folds to reinforce them, so the binding should be probably dated before this date.	Probably not
S. 2029	1628	Theotokarion (L)	Filotheos <i>hieromonk</i>	8vo (208 x 147)	245 WP	f. 241 v. «Αμαρτωλού φιλοθέου ιερομονάχου πόνος οι δε αναγινώσκοντες έρωσθε εν καρπίω. έτι απο της ενοάρκου οικονομίας αχη' (1628 AD) αγούστου α.»	No, at least 2nd
S. 2137	1672- 1719	History of the Church (T)	Ioannikios Mitilineos	8vo (220 x 170)	117 WP	f. 65 r. «Εγράφη εν κωνσταντινουπόλει εν τω μετόχιω του αγίου ιωάννου κατά το αψιδ' (1719 AD) φεβρουαρίου γ' δια χειρός ιωαννικίου μυτιληναίου και σναίτου.» f. 108 v. «Γέγραπται εν τω πατριαρχείω της κωνσταντινουπόλεως έν έτει αχρβ' (1672) μηνί ιανουαρίου ...»	Yes partly (see sewing notes)
S. A. 0339	14th. c.	St. John Klimacus (T)	N.k.	8vo (210 x 142)	259 WpP	f. 274 r. There is a note in Arab in saying that who ever takes the book away may have the curses of the holy fathers and the archbishop Nikephoros dated 1736	No, at least 2nd
S. A. 0676	1607	Treatises by St. John Chrysostom (T)	N.k.	8vo (212x 153)	129 WpP		No, at least 2nd

Table 114. Text-block information.

Catalogue Number	Original binding?	Date of binding	Type of binding	Binder	Binder's note
S. 0403	No, at least 2nd	1733	Projecting pasteboards with supports	Ioannikios Rhodios	<b>Left flyleaf.</b> «Μετασταχώθη η παρούσα βιβλος επι έτους αψλγ (1733 AD) δια συνδρομής και επιστασίας του πανιερωτάτου αρχιεπισκόπου Σινά όρους κυρίου νικηφόρου, επιμελεία και κόπω Ιωαννικίου Ιερομονάχου ροδίου ο δε κύριος δώη αυτοίς τον μισθόν της προθυμίας».
S. 1370	Yes	N.k.	Projecting pasteboards with supports	N.k.	
S. 1461	No, at least 2nd	N.k.	Projecting pasteboards with supports	N.k.	
S. 1464	No, probably 3rd	N.k.	Flush pasteboards with supports	N.k.	<b>f. 270 v.</b> «Το παρόν στηγριφάριον υπάρχη εμού νικηφόρου ιερομονάχου κρητός του μαρθάλη και μετά πολλού κόπου ευνένδεσα αυτό κατά τω αψ (1700 AD) σ(ωτή)ριον έτος και οι κατά καιρόν μοθηκείζων[τα]ες εν [...].»
S. 1676	Yes	N.k.	Projecting pasteboards with supports	N.k.	
S. 1701	No, at least 2nd	1733	Projecting pasteboards with supports	Ioannikios Rhodios	<b>Left flyleaf.</b> «Μετασταχώθη το παρόν επι έτους αψλγ (1733 AD) δια συνδρομής και επιστασίας του πανιερωτάτου αρχιεπισκόπου Σινά όρους κυρίου νικηφόρου, επιμελεία και κόπω Ιωαννικίου Ιερομονάχου ροδίου ο δε κύριος δώη αυτοίς τον μισθόν της προθυμίας».
S. 1819	Yes?	N.k.	Projecting pasteboards with supports	N.k.	
S. 1889	No, at least 2nd	N.k.	Projecting pasteboards with supports	N.k.	
S. 1890	Yes ?	N.k.	Projecting pasteboards with supports	N.k.	
S. 1966	Probably not	1711?	Flush pasteboard with supports	N.k.	
S. 2029	No, at least 2nd	N.k.	Projecting pasteboards with supports	N.k.	
S. 2137	Yes partly	1719?	Projecting pasteboards with supports	N.k.	
S. A. 0339	No, at least 2nd	N.k.	Projecting pasteboards with supports	Monk Raphael	<b>f. 3r.</b> «μετεσταχώθη το παρόν υπό ραφαήλ μοναχού και υπάρχη του αγίου μοναστηρίου όρους σινά , και ουδείς τομήσει αποξενώσει αυτό εν βάρει αλότου αφορισμού + ο Επάλιου (?) Κύριλλ(ος)»
S. A. 0676	No, at least 2nd	N.k.	Projecting pasteboards with supports	N.k.	

**Table 115. Binding information.**

Catalogue Number	Original binding?	Spine-fold repair type and material	Text-block repair type and material
S. 0403	No, at least 2nd	Paper strips pasted locally in the inside the spine-fold of the central bifolio of some gatherings	Paper strips pasted locally in some leaves.
S. 1370	Yes	-	Very few paper strips pasted in the edges of some leave
S. 1461	No, at least 2nd	Paper strips pasted all-along the spine-folds in some gatherings.	The text-block is badly trimmed cutting off some of the notes in the margins
S. 1464	No, probably 3rd	Parchment & paper strips pasted locally in the spine-folds of some gatherings and more paper cuttings pasted above them (latter repair?)	Some paper strips pasted in the edges of some leaves at both ends of the text-block
S. 1676	Yes	-	-
S. 1701	No, at least 2nd	-	-
S. 1819	Yes?	-	-
S. 1889	No, at least 2nd	Paper strips pasted on single, conjugate leaves in order to turn them into bifolia . In the outermost gatherings	-
S. 1890	Yes ?	-	-
S. 1966	Probably not	Paper strips pasted all-along the spine-folds of some gatherings	-
S. 2029	No at least 2nd	-	-
S. 2137	Yes partly	Paper strips pasted in the spine-folds of the older (1672) gatherings.	-
S. A. 0339	No, at least 2nd	Paper strips pasted all-along the spine-folds of some of the outermost gatherings	-
S. A. 0676	No, at least 2nd	Very few paper strips pasted in the spine-folds of some gatherings	-

**Table 116. Repair information.**

Catalogue Number	Original binding?	Left endleaf arrangement	Right endleaf arrangement
S. 0403	No, at least 2 <sup>nd</sup>	[1] 1	1 [1]
S. 1370	Yes	[1] 3+8+	5 [1]
S. 1461	No, at least 2 <sup>nd</sup>	[2] f A+	+ A f [2]
S. 1464	No, probably 3rd	[1] 1	1? [1]
S. 1676	Yes	[1] 3	3 [1]
S. 1701	No, at least 2 <sup>nd</sup>	[1/3, 1] 1f/	\ n [1, 1/3]
S. 1819	Yes?	[1] 1	? [1]?
S. 1889	No, at least 2 <sup>nd</sup>	[1] 7	7 [1]
S. 1890	Yes?	[1] 3+	3 [1]
S. 1966	Probably not	[1] 1+	+ \ p [1]
S. 2029	No at least 2 <sup>nd</sup>	[1] 2+	+ [1]
S. 2137	Yes partly	[1] 3	+ 2 [1]
S. A. 0339	No, at least 2 <sup>nd</sup>	[1] 1	1 [1]
S. A. 0676	No, at least 2 <sup>nd</sup>	N.k. (Missing)	+ [1]

Table 117. Endleaf units arrangement information.

Catalogue Number	Number of sewing stations	Distance between stations/ pattern of sewing stations	Kind of Sewing	Accommodation nicks	Sewing notes	Thickness of text-block	Format of text-block
S. 0403	6	12-23-65-67-62-20-24 / B4B6	Supported	Needle holes		42	8vo
S. 1370	4	23-26-112-23-28 / B4C3	Supported	Needle holes		60	8vo
S. 1461	4	25-20-50-22-18 / B6C3	Supported	Needle holes		34	24mo
S. 1464	6	22-16-57-70-63-13-21 / C4	Supported	Needle holes?		70	8vo
S. 1676	5	24-24-60-65-15-20 / B6C3	Supported	Needle holes		42	8vo
S. 1701	4	20-55-55-54-23 / B1	Supported	Needle holes	Change over stations are also supported	40	8vo
S. 1819	5	20-20-65-65-20-25 / B6C3	Supported	Needle holes		45	8vo
S. 1889	5	22-24-53-51-25-18 / B4C3	Supported	Needle holes	Apparently supports are cut flush with the spine of the text-block and the connection with the text-block is made through cord (see drawings). The same or similar is found in S. 2029.	41	16mo
S. 1890	4	26-34-85-35-28 / B2	Supported	Needle holes	There is evidence that the text-block had a preliminary sewing since there appears an unused hole in the middle of gatherings	13	8vo
S. 1966	5	20-27-58-57-25-25 / B4B6	Supported	Needle holes	Measures of Distances between stations may not be accurate mostly in the outermost panels due to bad preservation.	7	8vo
S. 2029	7	20-15-35-35-34-35-14-18 / C3	Supported	Needle holes		38	8vo
S. 2137	5	23-21-66-65-22-21 / B6C3	Supported	Needle holes	In the second older text-block written in 1672 there are sewing holes left unused, probably due to a former binding. It is also the fact that spine folds are reinforced all through with paper strips.	17	8vo
S. A. 0339	5	15-16-72-73-16-16 / B6	Supported	Tiny V-shaped cuts		35	8vo
S. A. 0676	4	30-33-91-32-37 / B6C3	Supported	Needle holes	There are 2 holes in each support for the sewing thread. The thread comes out of the gathering from one hole and enters from an other.	20	8vo

Table 118. Sewing information.

Catalogue Number	Sewing thread	Sewing thread thickness	Sewing thread twist	Sewing thread ply	Supports number	Supports material	Supports thickness
S. 0403	Linen	Thin	Medium	S	1-1-1-1	Cord	Medium
S. 1370	Linen	Thin	Medium	2S	1-1	Cord	Medium
S. 1461	Hemp	Thin	Loose	?S	1-1	Cord	Medium
S. 1464	Hemp	Thin	Loose	2S	1-1-1-1	Cord	Medium
S. 1676	Linen	Thin	Medium	2Z	1-1-1	Cord?	Medium
S. 1701	Linen	Thin	Medium	2S	1-1-1-1	Cord	Thick
S. 1819	Hemp	Medium	Loose	S	1-1-1	Cord	Medium
S. 1889	Hemp	Medium	Loose	2S	1-1-1	Leather thong	Medium
S. 1890	Linen	Thin	Medium	?S	1-1	Cord	Medium
S. 1966	Hemp?	Thin	Loose	?S	1-1-1	Cord	Medium
S. 2029	Hemp	Extra thin	Loose	S	LI-LCI-LI-LCI-LI	Cord./ leather thong	Medium/medium
S. 2137	Hemp	Medium	Medium	?S	1-1-1	Cord?	Medium
S. A. 0339	Hemp	Medium	Loose	2Z	1-1-1	Leather thong?	Thick
S. A. 0676	Hemp	Medium	Loose	2S	1-1	Cord	Medium

Table 119. Sewing thread and supports information.

Catalogue Number	Attachment system	Material	Dimensions	Spine edge treatment	Spine joints	Thickness of boards	Thickness of text-block	Format of text-block
S. 0403	N.v.	Pasteboards	Projecting	SET 1	None	5	42	8vo
S. 1370	Sup 5	Pasteboards	Projecting	SET 1	None	3-4	60	8vo
S. 1461	Sup 7	Pasteboards	Projecting	SET 1	None	4	34	24mo
S. 1464	Sup 5	Pasteboards	Flush	SET 1	Slight	5	70	8vo
S. 1676	Sup 5?	Pasteboards	Projecting	SET 1	None	4	42	8vo
S. 1701	Sup 7?	Pasteboards	Projecting	SET 1	None	4	40	8vo
S. 1819	Sup 4	Pasteboards	Projecting	SET 1	None	5	45	8vo
S. 1889	Unclear	Pasteboards	Projecting in HE & TE	SET 1	None	3	41	16mo
S. 1890	Sup 5	Pasteboards	Projecting in HE & TE	SET 1	None	3	13	8vo
S. 1966	Sup 5?	Pasteboards, Paper MS	Flush	SET 1	None	3	7	8vo
S. 2029	Sup 4	Pasteboards	Projecting	SET 1	Slight	4	38	8vo
S. 2137	Sup 5	Pasteboards	Projecting in HE & TE	SET 1	None	3	17	8vo
S. A. 0339	Unclear (Sup 4? Sup 5?)	Pasteboards	Projecting	SET 1	None	4	35	8vo
S. A. 0676	Unclear (Sup 3 or Sup 5)	Pasteboards	Projecting	SET 1	None	5	20	8vo

Table 120. Boards information.

Catalogue Number	Spine lining	Material	Thickness	Board covered	Side of boards covered	Spine shape	Thickness of text-block
S. 0403	Yes, all along the spine	Canvas	Medium	N.k.	Outside	Round	42
S. 1370	Yes, all along the spine	Canvas	Thick	50%	Outside	Flat	60
S. 1461	Yes, all along the spine	Canvas	Thin	N.k.	Outside	Slight round	34
S. 1464	Yes, all along the spine	Canvas	Medium	20%	Outside	Heavy round	70
S. 1676	Yes, all along the spine	Canvas	Medium	N.k.	Outside	Flat	42
S. 1701	Yes, all along the spine	Canvas	Thin	N.k.	Outside	Flat	40
S. 1819	Yes, all along the spine	Canvas	Medium	N.k.	Outside	Flat	45
S. 1889	Yes, all along the spine	Canvas	Medium	N.k.	Outside	Round	41
S. 1890	Yes, all along the spine	Canvas	Medium	65%	Outside	Flat	13
S. 1966	Yes, all along the spine	Blue canvas	Thick	30%?	Outside	Flat	7
S. 2029	Yes, all along the spine	Canvas	Thick	N.k.	Outside	Slight round	38
S. 2137	Yes, all along the spine	Canvas	Medium	N.k.	Outside	Flat	17
S. A. 0339	Yes, all along the spine	Blue canvas	Thick	30%	Outside	Slight round	35
S. A. 0676	Yes, all along the spine	Red canvas	Medium	N.k.	Outside	Flat	20

Table 121. Spine lining information.

Catalogue Number	Number of cores	Endband primary sewing (E. P. S.) type	First core material	Second core material	Third core material	First core thickness	Second core thickness	Third core thickness	Distance of projection	Anchoring system
S. 0403	2	Wound plain on 1st core?	Cord	Thread	-	Medium	Thin	-	16 mm - 8%	EAS 13
S. 1370	2	N.v.	Cord?	Thread	-	Medium	Thin	-	8 mm - 5%	EAS 9
S. 1461	2	Embroidered, front bead & crowning core (2 colours)	Cord	Thread	-	Thin	Thin	-	12 mm - 13%	EAS 9
S. 1464	2	N.v.	Cord	Cord	-	Medium	Medium	-	N.k.	EAS 9
S. 1676	3	N.v.	N.v.	Cord	Cord	Medium	Medium	Medium	10 mm - 5,8%	EAS 9
S. 1701	2	Wound plain on 1st core?	Cord	Cord	-	Thick	Medium	-	17 mm - 11,3%	EAS 9
S. 1819	3	Wound plain on 1st core?	Cord	Cord	Cord	Medium	Medium	Medium	13 mm - 8%	EAS 9
S. 1889	2	N.v.	Cord	Thread	-	Medium	Thin	-	6 mm - 3,9%	EAS 9
S. 1890	2	N.v.	Cord	Thread	-	Medium	Thin	-	7 mm - 4,1%	EAS 9
S. 1966	1	Wound plain on 1st core?	Cord	-	-	Medium	-	-	9 mm - 6%	EAS 3
S. 2029	2	Wound plain on 1st core?	Cord	Thread	-	Thick	Thin	-	8 mm - 5,4%	N.k.
S. 2137	2	N.v.	Cord	Thread	-	Medium	Thin	-	5 mm - 2,9%	EAS 9
S. A. 0339	2	Wound plain on 1st core	Cord?	Thread?	-	Thick	Thin	-	7 mm - 4,9%	EAS 9
S. A. 0676	2	Wound plain on 1st core?	Cord	Thread	-	Medium	Thin	-	18 mm - 11,7%	EAS 9

Table 122. Endband cores information.

Catalogue Number	Endband primary sewing (E. P. S.) type	E. P. S. sewing thread	E. P. S. thread thickness	E. P. S. thread ply	E. P. S. twist	Number of tie-downs	Tie-downs position	Thread anchorage
S. 0403	Wound plain on 1st core?	Linen	Thin	S	Medium	N.k.	Centre-fold	Uses change-over station
S. 1370	N.v.	Linen SaS	Thin	2S	Medium	Every gathering	Centre-fold	Uses change-over station
S. 1461	Embroidered, front bead & crowning core (2 colours)	Silk red, yellow	Thin	I?	Loose	None	-	No tie-downs, sewn on spine lining?
S. 1464	N.v.	Hemp	Thin	2S	Loose	N.k.	Centre-fold	Uses change-over station
S. 1676	N.v.	N.k.	N.k.	N.k.	N.k.	N.k.	N.k.	N.k.
S. 1701	Wound plain on 1st core?	Linen SaS	Thin	2S	Medium	Less than gatherings	Centre-fold	Uses change-over station
S. 1819	Wound plain on 1st core?	Linen bleached	Thin	Z	Tight	N.k.	Centre-fold	Uses outermost main sewing stations
S. 1889	N.v.	Linen	Thin	2Z	Loose	Every gathering	Centre-fold	Uses change-over station
S. 1890	N.v.	Linen SaS	Thin	?S	Medium	Every gathering	Centre-fold	Uses change-over station
S. 1966	Wound plain on 1st core?	Linen SaS	Thin	2S	Loose	Every gathering	Centre-fold	Uses change-over station
S. 2029	Wound plain on 1st core?	Linen	Thin	S	Loose	N.k.	Centre-fold	Uses change-over station
S. 2137	N.v.	Hemp SaS	Medium	?S	Medium	Every gathering	Centre-fold	Uses change-over station
S. A. 0339	Wound plain on 1st core	Hemp	Medium	2S	Loose	Every gathering	Centre-fold	Uses change-over station
S. A. 0676	Wound plain on 1st core?	Hemp SaS	Medium	2S	Loose	Every gathering	Centre-fold	Uses change-over station

Table 123. Endband primary sewing information.

Catalogue Number	Endband secondary sewing (E. S. S.) type	E. S. S. thread	E. S. S. colours	E. S. S. thread thickness	E. S. S. thread ply	E. S. S. thread twist
S. 0403	Embroidered front bead & crowning core (2 colours)	Silk	Yellow, red	Medium	I?	Loose
S. 1370	Embroidered front bead & crowning core (2 colours)	Silk	Bright yellow, green	Medium	I	Loose
S. 1461	None	-	-	-	-	-
S. 1464	Embroidered front bead & crowning core (2 colours)	Silk	Cyan, magenta (HB), Yellow, magenta (TB)	Medium	N.k.	Loose
S. 1676	Chevron & crowning core (2 colours)	Silk	Blue, red	Medium	2(?)S	Loose
S. 1701	Embroidered front bead & crowning core (2 colours)	Silk	Yellow, red	Medium	I?	Loose
S. 1819	Chevron & crowning core (2 colours)	Silk	Green, red	Medium	S	Loose
S. 1889	Embroidered front bead & crowning core (2 colours)	Silk	Yellow, red	Medium	I?	Loose
S. 1890	Embroidered front bead & crowning core (2 colours)	Silk	Yellow, pink (both faded)	Medium	I?	Loose
S. 1966	Wound plain on primary sewing (1 colour)	Silk?	Blue (faded)	Medium	N.k.	N.k.
S. 2029	Embroidered front bead & crowning core (2 colours)	Silk	Yellow, red (HB), Red, red+violet (TB)	Medium	I?	Loose
S. 2137	Embroidered front bead & crowning core (2 colours)	Silk	Yellow, green	Medium	I?	Loose
S. A. 0339	Embroidered front bead & crowning core (2 colours)	Silk	Green, red	Medium	2S	Loose
S. A. 0676	Embroidered front bead & crowning core (2 colours)	Silk	Yellow, blue	Medium	N.k.	Loose

Table 124. Endband secondary sewing information.

Catalogue Number	Marker	Primary marker	Primary M material & colour	Primary M way of attachment	Secondary marker	Secondary M material & colour	Secondary M way of attachment
S. 0403	None	-	-	-	-	-	-
S. 1370	None	-	-	-	-	-	-
S. 1461	Compound	One simple open loop	Yellow silk (SaE)	LtH(f)	Missing	Yellow silk	N.k. (only vestiges)
S. 1464	Compound	Five simple open loops	Cyan silk (SaE)	LtH(a)	Missing	Missing	Missing
S. 1676	None	-	-	-	-	-	-
S. 1701	None	-	-	-	-	-	-
S. 1819	Compound	One compound open loop feather stitched	?cord & green silk (SaE)	LtH(f)	Missing	Missing	Missing
S. 1889	None	-	-	-	-	-	-
S. 1890	None	-	-	-	-	-	-
S. 1966	None	-	-	-	-	-	-
S. 2029	Compound	One simple open loop	Red, yellow silk (SaE)	LtH(f)	Missing	Missing	Missing
S. 2137	None	-	-	-	-	-	-
S. A. 0339	Compound	One simple closed loop	Green silk (SaE)	LtH(f)	Simple string	Whitish linen	KiM
S. A. 0676	None	-	-	-	-	-	-

Table 125. Markers information.

Catalogue Number	Cover material type	Cover colour/tone	Turn-ins type	Turn-ins width	Corners mitre
S. 0403	Sheep?	Yellow-brown	T-ins3	Varies	Varies
S. 1370	Sheep?	Yellow-brown	T-ins 3	Medium-wide	Co 2
S. 1461	Sheep?	Brown	T-ins 3	Varies	Co 2
S. 1464	Goat?	Brown	T-ins3	Medium	Co 3, Co 4
S. 1676	Sheep?	Ochre	T-ins 3	Wide	Varies
S. 1701	Goat?	Red-brown	T-ins 1, T-ins 3	Medium	Co2, Co 3
S. 1819	Goat	Yellow-brown	T-ins3	Varies	Varies
S. 1889	Goat	Yellow-brown	T-ins 2	Medium	Co 5, Co14
S. 1890	Goat	Yellow-brown	T-ins 2	Medium	Co 2, Co 3
S. 1966	Goat?	Black	T-ins 2	Narrow	Co 7, Co 6
S. 2029	Goat?	Yellow-brown	T-ins 2	Medium	Co 1, Co 2
S. 2137	Goat?	Yellow-brown	T-ins 2	Medium	Co 2, Co 3
S. A. 0339	Goat?	Yellow-brown	T-ins 3	Medium	Varies
S. A. 0676	Goat	Red-brown	T-ins 2	Narrow	Co2

Table 126. Cover information.



Catalogue Number	Decoration patterns	Spine decoration schema	Decoration motifs	Number of tools used
S. 0403	Decla	SD2/B	CeF57, CeR6, RoF7, fillets	4
S. 1370	Decl	SD1/B	MuF/b8, MuV1, CeF2, CeF57, fillets	5
S. 1461	Decla	SD2/B	MuV1, RoF7, fillets	3
S. 1464	Decla?	SD2/B	CeF57, CeR16, RoF7, fillets	4
S. 1676	Decla	None	MuF/b8, CeF2, CeF57, RoF42, fillets	5
S. 1701	Decla	SD1/B	MuV1, CeF57, RoF7, fillets	4
S. 1819	Decla	None	MuF/b8, CeR1, RoF7, fillets	4
S. 1889	Decl	SD2/B	MuF/b8, CeF2, CeF42, fillets	4
S. 1890	Decl	SD2/B	MuF/b8, CeF2, CeF42, fillets	4
S. 1966	Other	None	MuF/b8, fillets	2
S. 2029	Decla	None	CeF2, CeR16, fillets	3
S. 2137	Decla	SD2/B	CeF42, CeF47, fillets	3
S. A. 0339	Dec2	SD2/B	MuF/b8, fillets	2
S. A. 0676	Decla	SD2/B	MuF/a54, MuF/a55, MuF/b8, fillets	4

Table 127. Decoration information.

Tool	Volumes where it is used	Number of volumes where it is used
MuF/a54	S. A. 676	1
MuF/a55	S. A. 676	1
MuF/b8	S. 1370, S. 1676, S. 1819, S. 1889, S. 1890, S. 1966, S. A. 339, S. A. 676	8
MuV1	S. 1370, S. 1461, S. 1701	3
CeF2	S. 1370, S. 1676, S. 1889, S. 1890	4
CeF42	S. 1889, S. 1890, S. 2137	3
CeF47	S. 2137	1
CeF57	S. 403, S. 1370, S. 1464, S. 1676, S. 1701	5
CeR1	S. 1819	1
CeR6	S. 403	1
CeR16	S. 1464, S. 2029	3
RoF7	S. 403, S. 1461, S. 1464	1
RoF42	S. 1676	1
Fillets	All volumes	14

Table 128. Tools information.

Catalogue Number	Number of fastenings	Fastenings type	Fastenings material	Anchorage type	Turn-ins disposition	Ends form	Disposition of anchorage holes	Format of text-block	Thickness of text-block
S. 0403	0	None	-	-	-	-	-	8vo	42
S. 1370	0	None	-	-	-	-	-	8vo	60
S. 1461	0	None	-	-	-	-	-	24mo	34
S. 1464	0	None	-	-	-	-	-	8vo	70
S. 1676	0	None	-	-	-	-	-	8vo	42
S. 1701	0	None	-	-	-	-	-	8vo	40
S. 1819	0-2-0 →←	Thin leather straps	SaC	TBTP	-	TbPpPC	AH I	8vo	45
S. 1889	0	None	-	-	-	-	-	16mo	41
S. 1890	0	None	-	-	-	-	-	8vo	13
S. 1966	0	None	-	-	-	-	-	8vo	7
S. 2029	0	None	-	-	-	-	-	8vo	38
S. 2137	0	None	-	-	-	-	-	8vo	17
S. A. 0339	0	None	-	-	-	-	-	8vo	35
S. A. 0676	0	None	-	-	-	-	-	8vo	20

Table 129. Fastenings information.

THE IVIRON SCRIPTORIUM BINDINGS

Catalogue Number	Text chronology	Title	Scribe/s	Format of text-block	Number of leaves	Notes	Original binding?
I. 0042	14th c. & 1525	Triodion (L)	Hosios Theophilos (partly)	8o (208 x 268)	177 Par/WP	-	No, at least 2nd
I. 0046	1007	St. John Chrysostom commentary on St. Mathew Gospel (T)	Monk Theophanis	Folio (385 x 310)	307 Par	f. 304 v. « Ετελειώθη η παρόνσα βιβλος μηνί φεβρουαρίω τνδ. ε' έτει σφιε' (6515 AM = 1007) γραφείσα χειρί Θεοφάνους ταπεινού μοναχού ».	No, at least 2nd
I. 0258	13th c.	St. John Chrysostom speeches on the Genesis (T)		Folio (420 x 300)	340 WP	-	No
I. 0392	1534	Miscellaneous -24 texts. (T & L)	Dionisios proigumenos	8vo (220 x 152)	696 WP	f. 689 v - 693 γ. «...Ετελειώθη το παρόν βιβλίον ...εμοῦ του ευτελους Διονυσίου Ιερομονάχου...έτους ζμβ' (7042 AM = 1534 AD). ...εν τω...βασίλική μονή των Ιβήρων...»	Yes
I. 0436	1512/13	Saints lives (T)	Hosios Theophilos	4to (311 x 212)	497 WP	f. 495 γ. «Εγράφει το δε εν έτει ζκα' (7021 AM = 1513 AD) τνδ. Α' τω πρώτω έτει της αυταρχίας η τυραννίδος του Σουλτάν Σάλεμ του Οσμάν. Του ευτελους Θεοδοσιου θύτου τάλανος τάχα και ρακενδύτου.»	Yes
I. 0528	1538	Euchologion (L)	Hosios Theophilos	8vo (235 x 73)	403 WP	f. 400 γ. «...ετελειώθει κατά μήνα σεπτέμβριον και έτος ζιζ' (7047 AM = 1538 AD) και ανετέθη τη παντανάσση κυρία μου Θ(εοδ)κον τη πορταίωση τη κεκλημένη μονή των Ιβήρων εν τω του άθωνος όρει ...»	Yes
I. 0581	1523	Saints Lives (T)	Hosios Theophilos	Folio (412 x 273)	292 WP	f. 289 v. « Η βιβλος έσχεν ηδε συν θεώ πέρας πόνω θεοφιλου τάλανος ρακενδύτου μηνί Ιανουαρίω εν έτει ζα' (7031 AM = 1523 AD) ...»	No, at least 2nd
I. 0593	1540	Saints lives and other texts (T)	Pahomios Rousanos	4to (350 x 245)	302 WP	f. 301 v. «Τα γραφέντα υπέρ ημων βιβλία εν τη των Ιβήρων ευαρεστάτη μονή. Γένεσις. Ευαγγέλια εωθινά... Έπι διαθήκη και τυπικόν του οσιου Αθανασίου. Έτους ζμη' (7048 AM = 1540 AD)»	Yes
I. 0697	1533	Miscellaneous -39 texts. (T & L)	Dionisios proigumenos	16mo (156 x 105)	495 WP	f. 427v. « Ετελειώθη η σύνθεσις του παρόντος βιβλιου εν έτη ζια' (7041 AM = 1533 AD) εν μηνί Φεβρου παρ εμοῦ του αμαρτολόυ ιερομονάχου και προηγουμένου εν τη σεβασμία Μονή του τιμίου ενδόξου προφήτου προδρόμου και βαπτιστού Ιωάννου του καθίσματος της σεβασμίας βασιλικής μονής των Ιβήρων της πορταίωσης ... και εύχεσθε μοι δια το Κ(ρηό)ν άπαντες ότι αδαίς εμῆ ».	Yes
I. 0754	16 th c.2nd quarter of	Miscellaneous documents (O)	Pahomios Rousanos	16mo (165 x 127)	211 WP	ff. VIII-V. Various notes by the Proigoumenos Neofitos.	Yes
I. 0783	1542	St. John Chrysostom liturgy (L)	Hosios Theophilos	8vo (230 x 170)	52 WP	f. 47 v. « Θεού το δώρον και θεοφιλου πόνος. Εγράφη εν έτει ζν' (7050 AM = 1542 AD)»	Yes
I. 0810	1536	November Menaion (L)	Theodoros Ariologas	8vo (235 x 165)	255 WP	f. 255 γ. « Έτους ζιδ' (7044 AM = 1536 AD) τνδ. θ' Ιανουαρίου κγ' Θεοδώρου Αριολογά ».	Yes
I. 0837	16 th c. 1st half of	Acolouthies & hymnological (L)	Nikephoros, hosios Theophilos and others	8vo (214 x 140)	428 WP	-	Yes
I. 0907	16 th c.	Miscellaneous liturgical (L)	N.k.	16mo (150 x 100)	597 WP	-	Yes
I. 1585	1540	March Menaion (L)	Neophitos hieromonk	8vo (220 x 160)	254WPP	f. 254 γ. « ... εν μηνί Ιουλιου ιε' του ζμη' (7048 AM = 1450 AD) έτους ... εν τη βασιλική ταύτη μονή των Ιβήρων και ήτις βουληθεί ... »	Yes
I. 1588	1544	Penticostarion (L)	Neophitos hieromonk	8vo (230 x 160)	394 EP?	f. 392 v. «... έπι ζνβ' (7052 AM = 1544 AD) εν μηνί Ιανουαρίω δ'. Θεού το δώρον και νεοφύτου πόνος »	Yes
I. 1589	1538 .	Horologion & Apostolos (L)	Neophitos monk	8vo (240 x 165)	181 WP	f. 2v. « Βιβλίον της Παναγίας θεοτόκου της Πορταίωσης της Ιβηρικής μονής και ήτις τι στερίσει να έχει τας άρας των ... θεοφόρων πατέρων ». f. 120 γ. « Ετελειώθει το παρόν βιβλίον εις ... και χάρτιος και δωρεάς του κυριου ημών Ιησού Χριστού κόπου και δωρεά... .. έτους ζιστ' (7046 AM = 1538 AD ) μηνί Ιουλλίου ιδ' »	Yes

Table 130. Text-block information.

Catalogue Number	Date of Binding	Original binding?	Type of binding	Binder	Notes
I. 0042	1525	No, at least 2nd	Greek style binding	Hioakim hieromonk.	Back pastedown : « Ανεκανίσθη η θεία και ιερά βιβλος εξέμοι αμαρτολό και εντελους Ιωακείμ ιερομονάχου τάχα και πνευματικού και ανετέθη της σεβασμίας και ιεράς βασιλικής μονής των Ιβήρων... Έτους Ζγ' (7033 AM = 1525 AD) ενδ. Γ' εν μηνί μαίω κ' ».
I. 0046	16 <sup>th</sup> c. 1 <sup>st</sup> half	No, at least 2nd	Greek style binding	N.k.	-
I. 0258	16 <sup>th</sup> c. 1 <sup>st</sup> half	No	Greek-style binding	N.k.	-
I. 0392	1534?	Yes	Greek-style binding	N.k.	-
I. 0436	1512/13?	Yes	Greek style binding	N.k.	-
I. 0528	1538	Yes	Greek style binding	N.k.	-
I. 0581	17 <sup>th</sup> ?	No, at least 2nd	Projecting wooden boards with supports	N.k.	Left pastedown: « 1801 εν μηνί Σεπτεμβρίω εμερμετιόθη ως φαίνεται ».
I. 0593	1540 ?	Yes	Greek-style binding	N.k.	-
I. 0697	1533?	Yes	Greek style binding	N.k.	-
I. 0754	16 <sup>th</sup> c. 2 <sup>nd</sup> quarter.	Yes	Flush pasteboard, unsupported binding	N.k.	-
I. 0783	1542?	Yes	Flush pasteboard, unsupported binding with fore-edge flap on the left board	N.k.	-
I. 0810	1536?	Yes	Greek-style binding	N.k.	-
I. 0837	16 <sup>th</sup> c. 1 <sup>st</sup> half ?	Yes	Greek style binding	N.k.	Left pastedown : « Βλέπε ο σταχοτά μη θέσης/ καλώπισε τ(ο) βιβλίον και κόψης αυτών... »
I. 0907	16 <sup>th</sup> c. 1 <sup>st</sup> half ?	Yes	Greek-style binding	N.k.	-
I. 1585	1540?	Yes	Greek-style binding	N.k.	-
I. 1588	1544?	Yes	Greek-style binding	N.k.	-
I. 1589	1538?	Yes	Greek-style binding	N.k.	-

Table 131. Binders information.

Catalogue Number	Original binding?	Spine-fold repairs type and material	Text-block repair type and material
I. 0042	No, at least 2nd	-	-
I. 0046	No, at least 2nd	-	-
I. 0258	No	-	Outermost leaves framed with paper strips
I. 0392	Yes	-	-
I. 0436	Yes	Paper strips all along in the first two leaves	-
I. 0528	Yes	-	-
I. 0581	No, at least 2nd	Paper strips all along in the outermost gatherings	Minor paper strips pasted
I. 0593	Yes	Paper strips in the inside of text-block in order to connect loose leaves	Modern paper strips pasted in the last leaf
I. 0697	Yes	-	-
I. 0754	Yes	-	-
I. 0783	Yes	-	-
I. 0810	Yes	-	-
I. 0837	Yes	Paper strips all along in some gatherings.	Minor paper strips pasted
I. 0907	Yes	-	-
I. 1585	Yes	-	-
I. 1588	Yes	Very well done paper strips over pasted in the spine all through or locally	-
I. 1589	Yes	-	-

Table 132. Repair information.

Catalogue Number	Original binding?	Left endleaf arrangement	Right endleaf arrangement
I. 0042	No, at least 2 <sup>nd</sup>	[1] 3	+ 2 [1]
I. 0046	No, at least 2 <sup>nd</sup>	1 +	+ 1
I. 0258	No	[1] ?	+ 1
I. 0392	Yes	4	+ 1
I. 0436	Yes	2 +	5 [1]
I. 0528	Yes	1 +	+ 2
I. 0581	No, at least 2 <sup>nd</sup>	-	-
I. 0593	Yes	3 +	+ [1]
I. 0697	Yes	[?] 4	4 [?]
I. 0754	Yes	5 + (?)	2
I. 0783	Yes	-	-
I. 0810	Yes	?	?
I. 0837	Yes	[1] ?	-
I. 0907	Yes	-	-
I. 1585	Yes	-	-
I. 1588	Yes	[?] 4	2 [?]
I. 1589	Yes	4	8

Table 133. Endleaves information.

Catalogue Number	Number of sewing stations	Distance between stations/ Pattern of sewing stations	Accommodation nicks	Sewing thread	Sewing thread thickness	Sewing thread twist	Sewing thread ply	Format of text-block	Thickness of text-block
I. 0042	5	40-35-75-72-35-28 / B5C6	V-shaped cuts	Hemp	Medium	Loose	2Z	8o	50
I. 0046	7	47-34-52-60-60-52-38-43 / C4	V-shaped cuts	Hemp	Medium	Medium	2 2s Z	Folio	81
I. 0258	5	58-70-83-83-75-53 / B4	V-shaped cuts	Linen	Medium	Medium	2Z	Folio	77
I. 0392	5	25-23-64-63-24-23 / B6	Wide V-shape cuts	Hemp	Medium	Medium	?Z	8vo	100
I. 0436	7	25-25-52-52-50-25-24 / B6	V-shaped cuts	Linen	Thin	Medium	?Z	4to	86
I. 0528	4	28-57-59-60-31 / B1	V-shaped cuts	Hemp	Medium	Loose	2 S	8vo	95
I. 0581	5	23-99-72-76-100-21 / B3	V-shaped cuts	N.k.	N.k.	N.k.	N.k.	Folio	65
I. 0593	5	60-60-59-60-59-54 / A?	V-shaped cuts	Hemp?	Medium	Medium	2S	4to	66
I. 0697	3	25-54-54-23 / B1	V-shaped cuts	Hemp	Medium	Medium	2S	16mo	70
I. 0754	5	21-20-40-40-22-21 / B6	V-shaped cuts	Hemp	Medium	Medium	2S	16mo	29
I. 0783	3	35-75-75-40 / B1	Wide V-shape cuts	Hemp	Medium	Medium	2 S	8vo	20
I. 0810	3	46-76-76-38 / B1	V-shaped cuts	Hemp	Thick	Loose	2S	8vo	43
I. 0837	6	15-35-44-43-35-30-15 / B2?	V-shaped cuts	Linen	Thin	Tight	?S	8vo	74
I. 0907	3	20-55-55-20 / B1	V-shaped cuts	Hemp	Medium	Loose?	2 1 S	16mo	95
I. 1585	5	25-15-65-65-15-30 / C3	Shallow & wide V-shape cuts	Cotton?	Thin	Tight	2 2s Z	8vo	40
I. 1588	5	25-30-60-60-30-25 / B4	V-shaped cuts	Hemp	Medium	Medium	3 1 S	8vo	91
I. 1589	4	30-55-55-57-36 / B1	V-shaped cuts	Hemp	Medium	Loose	2S	8vo	32

Table 134. Sewing information. Red colour indicates the Ivron scriptorium sewing phase.

Catalogue Number	Attachment system	Material	Dimensions	Type of groove	Type of spine edge treatment	Type of attachment primary channel	Spine joints	Thickness of boards	Format of text-block	Thickness of text-block
I. 0042	Uncertain	Hardwood	Flush	BG 2	SET 8	N.k.	Slight	13	8o	50
I. 0046	I Uns/3B ?	Hardwood	Flush	None	SET 4	N.k.	None	17	Folio	81
I. 0258	I Uns/4C ?	Chestnut	Flush	None	SET 4	N.k.	Slight	12	Folio	77
I. 0392	Iviron scriptorium	Hardwood?	Flush	BG 2	SET 4	SER 4	Slight	11	8vo	100
I. 0436	Iviron scriptorium	Hardwood	Flush	BG 2	SET 4	SER 4	120°	14	4to	86
I. 0528	Iviron scriptorium	Hardwood	Flush	BG 2	SET 4	SER 4	Slight	11	8vo	95
I. 0581	-	Hardwood	Flush	BG 2	SET 3	-	120°	11	Folio	65
I. 0593	Iviron scriptorium	Chestnut	Flush	BG 2	SET 4	SER 4	Slight	11	4to	66
I. 0697	-	N.k. (Missing)	-	-	-	-	None	-	16mo	70
I. 0754	I Uns/3A (L) I Uns/1A (R)	Pasteboard, (leather, paper Ms waste and parchment)	Flush	None	SET 1	None	None	3	16mo	29
I. 0783	I Uns/3A	Pasteboard, (oriental paper MS waste)	Flush	None	SET 1	None	None	4-5	8vo	20
I. 0810	Iviron scriptorium	N.k.	-	-	-	SER 4	None	-	8vo	43
I. 0837	I Uns/4B	Hardwood	Flush	BG 2	SET 4	SER 4	Slight	8	8vo	74
I. 0907	Iviron scriptorium	Hardwood	Flush	BG 2	SET 4	SER 4	Slight	9	16mo	95
I. 1585	-	N.k. (Missing)	-	-	-	-	None	-	8vo	40
I. 1588	Iviron scriptorium ?	N.k. (Missing)	-	-	-	-	45°	-	8vo	91
I. 1589	Iviron scriptorium	Hardwood	Flush	BG 2	SET 4	SER 4	Slight	9	8vo	32

Table 135. Boards information.

Catalogue Number	Format of text-block	Spine lining	Number of layers	Material	Thickness	Board covered	Side of boards covered	Spine shape	Thickness of text-block
I. 0042	8o	Yes all along	1	Canvas	Thin	25%	Outside	Slight round	50
I. 0046	Folio	Yes all along	1	Canvas	Medium	N.v.	Outside	Slight round	81
I. 0258	Folio	Yes all along	1	Canvas	Medium	25%	Outside	Slight round	77
I. 0392	8vo	Yes all along	1	Canvas	Thin	N.v.	Outside	Flat	100
I. 0436	4to	Yes all along	1	Canvas	Thin	30%	Outside	Round	86
I. 0528	8vo	Yes all along	1	Canvas	Medium	30%	Outside	Flat	95
I. 0581	Folio	N.k.	N.k.	N.k.	N.k.	N.k.	N.k.	Round	65
I. 0593	4to	Yes all along	1	Canvas	Medium	30%	Outside	Flat	66
I. 0697	16mo	Yes all along	1	Canvas	Medium	20% ?	Outside?	Concave	70
I. 0754	16mo	Yes all along	1	Blue canvas	Thin	30%	Outside	Slight round	29
I. 0783	8vo	Yes all through	1	Canvas	Thin	100%	Outside	Flat	20
I. 0810	8vo	Yes, in head and tail	3	Canvas	Medium	N.v.	Outside?	Slight round	43
I. 0837	8vo	Yes all along	1	Canvas	Thin	100%	Outside	Flat	74
I. 0907	16mo	Yes all along	1	Canvas	Medium	N.v.	Outside	Concave	95
I. 1585	8vo	Yes all along	1	Canvas	Medium	N.v.	N.k.	Concave	40
I. 1588	8vo	Yes all along	1	Canvas	Thin	N.v.	N.k.	Round	91
I. 1589	8vo	Yes all along	1	Canvas	Medium	25%	Outside	Round	32

Table 136. Spine lining information.

Catalogue Number	Number of cores	Endband preliminary sewing	Endband primary sewing (E.P.S.) type	First core material	Second core material	Third core material	First core thickness	Second core thickness	Third core thickness	Distance of projection	Anchoring system
L. 0042	2	-	Greek double core	Cord	Cord	-	Medium	Medium	-	25mm - (12,3%)	EAS 2
L. 0046	2	-	Greek double core	Cord	Cord	-	Medium	Thick	-	60mm - (15,8%)	EAS 2
L. 0258	2	-	Greek double core	Cord	Cord	-	Medium	Medium	-	45mm - (15,5%)	EAS 2
L. 0392	2	Feather stitch	Greek double core	Cord	Cord	-	Thin	Medium	-	25 mm - (21,7%)	EAS 2
L. 0436	N.k (missing)	Feather stitch	N.k. (missing)	N.k.	N.k.	N.k.	N.k.	N.k.	-	70 mm - (25%)	EAS 2
L. 0528	2	-	Single warps	Cord	Cord	-	Thick	Thick	-	45 mm - (23,5%)	EAS 2
L. 0581	N.k (missing)	-	N.k. (missing)	N.k.	N.k.	N.k.	N.k.	N.k.	-	N.k.	EAS 2
L. 0593	2	-	Greek double core	Cord	Cord	-	Medium	Medium	-	25 mm - (12,3%)	EAS 2
L. 0697	1	-	Greek single core	Cord	-	-	Medium	-	-	N.k.	N.k.
L. 0754	2	-	Unclear on single warps around 1 <sup>st</sup> core	Cord	Cord	-	Medium	Medium	-	14 mm - (12%)	EAS 3
L. 0783	1	-	Embroidered front bead (2 colours)	Cord	-	-	Medium	-	-	A few mm.	EAS 3
L. 0810	2	-	Greek double core	Leather	Leather	-	Medium	Medium	-	N.k.	N.k.
L. 0837	3	-	Wound plain on 1 <sup>st</sup> core	Cord	Cord	Cord	Medium	Medium	Thin	50 mm - (25,7%)	EAS 2
L. 0907	2	-	Greek double core	Cord	Cord	-	Medium	Medium	-	27 mm - (38,5%)	EAS 2
L. 1585	2	-	Greek double core	Cord	Cord	-	Medium	Medium	-	N.k.	N.k.
L. 1588	3	-	Wound plain on 1 <sup>st</sup> core	Cord	Cord	Thread	Medium	Medium	Thin	N.k.	N.k.
L. 1589	5	-	Single warps	Cord	Cord	-	Thick	Thick	-	55 mm - (21,7%)	EAS 2

Table 137. Endband cores information.

Catalogue Number	E. P. S. type	E. P. S. thread	E. P. S. threads colour	E. P. S. thread thickness	E. P. S. thread ply	E. P. S. thread twist	Number of tie-downs	Tie-downs position	Thread anchorage
L. 0042	Greek double core	Hemp (SaS)	Natural	Medium	2Z	Loose	As many as gatherings	Centre-fold	Uses change-over station
L. 0046	Greek double core	Hemp (SaS)	Natural	Medium	2Z	Loose	As many as gatherings	Centre-fold	Uses other passing hole outside
L. 0258	Greek double core	Linen (SaS)	Natural	Medium	2Z	Medium	As many as gatherings	Centre-fold	Uses change-over station
L. 0392	Greek double core	Hemp	Natural	Thick	S	Medium	Nk	Centre-fold	Uses change-over station
L. 0436	N.k. (missing)	Linen	Natural	Thin	S	Tight	As many as gatherings	Centre-fold	Uses change-over station
L. 0528	Single warps	Hemp (SaS)	Natural	Medium	2S	Loose	N.k.	Centre-fold	Uses other passing hole outside
L. 0581	N.k. (missing)	N.k.	N.k.	N.k.	N.k.	N.k.	N.k.	N.k.	N.k.
L. 0593	Greek double core	Linen	Natural	Thin	2S	Tight	N.k.	Centre-fold	Uses other passing hole outside
L. 0697	Greek single core	Hemp (SaS)	Natural	Medium	2S	Medium	N.k.	Centre-fold	Uses other passing hole outside
L. 0754	Unclear on single warps around 1 <sup>st</sup> core	Linen	Natural	Medium	4S	Tight	As many as gatherings	Centre-fold	Uses other passing hole outside
L. 0783	Embroidered front bead (2 colours)	Silk	Red, White	Medium	?Z	Medium	N.k.	Centre-fold	Uses other passing hole outside
L. 0810	Greek double core	Hemp	Natural	Thick	2S	Loose	As many as gatherings	Centre-fold	Uses other passing hole outside
L. 0837	Wound plain on 1 <sup>st</sup> core	Hemp	Natural	Thin	?S	Loose	N.k.	Centre-fold	Uses change-over station
L. 0907	Greek double core	Hemp	Natural	Thick	?Z	Medium	As many as gatherings	Centre-fold	Uses change-over station
L. 1585	Greek double core	Cotton ?(SaS)	Natural	Thin	2 2s Z	Tight	N.k.	Centre-fold	Uses change-over station
L. 1588	Wound plain on 1 <sup>st</sup> core	Linen	Natural	Thin	2S	Tight	As many as gatherings	Centre-fold	Uses change-over station
L. 1589	Single warps	Hemp (SaS)	Natural	Medium	2S	Loose	N.k.	Centre-fold	Uses change-over station

Table 138. Endband primary sewing information.

Catalogue Number	E. S. S. / W. type	E. S. S. / W. colours	E. S. S. / W. thread	E. S. S. / W. thread thickness	E. S. S. / W. thread ply	E. S. S. / W. thread twist
L. 0042	Cretan on single warps	Red, yellow, blue / Red	Silk / Silk	Thin / Thin	2S / 2S	Medium / medium
L. 0046	None	-	-	-	-	-
L. 0258	None	-	-	-	-	-
L. 0392	None	-	-	-	-	-
L. 0436	N.k.	N.k.	N.k.	N.k.	N.k.	N.k.
L. 0528	Armenian two cores	Green, red, yellow, silver	Silk, silver around silk	Thin	2S	Medium
L. 0581	N.k.	N.k.	N.k.	N.k.	N.k.	N.k.
L. 0593	None	-	-	-	-	-
L. 0697	None	-	-	-	-	-
L. 0754	N.k.	N.k.	N.k.	N.k.	N.k.	N.k.
L. 0783	None	-	-	-	-	-
L. 0810	None	-	-	-	-	-
L. 0837	3-core Chevron & crowning core	Blue(?), Red, Yellow	Silk	Thin	7S	Medium
L. 0907	None	-	-	-	-	-
L. 1585	None	-	-	-	-	-
L. 1588	3-core Chevron & Crowning core	Red, yellow	Silk	Thin	3S	Tight
L. 1589	Armenian five cores	Green, red, yellow, silver	Silk, silver around silk	Thin	2S	Medium

Table 139. Endband secondary sewing / weaving information.

Catalogue Number	Marker	Primary Marker	P. M. material & colour	P. M. way of attachment	Secondary Marker	S. M. material & colour	S. M. way of attachment
I. 0042	None	-	-	-	-	-	-
I. 0046	Simple	Leaf tab markers	Red leather	FpbsL	-	-	-
I. 0258	Compound	Simple open loop	Natural colour linen	LtH(f)	Single colour thread string	Natural colour linen	N.k. (detached)
I. 0392	Compound	3 simple open loops	Natural colour hemp	LtH(a)	Unclear (only vestiges)	Red & yellow silk	KiE?
I. 0436	Simple	Leaf tab markers	Brown leather	FpbsL	-	-	-
I. 0528	Simple	Leaf tab markers	Brown-black leather	FpbsL	-	-	-
I. 0581	None?	-	-	-	-	-	-
I. 0593	Simple	Leaf tab markers	Brown leather	FpbsL	-	-	-
I. 0697	Compound	Simple open loop	Natural colour hemp	LtH(d)	Unclear (only vestiges)	Red & white silk	N.k.
I. 0754	None	-	-	-	-	-	-
I. 0783	None	-	-	-	-	-	-
I. 0810	None	-	-	-	-	-	-
I. 0837	Simple / simple / simple	Leaf tab markers / Board tab markers / Endband string marker	Red leather / SaC. leather / natural colour linen 2 2z	TpbsL / LtSp / LtH(a)	-	-	-
I. 0907	None	-	-	-	-	-	-
I. 1585	Simple?	Endband string marker	Off-white cotton cord	LtH(b)	-	-	-
I. 1588	None	-	-	-	-	-	-
I. 1589	Compound	2 simple open loops?	Yellow silk	LtH(f)	Single colour thread string	Natural colour hemp	KiM

Table 140. Markers information.



Catalogue Number	Cover material type	Cover colour	Turn-ins type	Turn-ins width	Corners mitre
I. 0042	Goat leather	Brown	T-ins 3	Varies	Varies
I. 0046	Goat leather	Dark brown	T-ins 1, T-ins 5	Varies	Co 4
I. 0258	Sheep? leather	Brown	T-ins 2	Medium	Varies
I. 0392	Leather	Brown	T-ins 2	Varies	Co 8, Co 6
I. 0436	Goat leather	Dark brown	T-ins 3	Wide	Co 6
I. 0528	Goat leather	Red-brown	T-ins 3	Wide	Co 6
I. 0581	N.k.	-	-	-	-
I. 0593	Goat leather	Black	T-ins 3	Wide	Co 6
I. 0697	Leather	Brown	N.k. (boards missing)	N.k. (boards missing)	N.k. (boards missing)
I. 0754	Goat leather	Black	T-ins 3	Wide	Co 6
I. 0783	Goat leather	Brown	T-ins 3	Varies	Co 6
I. 0810	N.k. (missing)	N.k.	N.k. (boards missing)	N.k. (boards missing)	N.k. (boards missing)
I. 0837	Leather	Black	T-ins 2	Wide	Co 1
I. 0907	Goat leather	Black	T-ins 2	Wide	Co 1, Co 7
I. 1585	Goat leather	Dark brown	N.k. (boards missing)	N.k. (boards missing)	N.k. (boards missing)
I. 1588	Leather	Dark brown	N.k. (boards missing)	N.k. (boards missing)	N.k. (boards missing)
I. 1589	Goat leather	Brown	T-ins 3	Varies	Co 6, Co 5

Table 141. Cover information.

Catalogue Number	Left / Right difference	Decoration patterns	Spine decoration pattern	Board edges decoration pattern	Decoration tools	Number of tools
I. 0042	No	Dec6ab	Yes, other	BED 10	MuF/a3, MuF/c3, MuF/d19, MuF/d39, MuA/b2, MuG/a6, MuG/c4, C8	8
I. 0046	No	Dec7	No	None	MuF/a3, MuA/b2, MuA/d1, MuG/a6, MuG/c6, C8	6
I. 0258	No	Dec7aV	N.k. (badly preserved)	None	MuF/a3, MuF/c3, MuF/c47, MuF/d19, MuF/d39, MuA/c1, MuA/d1, MuG/a7, MuG/c6, C8	11
I. 0392	No	Dec6a	SD4/B	None	MuF/a3, MuF/e12, MuA/b2, MuA/c1, MuA/d1, MuG/a6, MuG/c4, C8	8
I. 0436	No	Dec7abV	No	BED 10	MuF/a3, MuF/c2, MuF/d17, MuF/d39, MuA/b2, MuA/c1, MuA/d1, MuG/a6, C8	9
I. 0528	No	Dec6a	SD3/B	None	MuF/a3, MuF/d8, MuF/e12, MuA/a4, MuA/c1, MuG/a6, C8	7
I. 0581	N.k.	N.k. (volume rebound)	N.k.	N.k.	N.k.	N.k.
I. 0593	Yes	Dec4(L), Dec12a+Dec4 (R)	Yes unclear	None	MuF/a3, MuF/c3, MuF/d8, MuF/d14, MuF/e12, MuA/a4, MuA/b2, MuA/c1, MuA/d1, MuG/a6, C8	11
I. 0697	N.k.	N.k. (boards missing)	No	N.k.	N.k.	0
I. 0754	No	Dec6	Yes unclear	None	MuA/a4, MuF/c3, MuA/b2, MuA/c1, MuG/a6, C8	6
I. 0783	No	Dec6	No	None	MuF/a3, MuF/c3, MuA/a4, MuA/b2, MuA/d1, MuG/a6, C8	7
I. 0810	N.k.	N.k. (boards missing)	No	N.k.	N.k.	0
I. 0837	Yes	Dec13abc(L), Dec6a (R)	No	None	MuF/a3, MuF/c3, MuF/d17, MuF/d19, MuA/b2, MuA/c1, MuA/d1, MuG/a6, MuG/c4, MuG/c6, C8	11
I. 0907	No	Dec5?	SD4/B	None	MuF/a3, MuF/c3, MuA/b2, MuA/c1, MuG/a6, C8	6
I. 1585	N.k.	N.k. (boards missing)	SD4/B	None	MuA/b2, C8	2?
I. 1588	N.k.	N.k. (boards missing)	No	N.k.	N.k.	0
I. 1589	No	Dec10abV	SD4/B	None	MuF/a3, MuF/c3, MuF/d8, MuF/e12, MuA/b2, MuA/c1, MuG/a6, C8	8

Table 142. Decoration information.

Tool	Volumes where it is used	Number of volumes where it is used
MuF/a3	I. 42, I. 46, I. 258, I. 392, I. 436, I. 528, I. 593, I. 783, I. 837, I. 907, I. 1589	11
MuF/c2	I. 436	1
MuF/c3	I. 42, I. 258, I. 593, I. 754, I. 783, I. 837, I. 907, I. 1589	8
MuF/c47	I. 258	1
MuF/d8	I. 528, I. 593, I. 1589	3
MuF/d14	I. 593	1
MuF/d17	I. 436, I. 837	2
MuF/d19	I. 42, I. 258, I. 837	3
MuF/d39	I. 42, I. 258, I. 436	3
MuF/e12	I. 258, I. 392, I. 528, I. 593, I. 1589	5
MuA/a4	I. 528, I. 593, I. 783	3
MuA/b2	I. 42, I. 46, I. 258, I. 392, I. 436, I. 593, I. 754, I. 783, I. 837, I. 907, I. 1589	11
MuA/b16	I. 46, I. 258, I. 392, I. 436, I. 593, I. 783, I. 837	7
MuA/c1	I. 258, I. 392, I. 436, I. 528, I. 593, I. 754, I. 837, I. 907, I. 1589	9
MuG/a6	I. 42, I. 46, I. 392, I. 436, I. 528, I. 593, I. 754, I. 783, I. 837, I. 907, I. 1589	11
MuG/a7	I. 46	1
MuG/c4	I. 42, I. 392, I. 837	3
MuG/c6	I. 46, I. 258, I. 837	3
C8	All except I. 581, I. 697, I. 810, I. 1588 (volumes with missing boards)	13

**Table 143. Tools information.**

Catalogue Number	Metal furniture type	Number of Furniture	Attachment method	Metal	Text-block format	Binding thickness
I. 0042	Bosses	9 (-5) L, 9 (-2) R	Nailed, ends flattened above the pds	Lead	8vo	70
I. 0046	Bosses	9(-2) L, 9 (-1) R	Nailed, ends flattened above t-ins and some above circular leather cuttings	Copper alloy	Folio	112
I. 0258	Bosses	5 (-5) L, 5 (-5) R	Nailed, ends underneath the pds	Copper alloy	Folio	105
I. 0392	Bosses	9 (-9) L, 9 (-9) R	Nailed, ends underneath the pds	Copper alloy	8vo	127
I. 0436	Bosses?	9 (-9) L, 9 (-9) R	Nailed, ends flattened above the t-ins.	Lead	4to	115
I. 0528	Metal cross	1 (-1) L	Nailed with 4 nails, ends not visible	N.k.	8vo	114
I. 0581	N.k. (volume rebound)	-	-	-	Folio	90
I. 0593	Bosses	5 (-5) L, 5 (-5) R	Nailed, ends flattened above the t-ins.	N.k.	4to	90
I. 0697	N.k. (boards missing)	-	-	-	16mo	(60)
I. 0754	None	-	-	-	16mo	35
I. 0783	None	-	-	-	8vo	30
I. 0810	N.k. (boards missing)	-	-	-	8vo	(43)
I. 0837	None	-	-	-	8vo	90
I. 0907	None	-	-	-	16mo	120
I. 1585	N.k. (boards missing)	-	-	-	8vo	40
I. 1588	N.k. (boards missing)	-	-	-	8vo	(91)
I. 1589	Metal cross	1 (-1) L	Nailed with 4 nails, ends not visible.	N.k.	8vo	57

**Table 144. Metal fittings information.**

Catalogue Number	Number of FS	Fastenings type	Fastenings material	Strap anchorage type	Fastenings & T-ins arrangement	Ends form	Arrangements of anchorage holes	Metal components
I. 0042	0-2-0 ←	Two edged leather interlaced straps / N.k.	SaC, metal (?) ring & antler pin	TBTP	F & T 1	UfaP	AH 2	Rings (M)
I. 0046	1-2-1 ←	Modern imitation of three edged leather interlaced straps / standard type.	Leather? metal	TBT	F & T 1, F & T 6	N.k.	AH 4	Rings (not original) & cast metal compound pins
I. 0258	0-2-0 ←	Three edged leather interlaced straps / N.k.	SaC and metal	TB	F & T 5	Tfi	AH 4	Rings (M) & cast metal compound pins
I. 0392	1-2-1 ←	Three edged leather interlaced straps / N.k.	SaC and metal	TBT	F & T 1	TuP	AH 4	Rings (M) & pins ? (M)
I. 0436	1-2-1 ←	Three edged leather interlaced straps / N.k.	N.k.	TBT	F & T 1?	N.k.	AH 4	Rings (M) & pins ? (M)
I. 0528	0-2-0 ←	Three edged leather interlaced straps / N.k.	SaC and metal	TBT	F & T 1	Ufi	AH 4	Rings (?) & cast and filed metal compound pins
I. 0581	N.k. (rebound)	N.k.	-	-	-	-	-	-
I. 0593	0-2-0 ←	Three edged leather interlaced straps / N.k.	N.k.	TBTP	F & T 1	N.k.	AH 4	Rings (M) & pins ? (M)
I. 0697	N.k. (Bds M)	N.k.	-	-	-	-	-	-
I. 0754	0-2-0(?) →←	Leather (?) ties	N.k.	TBT	F & T 1	N.k.	AH 5	None ?
I. 0783	0-1-0 →	Long leather (?) tie	N.k.	TCT of flap	F & T 1	N.k.	AH 6	None ?
I. 0810	N.k. (Bds M)	N.k.	-	-	-	-	-	-
I. 0837	0-2-0 ←	Three edged leather interlaced straps / N.k.	Different, metal ?	TB	F & T 2	Ufi	AH 4	Rings (M) & cast metal compound pins
I. 0907	0-2-0 ←	Three edged leather interlaced straps / N.k.	Same, metal ?	TBT	F & T 1	Ufi	AH 4	Rings (M) & cast metal compound pins
I. 1585	N.k. (Bds M)	-	-	-	-	-	-	-
I. 1588	N.k. (Bds M)	-	-	-	-	-	-	-
I. 1589	0-2-0 ←	Three edged leather interlaced straps / standard type	Same, metal	TBT	F & T 1	Ufi	AH 4	Rings & cast metal compound pins

Table 145. Fastenings information.

## THE THEOCLITOS BINDINGS

Catalogue Number	Text chronology	Title	Scribe	Text-block format	Leaves number	Notes	1st binding?
I. 0785	1488	Thikaras (L)	Nk	8o (215 x 155)	247 WPP	f. 246v. «αυτή η βιβλίος του θηκαρά υπάρχει του παπά δαμασκινού του κουζού του εκ θεσσαλονίκης εκτήσατο δε αυτήν δωρεάν από πνός μοναχού αθηνέου» f. 245 r. «... έτους στθ Κο στ' (6996/7AM = 1488 AD) ηδικτιόνος στ' κατά μήνα [...]» f. 177 v. : «κτίμα γαβριήλ και θεοκλήτου πόνος»	No, at least 2nd
I. 0838	17 th. c. (1 <sup>st</sup> quarter)	Various Himnological (L)	Theoclitos <i>hieromonk</i>	8o (206 x 150)	211 WP		Yes
I. 1215	17 th. c. (1 <sup>st</sup> quarter)	Silitourgia (L)	Nk	16mo (152 x 102)	100 WPP	f. 1r. A note with the date 1625, concerning a pilgrimage of the <i>proigoumenos</i> . There are various other notes.	Yes
I. 1498	1522	Liturgy of St. Basil (L)	<i>Hosios</i> Theophilos	8o (210 x 150)	65 WP	f. 62 v. «... Θεού το δώρον και Θεοφίλου πόνος έτους ζαα' (7031 AM = 1522 AD) μηνί σεπτεμβρίω...»	No, at least 2nd
I. 1500	1514/15	Liturgy of St. John Chrysostom (L)	<i>Hosios</i> Theophilos	8o (223 x 168)	32 WP	f. 31v. « έται ζκα' (7023 AM = 1514/5 AD) ηδικτιόνος γ' »	No, at least 2nd
I. 1503	16 th. c. (end)	Liturgy of St. John Chrysostom (L)	Laurentios	8o (215 x 155)	32 WPP	f. 31v. « θεού το δώρον και λαυρεντίου πόνος»	Yes
I. 1533	1622	Liturgy (L)	Mathaios Mireon	8vo (210 x 150)	98 WPP	f. 94 v. «Αυτή η λειτουργία εγράφη δια χειρός ματθίου μαρτωλού μητροπολίτου μωρέων και αφιερώθη εν τη σεβασμία και βασιλική μονή των ιβήρων και ο αποξενώσας τώτην εξ αυτής ούκ αιτιώρητος έσεται εν έτει ζραα' (7131 AM = 1622 AD)) μηνί δεκεμβρίω κατ' ηδικτιόνος στ'»	Yes
I. 1552	1606/7	Liturgy of Proigiasmenon (L)	Theoclitos <i>hieromonk (a)</i>	8o (210 x 150)	26 WPP	f. 23 r. «Θεού το δώρον και Θεοκλήτου πόνος ζριε' (7114/5 AM = 1606/7 AD)»	Yes

Table 146. Text-block information.

Catalogue Number	Original binding?	Spine-fold repair type and material	Text-block repair type and material
I. 0785	No, at least 2nd	Western paper strips pasted locally in some bifolia	Western paper strips pasted occasionally
I. 0838	Yes		
I. 1215	Yes		
I. 1498	No, at least 2nd	Ms waste paper strips pasted locally in the spine-fold of a few bifolia.	
I. 1500	No, at least 2nd	Western paper strips pasted all along the spine-folds of most text-block bifolia.	Western paper strips pasted occasionally
I. 1503	Yes		
I. 1533	Yes		
I. 1552	Yes		

Table 147. Repair information.

Catalogue Number	Original binding?	Date of binding	Left endleaf arrangement	Right endleaf arrangement
I. 0785	No, at least 2nd	17 <sup>th</sup> c, 1 <sup>st</sup> quarter	[2] 2	2 [2]
I. 0838	Yes	17 <sup>th</sup> c, 1 <sup>st</sup> quarter	[2] 2	\ 3 [1,1]
I. 1215	Yes	17 <sup>th</sup> c, 1 <sup>st</sup> quarter	[2] 6	6 [2]
I. 1498	No, at least 2nd	17 <sup>th</sup> c, 1 <sup>st</sup> quarter	[2] 2	\ [1]
I. 1500	No, at least 2nd	17 <sup>th</sup> c, 1 <sup>st</sup> quarter	[2] 2	2 [2]
I. 1503	Yes	17 <sup>th</sup> c, 1 <sup>st</sup> quarter	[2] 2	[2]
I. 1533	Yes	1622	[3] 1	1 [3]
I. 1552	Yes	1606-7	[2] 2	2 [2]

Table 148. Endleaves information.

Catalogue Number	Number of sewing stations	Distance between stations / Pattern of sewing stations	Accommodation nicks	Sewing thread	Sewing thread thickness	Sewing thread twist	Sewing thread ply	Format of text-block	Thickness of text-block
I. 0785	4	28-50-50-48-40 /B1?	V-shaped cuts	Hemp	Medium	Medium	2S	8vo	46
I. 0838	4	22-53-55-55-17 /B1	V-shaped cuts	Hemp	Medium	Tight	2S	8vo	45
I. 1215	3	22-48-47-33 /B1	V-shaped cuts	Linen	Thin	Loose	2S	16mo	17
I. 1498	4	23-52-53-52-21 /B1	V-shaped cuts	Linen	Medium	Tight	2Z	8vo	14
I. 1500	4	30-50-55-54-35 /B1	V-shaped cuts	Linen	Medium	Tight	2Z	8vo	5
I. 1503	3	17-90-87-18 /B1	Needle holes	Silk (pink)	Thin	Loose	2Z	8vo	7
I. 1533	4	25-56-56-41-(35?) /B1?	Small V-shaped cuts	Hemp	Medium	Loose	4S	8vo	18
I. 1552	4	15-60-60-60-15 /B1	V-shaped cuts	Silk (blue)	Thin	Tight	2Z	8vo	6

Table 149. Sewing information.

Catalogue Number	Attachment system	Material	Dimensions	Type of spine edge treatment	Spine joints	Format of text-block	Thickness of boards	Thickness of text-block
I. 0785	II Uns /B2	Pasteboard	Flush	SET 1	None	8vo	3	46
I. 0838	II Uns /B2	Pasteboard	Flush	SET 1	None	8vo	3	45
I. 1215	II Uns /B2	Pasteboard	Flush	SET 1	None	16mo	2	17
I. 1498	II Uns /B2	Pasteboard	Flush	SET 1	None	8vo	3	14
I. 1500	II Uns /B2	Pasteboard	Flush	SET 1	None	8vo	3	5
I. 1503	II Uns /B2 (L), II Uns /B5 (R)	Pasteboard	Flush	SET 1	None	8vo	3	7
I. 1533	II Uns /B4	Pasteboard	Flush	SET 1	None	8vo	3	18
I. 1552	II Uns / A2 or II Uns/ B 2	Pasteboard	Flush	SET 1	None	8vo	3	6

**Table 150. Boards information.**

Catalogue Number	Spine lining	Material	Thickness	Board covered	Side of boards covered	Spine shape	Thickness of text-block
I. 0785	Yes all through	Canvas	Thin	N.k.	Inside	Flat	46
I. 0838	Yes all through	Canvas	Medium	N.k.	Inside	Flat	45
I. 1215	Yes all through	Canvas	Medium	30%?	Inside	Flat	17
I. 1498	Yes all through	Canvas	Thin	N.k.	Inside	Flat	14
I. 1500	Yes all through	Plain textile	Thin	N.k.	Inside	Flat	5
I. 1503	Yes all through	Canvas	Medium	N.k.	Inside	Flat	7
I. 1533	Yes all through	Canvas	Thin	50%?	Inside	Flat	18
I. 1552	Yes all through	Canvas	Thin	N.k.	N.k.	Flat	6

**Table 151. Spine lining information.**

Catalogue Number	Number of cores	Endband primary weaving (E. P. W.) type	Core material	Core size	Distance of projection	Anchoring system	Format of text-block
I. 0785	1	Islamic	Leather	Medium	A few mm.	EAS 6?	8vo
I. 0838	1	Islamic	Leather	Thin	N.k.	N.k.	8vo
I. 1215	1	Islamic	Leather	Thin	A few mm.	EAS 6	16mo
I. 1498	1	Islamic	Leather	Medium	A few mm	EAS 6	8vo
I. 1500	1	Islamic	Leather	Medium	N.k.	N.k.	8vo
I. 1503	1	Islamic	Leather	Medium	A few mm	EAS 6	8vo
I. 1533	1	Islamic	Leather	Medium	A few mm	EAS 6	8vo
I. 1552	1	Islamic	Leather	Medium	A few mm.	EAS 6?	8vo

**Table 152. Endband cores in formation.**

Catalogue Number	S. E. T.	Endband preliminary sewing	Endband preliminary sewing thread	Endband preliminary sewing thread thickness	Endband preliminary sewing thread twist	Endband preliminary sewing thread ply	Number of tie-downs	Tie-downs position	Tread anchorage
I. 0785	1	Double warps	Natural hemp (SaS)	Thin	Medium	2S	As many as gatherings ?	Centre-fold	Uses change-over station
I. 0838	1	Double warps	Bleached linen	Thin	Tight	2S	As many as gatherings	Centre-fold	Uses change-over station
I. 1215	1	Double warps	Natural linen	Thin	Medium	2S	As many as gatherings	Centre-fold	Uses change-over station
I. 1498	1	Single warps	Natural linen	Thin	Medium	2S	Nk	Centre-fold	Uses change-over station
I. 1500	1	Double warps	Natural linen	Thin	Medium	2S	As many as gatherings	Centre-fold	Uses other hole outside
I. 1503	1	Single warps	Bleached linen	Thin	Tight	2S	As many as gatherings	Centre-fold	Uses change-over station
I. 1533	1	Single warps	Natural linen	Thin	Medium	2S	As many as gatherings	Centre-fold	Uses change-over station
I. 1552	1	Single warps	Blue Silk (SaS)	Thin	Tight	2Z	As many as gatherings	Centre-fold	Uses change-over station

**Table 153. Endband preliminary sewing type.**

Catalogue Number	E. P. W. type	E. P. W. tread	E. P. W. thread colour/s	E. P. W. thread twist	E. P. W. thread thickness	E. P. W. thread ply
I. 0785	Islamic	Silk	Red, white	Medium	Medium	2S
I. 0838	Islamic	Silk	Red, white(?)	Nk	Medium	2S
I. 1215	Islamic	Silk	Red, yellow	Medium	Medium	2S
I. 1498	Islamic	Silk, silver thread	Red, silver around yellow silk	Medium	Medium	?S, S
I. 1500	Islamic	Silk, silver thread	Red, silver around yellow silk	Medium	Medium	?S, S
I. 1503	Islamic	Silk, silver thread	Green, silver around yellow silk	Nk	Medium	?S, S
I. 1533	Islamic	Silk, silver thread	Red, silver around yellow silk	Tight	Medium	2S, S
I. 1552	Islamic	Silk, silver thread	Green, silver around yellow silk	Nk	Medium	?S, S

Table 154. Secondary endband information.

Catalogue Number	Marker	Primary marker	Primary marker material & colour	Primary marker way of attachment	Secondary marker	Secondary marker material & colour	Secondary marker way of attachment
I. 0785	Compound	3 simple closed loops	Red & white silk (SaE) plied together.	LtH(f)	3 single colour strings	2 blue, 1 yellow silk strings	Unclear
I. 0838	No	-	-	-	-	-	-
I. 1215	N.k. (missing?)	-	-	-	-	-	-
I. 1498	Compound	1 simple closed loop	Red silk & silver (SaE) plied together	C?	Missing	Missing	KIM?, KIE?
I. 1500	Compound	1 simple closed loop	Red Silk (SaE).	LtH(f)	1 single colour string	Blue silk	KIM
I. 1503	Compound	1 simple open loop	Green silk (SaE).	LtH(f)	2 two-colour strings	Green & blue silk (SaE)	L
I. 1533	Vestiges	N.k.	Red & blue silk (SaE).	LtH(f)	Missing	Missing	Missing
I. 1552	Compound	1 simple open loop	Green silk (SaE).	LtH(f)	1 two-colour string	Green (SaE) & blue silk	L

Table 155. Marker information.

Catalogue Number	Cover material	Cover colour	Turn-ins type	Turn-ins width	Corners mitre
I. 0785	Goat leather	Brown	T-ins 1, T-ins 2	Varies	N.k.
I. 0838	Goat leather	Brown yellow	T-ins 1, T-ins 2	Medium	Co 1, Co 7
I. 1215	Goat leather	Black	T-ins 1, T-ins 3	Varies	Co 1, Co 4
I. 1498	Goat leather	Black-Brown	T-ins 3	Varies	Co 1
I. 1500	Goat leather	Brown light	T-ins 2?	Varies	Co 1
I. 1503	Goat leather	Red-brown	T-ins 3	Varies	N.k.
I. 1533	Goat leather	Brown yellow	T-ins 3	Varies	Co 1
I. 1552	Goat leather	Brown	T-ins 1, T-ins 3	Varies	Co 4

Table 156. Cover information.

Catalogue Number	Left / Right difference?	Decoration pattern	Spine decoration pattern	Tools	Number of tools
I. 0785	No	Dec 2	None	MuF/a3, MuF/c12, MuG/a5, fillets	4
I. 0838	No	Dec 2	SD 5?/B	MuF/a3, MuF/c12, MuG/a5, fillets	4
I. 1215	No	Dec 2	None	MuF/c12, MuG/a5, fillets	3
I. 1498	No	Dec 3	None	MuF/a2, MuF/c12, MuG/a5, MuV19, fillets	6
I. 1500	Yes	Dec 1a(L), Dec 2 (R)	None	MuF/a2, MuF/c12, MuG/a5, fillets	4
I. 1503	Yes	Dec 2 (L), Dec 4 (R)	None	MuF/c12, MuA/c5, MuG/a5, fillets	4
I. 1533	No	Dec 3	None	MuF/c12, MuG/a5, CeF32, fillets	4
I. 1552	Yes	Dec 2 (R), Dec 4 (L)	None	MuF/c12, MuG/a5, fillets	3

Table 157. Decoration information.

Tool	Volumes where it is used	Number of volumes where it is used
MuF/a2	I. 1492, I. 1500	2
MuF/a3	I. 785, I. 838, I. 1498, I. 1500	4
MuF/c12	All volumes	8
MuF/e12	I. 1492	1
MuA/c5	I. 1503	1
MuG/a5	All volumes	8
MuV19	I. 1498	1
CeF32	I. 1533	1
Fillets	All volumes	8

Table 158. Tools information.

Catalogue Number	Number of Fastenings	Fastenings type	Fastenings material	Anchorage type	Fastenings and turn-ins arrangement	Ends form	Arrangement of anchorage holes.
I. 0785	0-2-0→←	Leather straps	Leather (SaC)	TBTP	F & T I	TpaP	AH5
I. 0838	0-2-0→←	Textile ribbon	Silk	TBTP	F & T I	TpaP	AH5
I. 1215	0	None	-	-	-	-	-
I. 1498	0	None	-	-	-	-	-
I. 1500	0	None	-	-	-	-	-
I. 1503	0	None	-	-	-	-	-
I. 1533	0	None	-	-	-	-	-
I. 1552	0	None	-	-	-	-	-

Table 159. Fastenings information.



## THE PAPANEOPHITOS BINDINGS

Catalogue Number	Text Chronology	Title	Scribe/s	Format of text-block	Number of leaves	Notes	Original binding?
I. 0393	1642	Thikaras (L)	Simeon <i>hieromonk</i> & Papasophronios from Stavronikita	8vo (210 x 153)	323 WPP	f. 385v. «Το παρόν βιβλίον ωνομαζόμενον θεικαράς επάρχει καμίου του ευτελούς σμμεού του μοναχού και χατζή ελάχειστου και ει πατρίδα μου, υπάρχει η μακεδωνοία απο επαρχοίαν φιλοίτου και δράμας απο χορίον, ωνόματι ραδωλοΐβου και έγνα καλόγερος ω ανάξιος εις την μονί του προδρόμου ωπού είναι εις τα σέρας και το εφρότησα ώταν εκαθόμουν εις το κελού το σταβρονοικτιανώ και έγραψα και εγώ ολίγο και το επίλιπον το έγραψεν ω παπασοφρόνοιος απο την σταβρονοικία οπού ήταν απο την κό και εις τους ύμνους του ώρθρου έγραψεν ο παπαντόνεις ολίγο, εις την αγιανα ω ξεροποταμινός και το εστάχουσε ω παπανέωφτος εις τες καραίς, ω αργυροκαστρινός. Και ετελιόθι με χάρις χριστού κατά το έτους 7150(AM = 1642 AD) ζρν' τνδ' ι' εν μνί ειούνω εις τας κη' ημέρα τετράδι ώρα γ' κ(αι) τω χριστώ δόξα.»	No, at least 2nd
I. 0473	1642	Theotokarion (L)	Simeon <i>hieromonk</i> & Papasophronios from Stavronikita	8vo (211x150)	160 WPP	f. 160v. «Το παρόν βιβλίον ωνομαζόμενον θεωτοκάρι επάρχει εμού του ευτελούς σμμεού μοναχού και χατζή ελάχειστου και ει πατρίδα μου επάρχει η μακεδωνοία απο επαρχοίαν φιλοίτου και δράμας απο χορίον ωνόματι ραδωλοΐβου και έγνα καλόγερος ω ανάξιος εις την μονί του προδρόμου ώπου είναι εις τα σέρας και το εφρότησα ώταν εκαθόμουν εις το κελού το σταυρονοικτιανώ και έγραψα και εγώ ολίγο και το επίλιπον το έγραψεν ω παπασοφρόνοιος απο την σταβρονοικία ώπου ήταν απο την κό και το εστάχουσε ω παπανέωφτος απο τες καραίς ώπου ήταν απο το αργυρόκαστρο και ετελιόθι με χάρις θεού κατά το έτους 7150 (AM = 1642 AD) ζρν' τνδ' ι' εν μνί ειούνω εις τας κη' ημέρα τετράδι ώρα γ' και τώ θεώ δόξα.»	Yes
I. 0625	1654	St. John Chrysostom speeches (T)	Antonios Ksiropotaminos	8vo (210 x 140)	393 WPP	f. 385 r. «Το παρόν βιβλίον έγραφη δια χειρός αντωνίου ιερομονάχου δια εξέδου και προτροπής διονυσίου ιερομονάχου του εκ της ιερής και βασιλικής μονής των ιβήρων αντιγράφει δε από παλαιών ντεβράνων βιβλίον του μοναστηρίου επί έτους ζρξβ'(7162 AM = 1654 AD)- ετελειώθει εν μνηή αύγουστου εις τας καρέας του αγίου όρους . Και όστις αναγγνώσκει εύχεσθαι υπερ ημών»	Yes
I. 0835	1426	Horologion (L)	N.k.	8vo (226 x 140)	211 WP	f. 208 r. «Ετελειώθη η παρούσα ασκητική βιβλος αύτη εν μνηή Δεκεμβρίω ιστ' του σιςαμλε'(6935 AM = 1426 AD) ) τνδ' ε'».	No, at least 2nd
I. 1168	17th c. 1 <sup>st</sup> half	Sticherarion (L)	N.k.	16mo (152 x 98)	315 WPP		Yes
I. 1221	17th c. 1 <sup>st</sup> half	Sticherarion (L)	N.k.	16mo (152 x 110)	471 WPP		Yes

Table 160. Text-block information.

Catalogue Number	Date of Binding	Original binding?	Type of binding	Place of Binding	Binder	Note
I. 0393	19 th c. end of	No, at least 2nd	Western-style binding	Karies/Athos (originally) & Iviron (present)	Papaneophitos (originally)	f. 385v. «... και το εστάχισε ω παπανεώφητος εις τες καραίς, ω αργυροκαστρινός. Και ετελιόθη με χάρις χριστού κατά το έτους 7150 ζρν' ινδ' ι' εν μινί ειούνηω εις τας κη' ημέρα τετράδι ώρα γ' κ(αι) τω χριστώ δόξα.»
I. 0473	1642	Yes	Greek-style binding	Karies/ Athos	Papaneophitos	f. 160v. «...και το εστάχισε ω παπανεώφητος απο τες καραίς ώπον ειταν απο το αργυρόκαστρο και ετελιόθη με χάρις θεού κατά το έτους 7150 ζρν' ινδ. ι' εν μινί ειούνηω εις τας κη' ημέρα τετράδι ώρα γ' και τώ θεώ δόξα.»
I. 0625	1654	Yes	Greek-Islamic binding	Karies/Athos	Papaneophitos?	
I. 0835	17 th c. (1 <sup>st</sup> half)	No, at least 2nd	Greek-style binding	Karies/Athos	Papaneophitos?	
I. 1168	17 th c. (1 <sup>st</sup> half)	Yes	Flush pasteboard, unsupported binding	Karies/Athos	Papaneophitos?	
I. 1221	17 th c. (1 <sup>st</sup> half)	Yes	Greek-style binding	Karies/Athos	Papaneophitos?	

Table 161. Binding information.

Catalogue Number	Original binding?	Spine-fold Repair	Text-block Repair
I. 0393	No, at least 2nd	-	-
I. 0473	Yes	-	-
I. 0625	Yes	-	-
I. 0835	No, at least 2nd	Extensive, with western paper strips pasted locally and all through	Western paper strips pasted mainly in the edges
I. 1168	Yes	-	-
I. 1221	Yes	-	-

Table 162. Repair information.

Catalogue Nuber	Original binding?	Left endleaf unit arrangement	Right endleaf unit arrangement
I. 0393	No, at least 2nd	[?] 3	3 [?]
I. 0473	Yes	[1] 3	3 [1]
I. 0625	Yes	[1] 2+	+2 [1]
I. 0835	No, at least 2nd	[1] 3	+3 [1]
I. 1168	Yes	[2] 4	4 [2]
I. 1221	Yes	[1] 3	3 [1]

Table 163. Endleaves information. Red colour indicates features of the first, Papaneophitos, binding

Catalogue Num	Sewing Stations Number	Distance between stations / Pattern of sewing stations	Accommodation nicks	Sewing thread	Sewing thread thickness	Sewing thread twist	Sewing thread ply	Format of text-block	Thickness of text-block
I. 0393	4	10-62-59-60-20 / B2?	V-shape cuts	N.k.	N.k.	N.k.	N.k.	8vo	53
I. 0473	4	13-62-59-60-17 /B1	V-shape cuts	Linen	Thin	Loose	S	8vo	25
I. 0625	3	17-83-84-23 /B1	Small V-shape cuts	Linen	Medium	Medium	2(?) S	8vo	54
I. 0835	4	13-55-63-61-12 /B1	V-shape cuts	Linen	Thin	Medium	?S	8vo	37
I. 1168	4	11-45-42-43-11 /B1	V-shape cuts	Linen	Thin	Medium	2S	16mo	43
I. 1221	4	12-40-42-42-15 /B1	V-shape cuts	Linen	Thin	Tight	?S	16mo	55

Table 164. Sewing information. Red colour indicates features of the first, Papanecophitos, binding

Catalogue Number	Attachment system	Material	Dimensions	Boards edge groove	Spine edge treatment	Spine joints	Spine shape	Thickness of boards	Format of text-block	Thickness of text-block
I. 0393	N.k. (volume rebound)	N.k.	N.k.	N.k.	N.k.	N.k.	N.k.	9	8vo	53
I. 0473	I Uns / 10	Hardwood	Flush	BG 3	SET 4	120°	Round	7	8vo	25
I. 0625	II Uns / B1	Pasteboard	Flush	None	SET 1	Slight	Slight round	4	8vo	54
I. 0835	I Uns 10	Hardwood	Flush	BG 3	SET 4	120°	Round	7	8vo	37
I. 1168	II Uns /B2	Pasteboard	Flush	None	SET 1	None	Flat	3	16mo	43
I. 1221	I Uns /10	Hardwood	Flush	BG3	SET 4	120°	Slight round	8	16mo	55

Table 165. Boards information.

Catalogue Number	Format of text-block	Spine lining	Material	Thickness	Board covered	Side of boards covered	Boards Thickness
I. 0393	8vo	N.k. (volume rebound)	N.k.	N.k.	N.k.	N.k.	9
I. 0473	8vo	Yes all along the spine	Canvas?	Medium	60%	Outside	7
I. 0625	8vo	Yes all along the spine	Canvas	Medium	20%	Inside	4
I. 0835	8vo	Yes all along the spine	Canvas	Medium	50%	Outside	7
I. 1168	16mo	Yes all along the spine	Canvas	Medium	35%	Inside	3
I. 1221	16mo	Yes all along the spine	Canvas	Medium	50%	Outside	8

Table 166. Spine lining information

Catalogue Num	Number of cores	Endband primary sewing (E. P. S.) type	First core material	Second core material	First core thickness	Second core thickness	Distance of projection	Anchoring system
I. 0393	N.k.	Nk (volume rebound)	N.k.	N.k.	N.k.	N.k.	N.k.	N.k.
I. 0473	2	Wound plain on 1 <sup>st</sup> core	Cord	Thread	Medium	Thin	15 mm - 10,4%	EAS 2
I. 0625	1	Islamic on single warps	Leather	-	Medium	-	A few mm	EAS 6
I. 0835	2	Wound plain on 1 <sup>st</sup> core?	Cord	Thread	Medium	Thin	20 mm - 16%	EAS 2
I. 1168	2	Wound plain on 1 <sup>st</sup> core	Cord	Thread	Medium	Thin	6 mm - 6,2%	EAS 3?
I. 1221	2	Wound plain on 1 <sup>st</sup> core?	Cord	Cord	Medium	Medium	20 mm - 20%	EAS 2

Table 167. Endband cores information.

Catalogue Num	E. P. S. type	E. P. S. thread	E. P. S. thread colour	E. P. S. thread thickness	E. P. S. thread twist	E. P. S. thread ply	Number of tie-downs	Tie-downs position	Thread anchorage
I. 0393	N.k.	N.k.	N.k.	N.k.	N.k.	N.k.	N.k.	N.k.	N.k.
I. 0473	Wound plain on 1 <sup>st</sup> core	Hemp	Natural	Medium	Medium	?S	N.k.	Centre-fold	Uses change-over station
I. 0625	Islamic on single warps	Linen?/ Silk	Natural/ Yellow, red	Thin /medium	Tight/Medium	3S/2 sS	As many as gatherings	Centre-fold	Uses change-over station
I. 0835	Wound plain on 1 <sup>st</sup> core?	Linen	Natural	Thin	Tight	2S	As many as gatherings	Centre-fold	Uses other passing hole outside
I. 1168	Wound plain on 1 <sup>st</sup> core	Linen (SaS)	Natural	Thin	Medium	2S	N.k.	Centre-fold	Uses change-over station
I. 1221	Wound plain on 1 <sup>st</sup> core?	Linen (SaS)	Natural	Thin	Tight	?S	As many as gatherings?	Centre-fold	Uses change-over station

Table 168. Endband primary sewing information

Catalogue Number	Endband secondary sewing / weaving (E. S. E. / W.) type	E. S. S. / W. thread	E. S. S. / W. thread colours	E. S. S. / W. thread thickness	E. S. S. / W. thread ply	E. S. S. / W. thread twist
I. 0393	N.k.	N.k.	N.k.	N.k.	N.k.	N.k.
I. 0473	Embroidered 2-colours, front bead & crowning core	Silk	Yellow, red	Medium	2 sS	Medium
I. 0625	None	-	-	-	-	-
I. 0835	Embroidered 2-colours, front bead & crowning core	Silk	Yellow, red	Medium	2 sS	Medium
I. 1168	Embroidered 3-colours, front bead & crowning core	Silk, silver around silk	Yellow, red, Silver	Medium	2 sS	Medium
I. 1221	Embroidered 2-colours, front bead & crowning core	Silk	Yellow, red	Medium	2 sS	Medium

Table 169. Endband secondary sewing / weaving information

Catalogue Number	Marker	Primary marker	Primary marker material & colour	P. M way of attachment	Secondary marker	Secondary marker material & colour	Secondary M way of attachment
I. 0393	N.k. (rebound)	N.k.	N.k.	N.k.	N.k.	N.k.	N.k.
I. 0473	Compound	Simple open loop	Yellow silk (SaE)	LtH(f)	1 double, single-colour thread string, & 1 single, double-colour thread string	Natural hemp & yellow, brown silk twisted together	KiM, KiE
I. 0625	Compound (vestiges)	Compound closed loop wrapped	Cord core & yellow silk all around ?	LtH(f)	1 single, single-coloured thread string	Natural hemp	N.k. (detached)
I. 0835	Compound	Simple open loop	Yellow and red silk (SaE) twisted together	LtH(b)?	1 double, single-colour thread string	Cyan silk	KiM
I. 1168	Compound	Simple open loop	Red silk and metal thread (SaE) twisted together	LtH(f)	N.k. (missing)	N.k. (missing)	N.k.
I. 1221	Compound? (vestiges)	Unclear	Yellow silk (SaE)	N.k.	N.k. (missing)	N.k. (missing)	N.k.

Table 170. Markers information.

Catalogue Number	Cover material	Cover colour	Turn-ins type	Turn-ins width	Corner mitre
I. 0393	N.k.	N.k.	N.k.	N.k.	N.k.
I. 0473	Sheep? leather	Brown	T-ins 1	Medium	Co 1, Co 7
I. 0625	Goat leather	Black	T-ins 1	Variably wide	Co 1, Co 3
I. 0835	Goat? leather	Black	T-ins 1	Medium	Co 1
I. 1168	Goat leather	Brown yellow	T-ins 1	Medium	Co 1, Co 4
I. 1221	Goat leather	Deep Purple	T-ins 1, T-ins 3	Wide	Co 1, Co 7

Table 171. Cover information.

Catalogue Number	Left / Right difference ?	Decoration pattern	Spine decoration pattern	Board edges decoration pattern	Decoration motives	Number of tools
I. 0393	N.k.	N.k.	N.k.	N.k.	N.k.	N.k.
I. 0473	No	Dec 1a	None	BED 1	MuF/a14, MuF/c4, MuG/a6, CeF52, RoF3, RoG4, C11	7
I. 0625	No	Dec 12	None	None	MuF/a14, MuF/c4, MuG/a7, CeR23, CeR24, C10	6
I. 0835	No	Dec 1a	None	BED 2	MuF/a14, MuF/c4, MuG/a6, CeF52, RoF3, RoG4, C11	7
I. 1168	No	Dec 1a	None	None	MuF/a14, MuF/a38, MuF/c4, CeF52, RoG4, C11	6
I. 1221	No	Dec 1a	None	BED 2 (2rings)	MuF/a14, MuF/c4, MuG/a7, MuV2, RoF46, C11	6

Table 172. Decoration information.

Tool	Volumes where it is used	Number of volumes where it is used
MuF/a14	I. 473, I. 625, I. 835, I. 1168, I. 1221	5
MuF/a38	I. 1168	1
MuF/e4	I. 473, I. 625, I. 835, I. 1168, I. 1221	5
MuG/a6	I. 473, I. 835,	2
MuG/a7	I. 625, I. 1221	2
CeF52	I. 473, I. 835, I. 1168, I. 1221	4
CeR23	I. 625	1
CeR24	I. 625	1
RoF3	I. 473, I. 835	2
RoF46	I. 1221	1
RoG4	I. 473, I. 835, I. 1168	3
C10	I. 625	1
C11	I. 473, I. 835, I. 1168, I. 1221	4

Table 173. Tools information.

Catalogue Number	Number of Fastenings	Fastenings type	Fastenings material	Strap anchorage type	Turn-ins arrangement	Ends form	Arrangement of anchorage holes	Metal components
I. 0393	N.k. (rebound)	-	-	-	-	-	-	-
I. 0473	0-2-0 ←	Three edged leather interlaced straps / N.k.	SaC and metal	TBTP	F & T 8	UfaP	AH 4	Rings (M) & cast and filed metal compound pins
I. 0625	0-2-0 →←	Leather straps	SaC	TBTP	F & T 1	TpaP	AH 5	None
I. 0835	0-2-0 ←	Three edged leather interlaced straps / N.k.	SaC and metal	TBTP	F & T 8	UfaP	AH 4	Rings (M) & filed metal simple pins
I. 1168	0-2-0 ←	Two edged leather Turk's head knot and loop	SaC	TBT	F & T 1	UuP	AH 5	None
I. 1221	0-2-0 ←	Three edged leather interlaced straps / Standard type	SaC and metal	TBP	F & T 6	TfaP	AH 4	Rings & cast metal compound pins

Table 174. Fastenings information.

## THE COSMAS MACEDON BINDINGS

Catalogue Number	Text cronology/Date	Title/s	Scribe/s-Printer/s	Format of text- block	Number of leaves	Notes	Original binding
I. 0970	1686	Papadiki (M)	Cosmas Macedon	8vo (224 x 146)	351 WpP	Front flyleaf r. «Αρχή της παπαδικής χι' αχτισ' (1686 AD), Νοεμβρίου 27. Παπαδική α' του Κοσμά».	Yes
I. 0978	1680 ca.	Sticherarion (M)	Cosmas Macedon	8vo (230 x 136)	242 WpP		Yes
I. 0979	1680 ca.	Sticherarion (M)	Cosmas Macedon	8vo (252 x 126)	193 WpP		Yes
I. 0980	1680 ca	Mathimatarion (M)	Cosmas Macedon	8vo (230 x 145)	232 WpP		Yes
I. 1048	1686	Hirmologion (M)	Cosmas Macedon	8vo (232 x 144)	178 WpP		Yes
I. 1183	1692	Papadiki (M)	Cosmas Macedon	16mo (153 x 97)	294 WpP	f. 283 v. «εις τους αχρβ' (1692 AD) χειρ αμαρτωλού κοσμά εις το Ιβίρων φεβρουαρίου κδ'»	Yes
S. 1469	1689	Music (M)	Cosmas ek ton Iviron (Macedon?)	8vo (218 x 152)	377 WpP	f. 272 v. «εις τους αχπθ' (1689 AD) χειρ αμαρτωλού Κοσμά εις των Ιβίρων ένεκα πάντων δόξα σοι ο θεός ημών δόξα σοι.»	Yes
S. 1478	1690	Psaltiki (M)	Cosmas Macedon	16mo (172 x 115)	266 WpP	f. 261 v. «εις τους αχρ' χειρ αμαρτωλού Κοσμά εις το Ιβίρων» f. 1 r. «1750 Ιουλίου 20, η παρούσα ψαλτική του αγίου Θεοβαδίστου όρους σνά ήρθεν απο την πόλην του μακαρίου παπά κυρίλλου Λιμένου και ο ζενόσας αυτήν και κλέψας έστω αστηγόρητος.»	Yes

Table 175. Text-block information.

Catalogue Number	Original binding	Left endleaf unit arrangement	Right endleaf unit arrangement
I. 0970	Yes	[D], 1+	+1, [D]
I. 0978	Yes	[1] 1 Tipped	Tipped 1 [1]
I. 0979	Yes	[1] 3	3 [1]
I. 0980	Yes	[1] 5	+ 2 [1]
I. 1048	Yes	[1] 1 Tipped	Tipped 1 [1]
I. 1183	Yes	[1] 3	3 [1]
S. 1469	Yes	[D], 4	+ 9 [D] [1]
S. 1478	Yes	[1] 1	+ 1 [1]

Table 176. Endleaves information.

Catalogue Number	Number of sewing stations	Distance between stations/ pattern of sewing stations	Kind of Sewing	Accommodation nicks	Thickness of text-block	Format of text-block
I. 0970	5	23-31-64-61-31-20 /B6	Supported	Needle holes	45	8vo
I. 0978	6	13-25-47-55-49-30-12 /B4	Unsupported?	tiny V shape cuts	37	8vo
I. 0979	6	13-24-26-59-33-31-21 /B9	Unsupported	V shaped cuts	28	8vo
I. 0980	6	13-30-51-48-53-25-10 /B4	Unsupported	tiny V shape cuts	36	8vo
I. 1048	6	8-23-54-54-45-30-14 /B4	Supported?	V shaped cuts	26	8vo
I. 1183	4	11-42-42-42-11 /B1	Supported	tiny V shape cuts	28	16mo
S. 1469	5	17-45-44-45-44-24 /B1	Supported	Needle holes	57	8vo
S. 1478	5	12-33-42-41-30-11 /B1	Unsupported?	Small V shape cuts	35	16mo

Table 177. Sewing information.

Catalogue Number	Sewing thread	Sewing thread thickness	Sewing thread twist	Sewing thread ply	Number of sewing supports	Sewing supports	Thickness of supports	Type of supports
I. 0970	Linen?	Extra thin	Tight	2S	1-1-1	Cord?	Medium	Raised
I. 0978	Linen	Thin	Tight	2S	-	-	-	-
I. 0979	Linen	Thin	Tight	2S	-	-	-	-
I. 0980	Linen	Thin	Tight	2S	-	-	-	-
I. 1048	Linen	Thin	Tight	2S	1-1-1-1-1?	Cord?	Medium	Raised
I. 1183	Linen	Thin	Tight	2S	1-1	Cord?	Medium	Raised
S. 1469	Linen	Thin	Tight?	2?S	1-1-1	Cord?	Medium	Raised
S. 1478	Linen	Thin	Loose	2S	-	-	-	-

Table 178. Sewing thread and sewing supports information.

Catalogue Number	Attachment system	Dimensions	Material	Wood grain direction	Type of oblique squares	Spine edge treatment	Spine joints	Thickness of boards	Format of text-block	Thickness of text-block
I. 0970	Sup 15	Projecting	Hardwood	Horizontal	OS 2	SET 3	Slight	8	8vo	45
I. 0978	I Uns 10?	Projecting	Hardwood	Vertical	OS 2	SET 2	Slight	6-7	8vo	37
I. 0979	I uns 10	Projecting	Hardwood	Horizontal	OS 2	SET 2	Slight	5	8vo	28
I. 0980	I Uns 10	Projecting	Hardwood	Vertical	OS 2	SET 2	Slight	5	8vo	36
I. 1048	Sup 15?	Projecting	Hardwood	Horizontal	OS 2	SET 2	Slight	5	8vo	26
I. 1183	Sup 15	Projecting	Hardwood	Horizontal	OS 2	SET 2	Slight	5	16mo	28
S. 1469	Sup 15	Flush	Wood	Horizontal	OS 2	SET 3	Slight	7	8vo	57
S. 1478	I Uns 10?	Projecting	Hardwood?	Vertical	OS 2	SET 2	Slight	5	16mo	35

Table 179. Boards information.



Catalogue Number	Spine lining	Material	Thickness	Board covered	Side of boards covered	Spine shape	Thickness of text-block
I. 0970	N.v	N.k	N.k	N.k	-	Flat	45
I. 0978	N.v	Canvas	Medium	N.k	N.v	Flat	37
I. 0979	Yes, all along	Canvas	Medium	N.k	Outside	Flat	28
I. 0980	Yes, all along	Canvas	N.k	N.k	Outside	Flat	36
I. 1048	Yes, all along	Canvas	Medium	N.k	Outside	Flat	26
I. 1183	Yes between stations	Canvas	Medium	N.k	Outside	Flat	28
S. 1469	N.v	Canvas ?	N.k	N.k	N.k	Flat	57
S. 1478	Yes, all along	Canvas	Medium	N.k	Outside	Flat	35

Table 180. Spine lining information.

Catalogue Number	Catalogue number	Number of cores	Endband primary sewing type	First core material	Second core material	First core thickness	Second core thickness	Distance of projection	Anchoring system
I. 0970	S 0619	2	Wound plain on 1 <sup>st</sup> core	Cord	Cord	Medium	Thin	N.k	N.k
I. 0978	S 0629	2	Wound plain on 1 <sup>st</sup> core	Cord	Cord	Medium	Thin	12 mm 8,4%	EAS 9
I. 0979	S 0634	2	Wound plain on 1 <sup>st</sup> core	Cord	Cord	Medium	Thin	18mm 13,6%	EAS 9
I. 0980	S 0678	2	Wound plain on 1 <sup>st</sup> core	Cord	Cord	Medium	Thin	10 mm 6,4%	EAS 9
I. 1048	S 0803	2	Wound plain on 1 <sup>st</sup> core	Cord	Cord	Medium	Thin	12 mm 7,7%	EAS 9
I. 1183	S 0808	2	Wound plain on 1 <sup>st</sup> core	Cord	Cord	Medium	Thin	16 mm 15,2%	EAS 9
S. 1469	S 1110	2	N.k	Cord	Cord	Medium	Thin	23 mm 14,1%	EAS 2
S. 1478	S 1963	2	Wound plain on 1 <sup>st</sup> core	Leather twisted	Thread 2 2S	Medium	Thin	N.k	EAS 13

Table 181. Endband cores information.

Catalogue Number	Endband primary sewing type	Primary sewing thread	Thread thickness	Thread ply	Thread twist	Number of tiedowns	Tie-down position	Thread anchorage
I. 0970	Wound plain on 1 <sup>st</sup> core	Linen (S.a.S)	Extra thin	2S	Tight	As many as gatherings	Centre fold	Uses change-over station
I. 0978	Wound plain on 1 <sup>st</sup> core	Linen (S.a.S)	Fine	2S	Tight	As many as gatherings ?	Centre fold	Uses change-over station
I. 0979	Wound plain on 1 <sup>st</sup> core	Linen (S.a.S)	Fine	2S	Tight	N.k	Centre fold	Uses change-over station
I. 0980	Wound plain on 1 <sup>st</sup> core	Linen (S.a.S)	Fine	2S	Tight	N.k	Centre fold	Uses change-over station
I. 1048	Wound plain on 1 <sup>st</sup> core	Linen (S.a.S)	Fine	2S	Tight	N.k	Centre fold	Uses change-over station
I. 1183	Wound plain on 1 <sup>st</sup> core	Linen (S.a.S)	Fine	2S	Tight	Less than gatherings	Centre fold	Uses change-over station
S. 1469	N.v	Linen (S.a.S)	Fine	2S	Tight	Less than gatherings	Centre fold	Uses change-over station
S. 1478	Wound plain on 1 <sup>st</sup> core	Linen	Fine	2S	Tight	N.k	Centre fold	Uses change-over station

Table 182. Endband primary sewing information.

Catalogue Number	Endband secondary sewing type	Thread	E. S. S. colours	Thickness	Ply	Twist
I. 0970	Ivion (2 colours)	Silk	Blue, yellow	Fine	2Z	Tight
I. 0978	Ivion (2 colours)	Silk	Blue, yellow	Fine	2Z	Tight
I. 0979	Ivion (2 colours)	Silk	Blue, yellow	Fine	2Z	Tight
I. 0980	Ivion (2 colours)	Silk	Blue, yellow	Fine	2Z	Tight
I. 1048	Ivion (2 colours)	Silk	Blue, yellow	Fine	2Z	Tight
I. 1183	Embroidered front bead & crowning core (2 colours)	Silk	Blue, yellow	Fine	2Z	Tight
S. 1469	Ivion (2 colours)	Silk	Blue, yellow	Fine	2Z	Tight
S. 1478	Ivion (2 colours)	Silk	Blue, yellow	Fine	2Z	Tight

**Table 183. Endband secondary sewing information.**

Catalogue Number	Marker	Primary Marker	Primary Marker material & colour	Primary M way of attachment	Secondary Marker	Secondary M. material & colour	Secondary M. way of attachment
I. 0970	Compound	2 compound closed loops F	a) Yellow silk around cord core b) Blue silk around cord	FtH(f)	Missing	N.k.	N.k.
I. 0978	Compound	2 compound closed loops F	Yellow silk around cord core	FtH(f)	Missing	N.k.	N.k.
I. 0979	Compound	Compound closed loop F	Yellow silk around cord core	FtH(f)	Single colour string	Blue silk	KiE+Pi
I. 0980	Compound	2 compound closed loops F	Yellow silk around cord core	FtH(f)	Missing	N.k.	N.k.
I. 1048	Compound	1 Compound closed loop F	Yellow silk around cord core	FtH(f)	Single colour string	Red silk	KiE
I. 1183	Compound	1 Compound closed loop F	Yellow silk around cord core	FtH(f)	2 ribbons	Faded red silk	KiE
S. 1469	Compound	3 compound closed loops F	Yellow silk around cord core	FtH(f)	Two-colour string	White, red silk plied together	KiE
S. 1478	Simple	Two-colour string	Pink, white (?) silk	FH(a)?	-	-	-

**Table 184. Markers information.**

Catalogue Number	Cover material type	Colour	Turn-ins type	Corners mitre
I. 0970	Goat leather	Black	T-ins 1, T-ins 3	Co 1
I. 0978	Goat leather	Black	T-ins 1, T-ins 3	Co 1, Co 4
I. 0979	Goat leather	Black	T-ins 1, T-ins 3	Co 1, Co 4
I. 0980	Goat leather	Black	T-ins 1, T-ins 3	Co 1, Co 4
I. 1048	Goat leather	Black	T-ins 1, T-ins 3	Co 1, Co 4
I. 1183	Goat leather	Black	T-ins 1, T-ins 3	Co 1, Co 4
S. 1469	Goat leather	Brown	T-ins 2?	Co 1, Co 6
S. 1478	Goat? leather	Dark brown	T-ins 1	Co 3

**Table 185. Cover information.**

Catalogue Number	Left/Right difference?	Decorative patterns	Spine decoration schema	Square's decoration	Type of decoration	Decoration motifs	Number of tools used
I. 0970	No	Dec14a	No	Blind tool fillets	Blind tooled	MuF/a5, RoF48, CeF58, CeR11, CoF4, fillets	6
I. 0978	No	Dec14a	No	Blind tool fillets	Blind tooled	MuF/a28, RoG6, CeF5, CoF3, fillets	5
I. 0979	No	Dec14a	No	Blind tool fillets	Blind and gold(?) tooled	MuF/a15(?), RoG6, CeF13, CoF21, fillets	5
I. 0980	No	Dec14a	SD2/B + tools	Blind tool fillets	Blind tooled	MuF/a12(?), MuF/a29, RoG6, CeF5(?), CoF21, fillets	6
I. 1048	No	Dec14a	SD2/B + tools	Blind tool fillets	Blind tooled	MuF/a24?, MuF/a29, RoF48, CeF36, CeR29, CoF3, fillets	7
I. 1183	No	Dec14a	SD2/B	No	Blind tooled	MuF/a37?, RoG7, CeF19, CeR11, CoF4, fillets	6
S. 1469	No	Dec14a	SD2/B + tools	Blind tool fillets	Gold tooled	MuF/a37, MuF/a41, MuF/b21, MuF/b22, RoG16, CeR35, CeR38, CoF11, CoR11, CoR12, CoR13, CoR14, fillets	13
S. 1478	No	Dec14a	No	Blind tooled roll	Blind tooled	MuF/a5, RoG7, CeF9, CeR11, CoF4, fillets	6

Table 186. Decoration information.

Tool	Volumes where it is used	Number of volumes where it is used
MuF/a5	I. 970, S. 1478	2
MuF/a12	I. 980	1
MuF/a15?	I. 979	1
MuF/a24?	I. 1048	1
MuF/a28	I. 978	1
MuF/a29	I. 980, I. 1048	2
MuF/a37	I. 1183, S. 1469?	2
MuF/a41	S. 1469	1
MuF/b21	S. 1469	1
MuF/b22	S. 1469	1
RoF48	I. 970, I. 1048	2
RoG6	I. 978, I. 979, I. 980	3
RoG7	I. 1183, S. 1478	2
RoG16	S. 1469	1
CeF5	I. 978, I. 980?	2
CeF9	S. 1478	1
CeF13	I. 979	2
CeF19	I. 1183	1
CeF36	I. 1048	1
CeF58	I. 970	1
CeR11	I. 970, I. 1183, S. 1478	3

CeR29	I. 1048	1
CeR35	S. 1469	1
CeR38	S. 1469	1
CoF3	I. 978, I. 1048	2
CoF4	I. 970, I. 1183, S. 1478	3
CoF11	S. 1469	1
CoF21	I. 979, I. 980	2
CoR11	S. 1469	1
CoR12	S. 1469	1
CoR13	S. 1469	1
CoR14	S. 1469	1
Fillets	All volumes	8

Table 187. Tools information

Catalogue Number	Titling position	Title
I. 0970		
I. 0978	Handwritten in the three external edges	Σεπτέμβριος, Οκτώμβριος/ΚΤ' (Κτήμα?) Νοέμβριος Δεκέμβριος ΚΜ' (Κοσμά Μακεδόνα?) Μαθηματάρων(?) (Head/Fore edge/ Tail)
I. 0979	Handwritten in the three external edges	Ιανουάριος, Φεβρουάριος/Μάρτιος, Απρίλιος, Μάιος, Ιούνιος / Ιούλιος κ' Αγίουστος (Head/Fore edge/ Tail)
I. 0980	Handwritten in the three external edges	Τριώδιον και / Πεντηκοστήριον/ [...] Head/Fore edge/ Tail
I. 1048		
I. 1183	Handwritten in the three external edges	Της Παπαδικής / τόμος Β' Κυπριανού ευτελοῦς (Head/Fore edge/ Tail)
S. 1469		
S. 1478	Handwritten in the three external edges	Τριώδιον/ αντίφωνα/ [...] /1690 (Head/Fore edge/ Tail)

Table 188. Titling information.

Catalogue Number	Number of fastenings	Fastening type	Fastenings material	Strap anchorage type	Strap type	Fastenings & T-ins arrangement	Hook Type	Hook & Strap attachment system	Catch plate / pin type	Catch plate attachment
I. 0970	0-2-0	Three edged leather interlaced straps pin & ring	Leather, metal (modern imitation)	TBT	-	F & T 6	-	-	Simple cast	-
I. 0978	0-2-0	Holed metal sheet and pin	S.a.C. metal	SuC	Trimmed double pasted	F & T 6	SMiE	HSAS 1	Simple cast	-
I. 0979	0-2-0	Holed metal sheet and pin	S.a.C. metal	SuC	Trimmed double pasted	F & T 6	SMiE	HSAS 1	Simple cast	-
I. 0980	0-2-0	Holed metal sheet and pin	S.a.C. metal	SuC	Trimmed double pasted	F & T 6	SMiE	HSAS 1	Simple cast	-
I. 1048	0-2-0	Holed metal sheet and pin	S.a.C. metal	SuC	Trimmed single	F & T 2?	SMFiE	HSAS 1	Simple cast	-
I. 1183	0-2-0	Hook and catch plate	S.a.C. metal	SuC	Trimmed double pasted	F & T 6	SMiE	HSAS 1	TnMSwB?	SuC
S. 1469	0-2-0	Hook and catch plate	S.a.C. metal	SuC	Trimmed double pasted	F & T 6	SMiE	HSAS 2	TnMSwB	SuC
S. 1478	0-2-0	Hook and catch plate.	S.a.C. metal	SuC	Trimmed double pasted	F & T 6	N.k (missing)	N.k (missing)	TnMSwS	SuC

Table 189. Fastenings information.



Three-edged leather interlaced starp

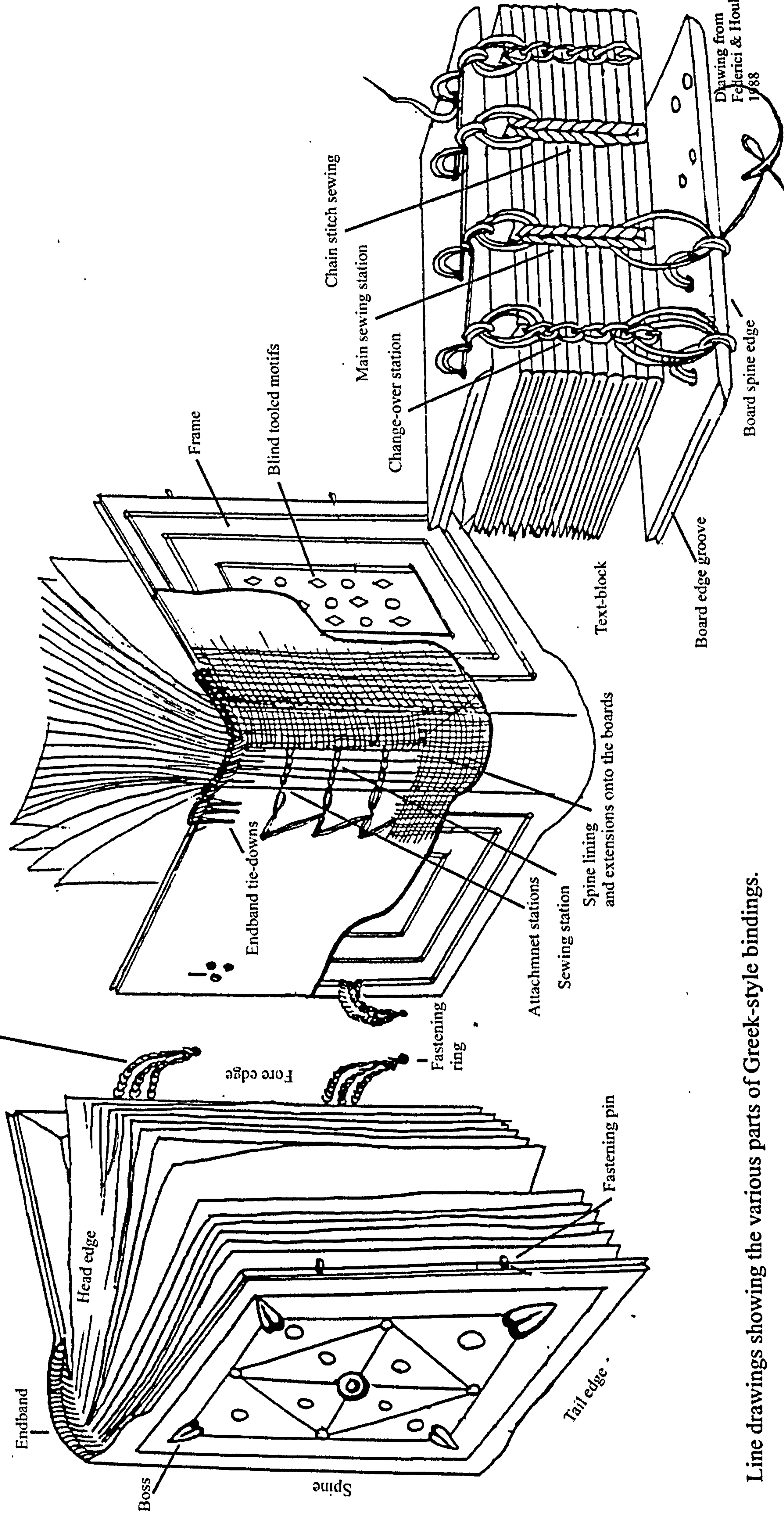

Drawing from  
Federici & Houlis  
1988

Line drawings showing the various parts of Greek-style bindings.

**Appendix 4**

## THE SURVEY FORM

What follows are the titles of all the fields included in the survey form of the database in the order presented in it, and all necessary clarifications about their significance, the information that they should contain and any codification of this information whenever necessary.

Bold letters indicate the title of each field. This can be slightly changed or presented in codified form in the actual layout of the survey form due to reasons of space and clear presentation. Square brackets indicate the type of each field (see figure in page 746) The various options in look-up fields are often followed by a codified short version between brackets, which were used both in the database, and the analytic tables included in the thesis in order to economize space. Brackets are also some times used when specific criteria need to be established in order to clarify things, as for example in designating the formats of the text-blocks according to their height. In some cases footnotes are used in order to clarify more complicated definitions like in the various options in the 'Type of Binding' field.

**GENERAL INFORMATION.** includes the following fields:

**Record Number** [Auto enter]: indicates an automatically increasing number that is added every time a survey form of the database is compiled. In this way every book surveyed has its own unique record number that distinguishes it from any other book contained in the database.

**Date of Entry** [Auto enter]: indicates the date that a bound volume has been surveyed.

**Library** [Look-up field]: the name of the library where the surveyed volume belongs

Iviron Monastery Library – Mount Athos, Greece,  
St. Catherine's Monastery Library – Sinai, Egypt.



**Catalogue Number** [Free text]: indicates the catalogue number that each bound volume examined has in each monastery's own catalogue.

For the Iviron monastery an 'I' before the number indicates the number of the manuscript with respect to the Lambros Catalogue, which includes the first 1386 manuscripts of the collection. For the manuscripts that are not included in this catalogue numbering continues from the number 1386 onward.

For books belonging to the St. Catherine's Monastery Library an 'S' before the catalogue number refers to Sinai followed by the number of the internal catalogue of the library used for all research needs. Normally after the 'S' another letter follows indicating the language in which the manuscript is written: 'S. Gr.' For Sinai Greek, 'S. A.' for Sinai Arabic, 'S. S.' for Sinai Syriac, 'S. Ge', for Sinai Georgian, etc.

**TEXT-BLOCK INFORMATION** includes the following:

**Kind of Book** [Look-up field]: indicates if the bound book examined contains a manuscript or a printed text-block. Though the research was exclusively confined to manuscript books this division was necessary because in some exceptional cases printed books had to be surveyed too as they were found to be bound in binding ateliers and from binders who were identified as responsible for the bindings of manuscript books.

Manuscript,

Printed,

Manuscript & printed.

**Title** [Free text]: indicates the title/s of the text/s of the book surveyed. After the title the general subject of the text is recorded between brackets according to the following list based on the Politis classification (Πολίτης 1961):

T for Theological,

M for Music,

C for Classics,

L for Liturgical,

H for History,

O for Other.

**Scribe/s** [Free text]: indicates the name/s of scribe/s who were involved with the writing of the book surveyed if known. In the case that the whole book or some part of it is printed and the printer can be identified, then his name is recorded here as well. The prefix *papa-* in the names of various scribes, binders etc (for example Papasophronios, Papanephitos etc) denotes their priestly office in vernacular Greek (*papas*).

**Date of Copy** [Free text]: indicates the date in which the text-block surveyed has been copied. In order to facilitate the classification and filtering of data in the database, dates are written with the number of century preceding any other indication in words: 16th c., 16th c. 1<sup>st</sup> half of, 17th c. early, 17<sup>th</sup> c. 1<sup>st</sup> quarter of, etc. When a text-block contains more than one part written in different periods than both dates are recorded, later dates coming first since they most probably reflect the date of the rebinding of the text-block. Dates for the manuscripts with no scribal note or other indication for the time of their production are based on information given mostly by published catalogues (the Kamil, Benesevich, Garthausen, Weitzman and Galavaris, for the Sinai library and the Lambros, Sotiroudis for the Iviron library) and other relevant literature, but also by the librarians and this holds true especially for father Theologos of the Iviron monastery with his extensive knowledge of the collection.

**Place of Copy** [Free text]: indicates the place where the manuscript was copied when discernible through notes or bibliography.

**Writing Support** [Look-up Field]: indicates the material of the writing support. This is a general statement serving only as an indication, with no aim for precise codicological documentation. The characterization is based on visual and quality characteristics such as the presence or not of watermarks, chain- and wire-lines, quality and aspect of fibers, caliper etc. Burnishing of the surface, a feature of Eastern papers, is an indication of provenance only for pre-sixteenth century papers, since for later periods on Greek manuscripts, it was a common habit to burnish Western paper, probably as an influence from Turkey.

Western paper,

(W.P.)

Western polished paper,	(W.p.P.)
Eastern paper,	(E.P)
Eastern polished paper,	(E.p.P)
Various papers,	(V.P.)
Paper,	(Pap)
Paper & Parchment	(Pap & Par)
Parchment.	(Par)

**Quality of Writing Support [Look-up Field]:** gives a general statement about the quality of the writing support. This field will record its original quality whenever the state of preservation does not compromise such evaluation, in which case a general statement on the preservation is recorded between brackets:

Bad,  
Normal,  
Fine,  
Excellent,  
Varies,  
(Badly preserved),  
(Superficial dirt and grime).

**Caliper [Look-up Field]:** indicates the relative thickness of the single leaves of the text-block. As in the previous field, this is also a general statement based only on visual observation and touch of the writing support caliper, meant only as an indication:

Thin,  
Medium,  
Thick.

**Watermarks [Free text]:** Indicates with a 'Yes' or 'No' any visible watermarks. If their subject is visible this is mentioned, and if identification is critical for dating the manuscript or the binding also the Briquet Catalogue number is recorded if identifiable, or a reference to the closest similar one. Therefore

normally there is no expectation for precise codicological information, this field will serve only as a general indication.

**Format [Look-up Field]:** format is used here in the broader sense of the word in order to indicate the general proportions and the approximate size of a book and should not be confused with the meaning the word has when referring to the folding of flat printed sheets into gatherings. The format of the text-block is followed by the actual dimensions of the leaves between brackets.

Folio (height of gatherings exceeding 381 mm.),  
4to (height of gatherings between 281-380 mm.),  
8vo (height of gatherings between 201-280 mm.),  
16mo (height of gatherings between 151-200 mm.),  
24mo (height of gatherings between 101-150 mm.),  
32mo (height of gatherings smaller or equal to 100 mm).

**Text-block Thickness [Free text]:** indicates the total thickness in millimeters only of the text-block, without considering the thickness of the boards.

**Number of Leaves [Free text]:** indicates the total number of leaves of the text-block including endleaves and pastedowns, even when the manuscript foliation does not include them. The number of leaves results from adding the foliated leaves of each book and the non-foliated endleaves whenever this is the case. No checking of the correctness of the existing foliation has been done.

**Number of Gatherings [Free text]:** indicates the number of gatherings whenever such number is easily discernible.

**Former Owner, Collection, or Place of Keeping Inside the Monastery [Free text]:** indicates if the manuscript belonged to other persons or collections before becoming part of the monastery's library. Whenever notes on a manuscript refer to a specific place inside the monastery where it should or was kept, like the *katholicon*, or other chapel, this is recorded here as well.

**Date of Entrance to the Monastery [Free text]:** indicates the date when the book, in its present binding or not, entered one of the two monasteries of the research. This date is sometimes discernible through notes on the books. This evidence can be of help in attributing a binding to a workshop of the two monasteries considered here, though we have to consider that the movement of books from the monasteries in other places and back seems to have been a rather common habit.

**Patronage or Donation [Free text]:** indicates the name of a person who paid for the production of the book or donated the book to either of the monasteries. In the latter case the name is written between brackets. Again, notes on the manuscripts are the source for such information.

**Bibliography [Free text]:** The basic bibliography that exists for the volume surveyed. Normally refers to the printed catalogues where the manuscript is published or any other major article making reference to it.

**Notes [Free text]:** Transcripts in original language, but not in original accent, of any relevant note on the text-block or volume such as owner's notes, copyist's notes etc.

**GENERAL BINDING INFORMATION** includes the following fields:

**Type of binding [Look-up Field]:** a general designation which is based on the typological entity of the binding. This is a conventional way for designating bindings according to their most prominent technical features. On this basis the following type of bindings have been recorded in this research:

Greek-Style Byzantine binding<sup>126</sup> .

---

<sup>126</sup> Indicates the Greek-style bindings of the Byzantine period, i.e. until 1453 A. D. For latest published work where the features of Greek-style bindings are summarised see Szirmai 1999 pp. 62-92, with all previous bibliography. Concisely, these bindings are distinguished by the unsupported sewing or chain stitch, the peculiar attachment between the boards (which are always cut flush to the text-block) and the

Greek-Style post-Byzantine binding<sup>127</sup>.  
 Islamic binding with fore-edge flap<sup>128</sup>  
 Islamic binding without a fore-edge flap  
 Greek-Islamic bindings<sup>129</sup>  
 Flush pasteboards, with supports binding<sup>130</sup>  
 Flush pasteboards, unsupported binding<sup>131</sup>  
 Projecting pasteboards with supports binding<sup>132</sup>  
 Projecting pasteboards, unsupported binding<sup>133</sup>  
 Projecting wooden boards, with supports<sup>134</sup>  
 Sewn text-block no boards and cover,  
 Unbound gatherings within wrapper,  
 Stitched pamphlet,

---

text-block, the boards edge grooves, the peculiar 'Greek-style' endbands which always extend onto the boards and protrude from the head and tail edges of the book, and the interlaced fastenings. See line drawings in the beginning of Appendix 4

<sup>127</sup> Indicates a Greek-style binding that was made in the post-Byzantine era, i.e. generally speaking ranging from after the fall of the Byzantine Empire in 1453 until the constitution of the modern Greek state in 1821. In this type of bindings some deviations from the standard structure may occasionally be found such as the use of supports in a binding which for the rest conforms perfectly with the typology of Greek-style bindings. See also Boudalis, 'One Research – two Libraries: surveying bindings of the late 15<sup>th</sup> - 17<sup>th</sup> century in the libraries of the Iviron monastery / Mount Athos and the St. Catherine's monastery / Sinai. Two Methodological Approaches', in postprints of the Colloque international *La reliure médiévale* Paris, Institut de France, 22-24 Mai 2003, which will be published by Brepols in 2004.

<sup>128</sup> Indicates a binding which follows the standard Islamic technical and decorative features, as these have been established from the twelfth – thirteenth centuries onward, such as the unsupported, chain stitch sewing, the use of pasteboards, the typical Islamic, woven, endbands, the attachment between the boards and the text-block which is made by means of adhesive only, and the very characteristic fore-edge flap which extends from the right board, etc. There are also some characteristic decorative features. See for example J. A. Szirmai 1999 pp. 51-61 and G. Bosch. et al Chicago, 1981.

<sup>129</sup> Indicates hybrid binding structures which combine two basic Islamic structural features, the Islamic endbands and the attachment of the text-block with the boards through an attachment system of the II Uns type, therefore normally bound in pasteboards, with a non Islamic decoration or a decoration which may be strongly influenced by Islamic prototypes but can be attributed with some certainty to a non Muslim binder. Further more they are normally sewn on three or at the most four sewing stations. Whenever the endbands are not typical Islamic but still the II Uns attachment system is used they are considered as Flush pasteboard unsupported bindings. See also Μπουδαλής 2004.

<sup>130</sup> Indicates a hybrid binding structure in which the pasteboards are flush to the text-block (as in 'Greek-style' and Islamic bindings) but the sewing is done on supports which are used in order to attach the text-block to the pasteboards.

<sup>131</sup> Indicates hybrid binding structures in which the sewing of the text-block is unsupported and the attachment of the text-block to the pasteboards is made using either I Uns or II uns attachment systems, though in the latter case without the other features of Greek-Islamic bindings (see also note 129 above)

<sup>132</sup> Indicates binding structures with projecting pasteboards and text-blocks sewn on supports which are used in order to attach the text-block to the pastedowns.

<sup>133</sup> Indicates hybrid binding structures with projecting pasteboards and text-blocks sewn unsupported. Attachment between text-block and pasteboards can be achieved either through bridling or through adhesive. (see the Giglio bindings in section 2.2.2.).

<sup>134</sup> Indicates binding structures with projecting wooden boards and text-blocks sewn on supports which are used to attach the text-block to the boards.

Uncertain.

For those bindings which in the course of the research proved to belong to a distinct workshop like those described in the main text of the research, a second designation between brackets has been added at a later stage, indicating the name of the workshop in which the binding was made.

**Place of Binding [Free text]:** The place where the binding was made either directly discernible through notes, or indirectly through comparison with other identified bindings, tools etc. A question mark is often used here to indicate probability and uncertainty.

**Date of Binding [Look-up Field]:** If the exact date of execution of the binding is not discernible, then the approximate date of binding is recorded. Whenever the date of copy of manuscript is known and the binding itself is the original one, then that date should be recorded here with a question mark. It is supposed that even if they are not exactly contemporary they will be close in date.

16<sup>th</sup> c, 1<sup>st</sup> quarter of  
16<sup>th</sup> c, 2<sup>nd</sup> quarter of  
16<sup>th</sup> c, 3<sup>rd</sup> quarter of  
16<sup>th</sup> c, 4<sup>th</sup> quarter of  
16<sup>th</sup> c, 1<sup>st</sup> half of  
16<sup>th</sup> c, 2<sup>nd</sup> half of  
17<sup>th</sup> c, 1<sup>st</sup> quarter of  
17<sup>th</sup> c, 2<sup>nd</sup> quarter of  
17<sup>th</sup> c, 3<sup>rd</sup> quarter of  
17<sup>th</sup> c, 4<sup>th</sup> quarter of  
17<sup>th</sup> c, 1<sup>st</sup> half of  
17<sup>th</sup> c, 2<sup>nd</sup> half of  
18<sup>th</sup> c, 1<sup>st</sup> quarter of  
18<sup>th</sup> c, 2<sup>nd</sup> quarter of  
18<sup>th</sup> c, 3<sup>rd</sup> quarter of  
18<sup>th</sup> c, 4<sup>th</sup> quarter of  
18<sup>th</sup> c, 1<sup>st</sup> half of  
18<sup>th</sup> c, 2<sup>nd</sup> half of .

**Binder's Note [Yes/No]:** 'Yes' if there is a written note on the book recording the person and/or the date and place of binding of the book.

**Binder [Free text]:** indicates the name of the binder if known or discernible. If unknown but still probably of a known binder the name of the binder should be recorded followed by a question mark.

**Note [Free text]:** transcript of any notes in the volume dealing with the binding of the volume in original language but not in original word accent.

**Binding Height [Free text]:** indicates the binding's height in millimeters. In the case where endbands are anchored on the boards and protrude from its edges

-like in Greek-style Byzantine and post-Byzantine bindings, but also in other 'hybrid' Greek bindings of the period examined- two measures should be taken, the first for the boards plus the extensions of the endbands on both sides, and the second only for the boards. For example 370/350. When there is no binding, either because the manuscript never had one or due to damage this field is left empty.

**Binding Width [Free text]:** indicates firstly the total width of the binding from the acme of the spine to the fore edge and secondly the actual width of the board from the spine edge of the boards to the fore edge in millimeters. If the binding has endbands anchored on the boards and extending onto its edges, as in Greek-style bindings, then a third measure should be recorded,

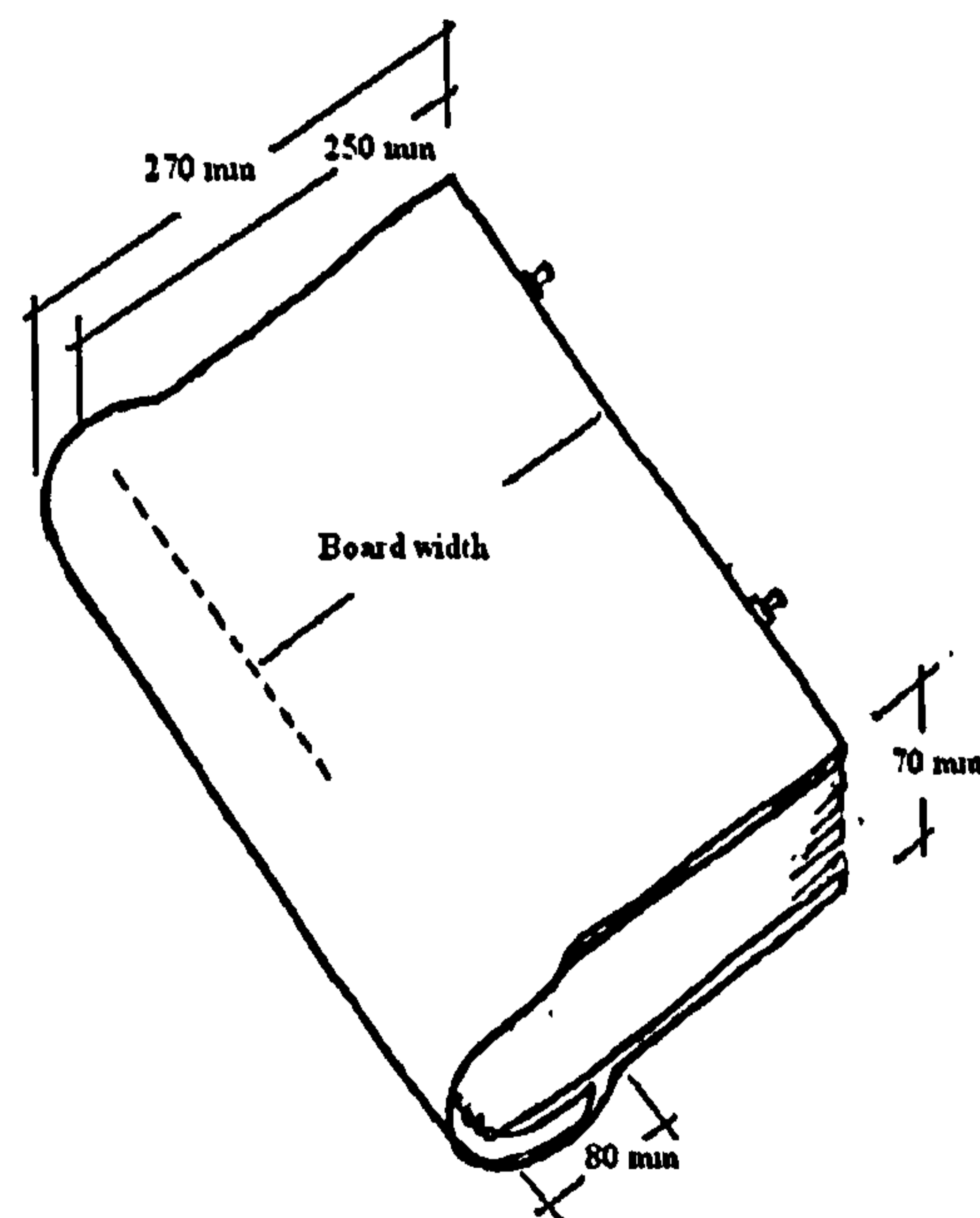
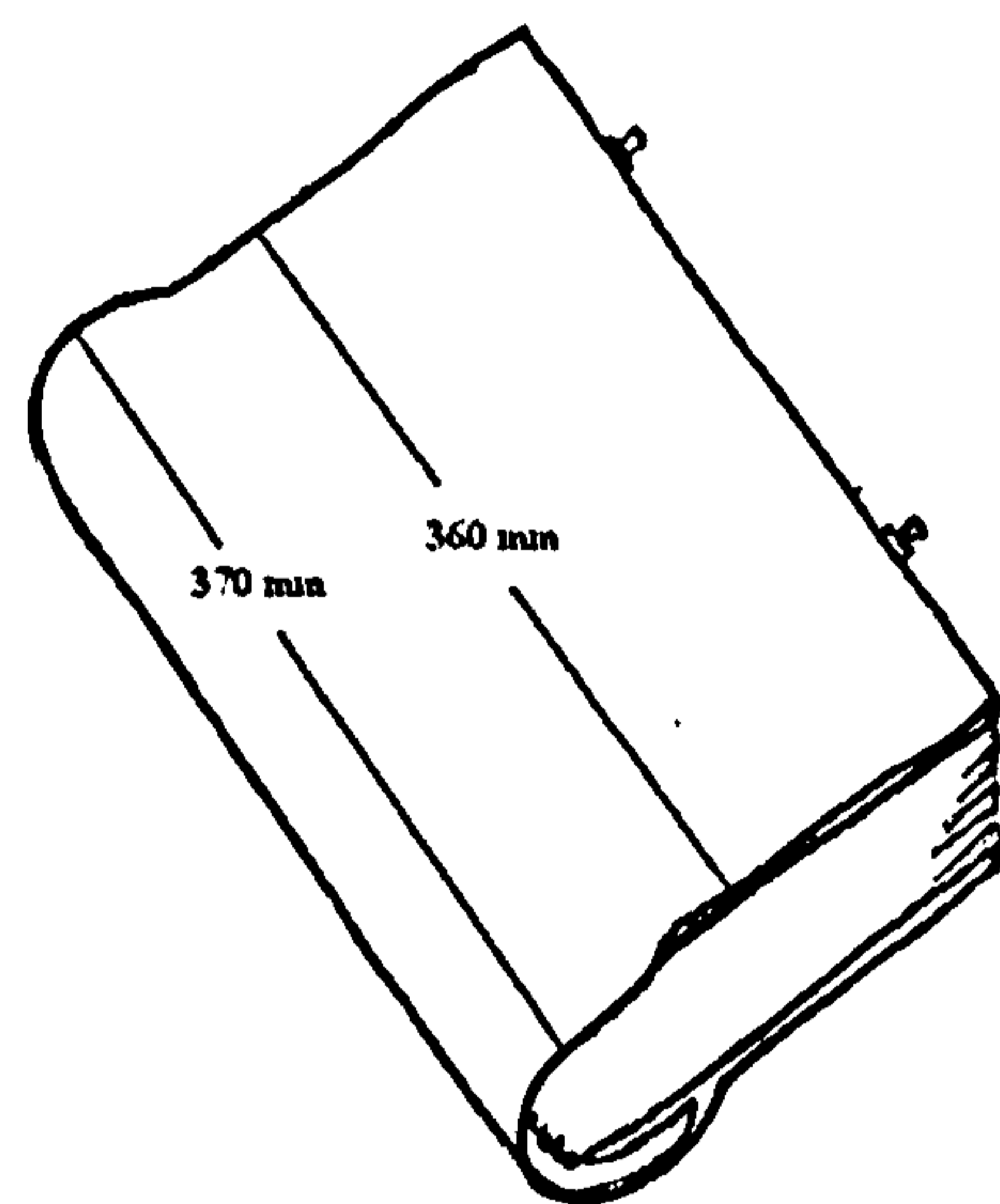



referring to the width from the acme of the board spine edge to the point where the projection of the endbands onto the boards ends. For example 270/250/80 mm. Whenever such length of extension is not the same for all four endbands' extensions then the average is recorded.

**Binding Thickness [Free text]:** indicates the thickness of the binding, boards included, in millimeters. When there are considerable irregularities in the thickness, for example swollen or deformed boards, then two measures are recorded corresponding to the smallest and biggest thickness. In books with no boards 'Nk' is recorded in this field.

**Text-block Repair [Look-up Filed]:** Indicates if there is evidence of repair on the text-block leaves and the relative time of execution in respect to the binding of the volume.

Yes, part of (re)binding,

Yes, after (re)binding,

Yes, during and after (re)binding,

No,

Not known (N. K.)

**Text-block Repair Material [Free Text]:** indicates the material used for the repair of the text-block leaves.

**Spine-fold Repairs [Look-up Filed]:** Yes if there is repair or reinforcement of the spine folds or spine edge of the gatherings, bifolia, or leaves.

Yes, part of (re)binding,

Yes, after (re)binding,

Yes, during and after (re)binding,

No,

Not known (N. K.)

**Spine-fold Repairs Type/Material** [Free Text]: indicates the material used for the repair/reinforcement of the spine folds of the gatherings, bifolia, or single leaves, as well as the type of repair/reinforcement (pasted-over locally, pasted-over all along, connecting trimmed along the spine conjugate leaves etc). In the case that stitching has been used for this purpose, the kind of stitching (overcasting, running stitch etc) precedes the designation of the stitching thread.

**Unused V Shape cuts** [Yes/No]: if there are any unused V shape cuts, this is recorded, as it is a clear evidence of an earlier sewing structure.

**Original Binding?** [Look-up Field]: indicates if the present binding is the original, that is the first binding a text-block ever had, one or not as it can result from the above mentioned indications. 'Yes, Partly' is used to indicate compound text-blocks, i.e. consisting of at least two text-blocks written in different dates and bound together, the later of which is normally contemporary to the present binding. Some of the most obvious clues which might indicate that a binding is the original or not are for example the presence of unused V shape cuts, repairs in the spine-folds of the gatherings, as well as a series of other features such as the decoration, the endbands etc, which nevertheless require a rather extensive familiarity of the researcher with all the features of a specific type of binding and their presence in time.

Yes,

Yes, partly,

Probably,

No, at least second,

Not known (N. K.)

**Binding Repaired?** [Look-up Field]: indicates if the present binding of the book has been repaired:

No,

Yes, modern repair,

Yes, old repair.

**Type of Repair** [Free Text]: indicates the type of repair, e.g. overback, new cover, reattachment of a detached board etc.

### ENDLEAF INFORMATION:

Endleaves are considered the blank leaves that precede and follow the text-block, either as separate gatherings or as part of the outermost gatherings of the text-block. The term indicates both flyleaves and pastedowns when these are structurally connected with the flyleaves or the text-block gatherings either by sewing them with the text-block or hooking them around the outermost text-block gatherings.

The term 'unit' is introduced in order to allow separate consideration of front and back endleaves even in the context of the same volume and a statistic processing of the research results. The term is conventionally used since in some cases endleaves are part of the outermost text-block gatherings and therefore they cannot really be considered as separate units. It describes the number of blank leaves and the way they are arranged in the two ends of the text-block. The terms 'left' and 'right' is used to distinguish between the endleaf units of a bound text-block, referring to the relative position of the endleaf units when keeping a book open in front of the reader. This term is used instead of 'front' and 'back' to avoid confusion since Arabic manuscripts have been recorded as well, for which front and back of the text-block are reversed in respect to Greek manuscripts. Five more terms are used to further categorize endleaves:

The term **compound** indicates an endleaf unit having both at least one pastedown and at least one flyleaf. The term **simple** indicates an endleaf unit having only either one pastedown or one flyleaf at least. The term **separate** indicates an endleaf unit which consists of a gathering of blank leaves connected through sewing or adhesion to one or both ends of the text-block. The term **separate & added** indicates a separate endleaf unit which has been added to one or both ends of the text-block after its binding, normally by pasting the pastedown and/or tipping the endleaf/s along the spine-fold. The term **integral** indicates an endleaf unit which consists of a part of the outermost gathering/s which have been left blank and used either as compound or simple endleaves. Leaves which are hooked around one or more text-block gatherings are considered as integral. Any paper or other material pasted in the inside of the boards above the turn-ins, not sewn or

otherwise connected with the text-block (though in cases it may extend and be pasted on the recto of the first flyleaf), is considered a **doublure** and is recorded separately (see below).

The following fields are included:

**Endleaves Presence [Yes/No]:** a preliminary statement about the presence or not of endleaves.

Yes,

No

**Endleaf Units Difference [Yes/No]:** 'Yes' if there is a difference between the front and back endleaf units in their number of leaves, material, or arrangement.

Yes,

No

**Concordance [Look-up Field]:** indicates the relation of the endleaves material with that of the text-block.

Same material as text-block, (S.a.TB.)

Different material than text-block, (D.t.TB)

Partly the same material as text-block, (P.S.a.TB.).

**Size [Look-up Field]:** indicates the endleaves size compared to the size of the text-block leaves:

Full size,

Full size with deckles,

Undersize,

Undersize with deckles,

Oversize

**Watermarks [Free Text]:** As in the corresponding field in the 'Text-Block' section above.

**Left Endleaf Unit Material:** indicates the material of the left endleaf unit. Whenever the endleaves material is identical with that of text-block, one of the three first choices is selected, otherwise any material recorded is meant as different from that of the text-block. In the option 'Partly the same as text-block', this statement is followed by the type of the diverse material between brackets. Information in this field may repeat information already recorded in the field "Concordance" described above, but as said before that field serves mainly as a field for sorting and filtering data according to that feature only.

Same as text-block ,	(S.a.TB.)
Partly same as text-block,	(P.S.a.TB)
Same as text-block, unpolished,	(S.a.TB. unpolished)
Western paper,	(W.Pap)
Western polished paper,	(W.P.Pap)
Eastern paper,	(E.Pap)
Eastern polished paper,	(E.P.Pap)
Parchment,	(Par)
Eastern paper Ms. Waste,	(E.Pap.MS.W)
Western paper Ms. Waste,	(W.Pap.MS.W.)
Parchment Ms. Waste,	(Par.MS.W)
Decorated paper,	(D.Pap)
None,	
Not known	(N. K.)

**Left Endleaf Unit Arrangement [Free Text]:** indicates the total number of left endleaves and the way they are arranged in a codified way.

The description of the arrangement follows a left to right direction starting from the pastedown of the left board and ending with the pastedown of the right board.

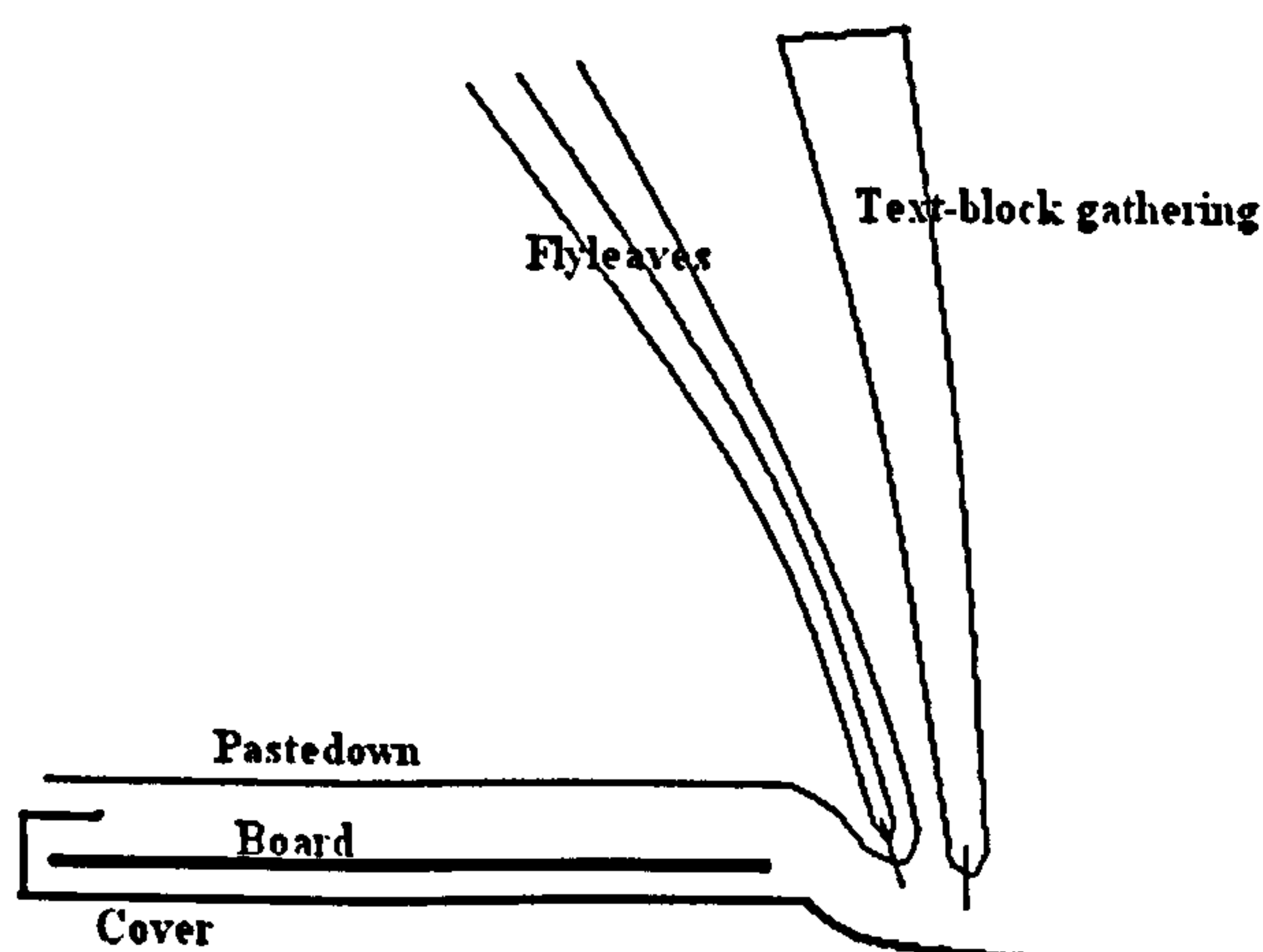

The arrangement [1]3

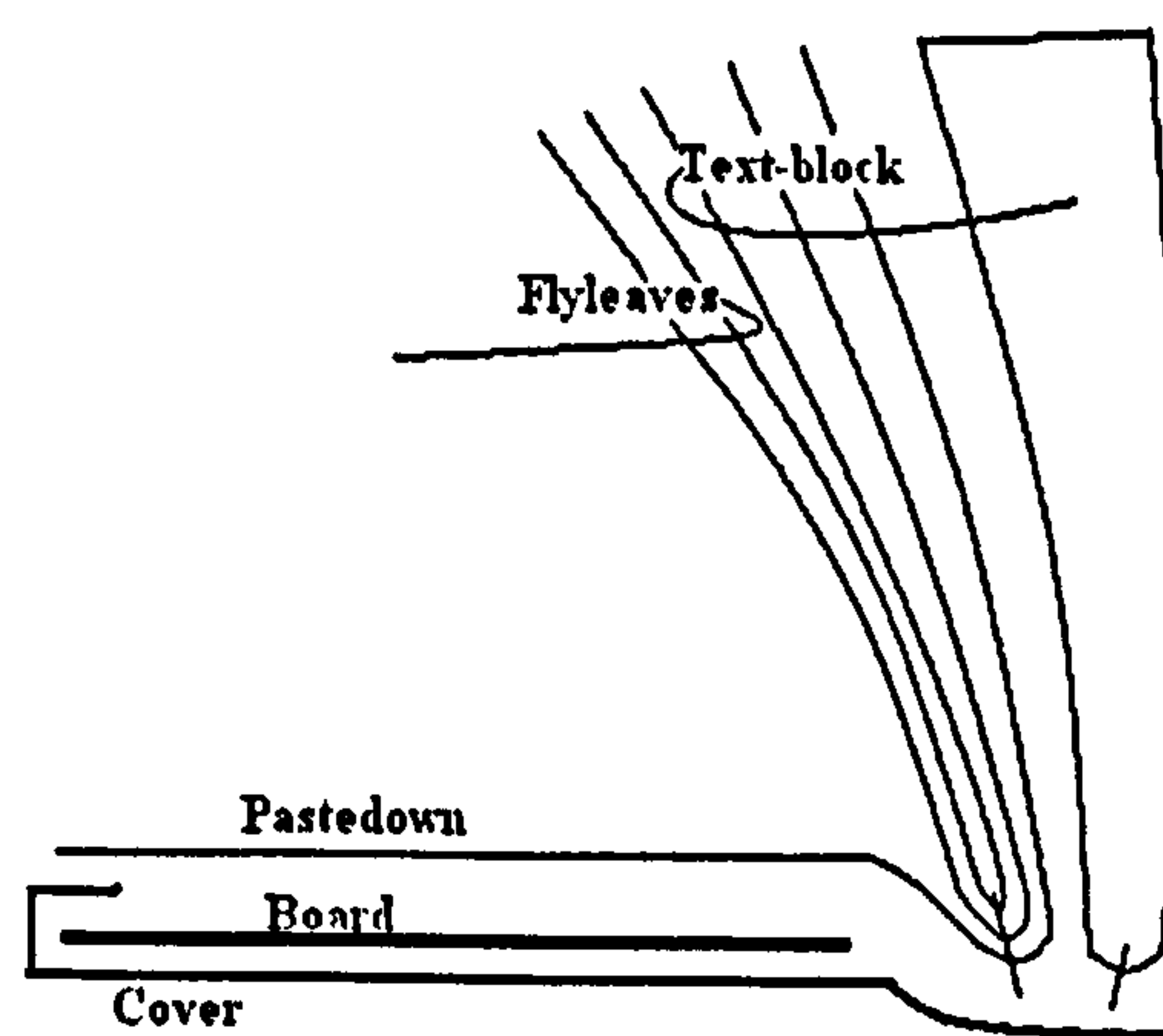

The arrangement [1]2 +

Therefore the arrangement '[1] 3' codifies a structure of left endleaf unit which consists of a separate gathering, of which the first leaf is a pastedown, while the remaining three are fly leaves, as shown in the drawing

Whenever endleaves are not separate but integral to the text-block a '+' sign follows the codified description. So the arrangement '[1] 2 + 3' refers to a structure like the one shown in the drawing above. Whenever endleaves are made up of a separate gathering but also of some of the leaves of the 1<sup>st</sup> text gathering, then a '+' sign precedes the number of blank flyleaves belonging to the text gatherings.

In cases where leaves are hooked, then the signs '/' '\ ' and '\u039b' are used to as shown in the drawings

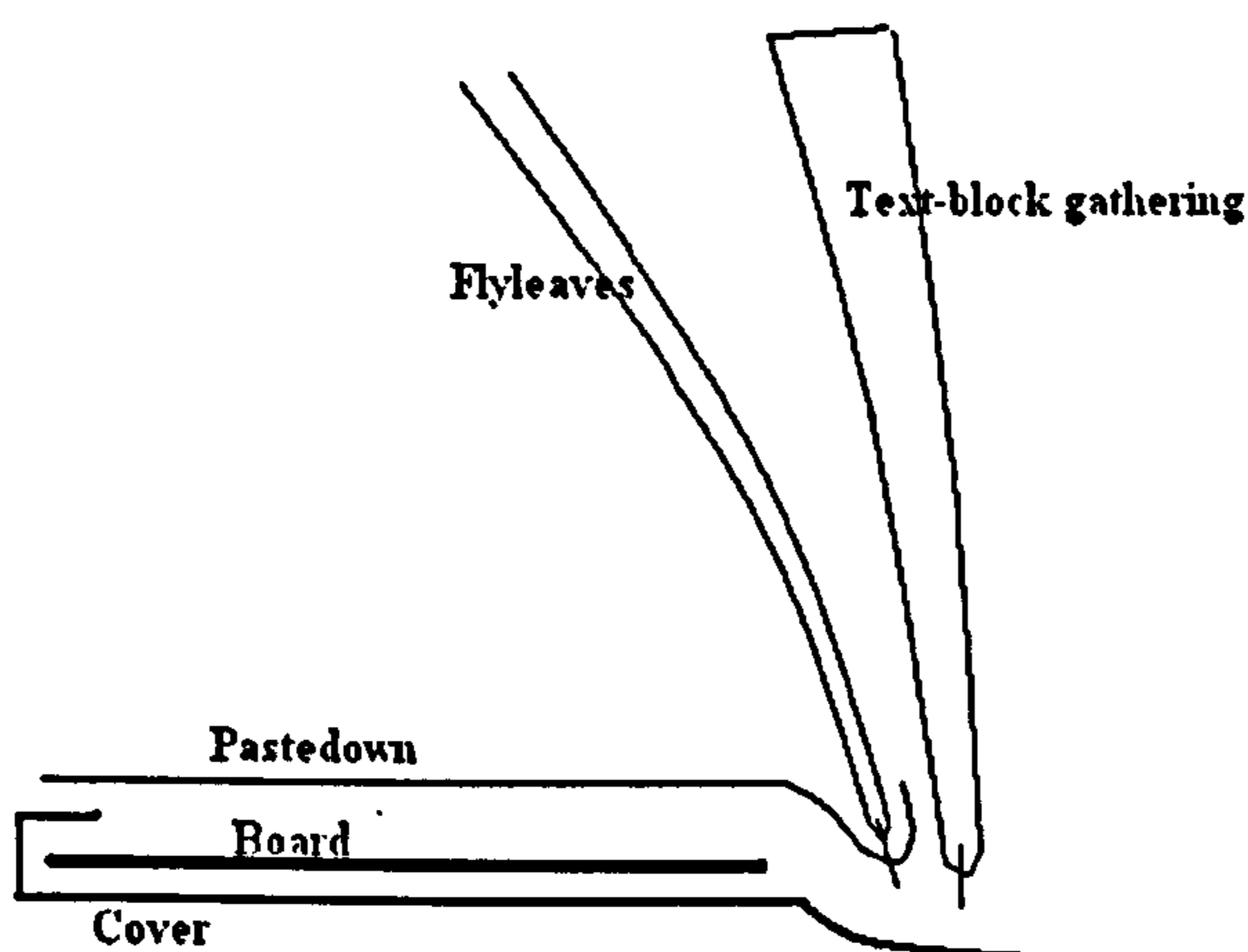

The arrangement [1] 2 f/

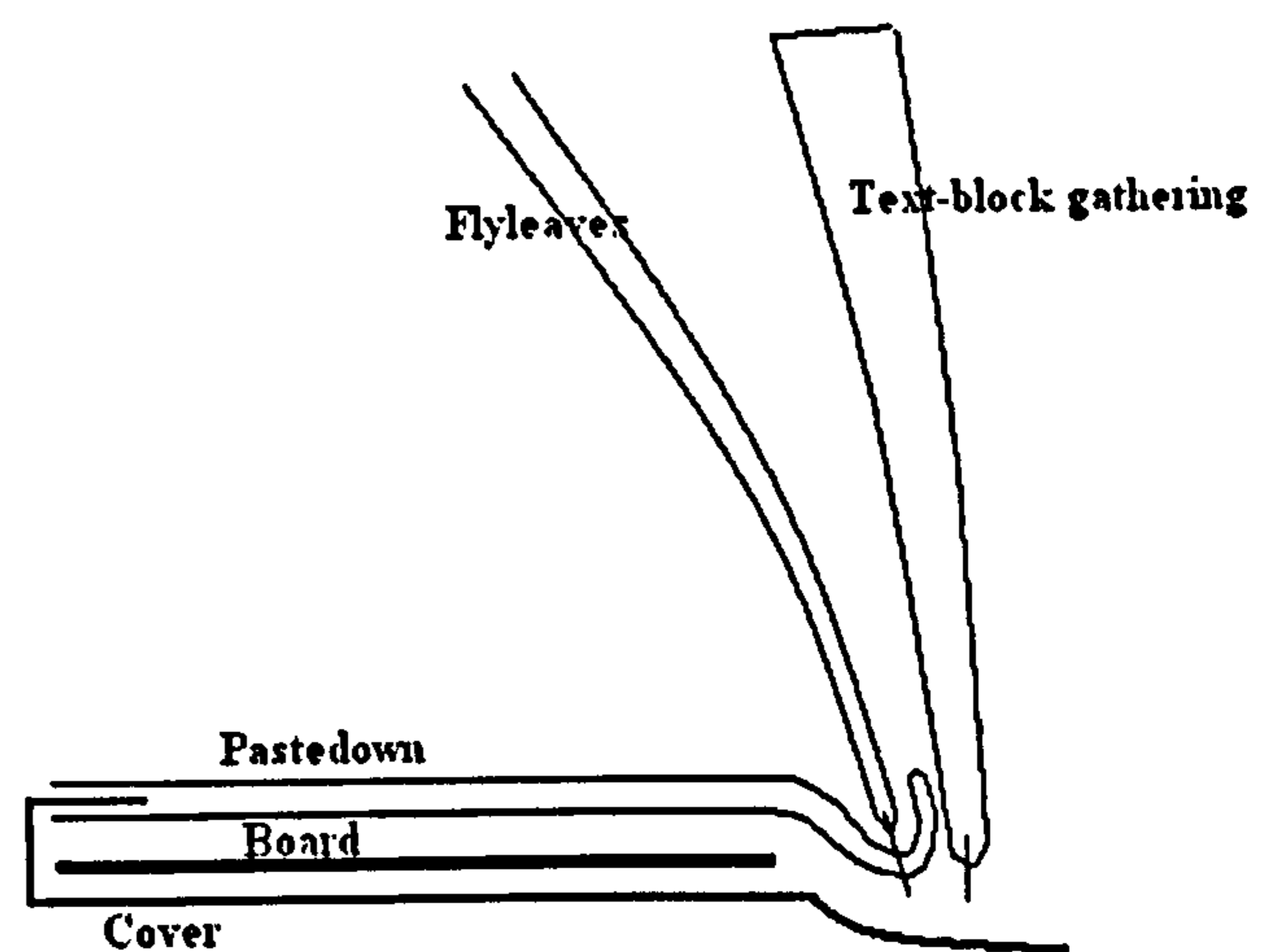

The arrangement [2] 2 \u039b

If hooks are free this is indicated with an 'f' : [1] 2 f/. If the hook is pasted this is indicated with a 'p' from the pasted side: [1] 2 p / or [1] 2 / p. The former indicates that the stub is pasted in the verso of the second flyleaf, whilst the later indicates that the stub is pasted in the recto of the following leaf. In this case the first leaf of the text-block which is not shown in the formula. A doublure is indicated with the letter 'D' inserted in the formula in the relative position it has

in it. So the formula [1] D 3 describes the arrangement shown in the drawing below:

The arrangement [1] D 3

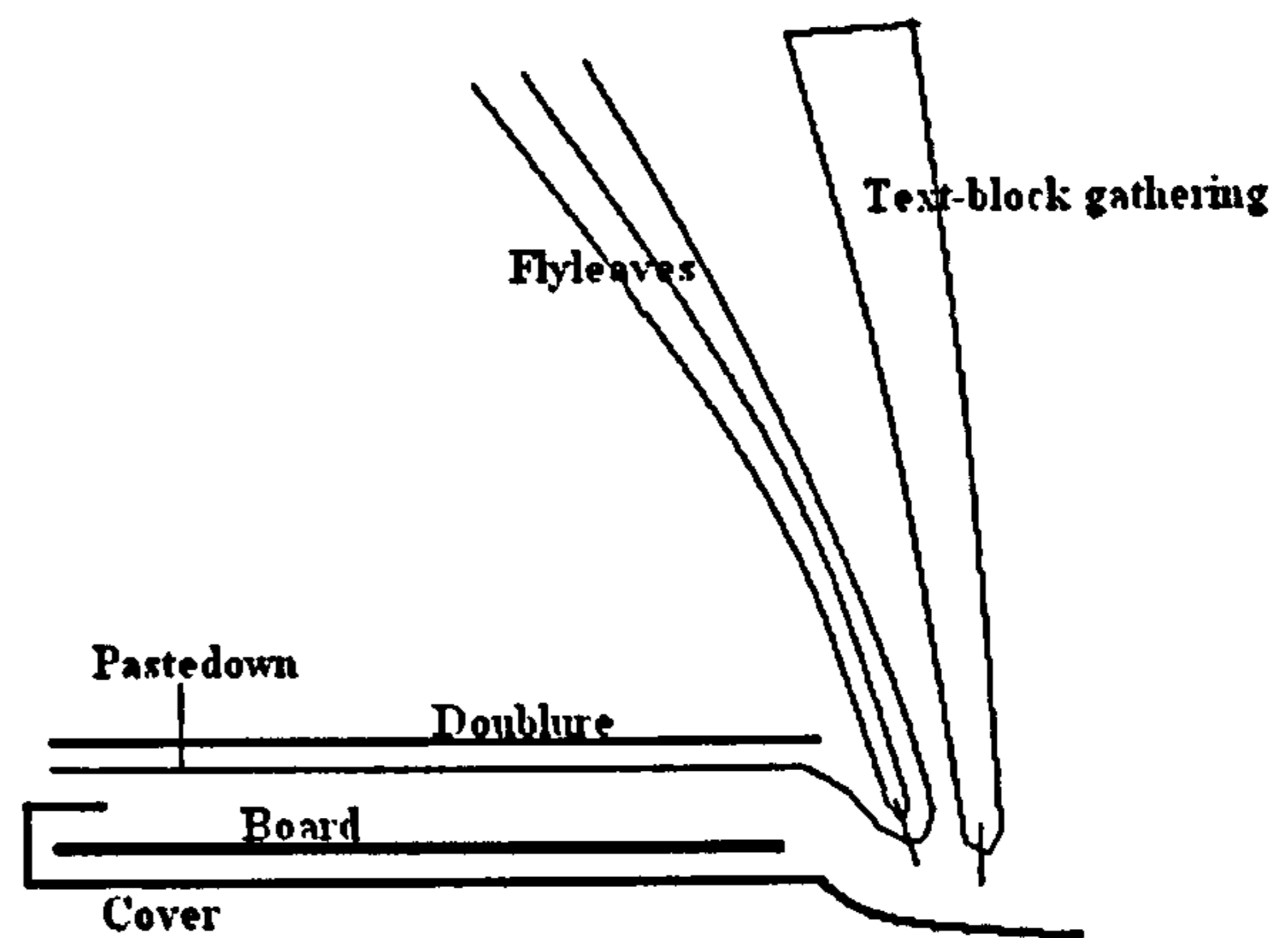

A question mark is used whenever the arrangement of the endleaves is not clear.

**Left Endleaf Unit Arrangement Notes [Free Text]:** in this field any further, supplementary information regarding the arrangement of the endleaf unit is recorded such as the way the pastedowns are attached etc. It will often contain description of endleaf arrangement which cannot satisfactorily be described by the aforementioned conventions. Such descriptions, supplemented with drawings made when surveying the book, can lead to a better understanding and therefore description of unusual and complicated endleaf arrangements, and ultimately to the invention of new conventions for their description.

**Right Endleaf Unit Material:** indicates the material of the right endleaf unit. Whenever the endleaves material is identical with that of text-block, one of the three first choices is selected, otherwise any material recorded is meant as different from that of the text-block. In the case of 'partly the same as text-block', this statement is followed by the type of the different material between brackets. For the rest what has already been mentioned in the "Front Endleaves material" field is also valid here.

Same as text-block,

(S.a.TB.)

Partly same as text-block,

(P.S.a.TB.)

Same as text-block, but non polished,	(S.a.TB. unpolished)
Western paper,	(W.Pap)
Western polished paper,	(W.P.Pap)
Eastern paper,	(E.Pap)
Eastern polished paper,	(E.P.Pap)
Parchment,	(Par)
Eastern paper Ms. waste,	(E.Pap.MS.W)
Western paper Ms. waste,	(W.Pap.MS.W.)
Parchment Ms. waste,	(Par.MS.W)
Decorated paper,	(D.Pap)
Modern cerulean paper,	(M.C.Pap)
None,	
Not known	(N.k.)

**Right Endleaf Unit Arrangement**[Free Text]: indicates the total number of right endleaves in a codified way, pastedowns included. This field follows the same descriptive method as the aforementioned “Left Endleaf Unit Arrangement” field, keeping only in mind that numbering of endleaves is reversed, starting the description from flyleaves and ending with pastedowns. Thus the formula 3 [1] will describe a structure like the one shown in the drawing below on the left. For the rest the same rules and conventions are used though in reversed sequence. For example the formula +1, \ 4 [1] will describe the arrangement shown in the drawing below on the right.

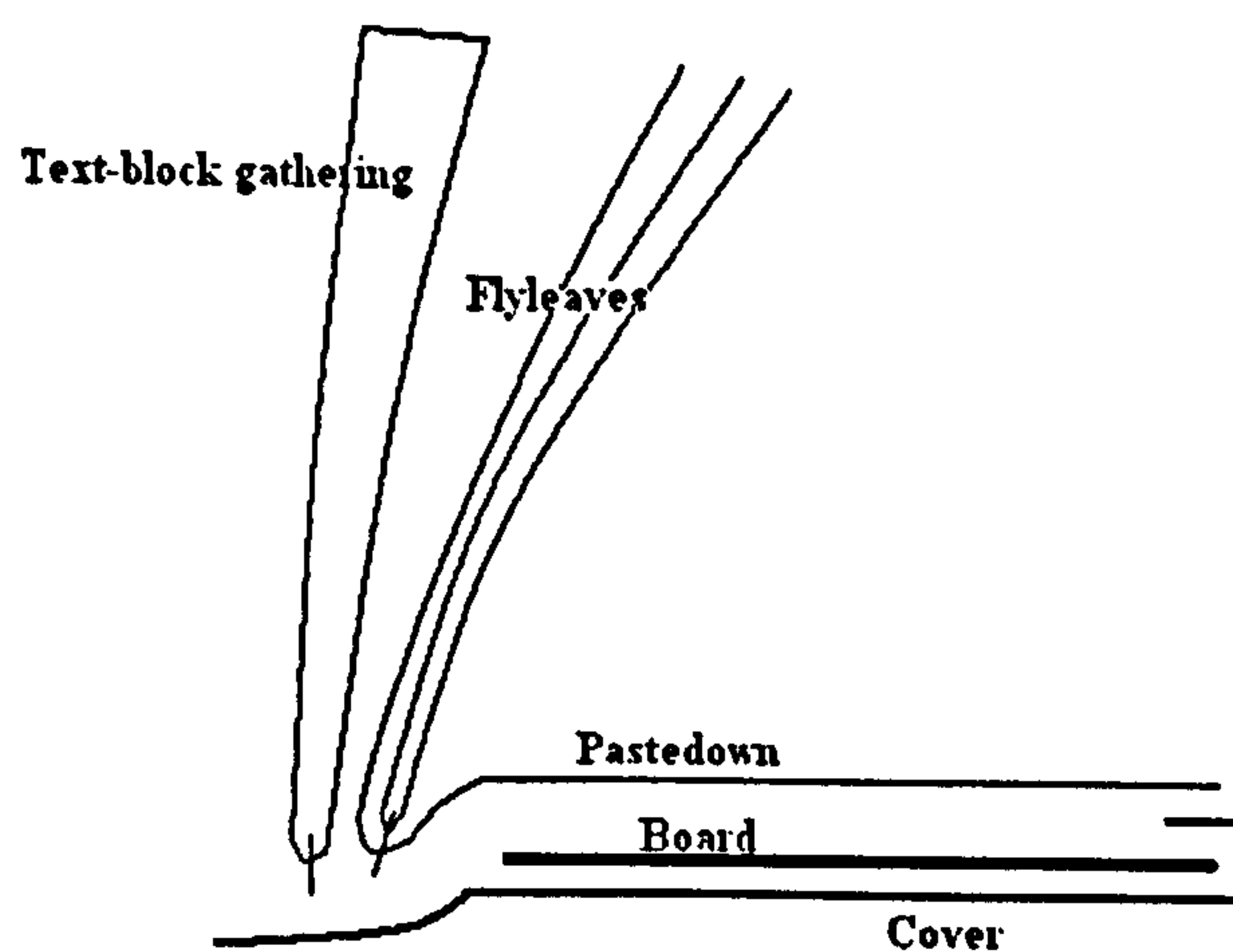

The arrangement 3 [1]

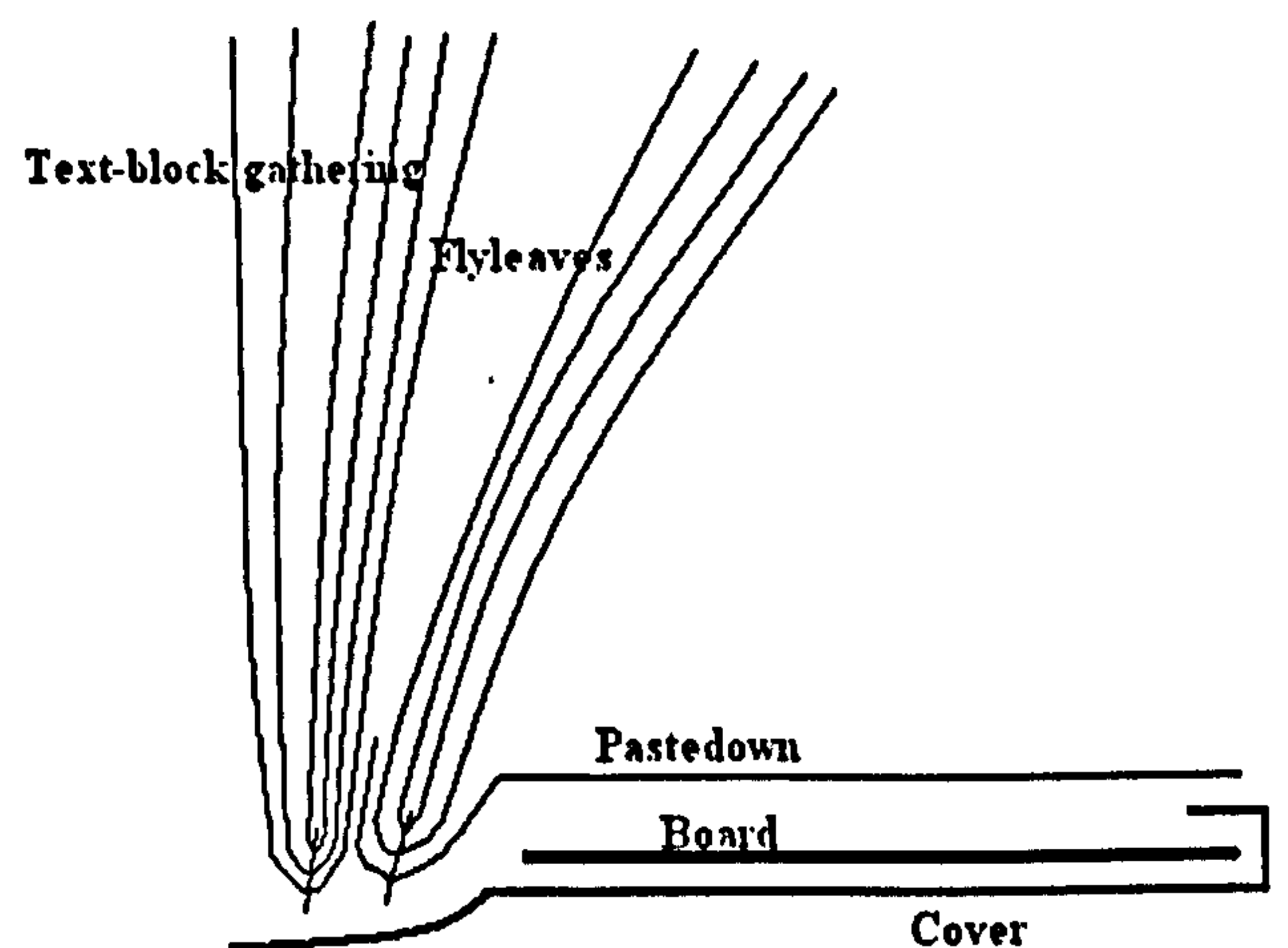

The arrangement +1, \ 4 [1]



**Right Endleaf Unit Arrangement Notes:** as above in the “Left Endleaf Unit Arrangement Notes” field.

**Pastedowns size:** indicates the size of the pastedowns with respect to the text-block.

Full size,

Full size with deckles,

Undersize,

Undersize with deckles,

Oversize.

**Doublure Type [Look-up Field]:** will indicate the type of doublure. The following three different types have been recorded:

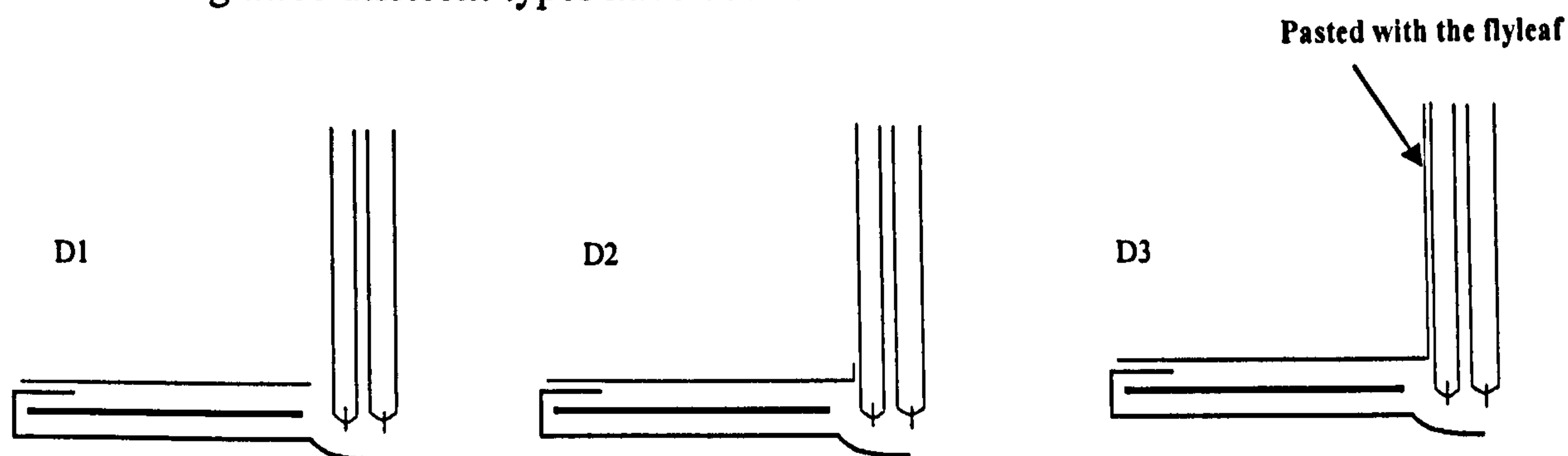

**Doublure Material [Free Text]:** indicates the material used for the doublure.

**Decorated Paper [Yes/No]:** a general statement about the presence or not of decorated paper in the endleaf units or doublures. It is used as a quick way to sort the database records according to this feature. If ‘Yes’ is selected further information about the type and the arrangement will be provided in the endleaves or doublure fields explained above, whilst colours are recorded in the following field.

**Colours of the Decorated Paper [Free Text]:** indicates the colours of the decorated paper.

**Pastedown under Turn-ins?** [Look-up field]: indicates if any of the pastedowns is pasted under the turn-ins. This feature as said above (see footnote 129) is typical of Greek-Islamic bindings.

Yes

No

Partly

**Way of Attachment:** indicates the way pastedowns are pasted on the inside of the boards.

Yes all over,

All around,

Random,

Detached,

Not known

(N. K.)

**Type of Adhesive** [Free Text]: indicates the type of adhesive used to adhere the pastedowns on the boards, if this is discernible.

**SEWING INFORMATION** includes the following fields:

**Preliminary Sewing:** indicates if there is any stitching of the gatherings prior to the proper sewing of the gatherings, evident either by the presence of the actual sewing structure, or by unused needle holes in the outermost spaces between the change-over stations and text-block's edges that cannot be the holes of the endband tie-downs.

None,

Head/tail spine fold loop at one station  
(Petherbridge 1991. p. 377),

Central spine fold loop at two stations  
(Petherbridge 1991. pp. 377-8),

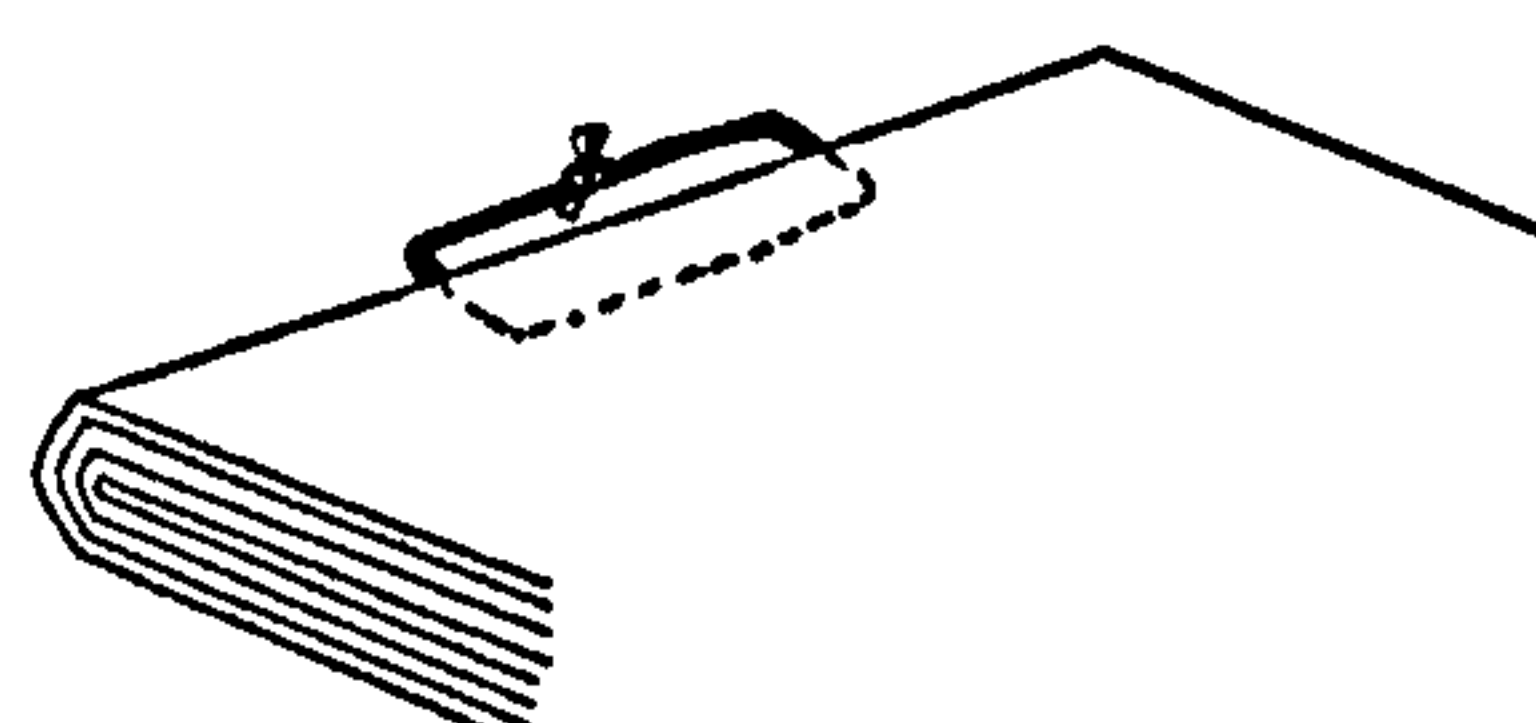
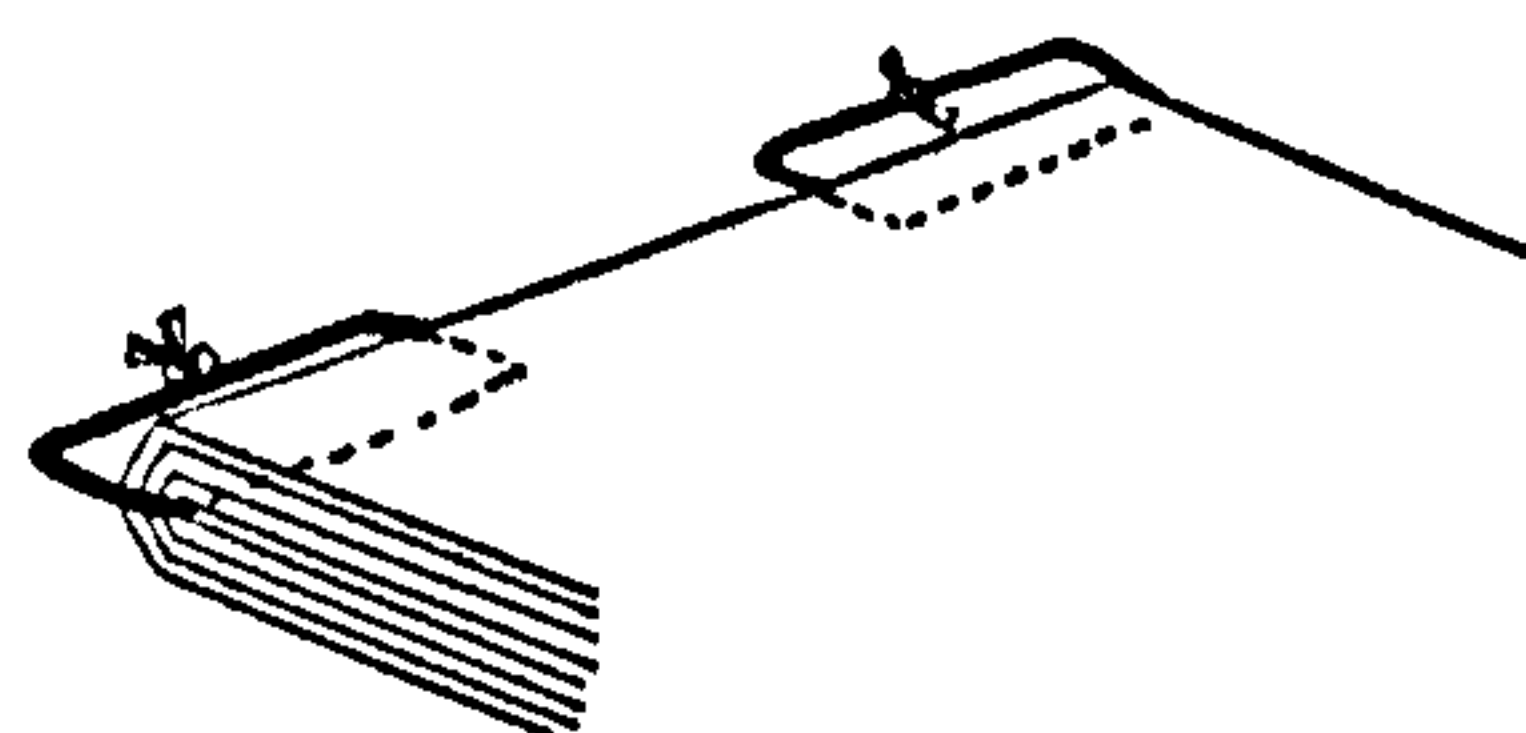

Overcasting, /-shape,

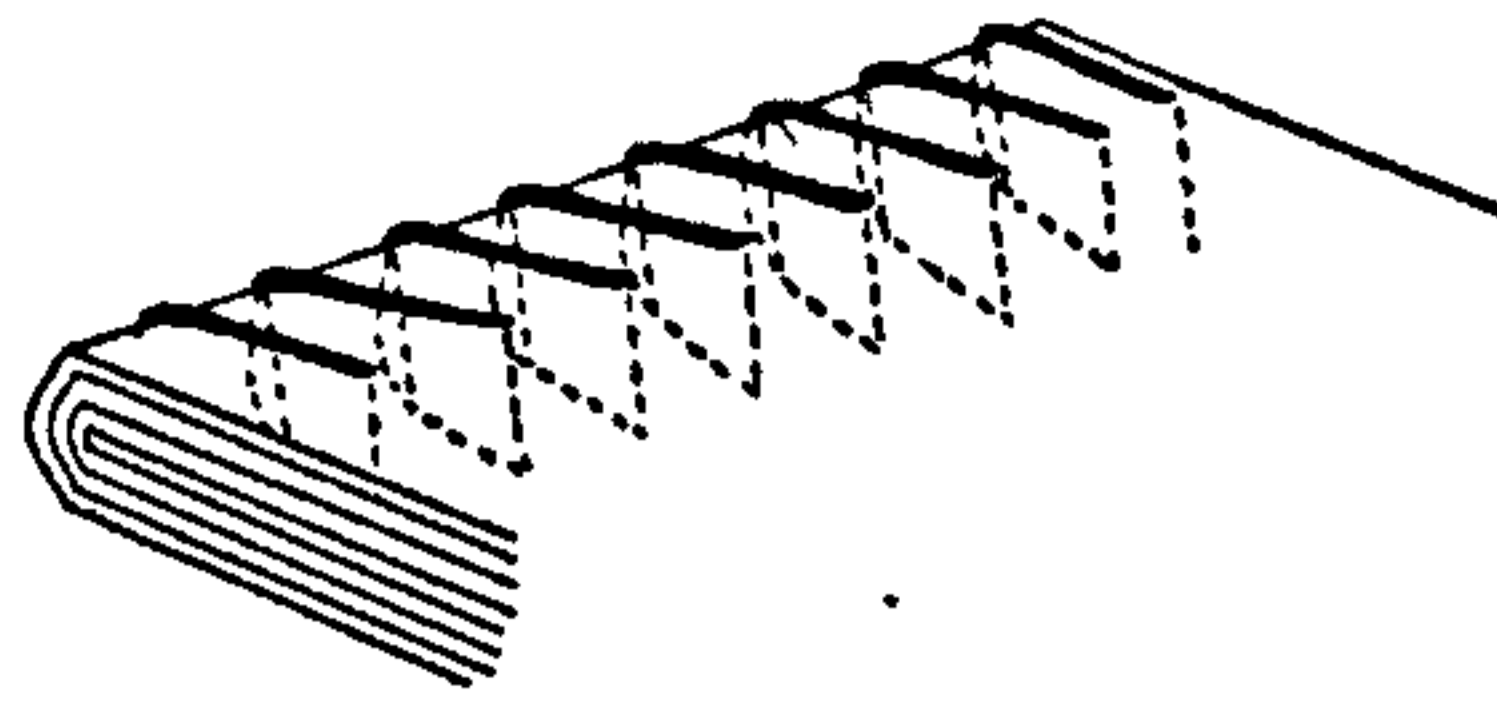

Overcasting, random shape,

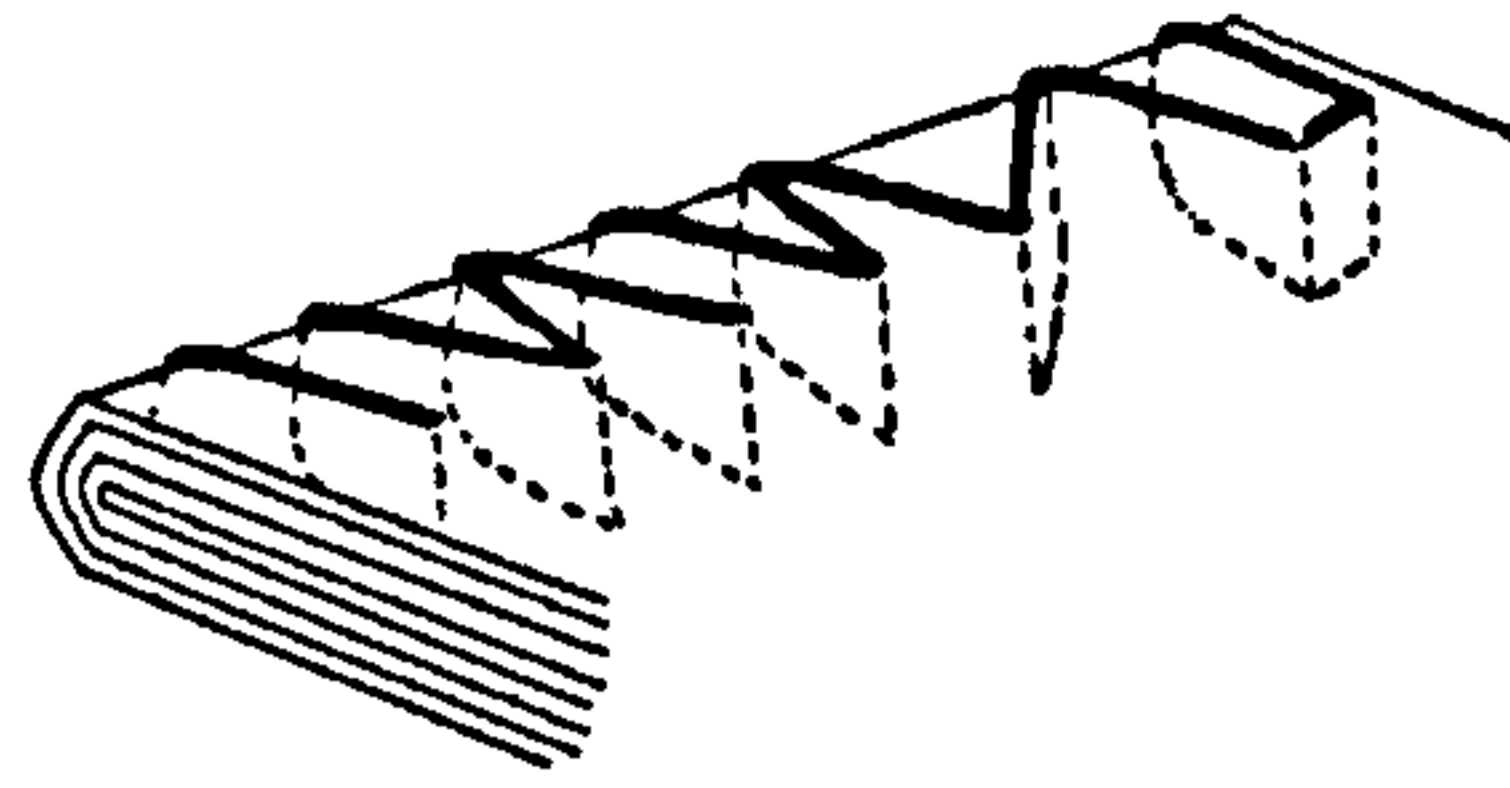

Running Stitch,

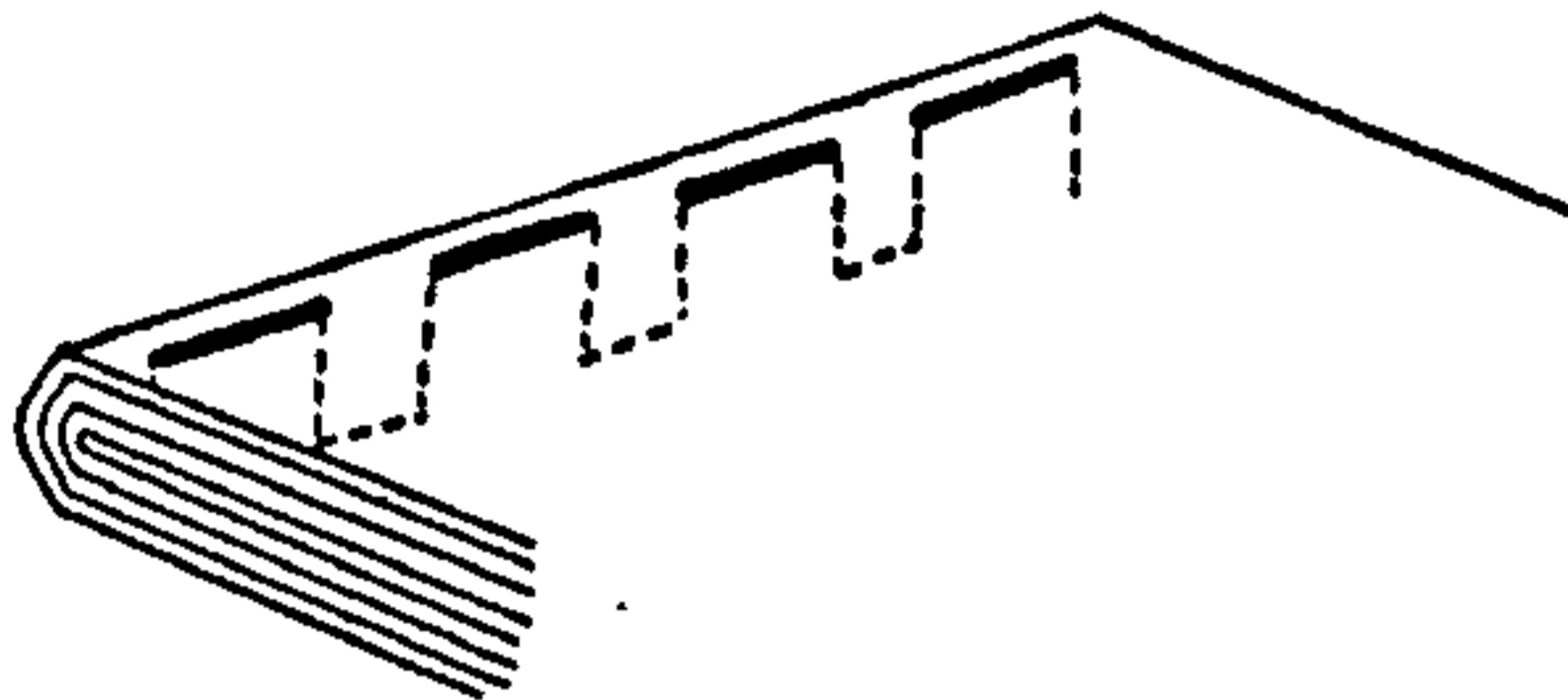

Unused single holes in head and tail of centerfolds

Uncertain.

**Frequency of Preliminary Sewing [Free Text]:** indicates the frequency of preliminary sewing across the text-block but also the extension along the spine of the gatherings or leaves sewn in the case of overcasting or running stitch. For example: 'Occasional, all along the spine-fold', 'In the outermost gatherings, extension varies' etc.

**Sewing Stations Number [Free Text]:** indicates the total number of sewing stations, change-over stations included.

Sewing station is used to describe every point in the spine-fold of a gathering where the sewing thread exits or enters the gathering in order to anchor to the previous gathering (in unsupported sewing) or to be fastened around the sewing supports (for supported sewing structures). Change-over stations are the outermost sewing stations of a text-block through which the sewing proceeds, while the term main sewing station is used to indicate all the other sewing stations between the change-over stations.

**Distances between previous sewing stations [Free Text]:** this field refers to bindings that present unused V shaped cuts, clear evidence that the text-block has probably had at least one previous binding. Usually some of the original accommodation nicks (see below 'Accommodation Nicks' field) are used in the rebinding of a text-block while some remain unused ( see 'Unused V Shaped

Cuts' field in the 'Binding' information group). Since normally there is a regularity in the arrangement of the sewing stations, very often it is not difficult to distinguish the arrangement of sewing stations of the previous sewing, even when partially reused. Therefore this field indicates the distances in millimeters from head to first station (change-over station) and then from station to station until the tail of the text-block. Measurements are recorded in millimeters from station to station. For example the formula '10-20-20-20-13' means that the distance from head to first station is 10mm, from first station to second 20mm etc.

Whenever sewing stations are marked by V shape cuts then measurements represent distances from peak to peak, where by peak is meant the meeting point of the converging cuts in order to form a V.

**Distances between current sewing stations [Free Text]:** indicates the distance in millimeters from head to first station (change-over station) and then from station to station until the tail of the text-block. Measurements are recorded as in the previous field. Ideally measures between stations when added together should be equal with the height of the text-block as this is recorded in the 'Text-block Format' field. Nevertheless this is not always true since there are text-blocks where gatherings may not have exactly the same dimensions. For this reason there may be cases where such coincidence is not found.

**Main Sewing Station Accommodation Nicks [Look-up Field]:** indicates the form of the nicks for the accommodation of the sewing thread in the main sewing stations.

Tiny V shape cuts (width not exceeding two millimeters),  
V shape cuts (width between two and five millimeters),  
Single knife cuts,  
Needle holes,  
Wide knife cuts.

**Change-Over Station Accommodation Nicks [Look-up Field]:** indicates the form and make-up of the nicks for the accommodation of the sewing thread in the change-over stations. V shape cuts are distinguished by single knife cuts by the

fact that they are made by two distinct consecutive converging cuts, while single knife cuts are made by a single cut, perpendicular to the spine-fold axes.

V shape cuts (width between two and five millimeters),  
Tiny V shape cuts (width not exceeding two millimeters),  
Broad V shape cuts (width exceeding five millimeters),  
Single knife cuts,  
Needle holes.

**Kind of Sewing [Look-up Field]:** indicates the kind of sewing:

Supported,  
Unsupported,  
Not known (N. K.)

**Type of Sewing [Look-up Field]:** indicates the type of sewing:

Not visible, (N. V.)  
Not known (N. K.)  
Chain stitch<sup>135</sup>,  
Two steps chain stitch<sup>136</sup>,  
Three steps chain stitch<sup>137</sup>,  
Overcasting<sup>138</sup>,  
Straight sewing<sup>139</sup>,  
Packed straight sewing<sup>140</sup>,

**Sewing Stations Arrangement Pattern [Look-up Field]:** indicates the pattern according to which sewing stations are arranged along the spine of the text-block.

---

<sup>135</sup> See Szirmai 1999, pp. 16-19 described as one-step link stitch (configuration a). See also Petherbridge 1991, pp. 396-397 described as Sewing Stitch Type A or Simple Link Stitch.

<sup>136</sup> Like the previous one, the difference being that the link is made with the corresponding sewing station of the penultimate gathering, which is two gatherings before the currently sewn. See Szirmai, 1999, pp. 16-18 (configuration c), also called the extended link stitch. See also Petherbridge 1991, p. 397 described as Sewing Stitch Type B or Packed Link Stitch.

<sup>137</sup> Like the chain stitch, the difference being that the link is made with the corresponding sewing station of the third gathering before the currently sewn. See Szirmai 1999, pp. 16-18 (configuration d).

<sup>138</sup> See Roberts and Etherington 1982, p. 182.

<sup>139</sup> See Szirmai 1999, p. 148, fig. 8.5b, the difference being that here straight sewing refers to single supports and not to slit-thong supports as in the example that he gives.

<sup>140</sup> See Szirmai 1999, p. 148, fig. 8.5c, the difference being that here Packed straight sewing refers to single supports and not to slit-thong supports as in the example just mentioned.

Three main categories have been identified in the course of the research with many variations for each of them. These are divided according to the relation the outermost panels have with the adjacent ones toward the center of the spine. Therefore the following categories have been identified:

- A. Where all panels in the spine of the text-block are equal or almost equal.
- B. Where the outermost panels in the spine are smaller than the adjacent ones.
- C. Where the outermost panels are larger than the adjacent ones.
- D. Where no constant and clear relation between the different panels can be identified.

The graphic representation can sometimes provide an immediate identification but can also often disguise the eye. For this reason the classification is based on the measures from sewing stations to sewing station and the magnitude relations between them. The drawings below are only indicative of these magnitude relations between the different panels. The different colours indicate panels with the same or similar dimensions (with a divergence of a few millimeters) dimensions.

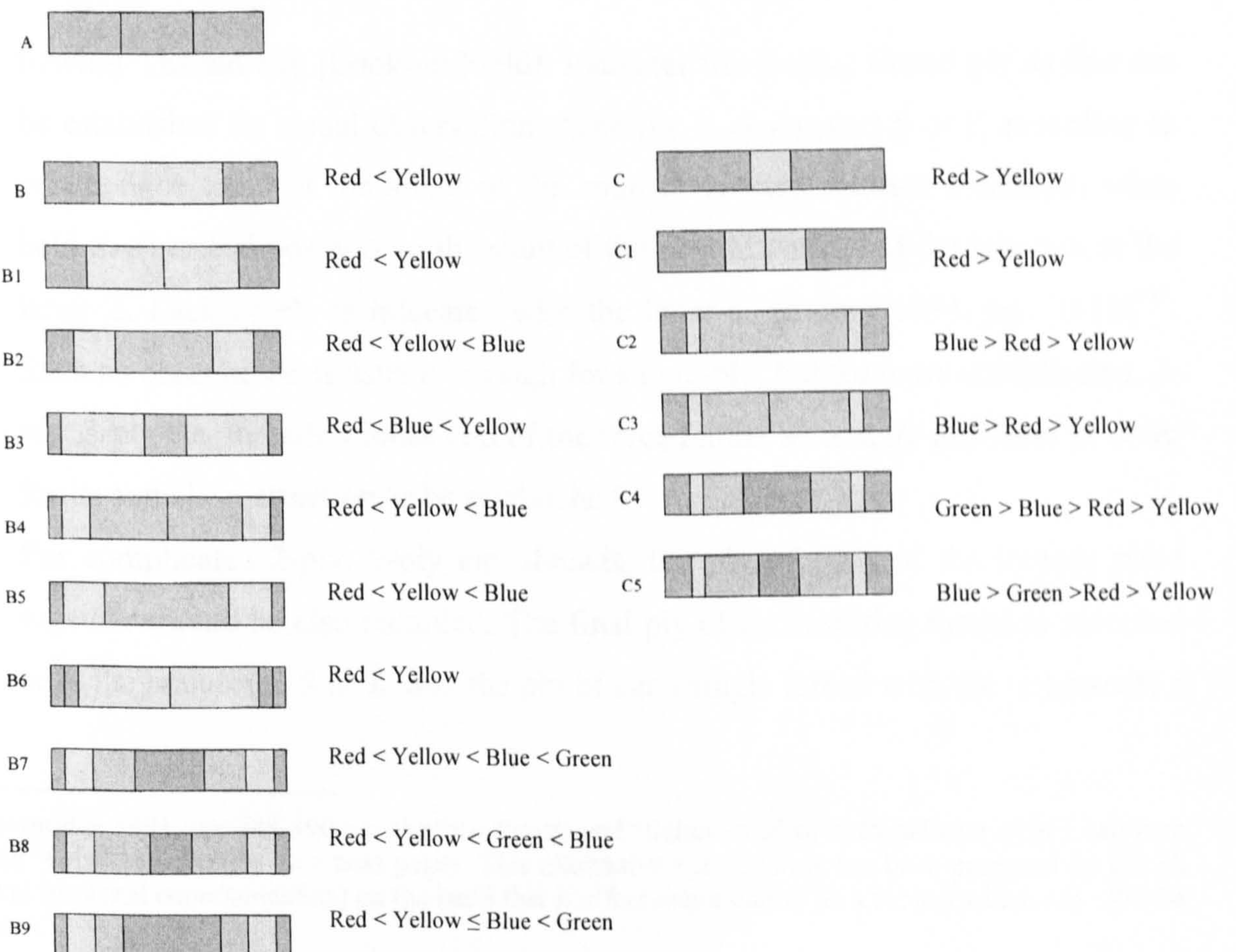

**Sewing Thread [Look-up Field]:** indicates the kind of the sewing thread used. Identification is based on visual observation only, no analytical methods have been used for their identification:

Cotton,  
Silk,  
Linen,  
Hemp,  
Not known (N. K.)

**Sewing Thread Thickness [Look-up Field]::** indicates the relative thickness of the sewing thread based on visual observation.

Extra thin,  
Thin,  
Medium,  
Thick,  
Extra thick

**Sewing Thread Ply [Look-up Field]:** indicates the sewing thread ply as this can be established by visual observation. "The ply is designated S or Z according to whether the trend of the spiral of the spun or twisted element conforms, when held in a vertical position, to the slant of the central portion of the letters S or the letter Z. Lack of ply is indicated with the letter I" (Emery 1994, pp. 10-12)<sup>141</sup>. Such an observation is usually enough for single-ply, but for more complicated, 2-ply, 3-ply etc. threads a loose end of the thread must be usually available in order for its actual construction to be established.

For complicated 2-ply, 3-ply etc. threads, the ply of each of the threads plied together should be also recorded. The final ply of the resulting thread is recorded with the majuscule S or Z and the ply of each single thread with the minuscule s

---

<sup>141</sup> Petherbridge 1991, pp. 388-390 use the term 'twist' and 'tightness of twist' to indicate what I call here 'ply' and 'twist' respectively (see next page). This alternative use of terms has been proposed by Dr. N. Pickwood (personal communication) on the basis that it offers major clarity on a subject which can often be confusing.

or z. For example the formula 2 2z S means that the thread is S-ply consisting of two threads each of them consisting of two filaments previously z-ply together.

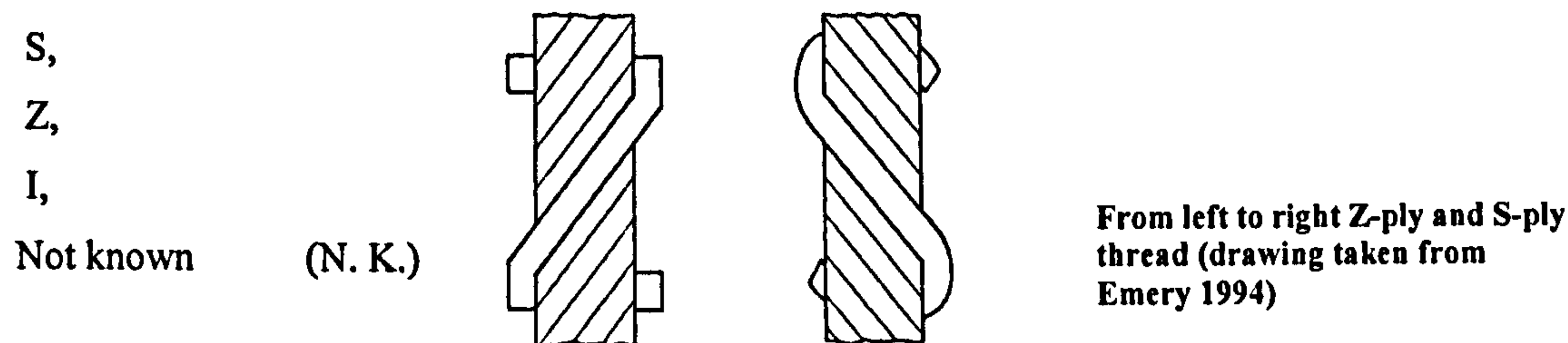

For the needs of the present research and for reasons of time and accessibility to such features the final twist of threads is usually recorded, except those cases where a loose end of the thread was readily available.

**Sewing Thread Twist [Look-up Field]:** indicates the tightness of the plied thread and refers to the angle that the slant of the spin makes with the vertical axis of the yarn. This statement is also based on visual observation and could not be established for all sewing threads surveyed. Waxed sewing threads are particularly problematic in recording such feature since waxing of the thread often alters the tightness of the plied thread. Endband silk threads are also problematic.

- Tight (angle between 25° and 45°),
- Medium (angle between 10° and 25°),
- Loose (angle up to 10°),
- Uncertain.

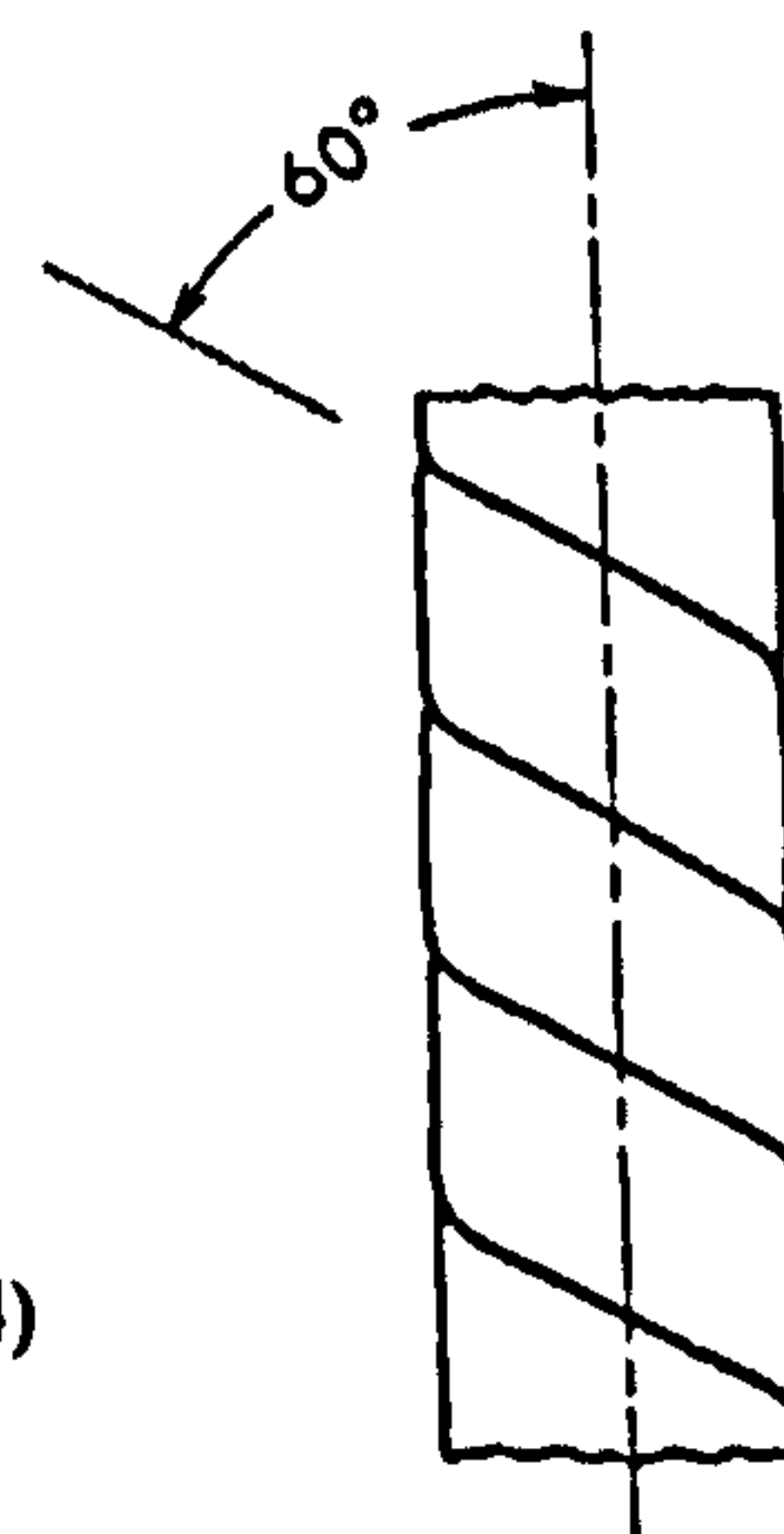

The angle of twist (drawing taken from Emery 1994)

**Sewing Supports Number [Free Text]:** refers to the number of the sewing supports on which the text-block is sewn, but also indicates if they are single or double. Usually the number of supports will be smaller by two to the number of



sewing stations since change-over stations are normally not supported, though exceptions have been found.

**Sewing Supports Material [Look-up Field]:** indicates the material of which the sewing supports are made.

Cord,  
Leather thong flat,  
Leather thong twisted,  
Parchment flat,  
Parchment twisted,  
Combination.

**Sewing Supports Type [Look-up Field]:** indicates if the supports are raised or recessed in the spine of the text-block .

Raised,  
Recessed.

**Sewing Supports Thickness [Look-up Field]:** indicates the relative thickness of the supports.

Thin,  
Normal,  
Thick,  
Extra thick.

**Notes on the Sewing [Free Text]:** refers to any notes on the sewing that should be recorded though the present fields of the database do not allow for their recording. These notes could lead to modifications-additions in the database or remain as an individual note for the corresponding binding to which they refer.

**BOARD INFORMATION** includes the following fields:

**Visible?** [Look-up Filed]: indicates the visual access one has to the various parts and technical features of the boards construction:

Yes,

No,

Partly enough,

Partly not enough,

Missing.

**Board Material** [Look-up Field]: indicates the material used for the construction of the boards, based on visual observation only. The distinction between soft and hard wood is made only on the basis of visual observation and on the principle of the compactness of the grain: soft wood has sparse grain, hard wood has dense grain.

Softwood,

Hardwood,

Chestnut,

Pasteboard,

Laminated board, leather and Ms waste

Pasteboard paper Ms,

Pasteboard Western paper Ms,

Pasteboard Eastern paper Ms,

Not known (N. K.)

**Board Thickness** [Free Text]: indicates the average thickness of the boards in millimeters.

**Dimensions** [Look-up Filed]: indicates the dimensions of the boards with respect to the text-block dimensions.

Flush,

Undersize,

Projecting (Boards that are bigger than the text-block, presenting more or less marked squares around the edges of the text-block),

N. K.

**Wood Grain Direction [Look-up Filed]:** indicates the direction of the grain of wooden board in respect to the spine of the book:

Vertical (parallel to the spine of the text-block),

Horizontal (vertical to the spine of the text-block),

Other,

N. K.

**Board Edge Groove [Yes/No]:** Yes if there is a groove, either continuous or interrupted around the boards external edges.

**Type of Board Groove [Look-up Filed]:** indicates the type of groove of the boards edges when there is one.

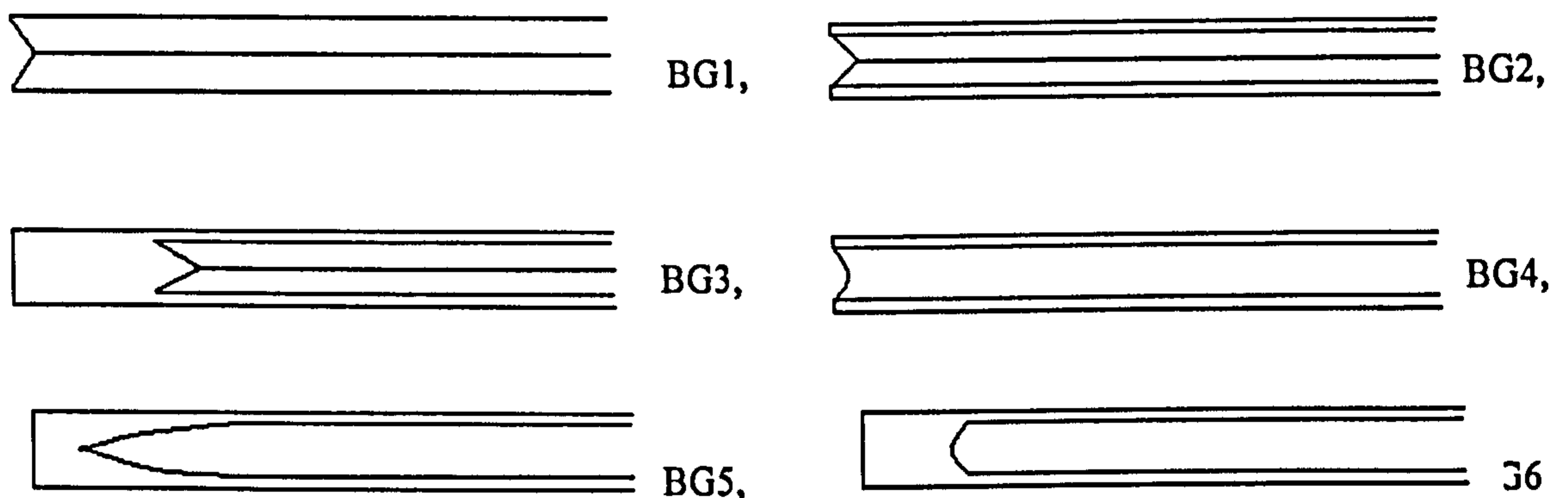

**Beveled edges [Look-up Field]:** Yes if there are squares in the books boards and if their edges are beveled toward the inside or outside.

No,

Yes,

Yes, toward the inside,

Yes, toward the outside all around,

Yes, toward the outside interrupted (Where boards are not beveled all around but only locally, normally in between the board corners.),

Yes, toward the outside in head and tail,

Yes, toward the outside in fore edge.

**Type of beveled edges** [Look-up Filed]: indicates the type of the beveled edges. The second type, 'BE2' consists of wooden or cane wedges fixed with nails or pasted on the board edges before covering.

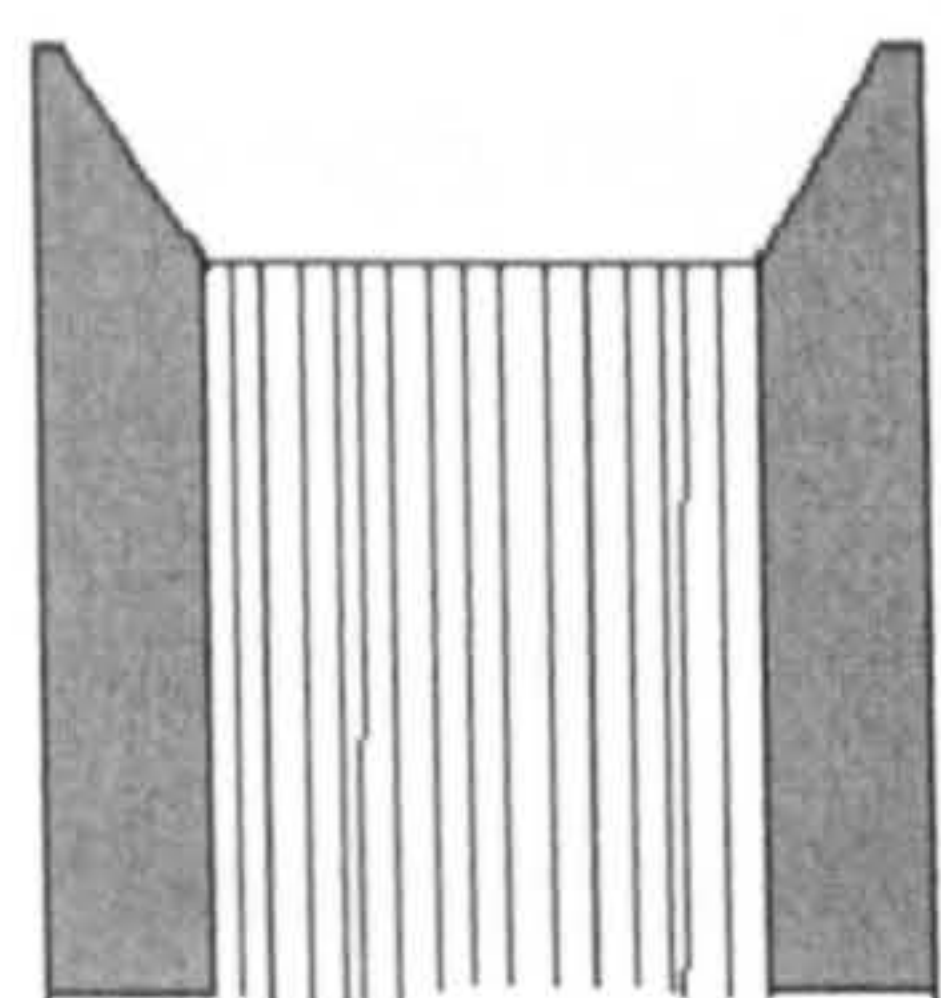

BE1

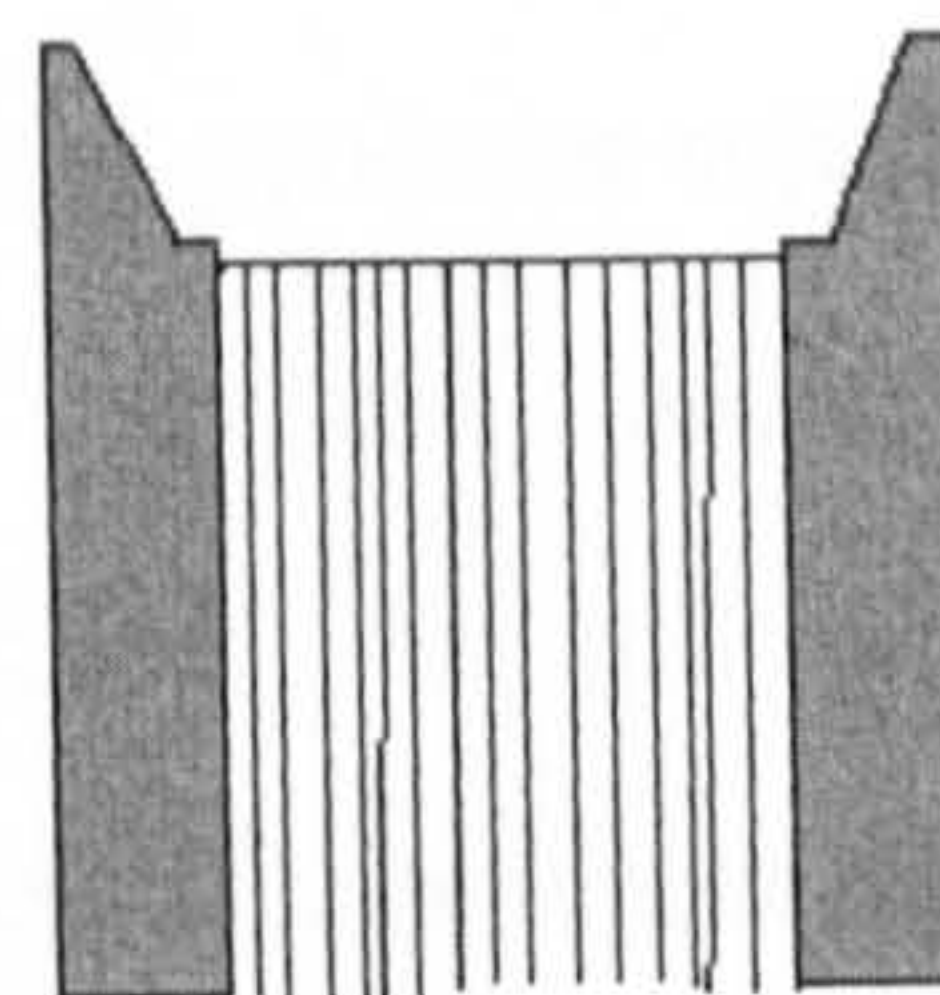

BE2

**Width of Squares** [Free Text]: indicates the average width of the boards squares in millimeters. When not consistent all around, 'varies' is recorded.

**Spine edge Treatment** [Look-up Filed]: indicates the form of the spine edge of the boards. Bold line indicates the outside of the board

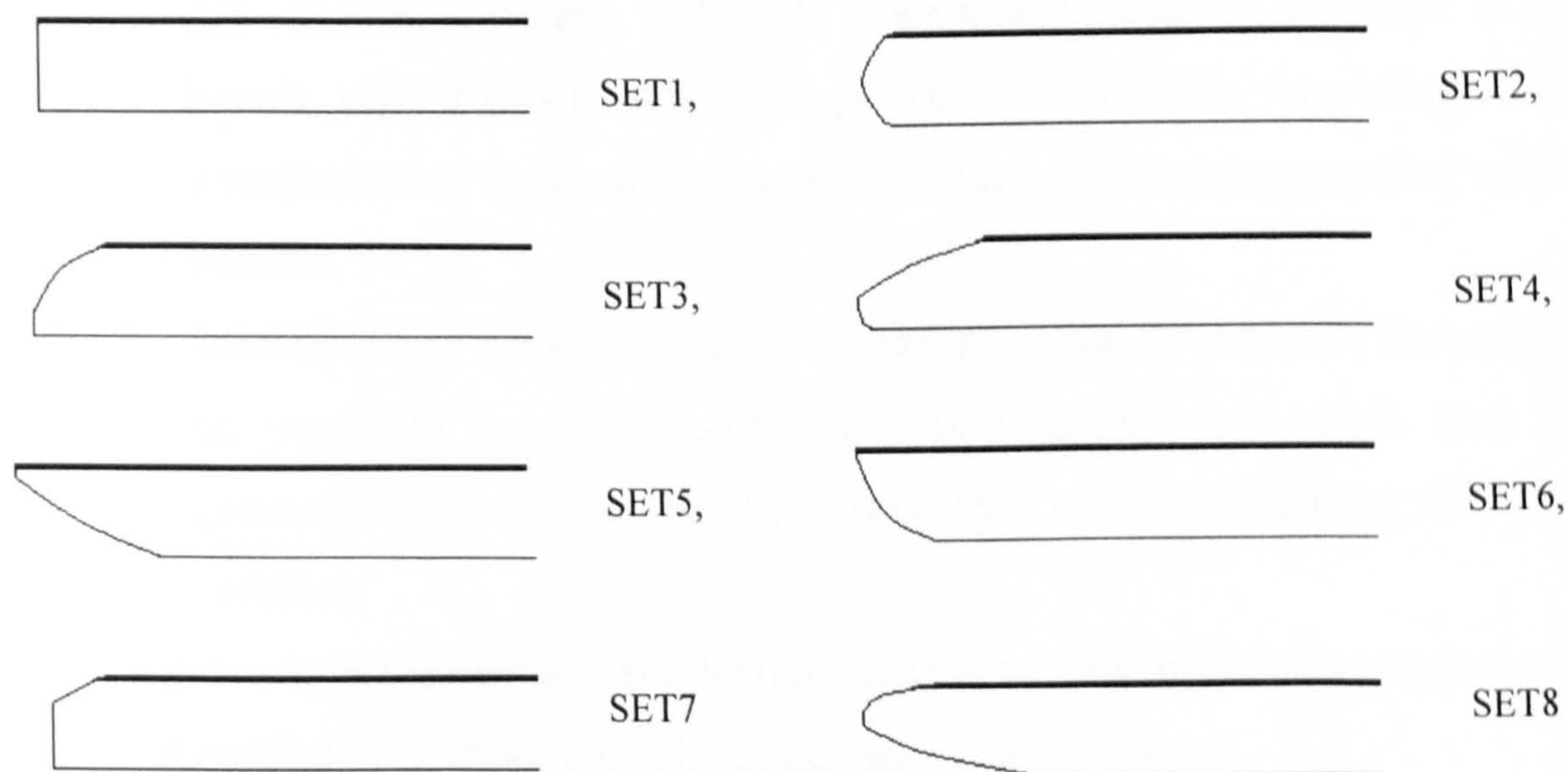

**Marks of Tools** [Free Text]: indicates any score marks left on the boards from the tools used to shape or cut them, such as sawing marks, cleaving marks, etc.

**Attachment System** [Look-up Field]: indicates the system by means of which the boards are attached to the text-block. Endband cores which may be laced through

the boards do contribute to the attachment between text-block and boards but they are considered separately in the endband section. In the same way that Greek style endbands are not considered here but separately though they definitely contribute to the attachment. Three categories of attachment systems are considered:

1. Attachment of the boards to an unsupported sewn text-block made either through bridling<sup>142</sup> or as part of the sewing process which starts from the boards rather than the first gathering of the text-block<sup>143</sup>. To be able to distinguish one from the other full access to all detail is essential, therefore, normally it is very difficult to tell if one technique has been used or the other. Attachment systems of this type are generally designated as 'I Uns' followed by a number specifying the exact variation in which further variations can be found, normally dealing with the passages of the thread through the boards, indicated with a letter: 'a', 'b', 'c', etc.
2. Attachment of the boards to an unsupported sewn text-block made through the extension of the spine lining and the pastedowns. According to the side of the board where the spine lining is pasted there are two variations of this attachment system: 'II Uns/A' when this is pasted on the inside of the boards, and 'II Uns/B' when it is pasted on the outside. According to the arrangement of the pastedowns there are further variations specified with a number.
3. Attachment of boards in supported sewing made through the lacing onto the boards of the sewing supports. Attachment systems of this type are generally designated as 'Sup' followed by a number specifying the exact variation

All drawings below represent the inner face of boards, while cross sections are cut parallel to the head and tail edges, inner face facing up.

---

<sup>142</sup> The term is used to indicate the use of a separate thread in order to attach an already sewn text-block to the wooden boards by looping it through the boards and the sewing. For an explanation of this as well as graphic representations see Federici and Houlis 1988 pp. 23-27 and figures. 16-17. See also Szirmai 1999, pp. 69-73.

<sup>143</sup> See Federici and Houlis 1988 pp. 23-27 and figures 15. See also the Ivron Scriptorium bindings in section 3.1.2.

# I Uns/1 Attachment Systems

I Uns/1

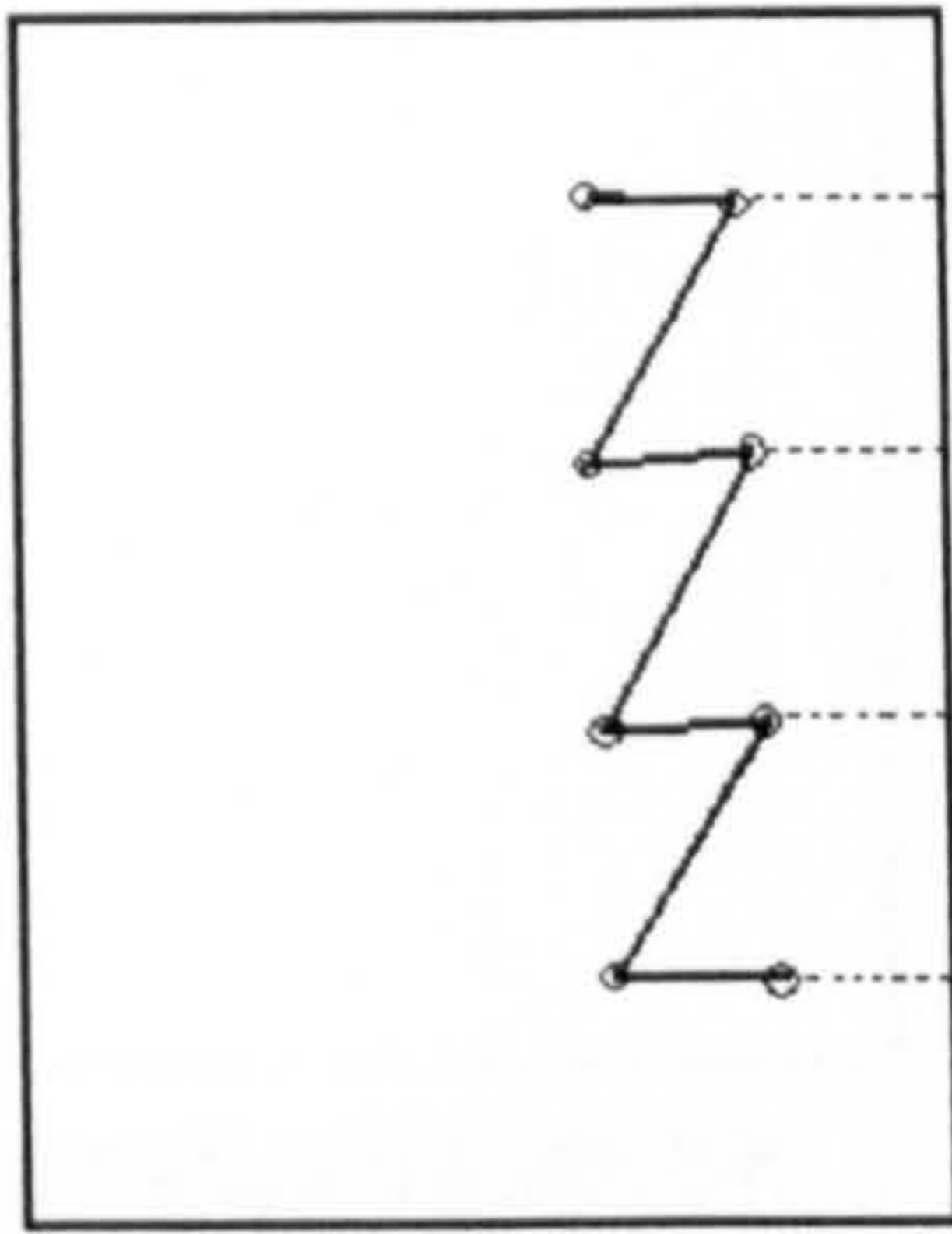

- A
- B
- C
- D

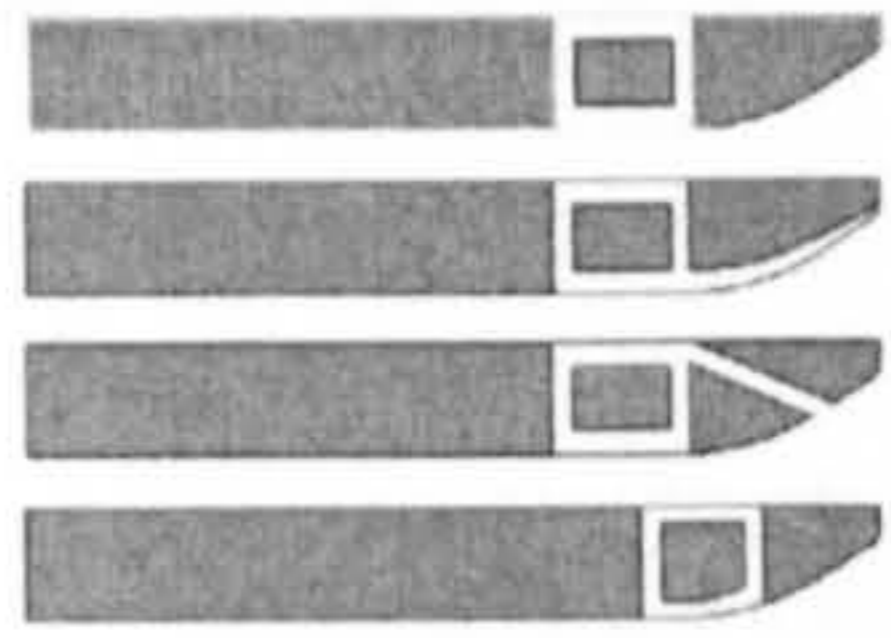

I Uns/2

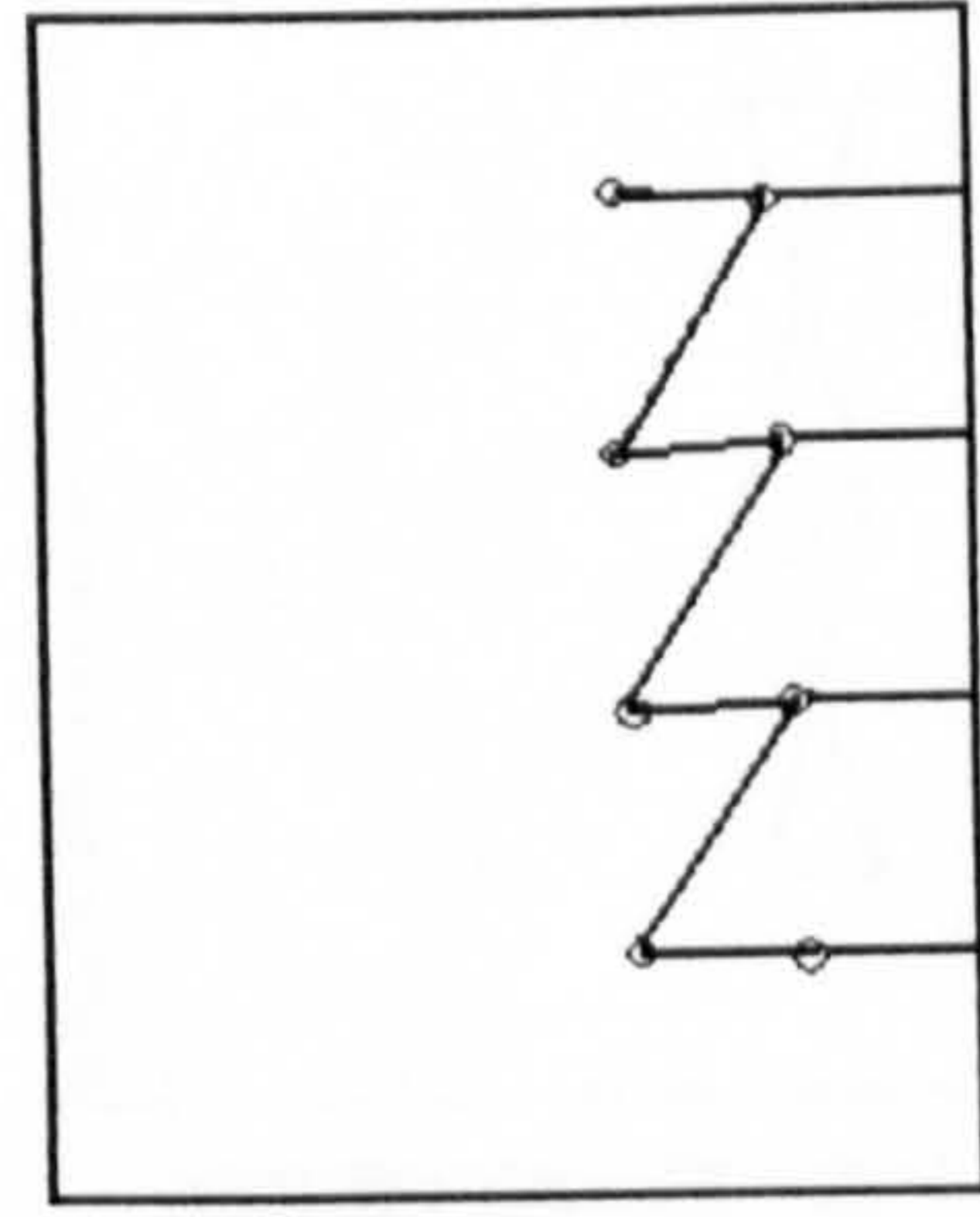

- A
- B
- C

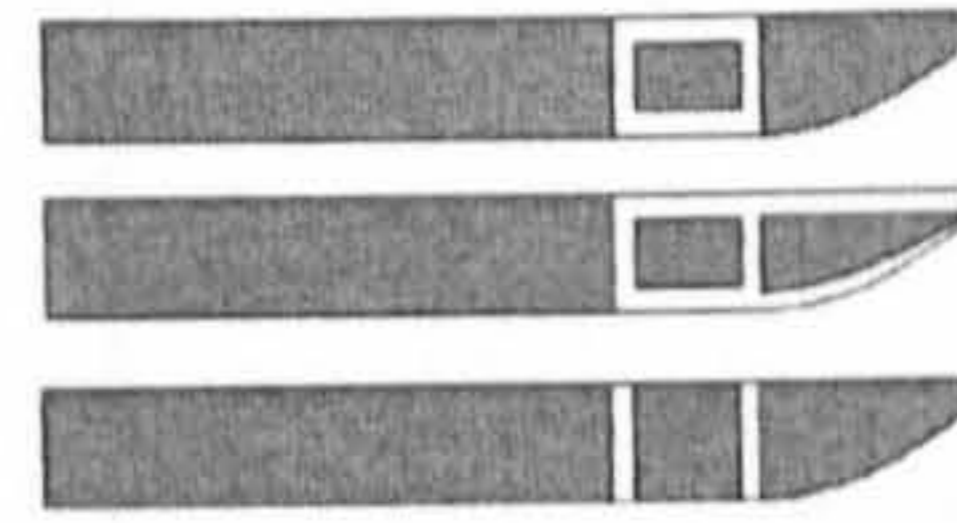

I Uns/3

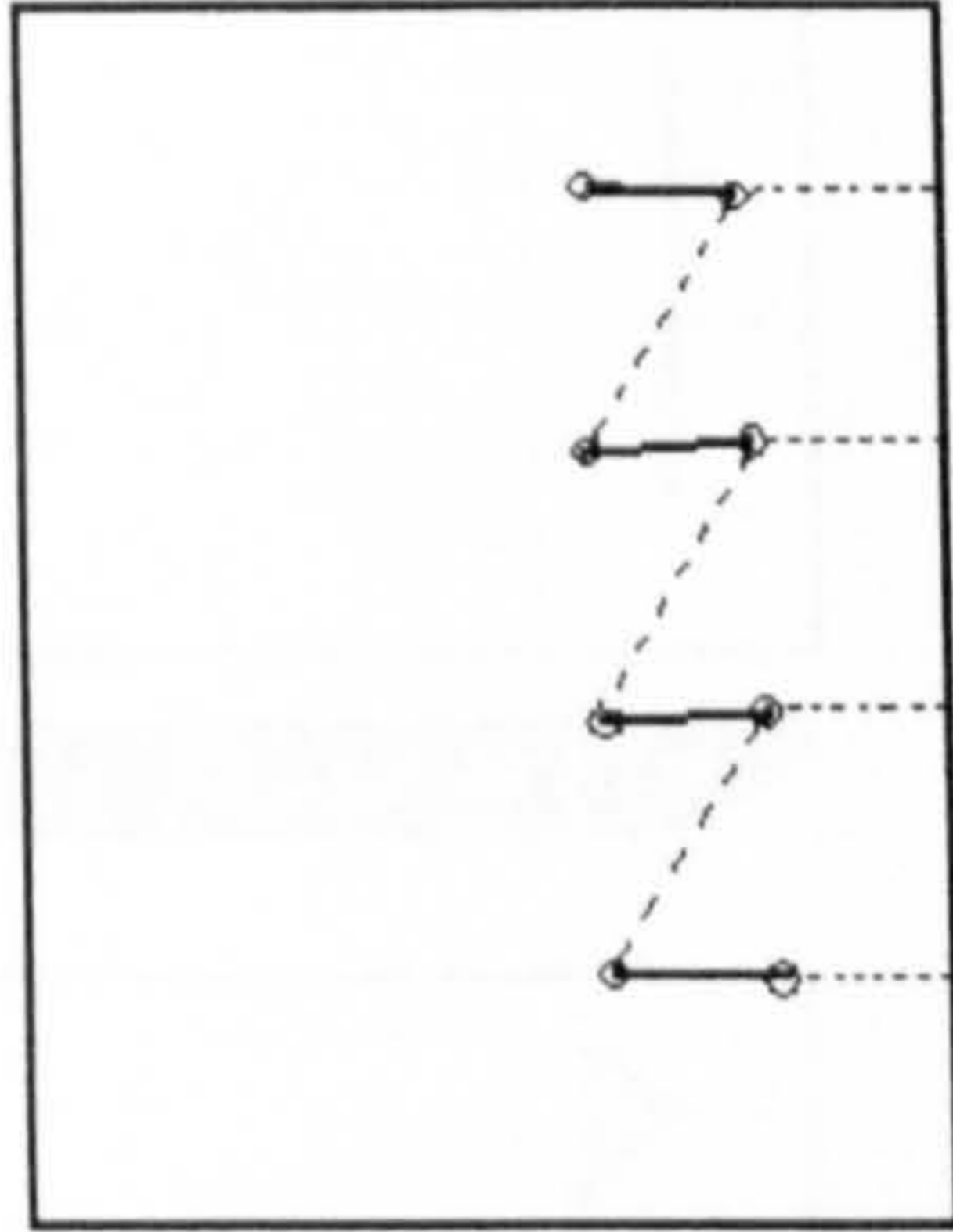

- A
- B
- C
- D
- E

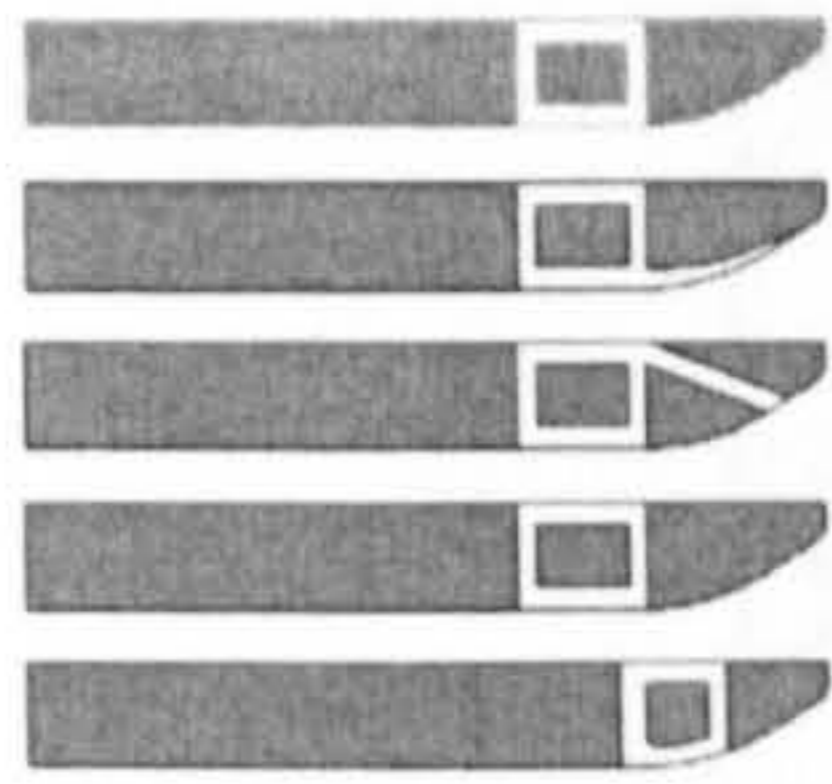

I Uns/4

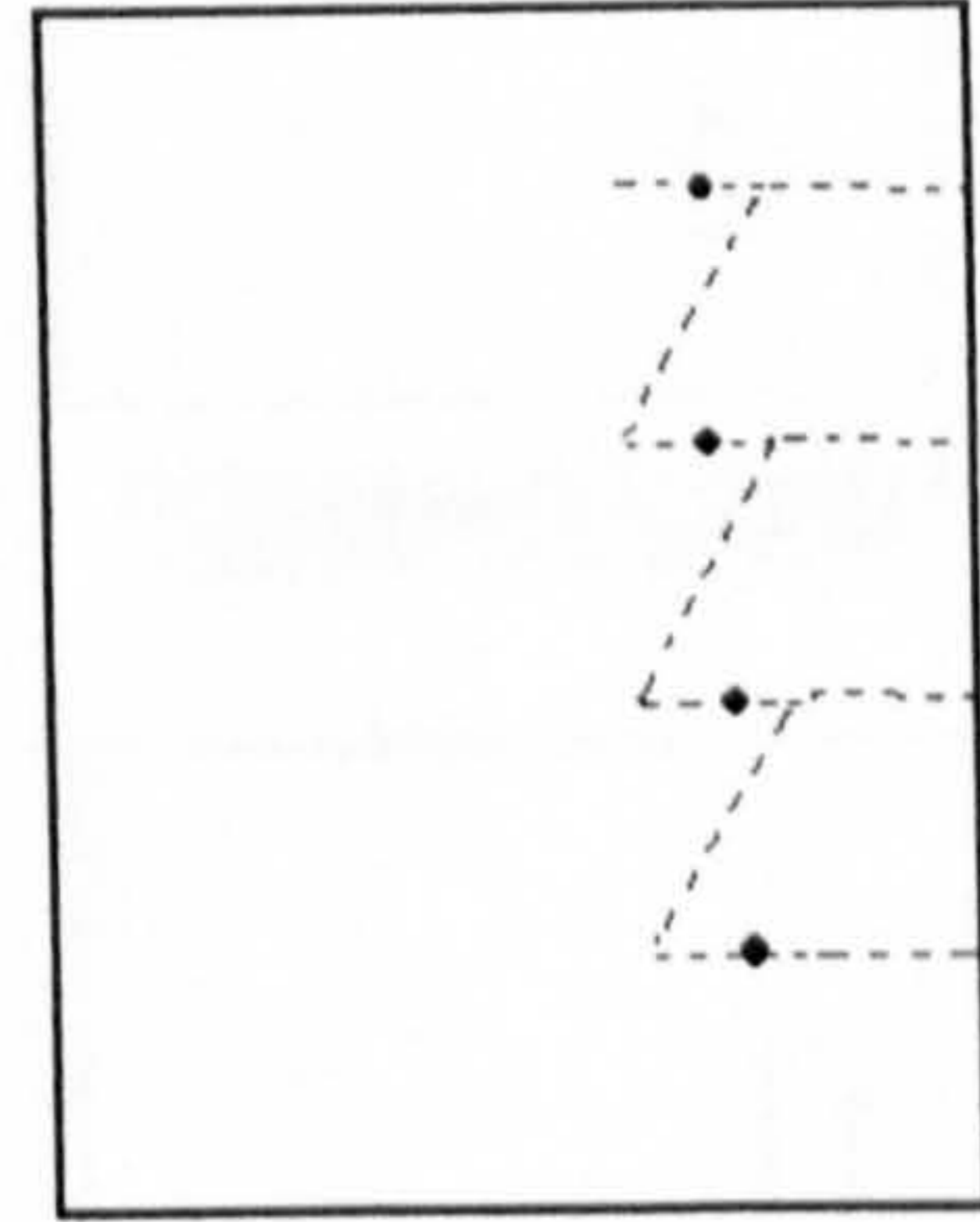

- A
- B
- C

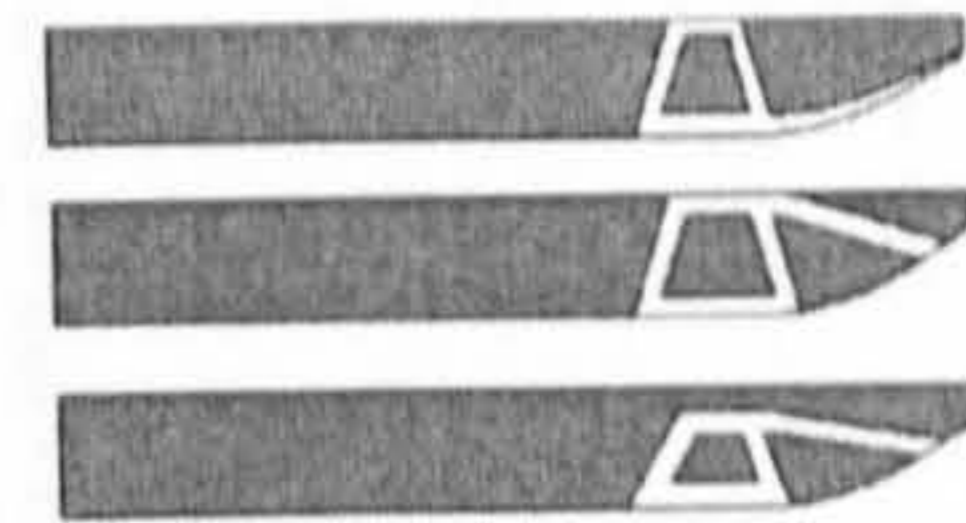

I Uns/5

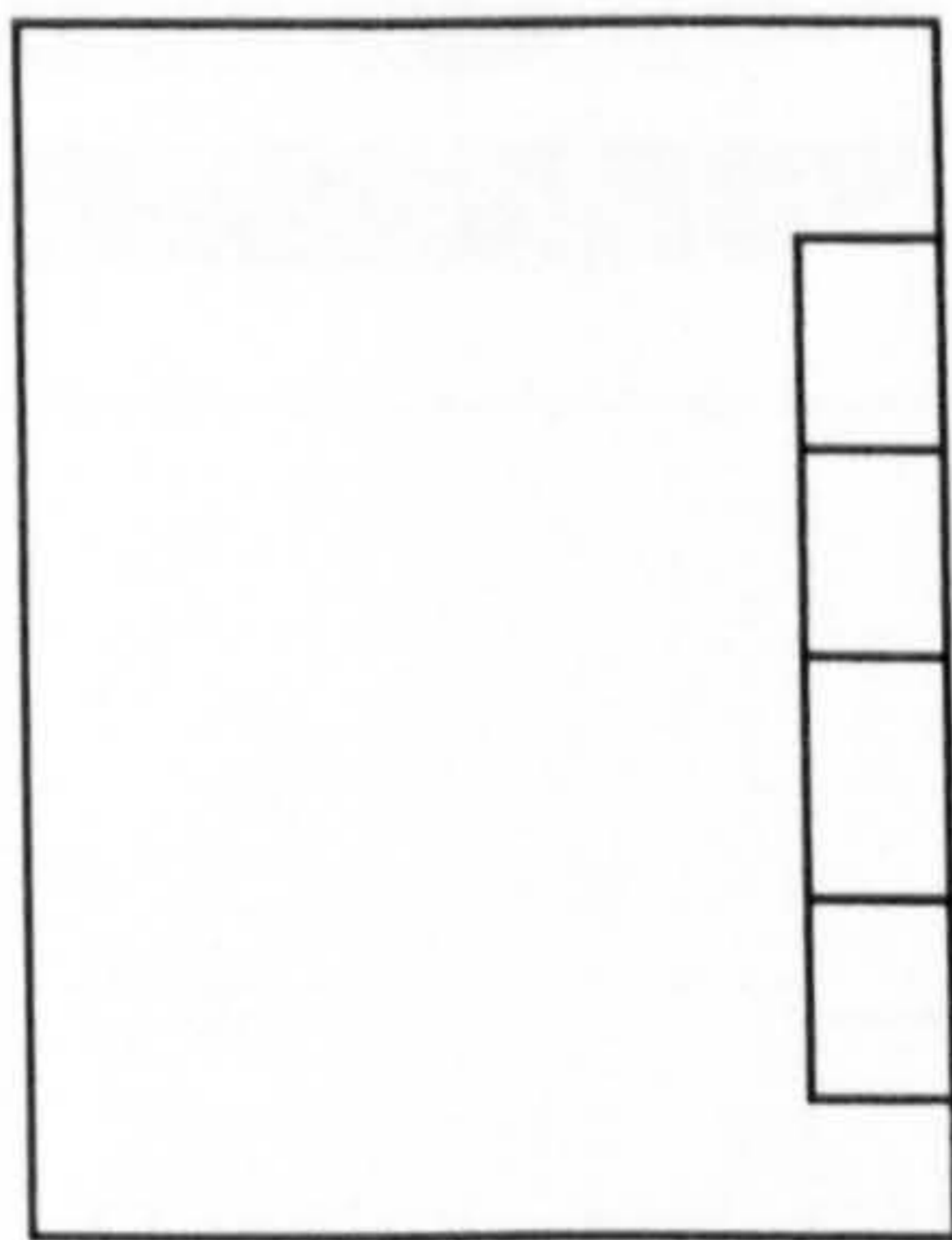

- A
- B

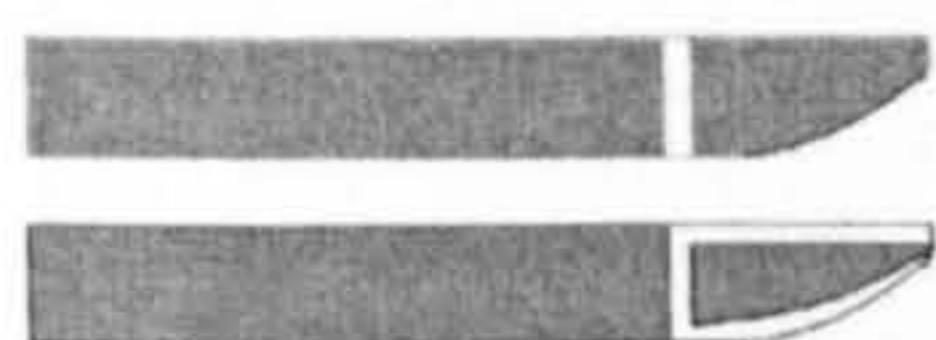

I Uns/6

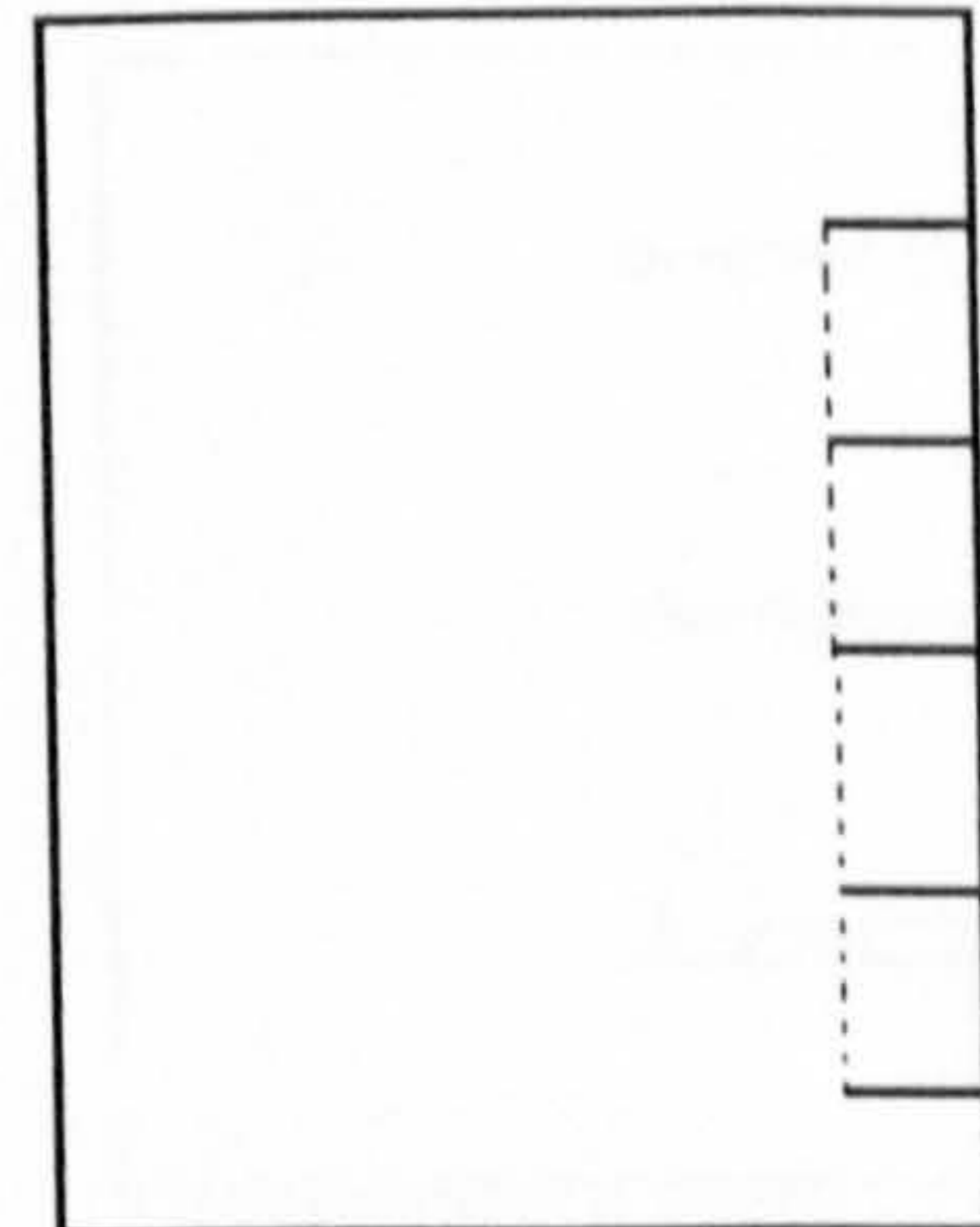

- A
- B



I Uns/7

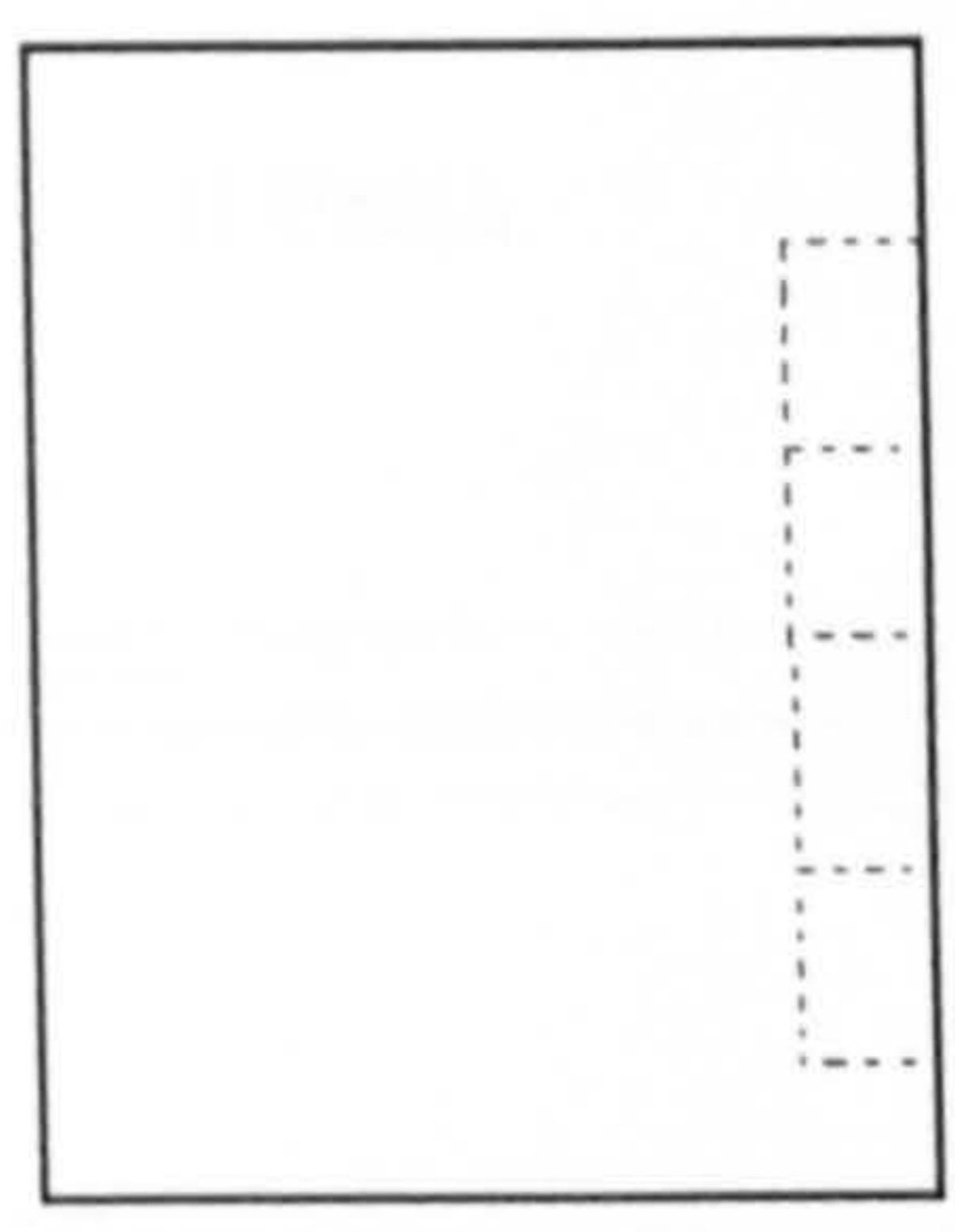

A  
B

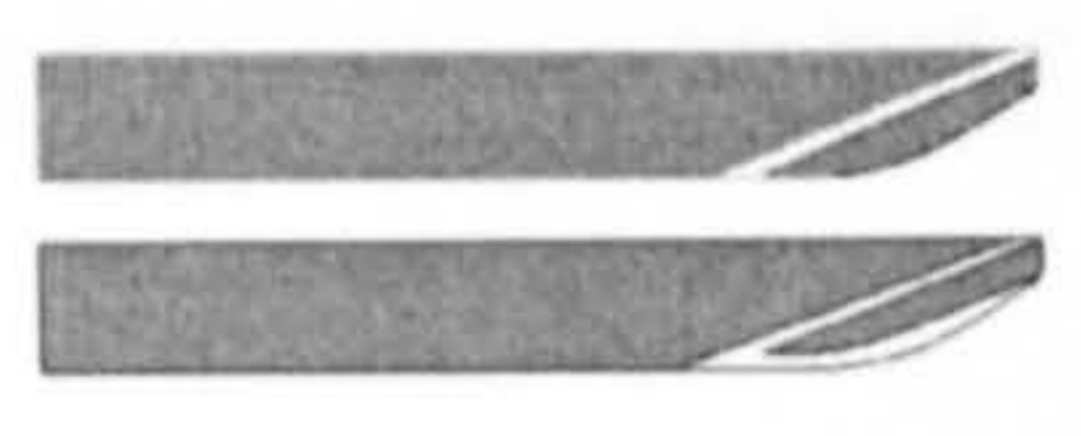

I Uns/8

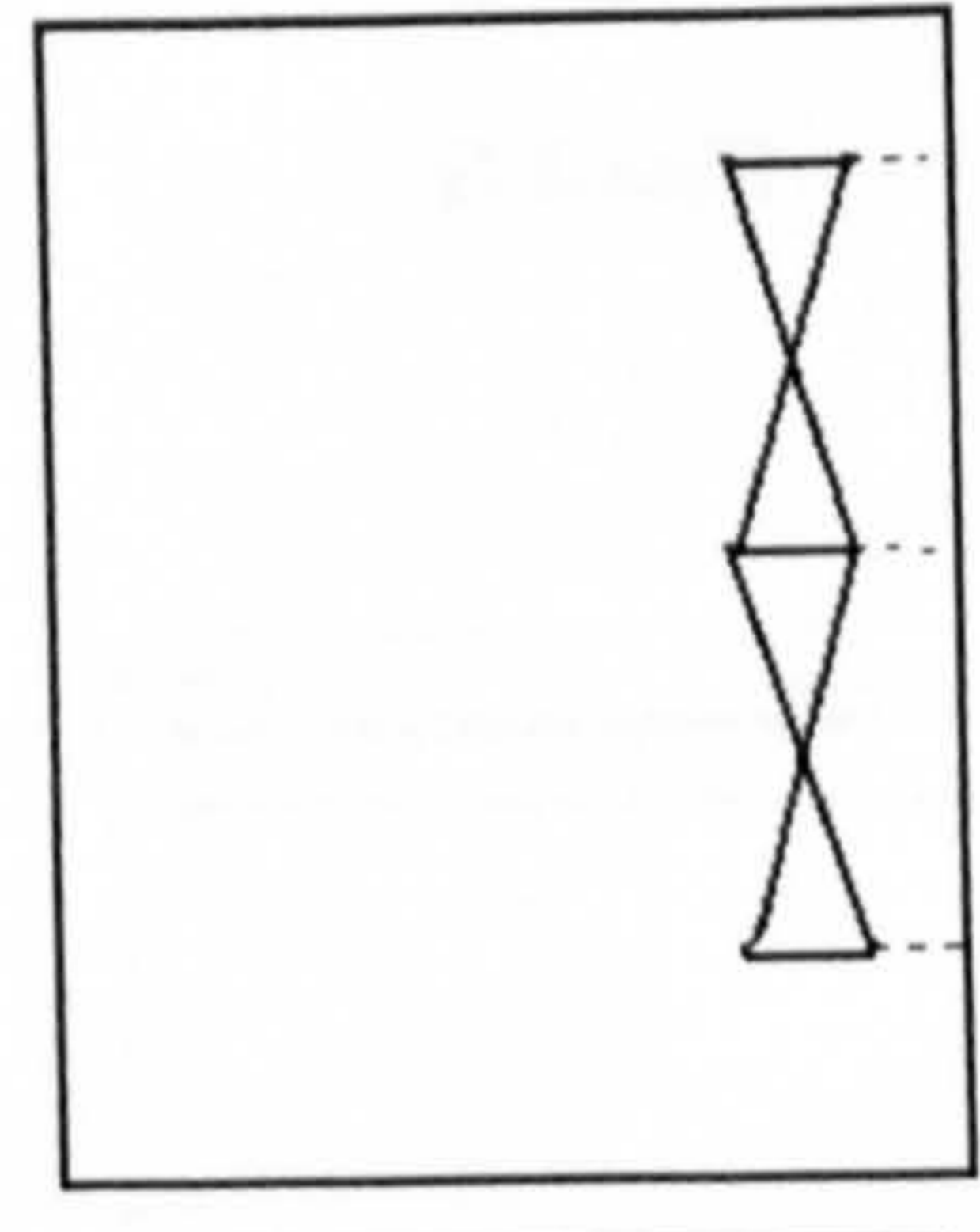

A



I Uns/9

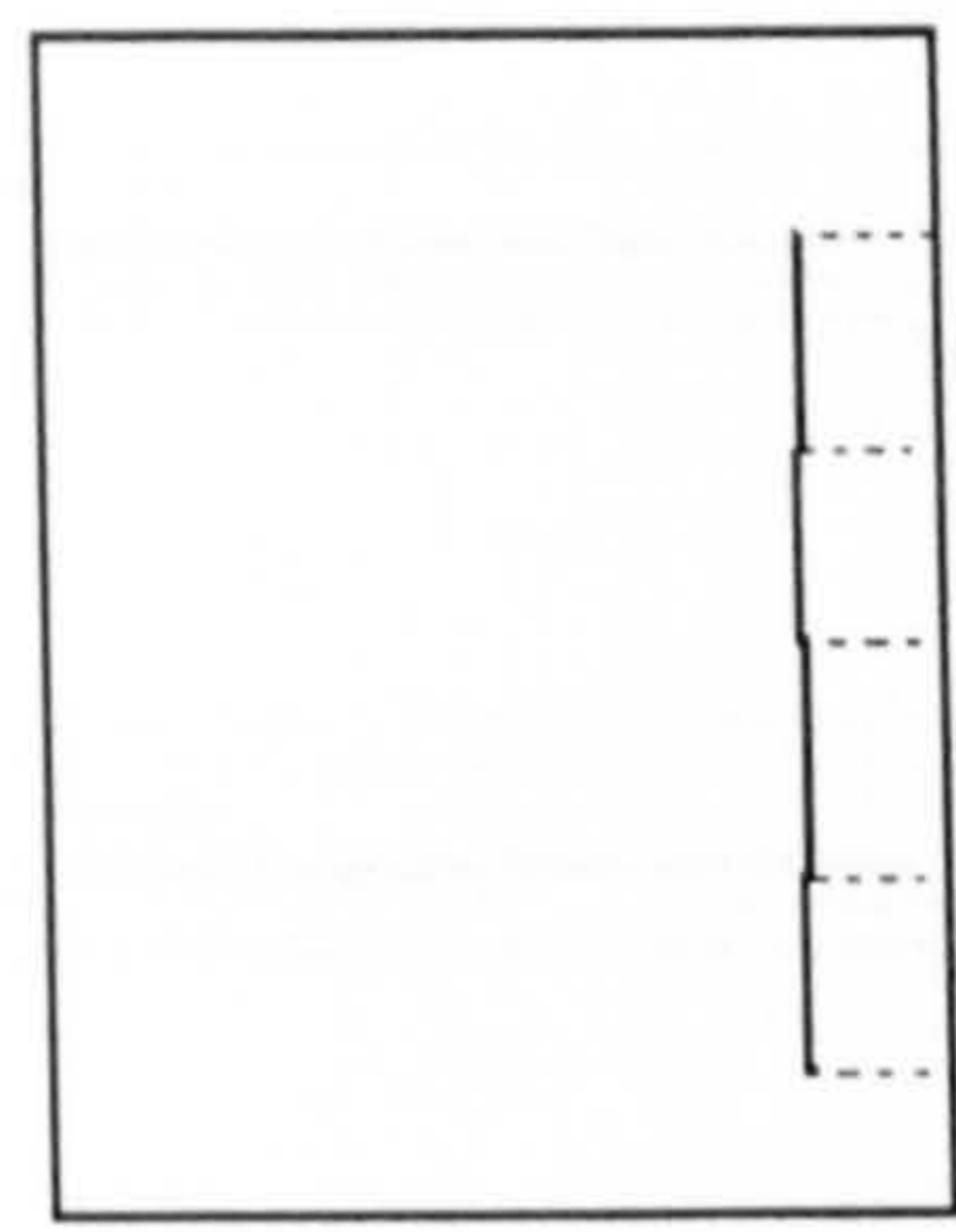

A



I Uns/10

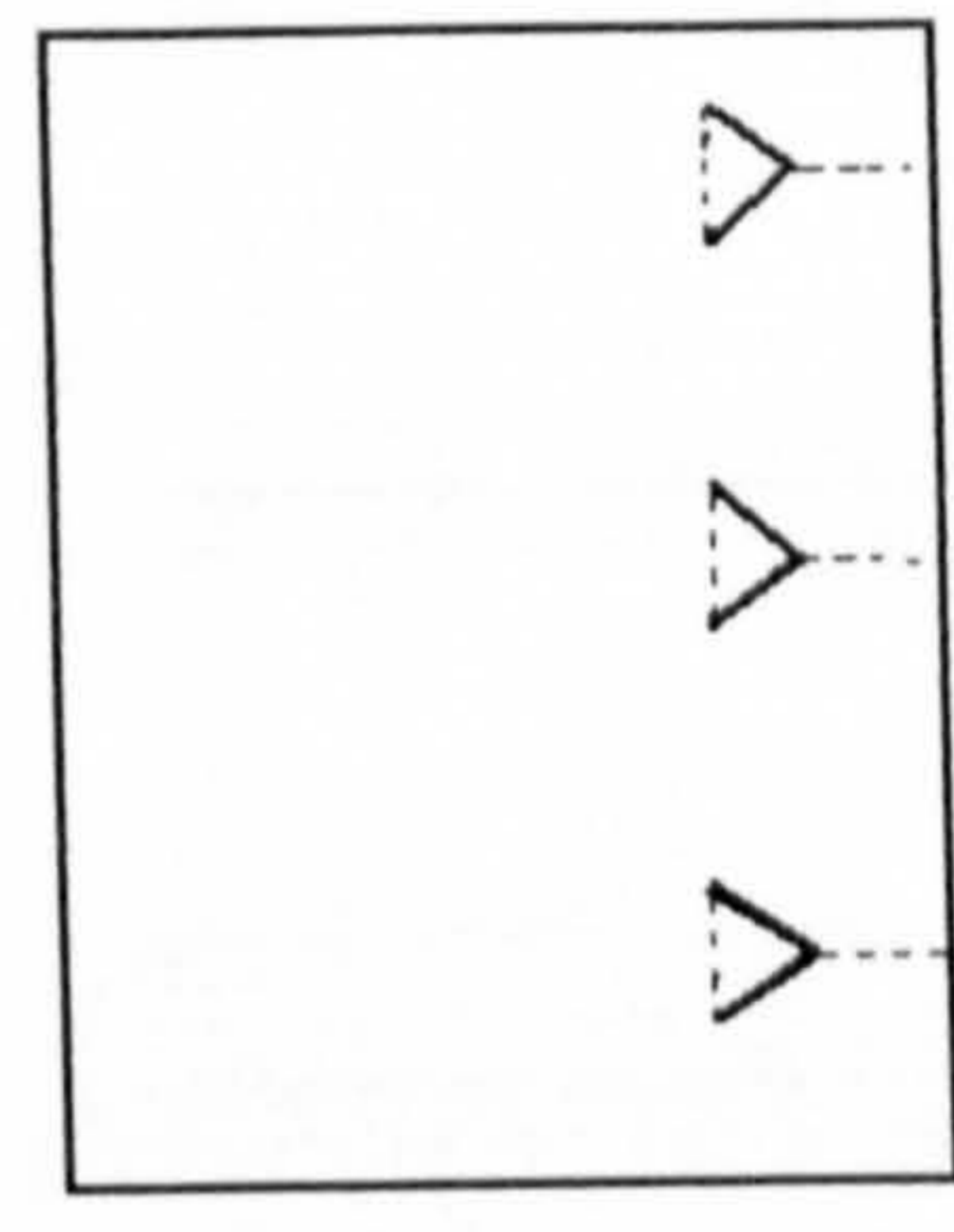

A



I Uns/11

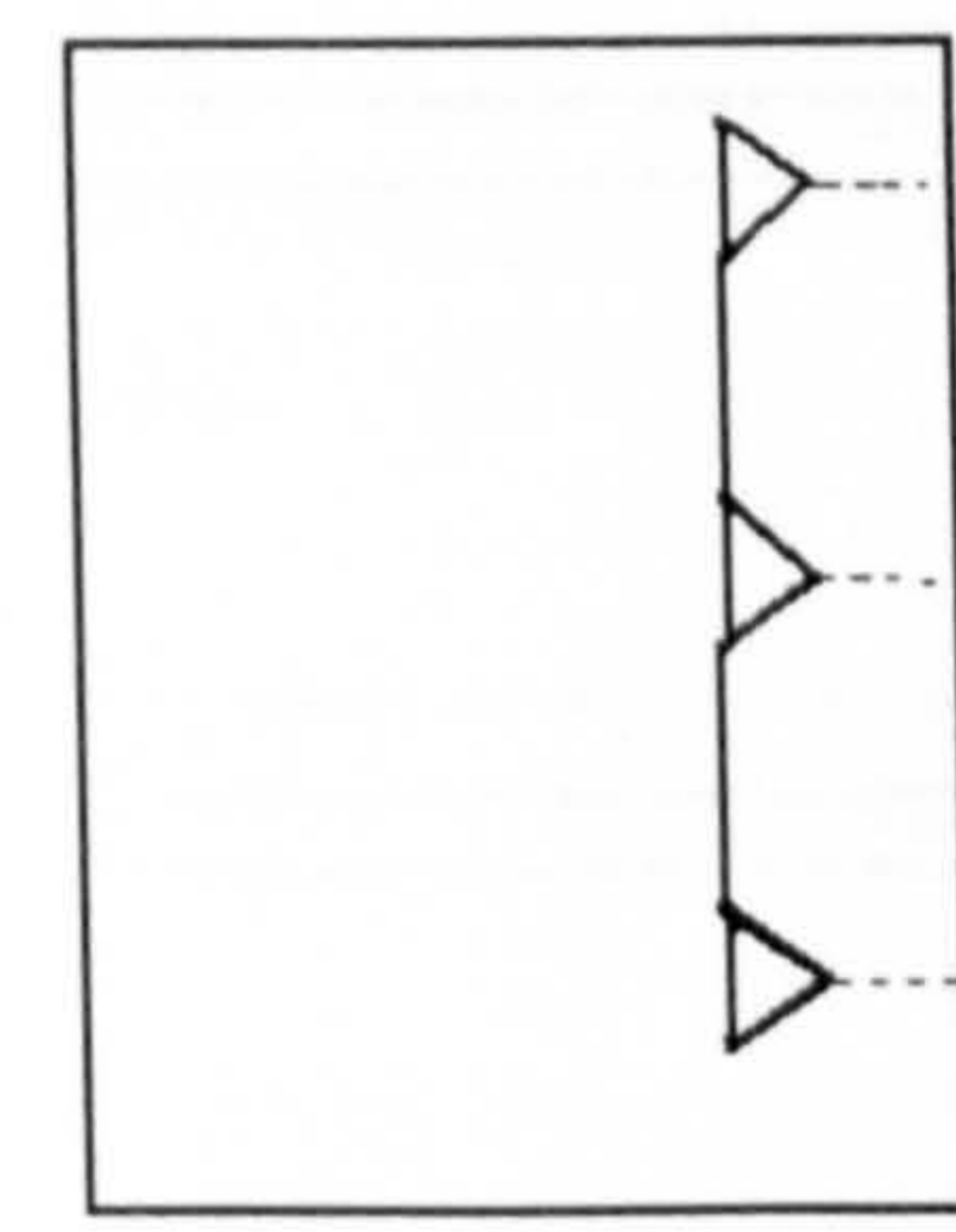

A  
B

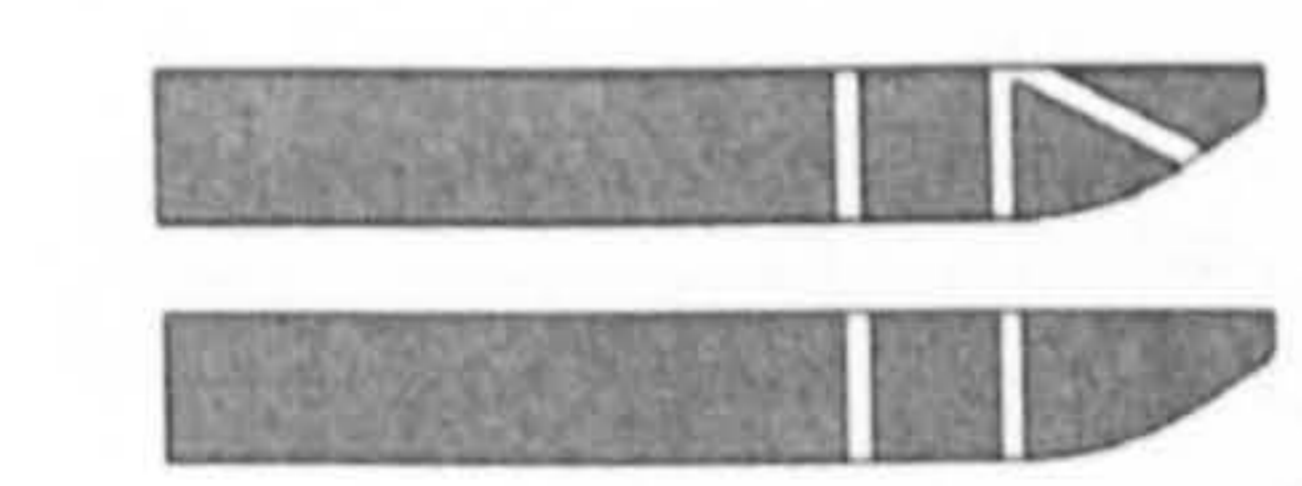

I Uns/12

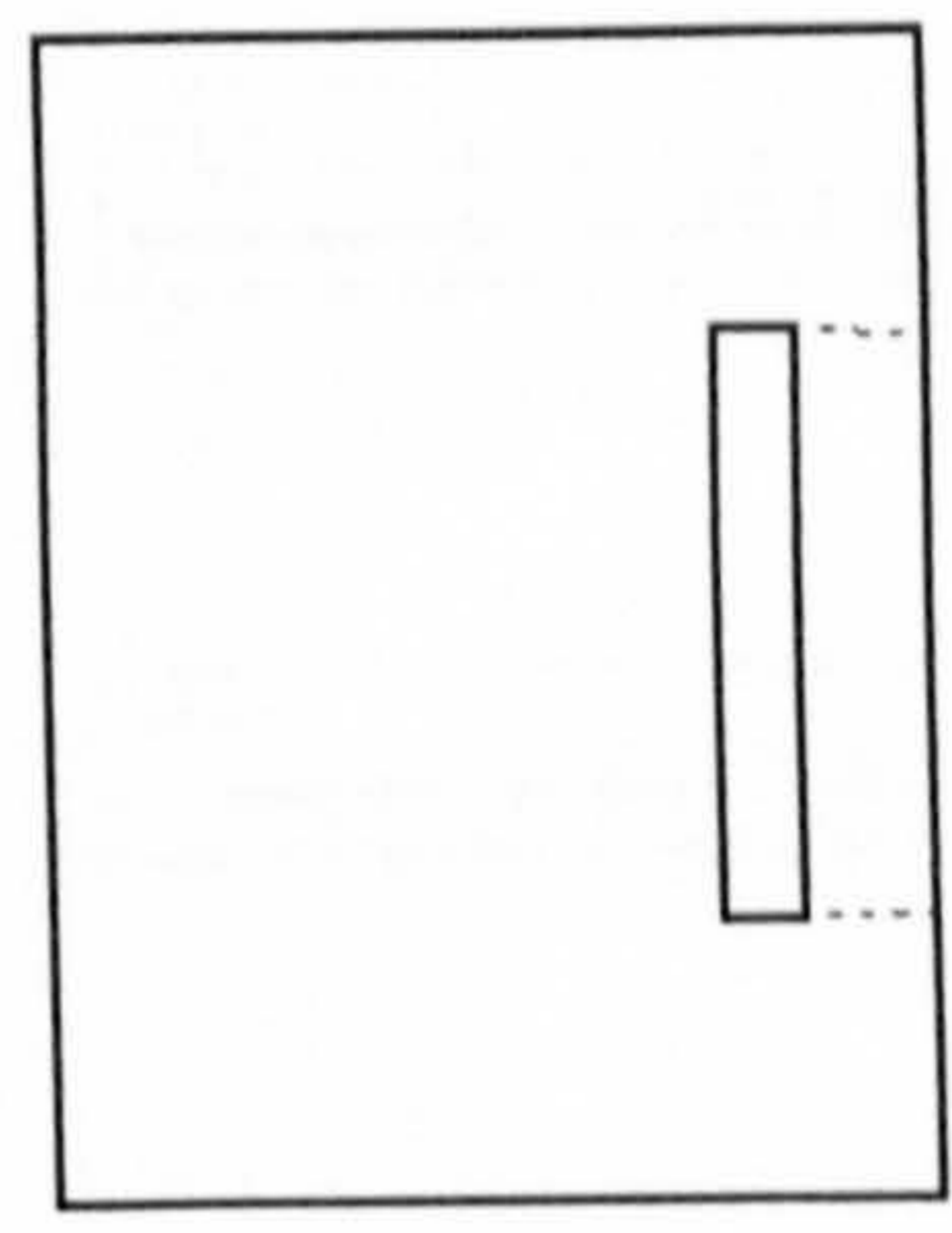

A



I Uns/13

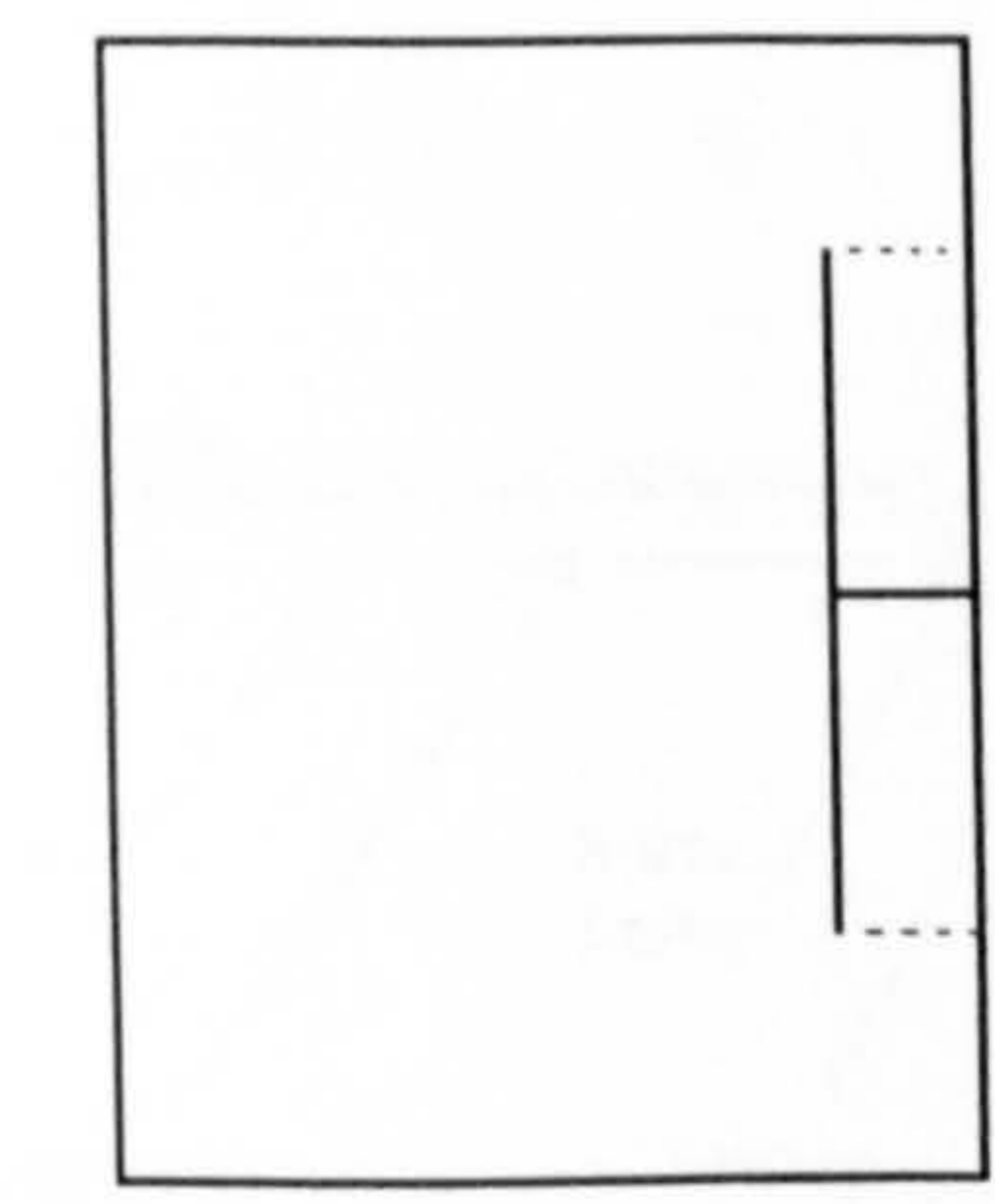

A



I Uns/14

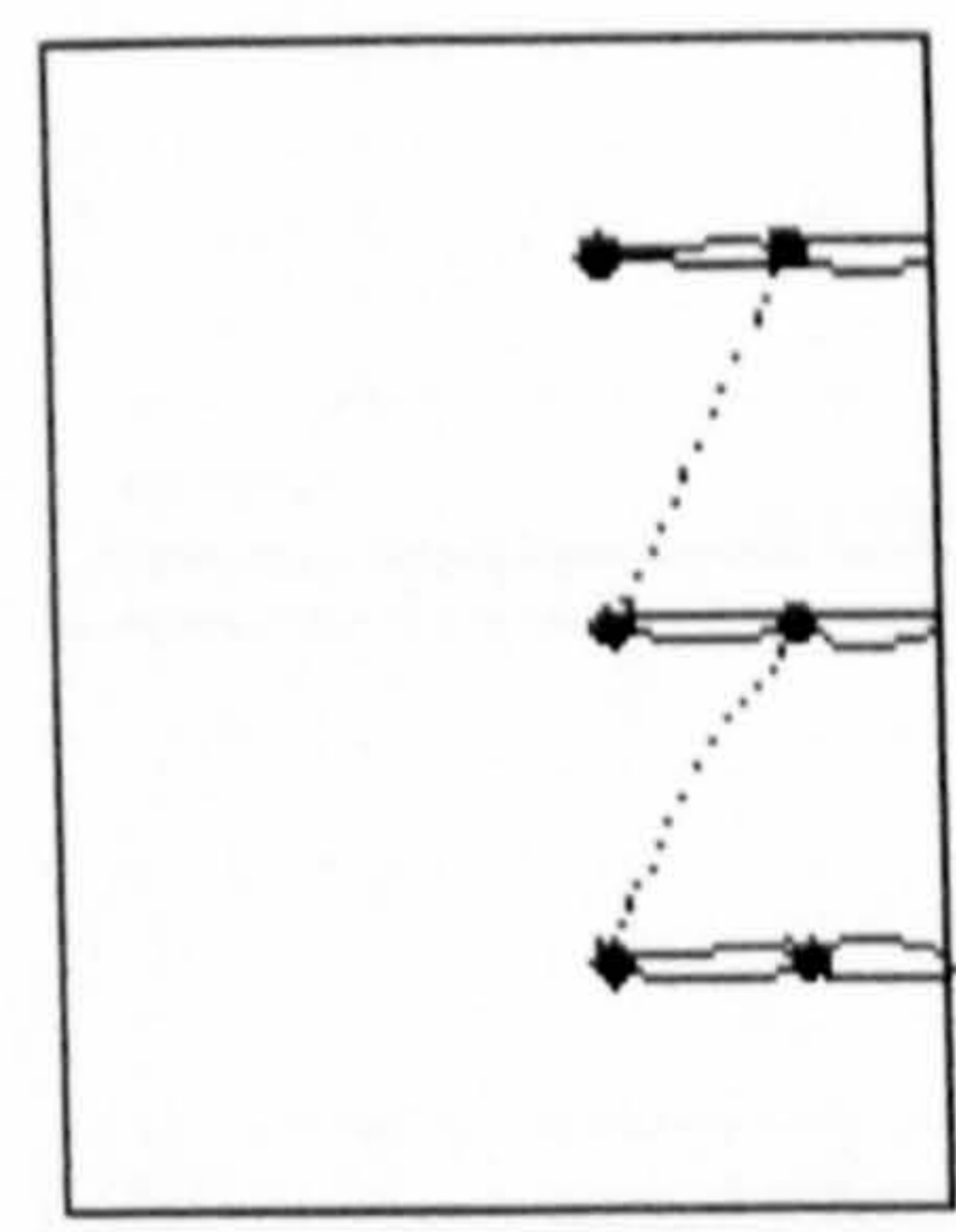

A  
B  
C

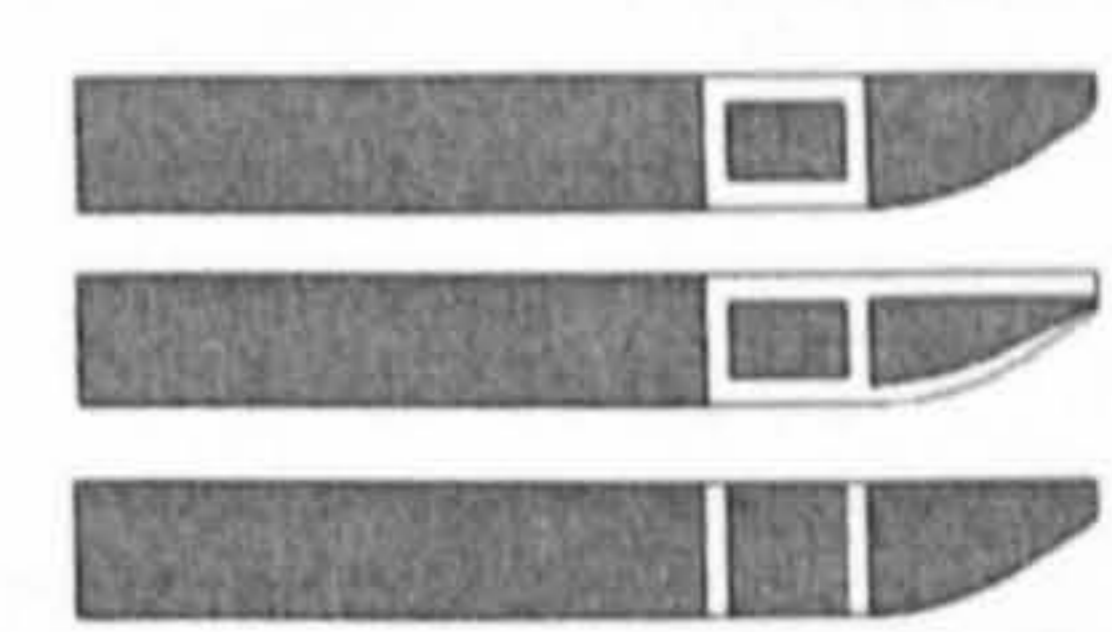

## II Uns Attachement System

### II Uns/A

### II Uns/B

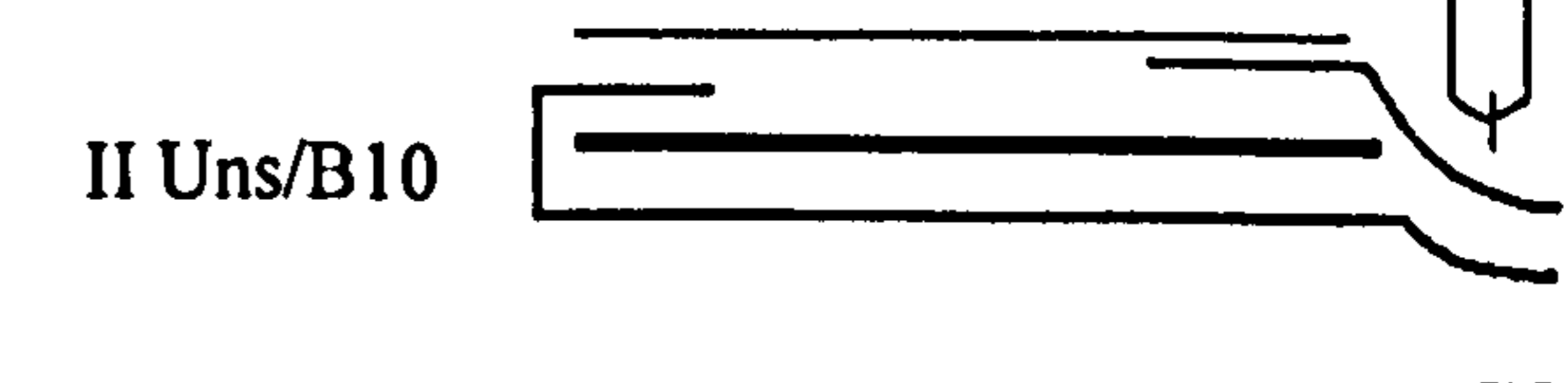
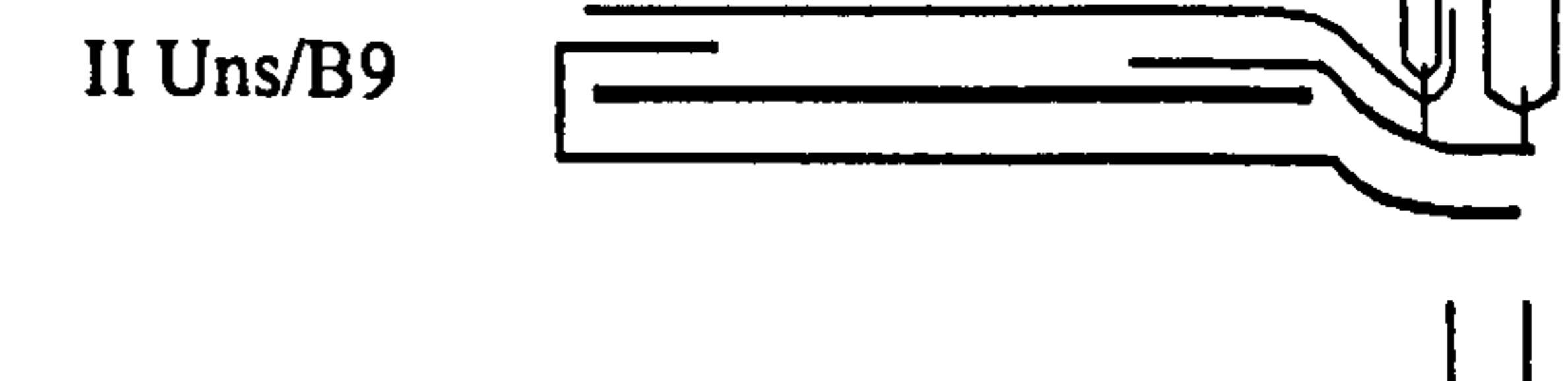
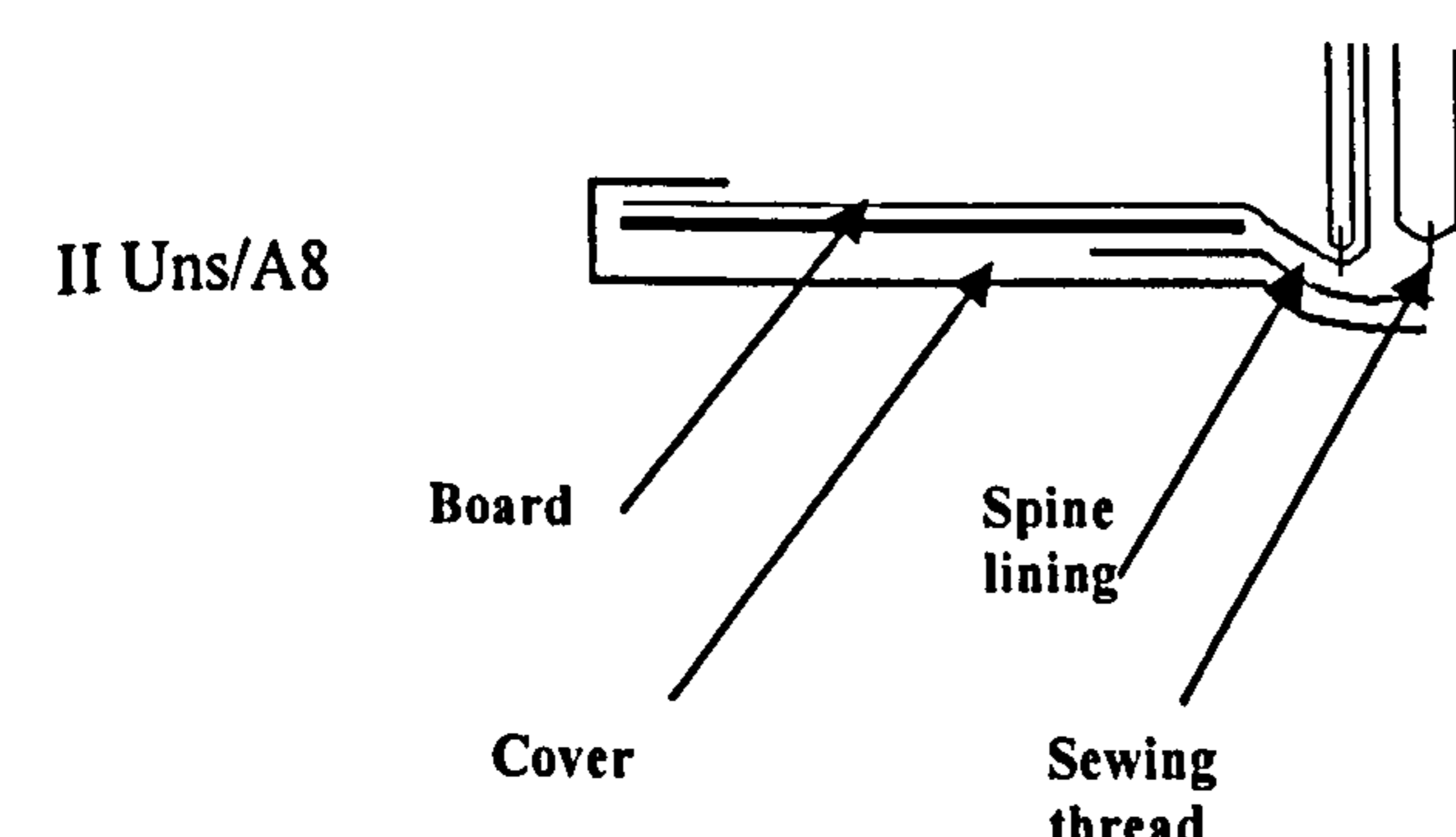
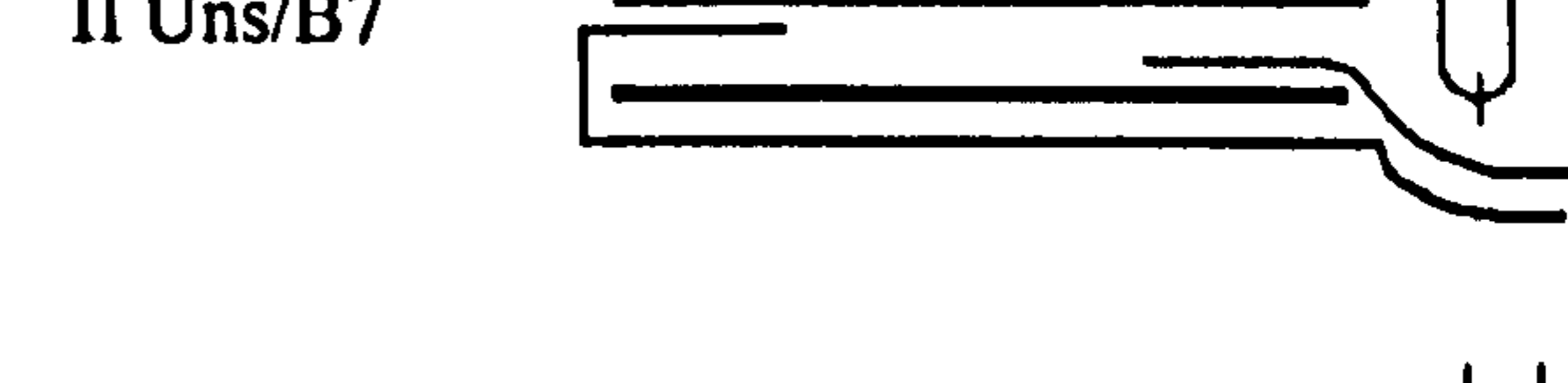
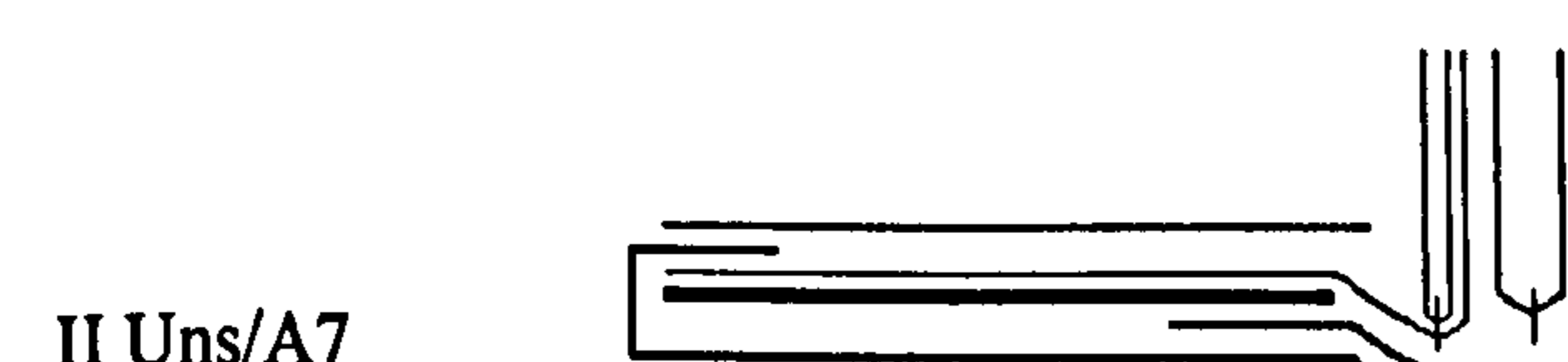
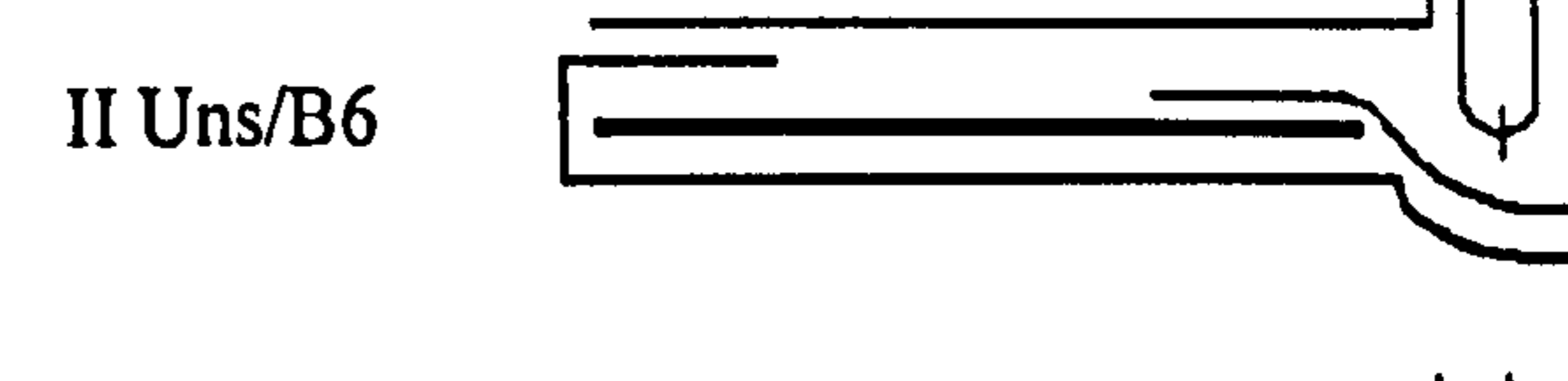
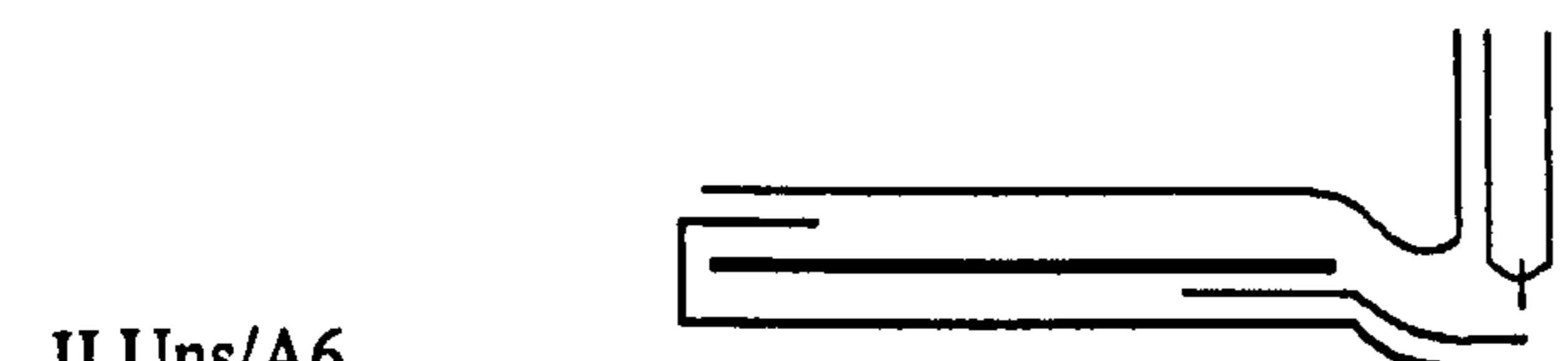
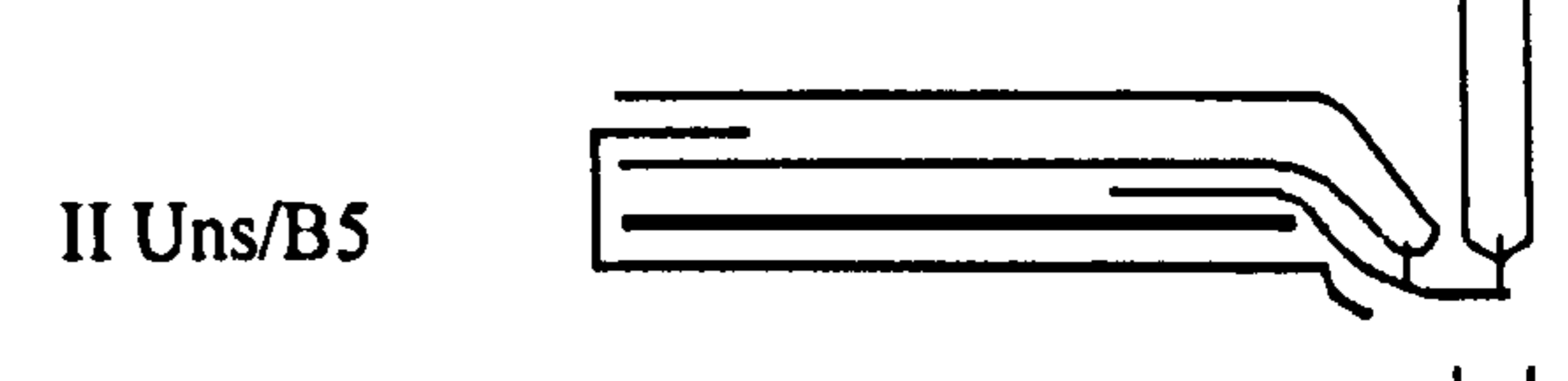
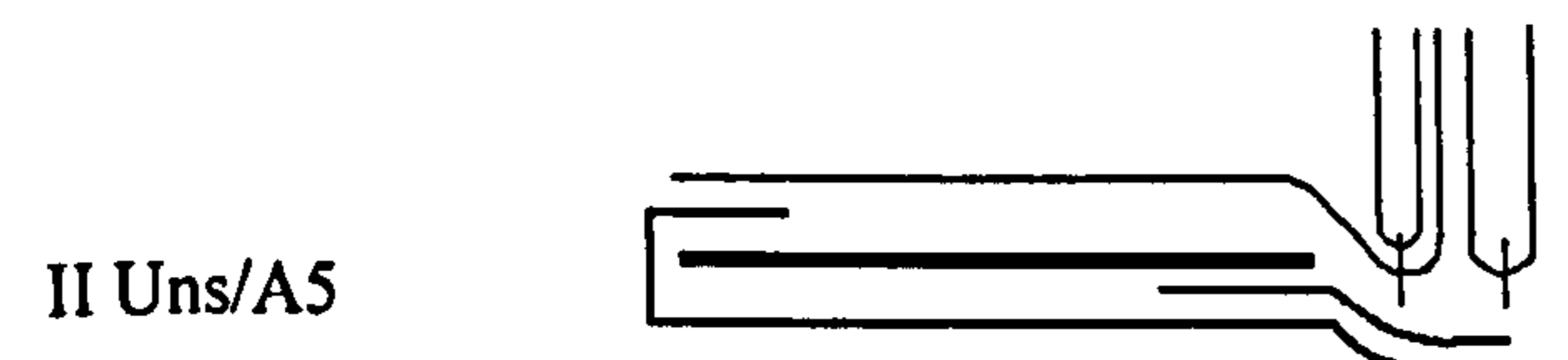
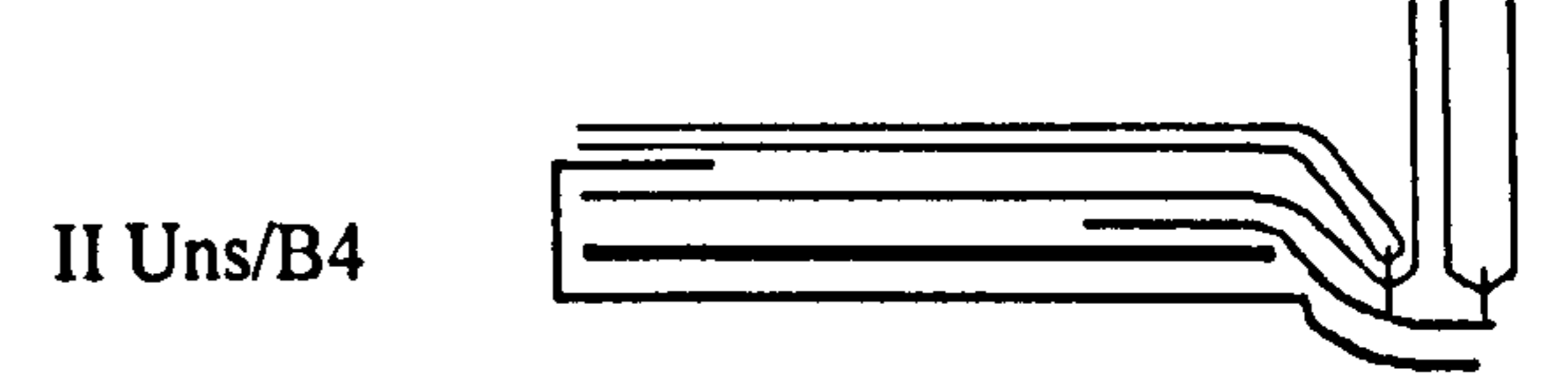
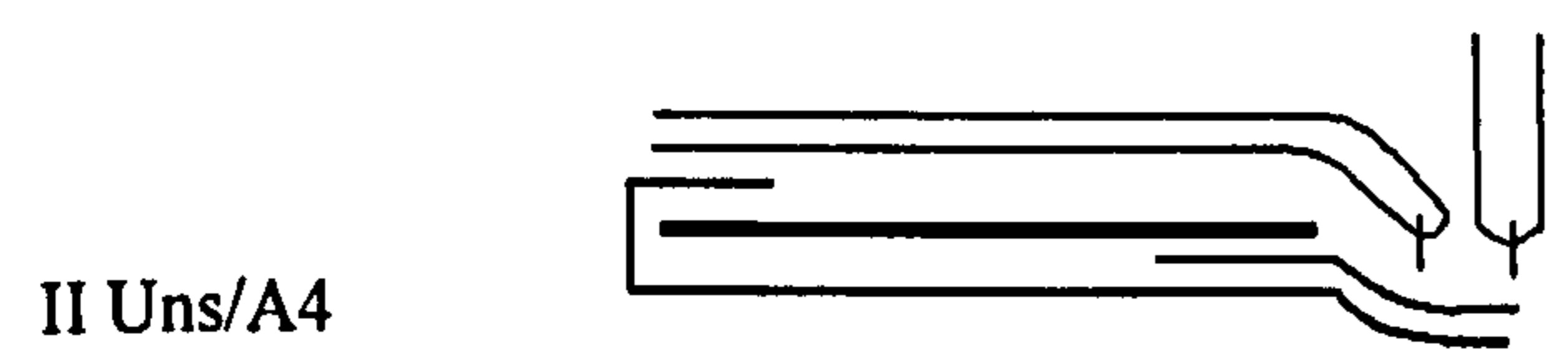
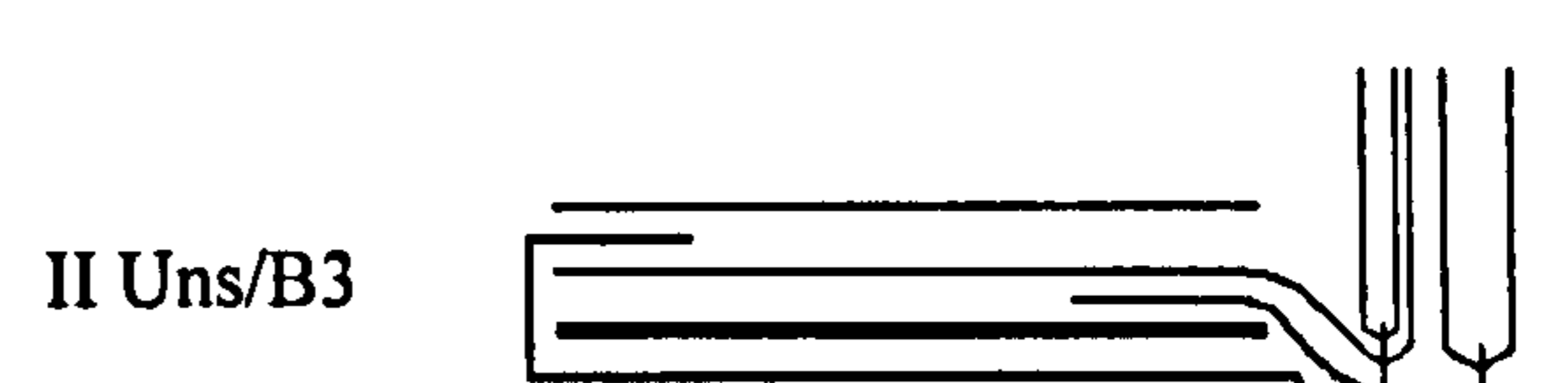
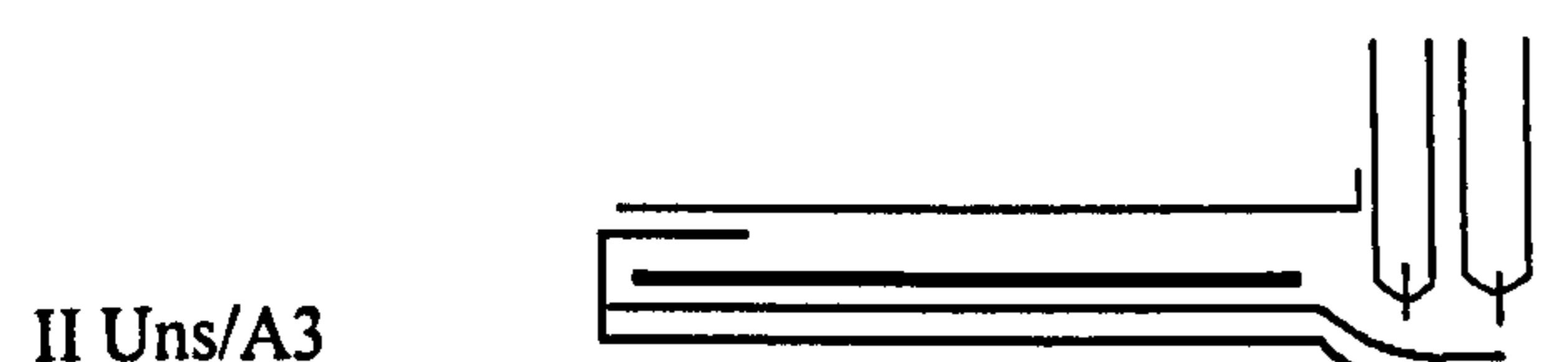
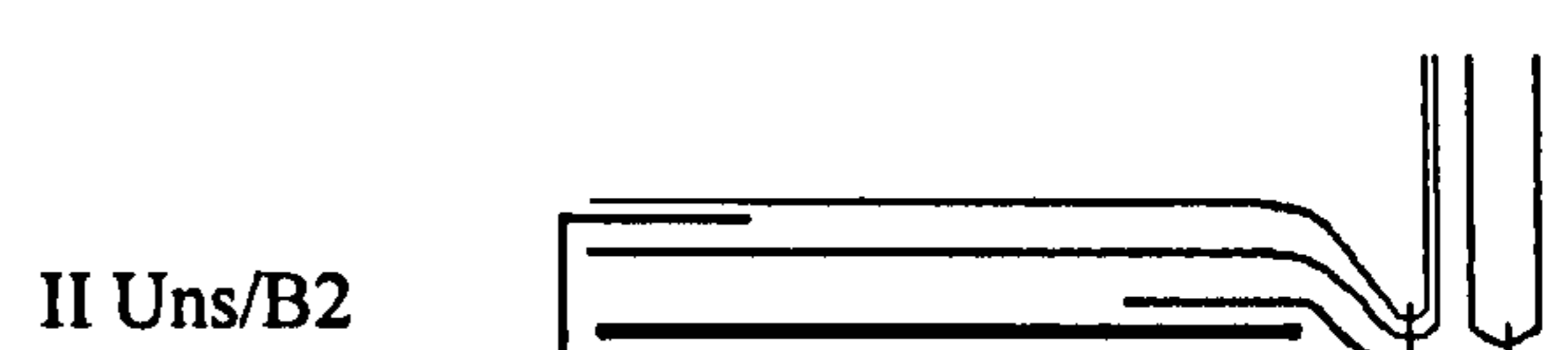
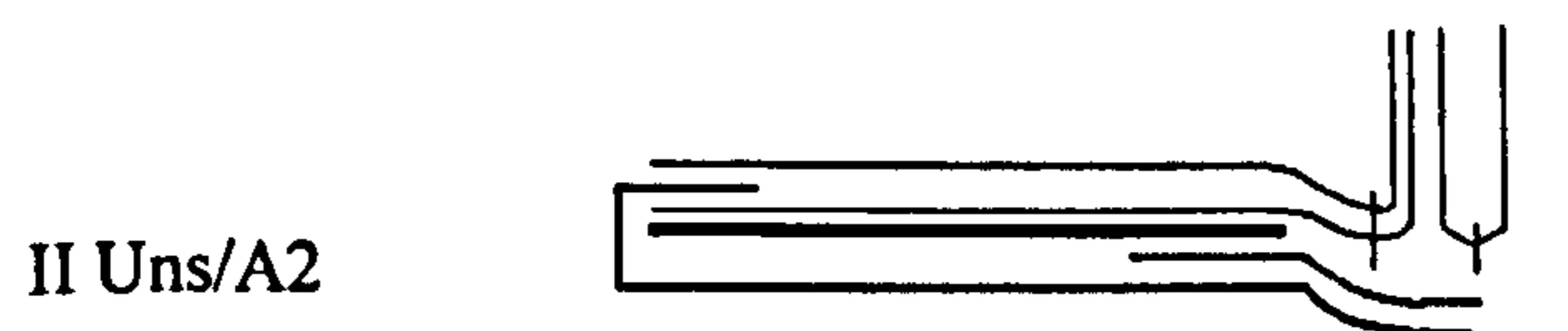
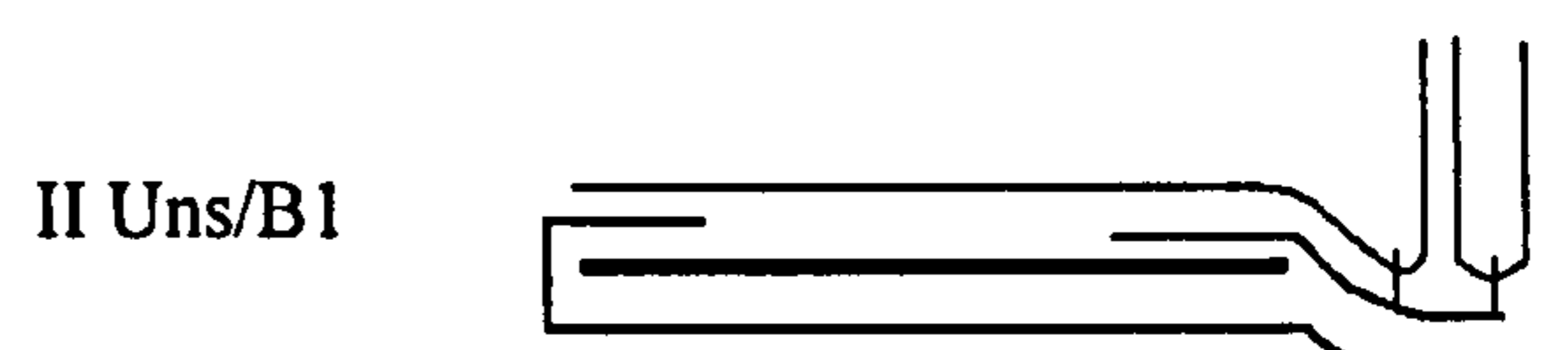
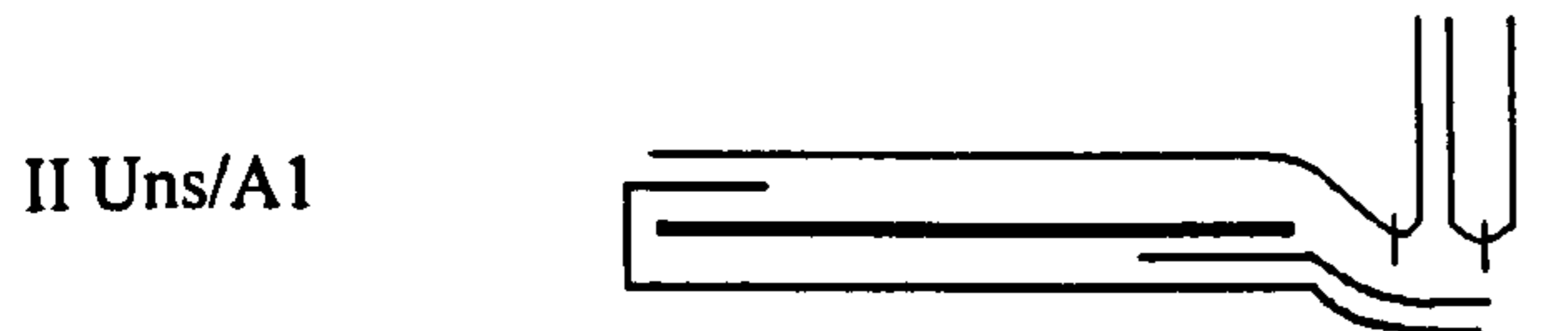



# Sup Attachment Systems

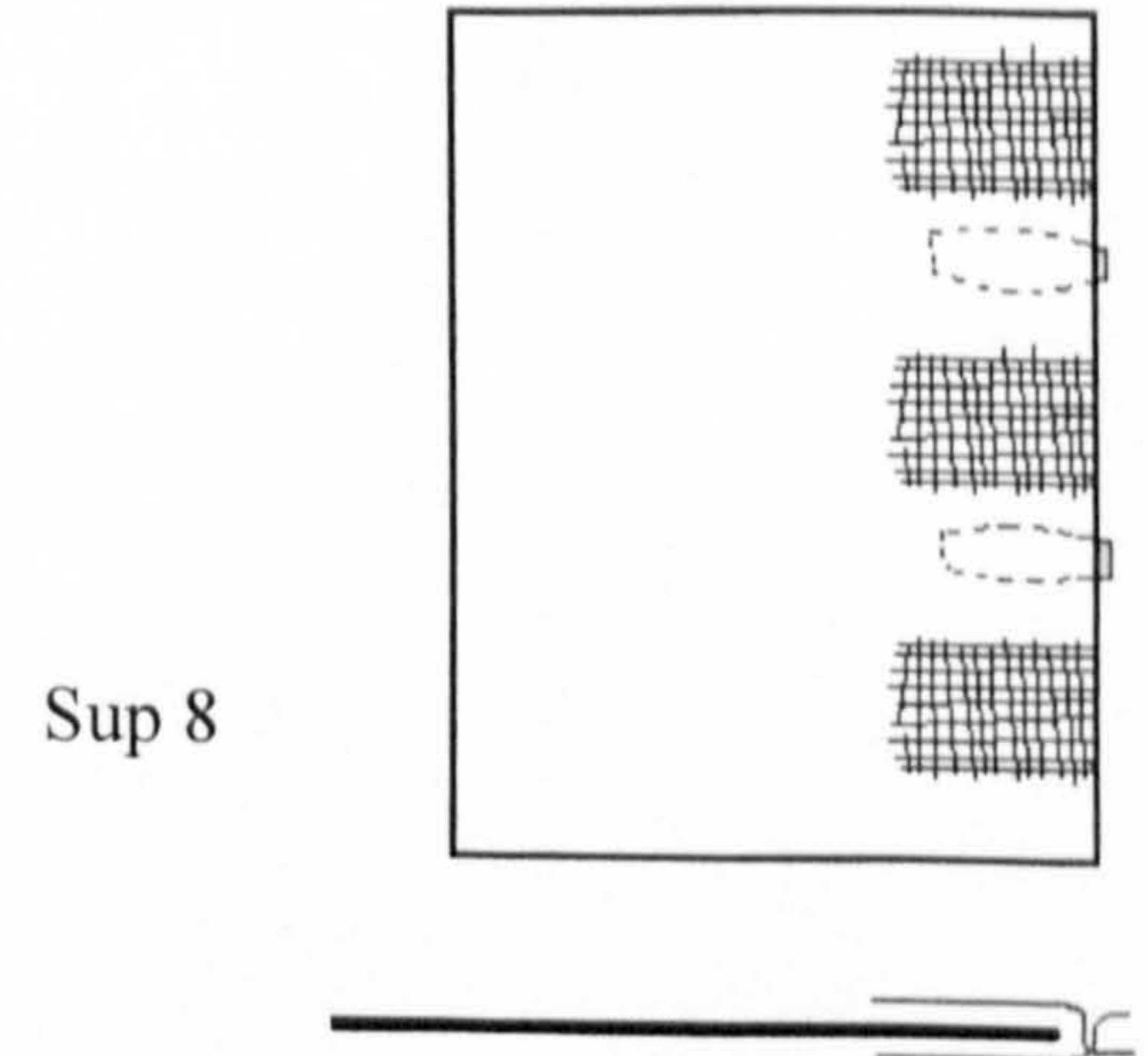
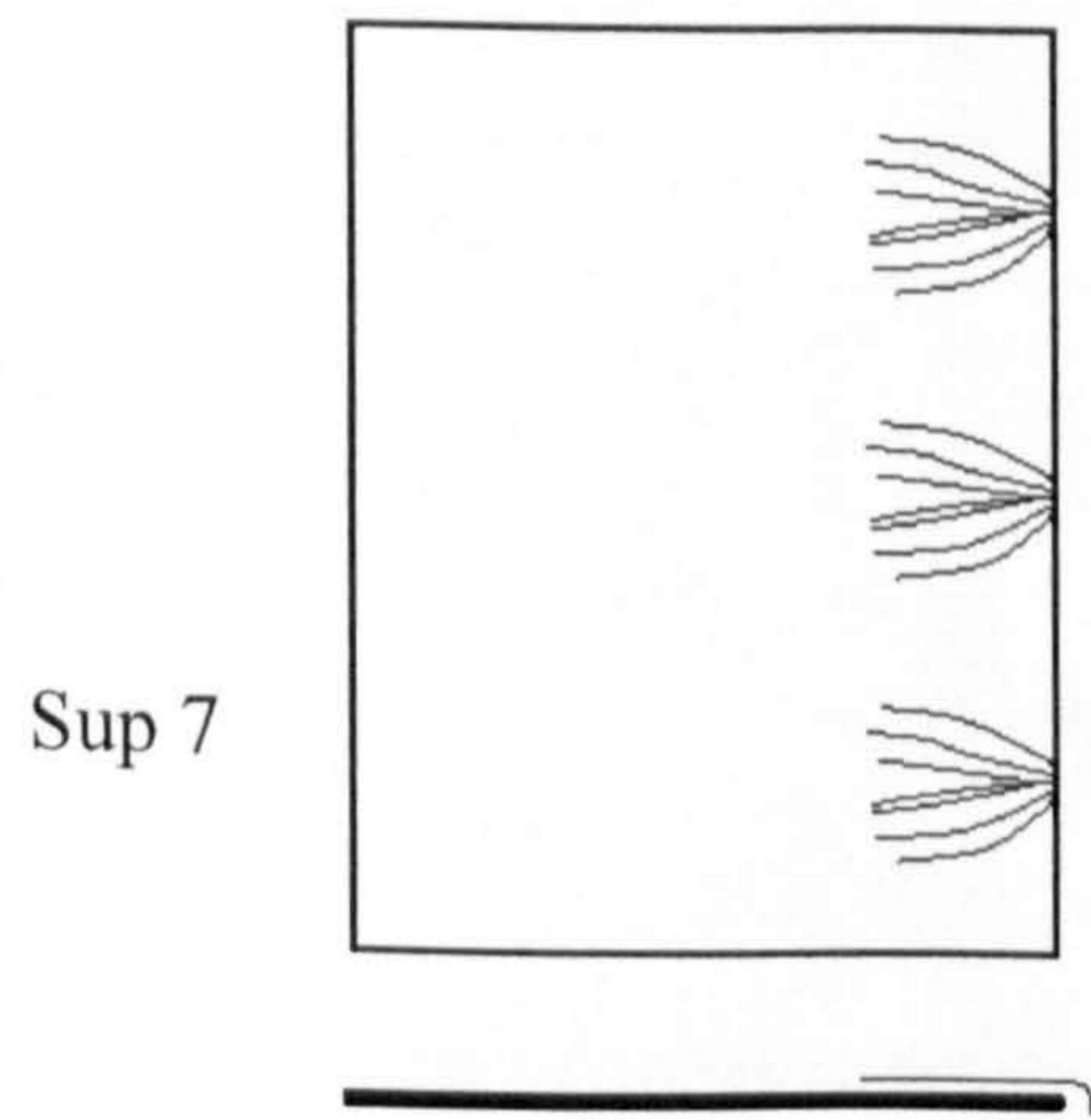
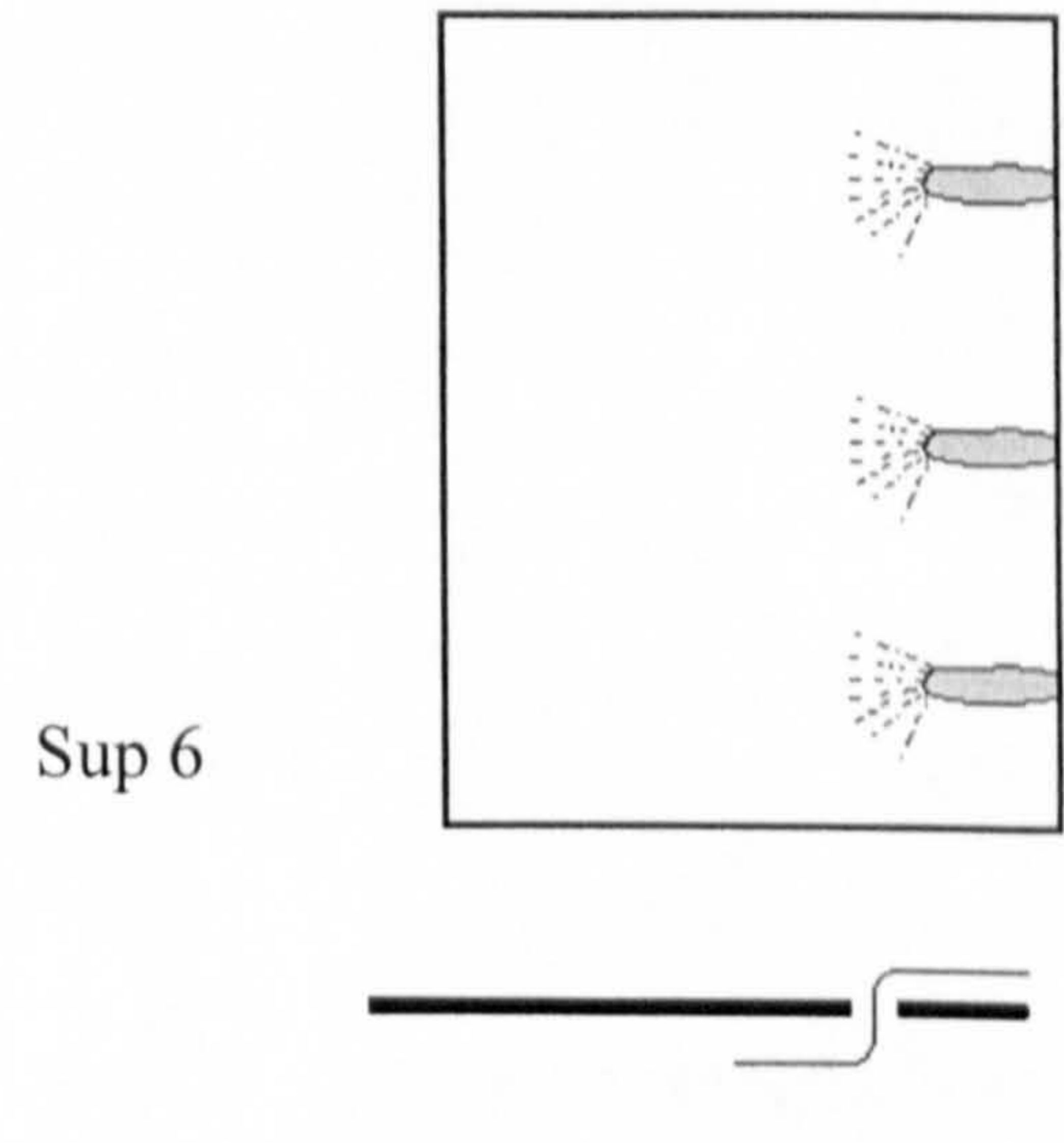
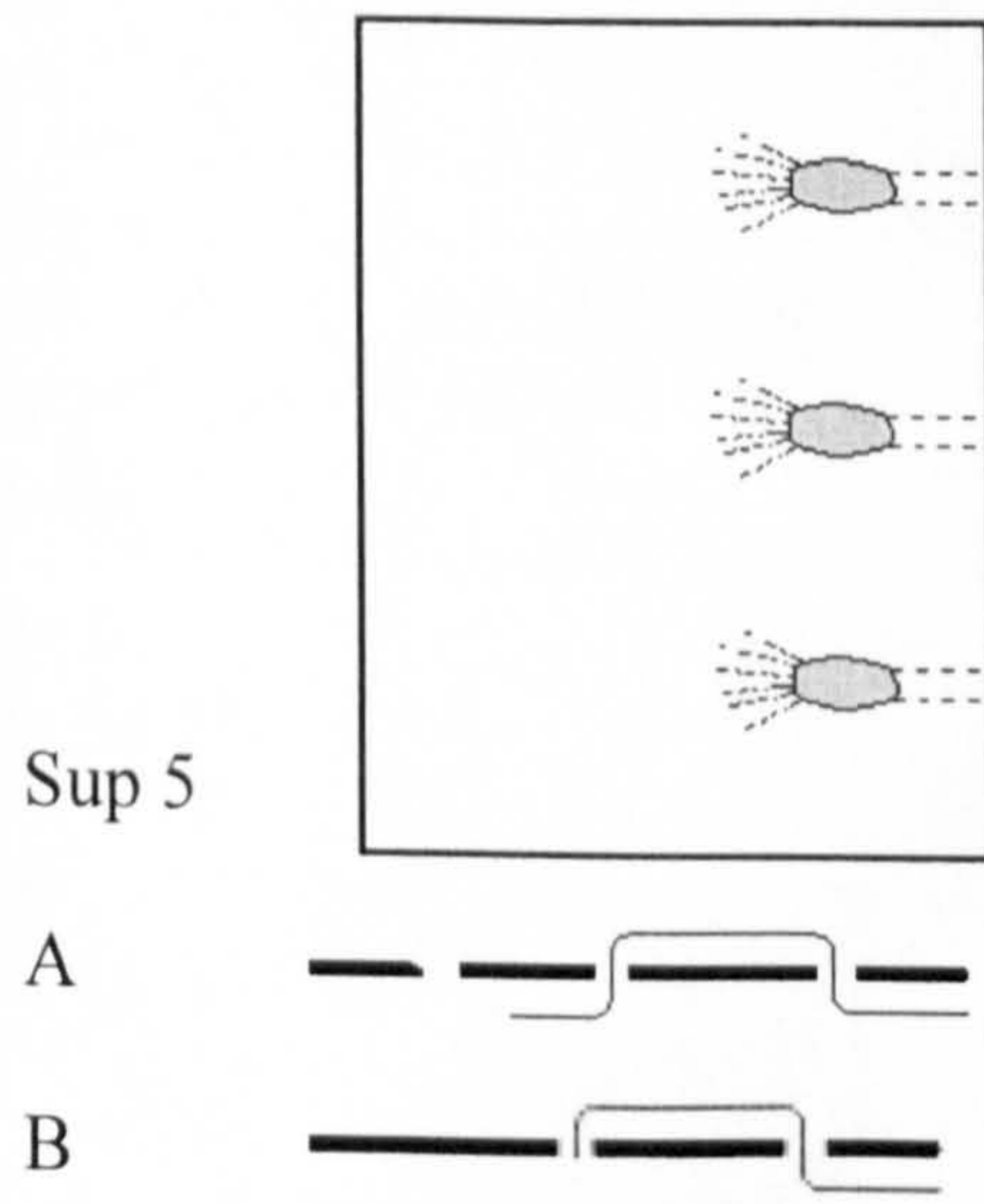
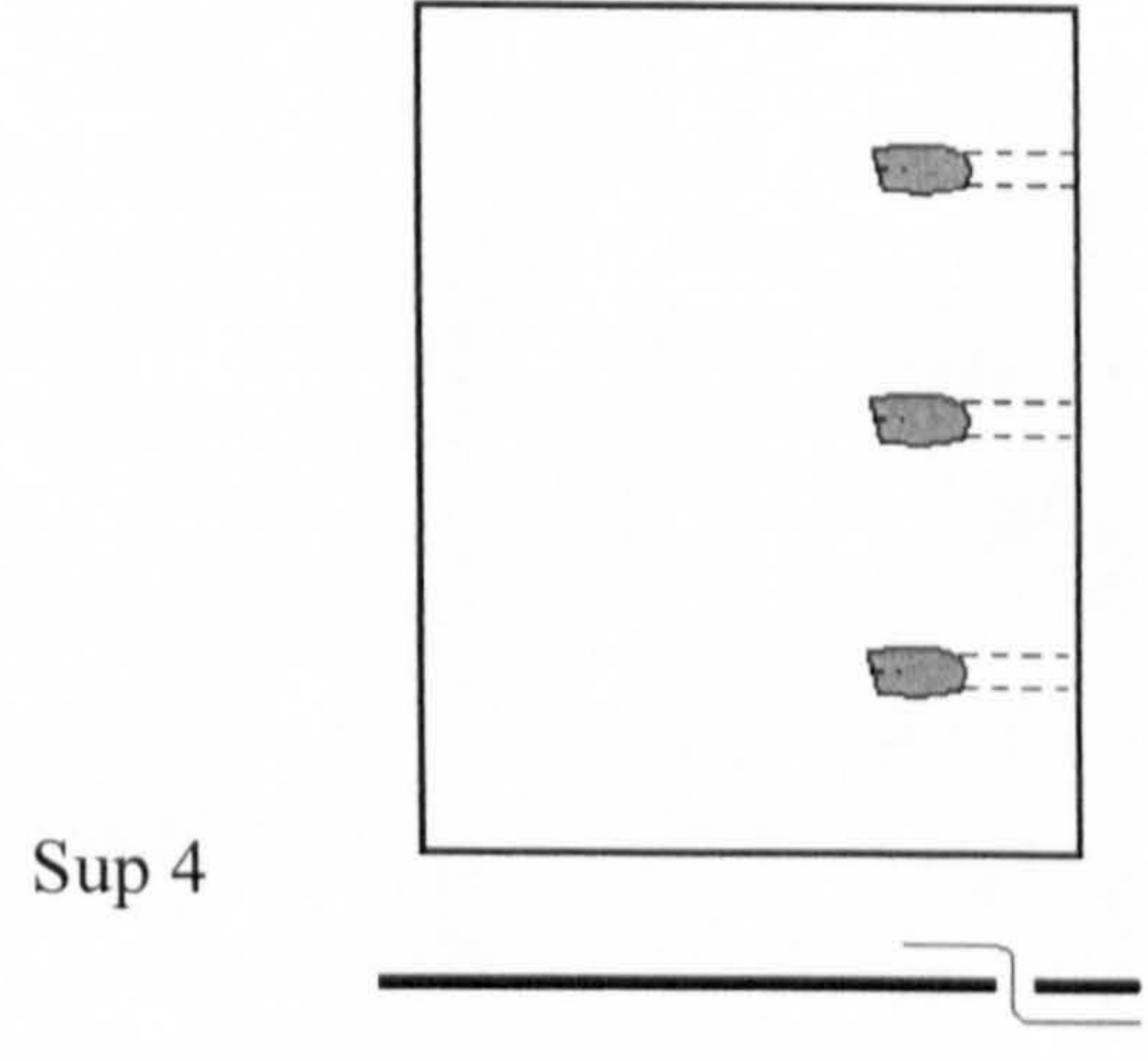
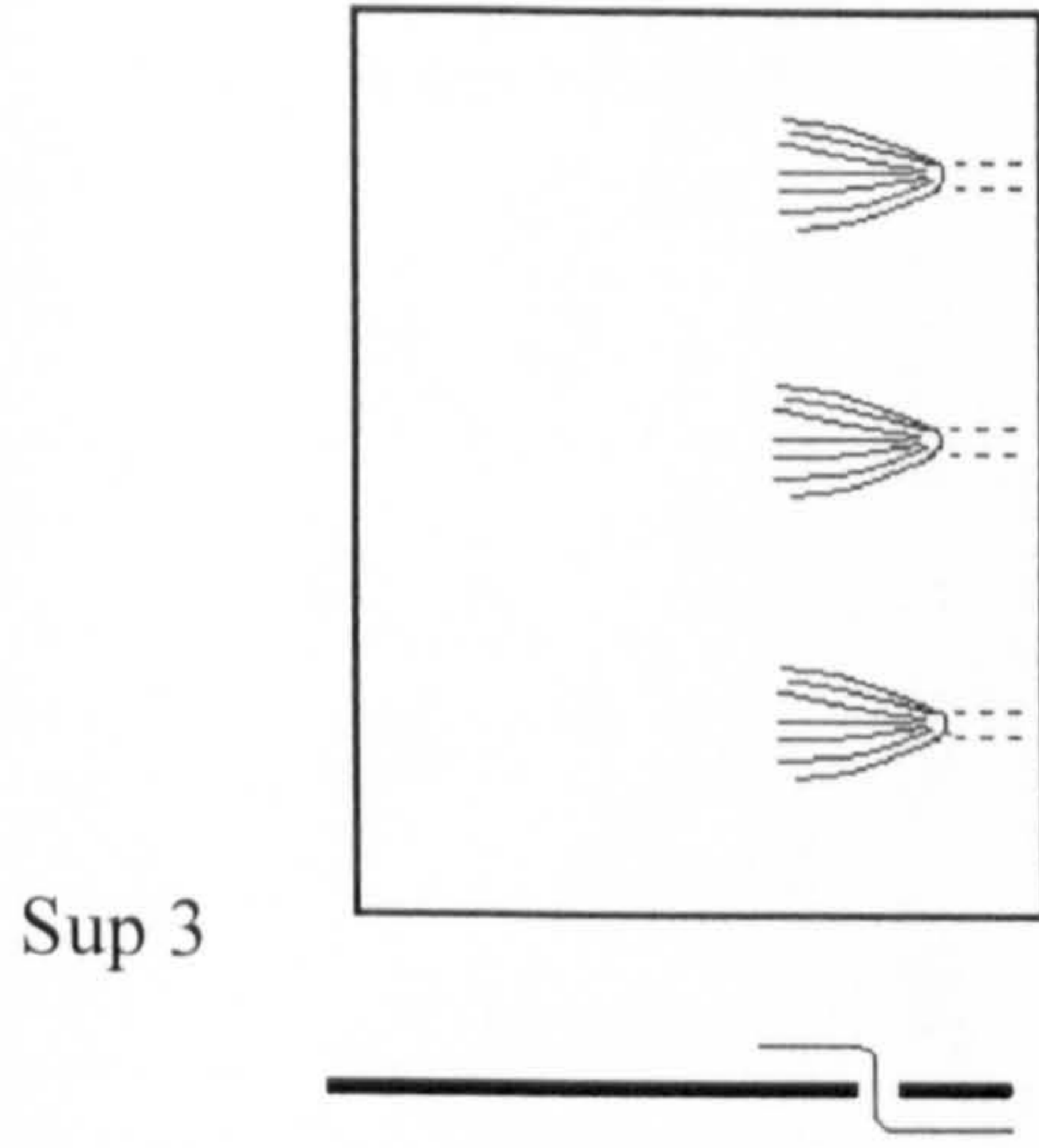
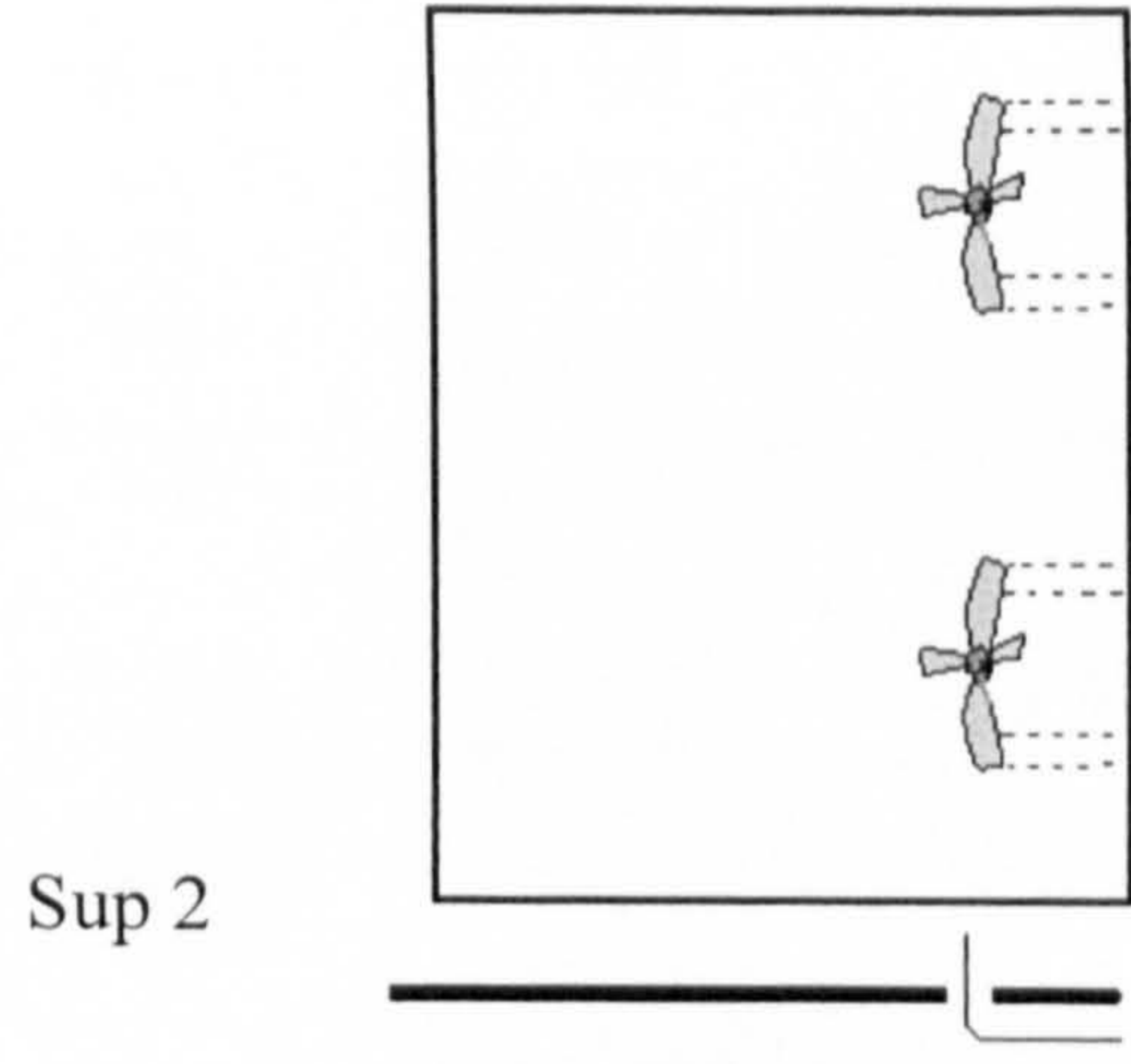
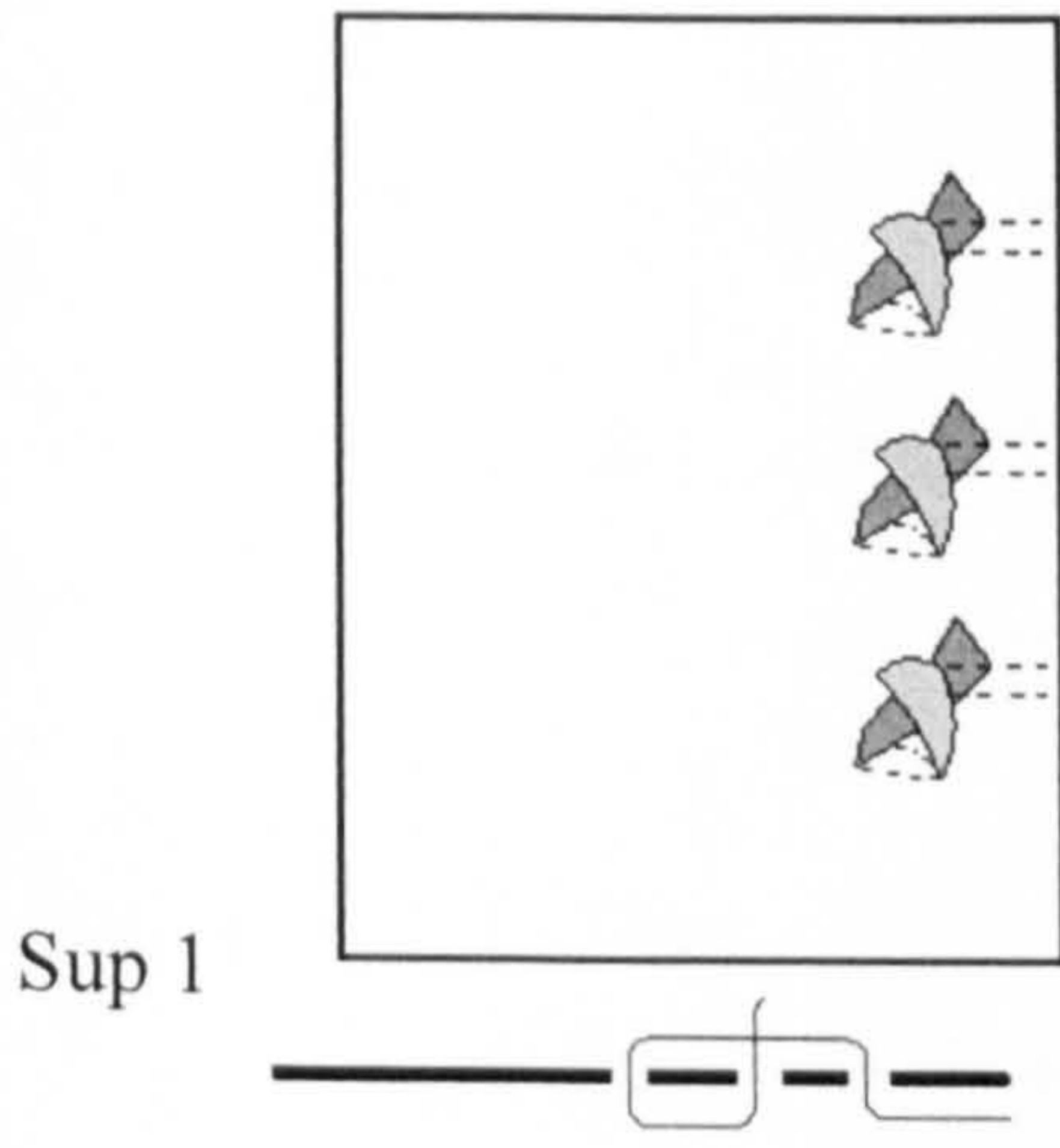

Sup 9  
A

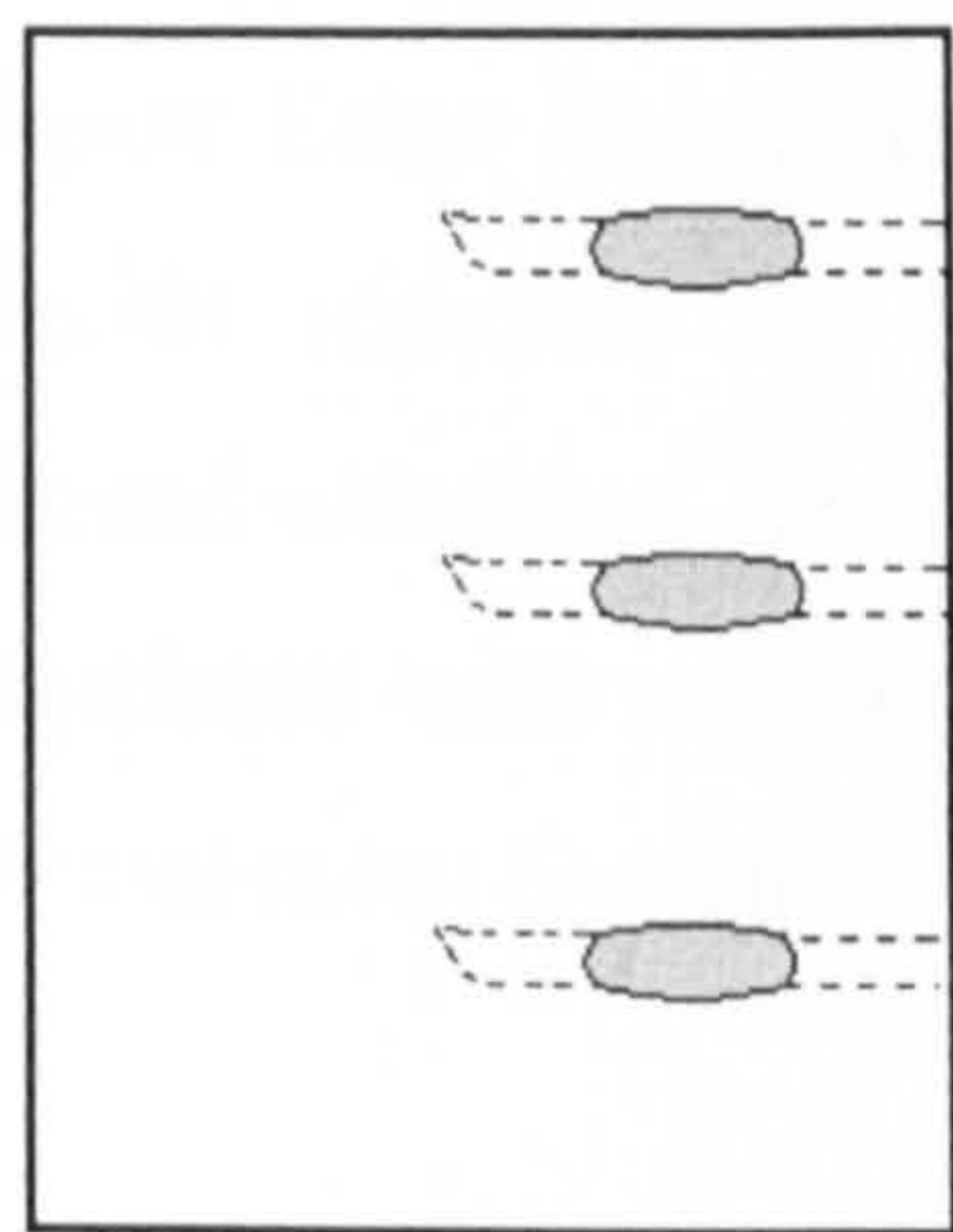

B

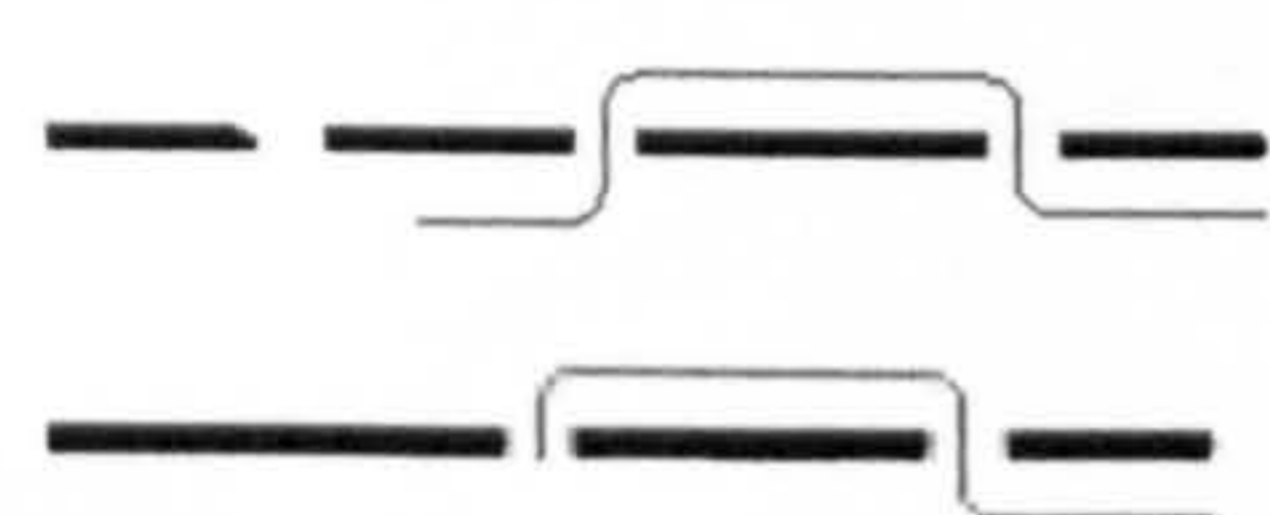

Sup 10

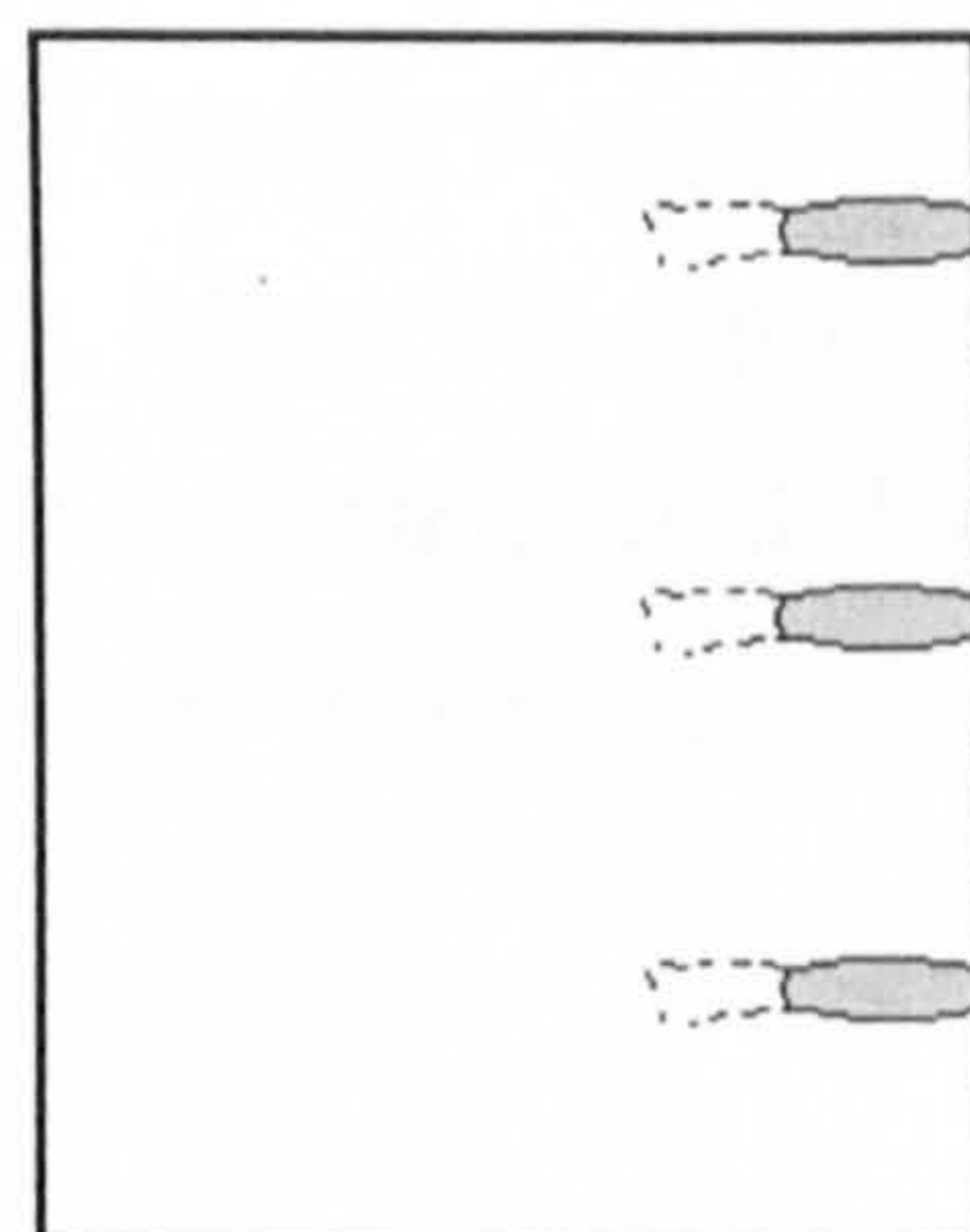

Sup 11

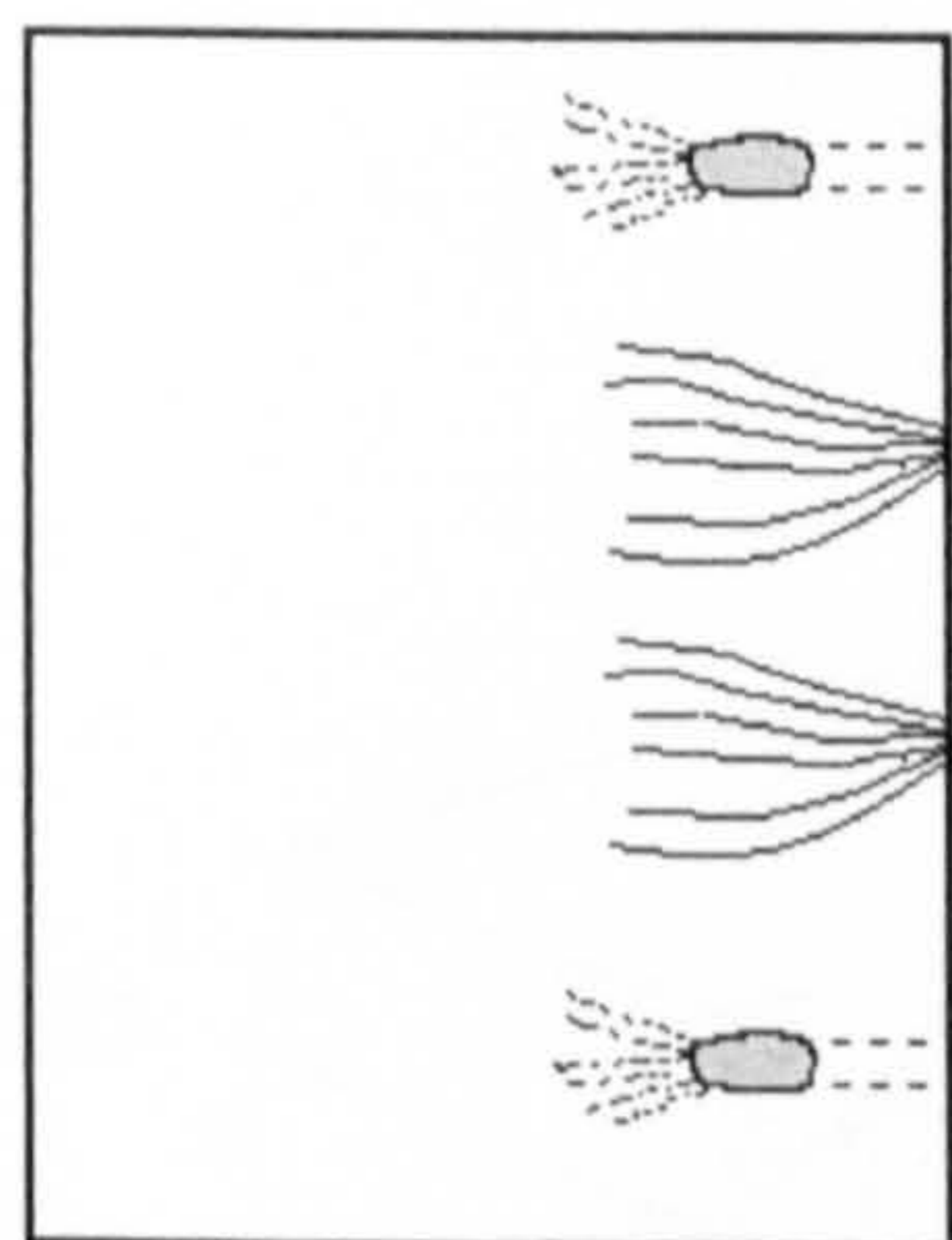

Sup 12

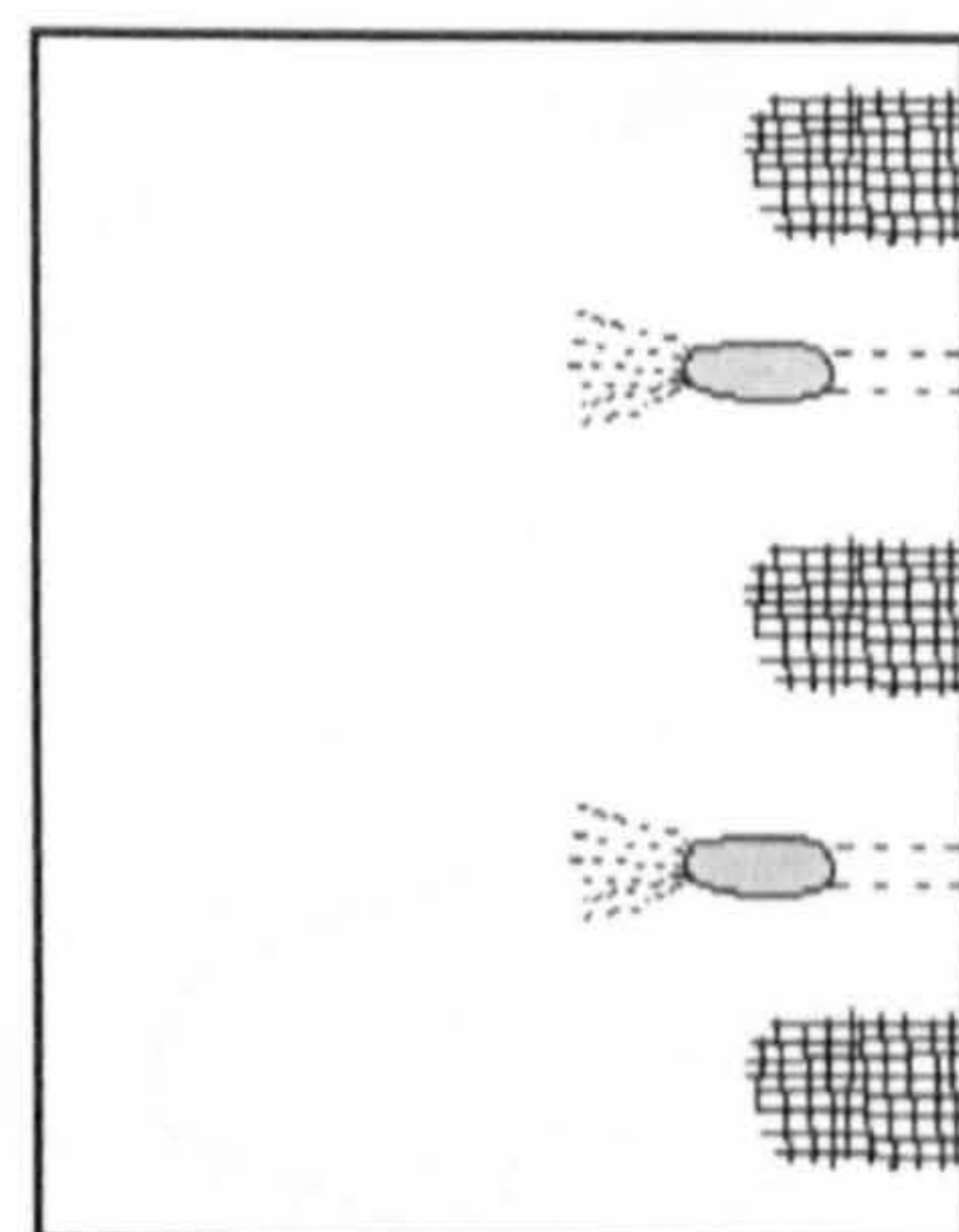

Sup 13

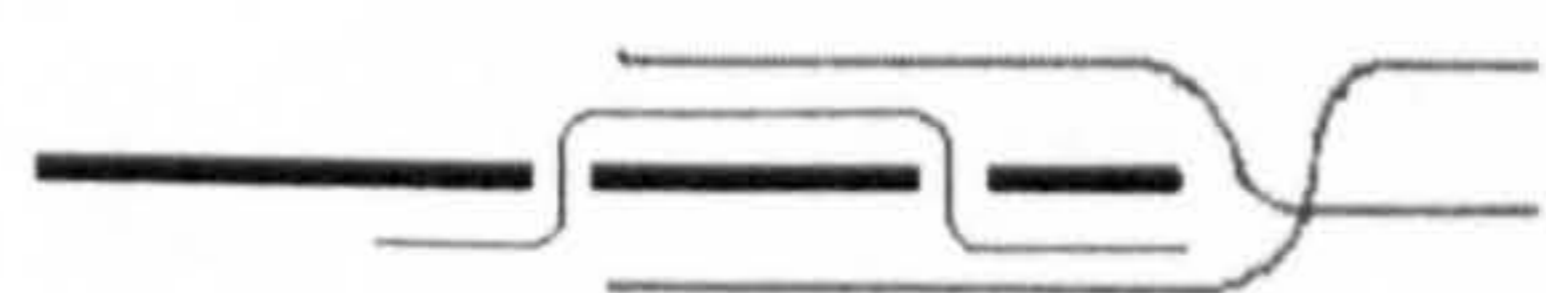
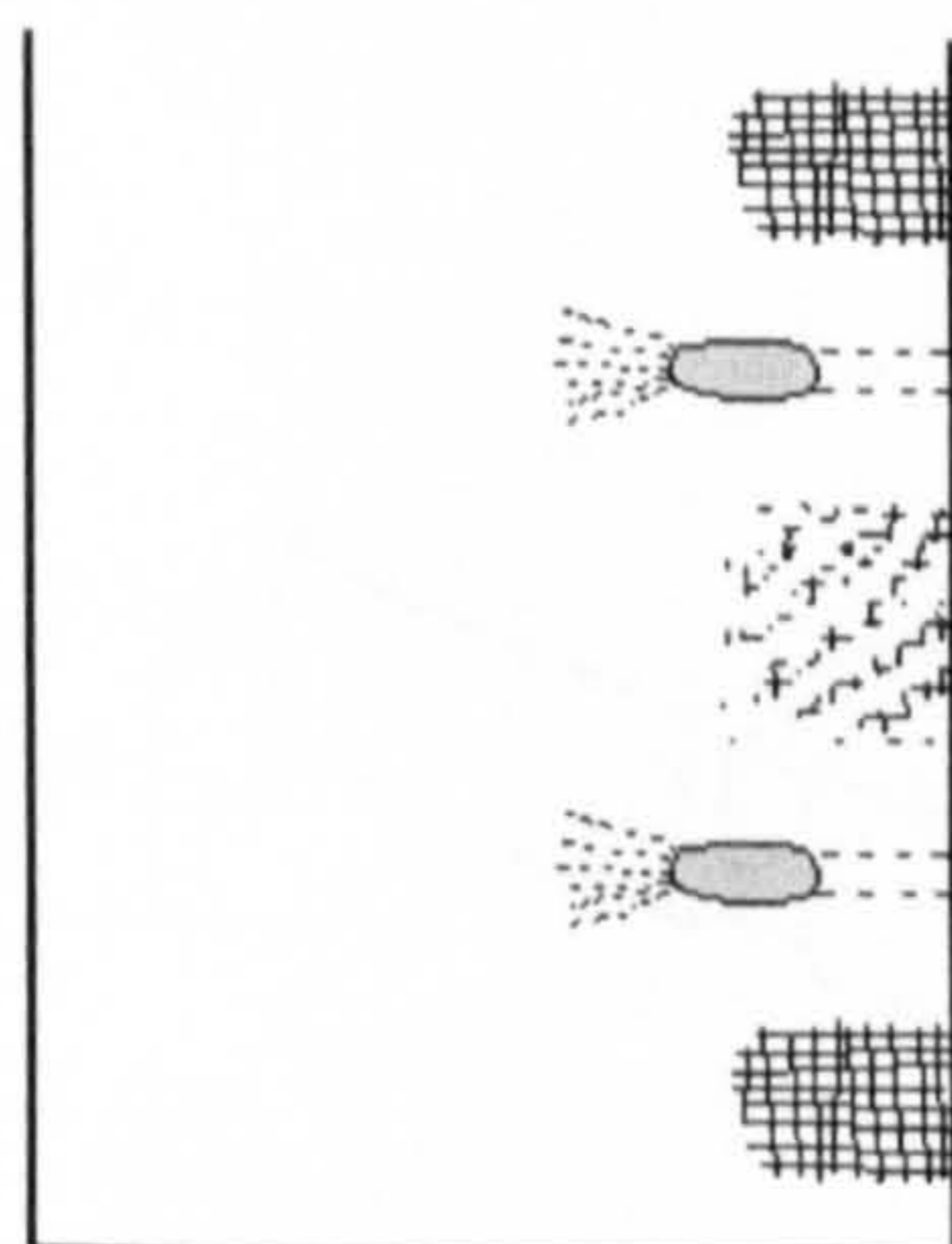

Sup 14

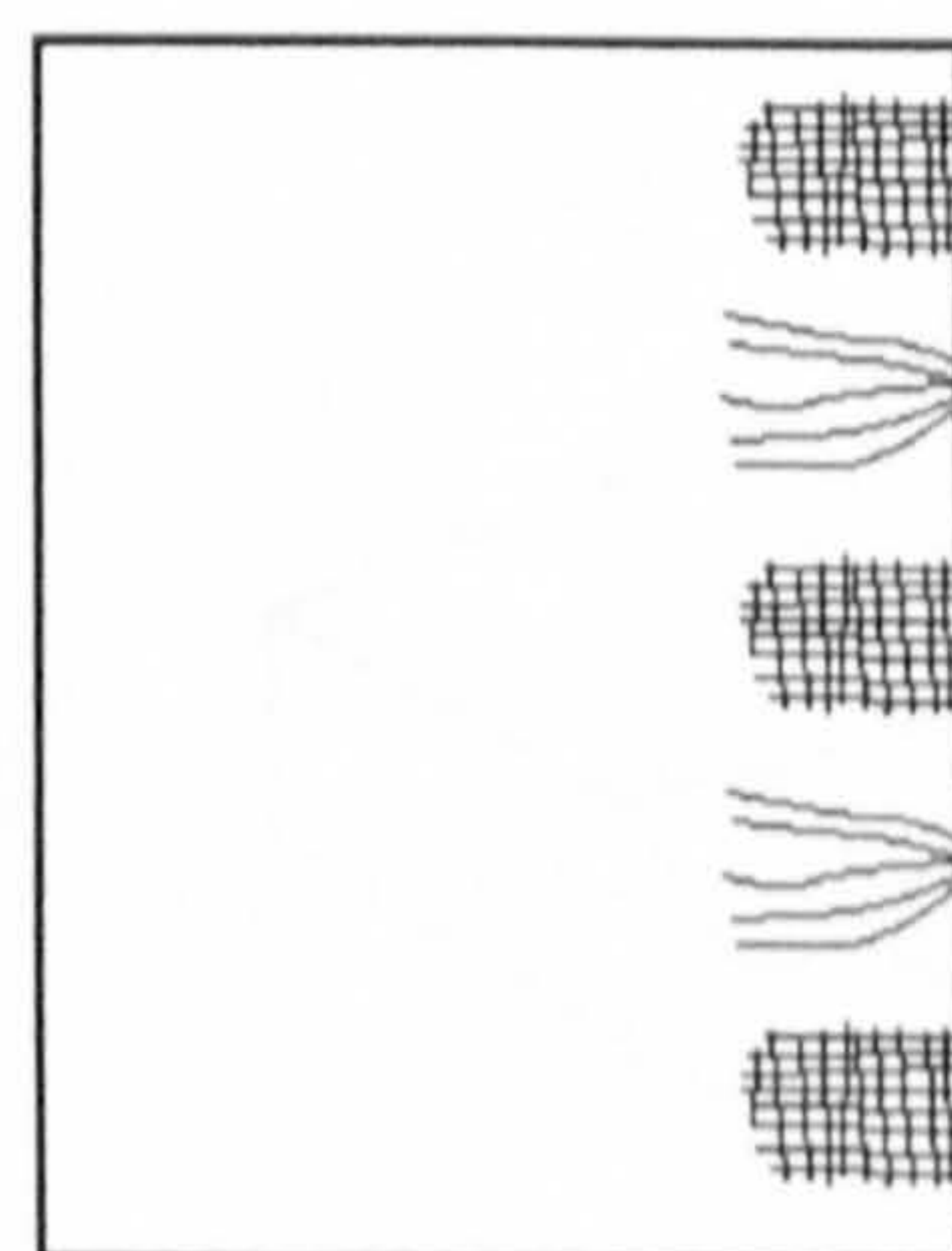

Sup 15

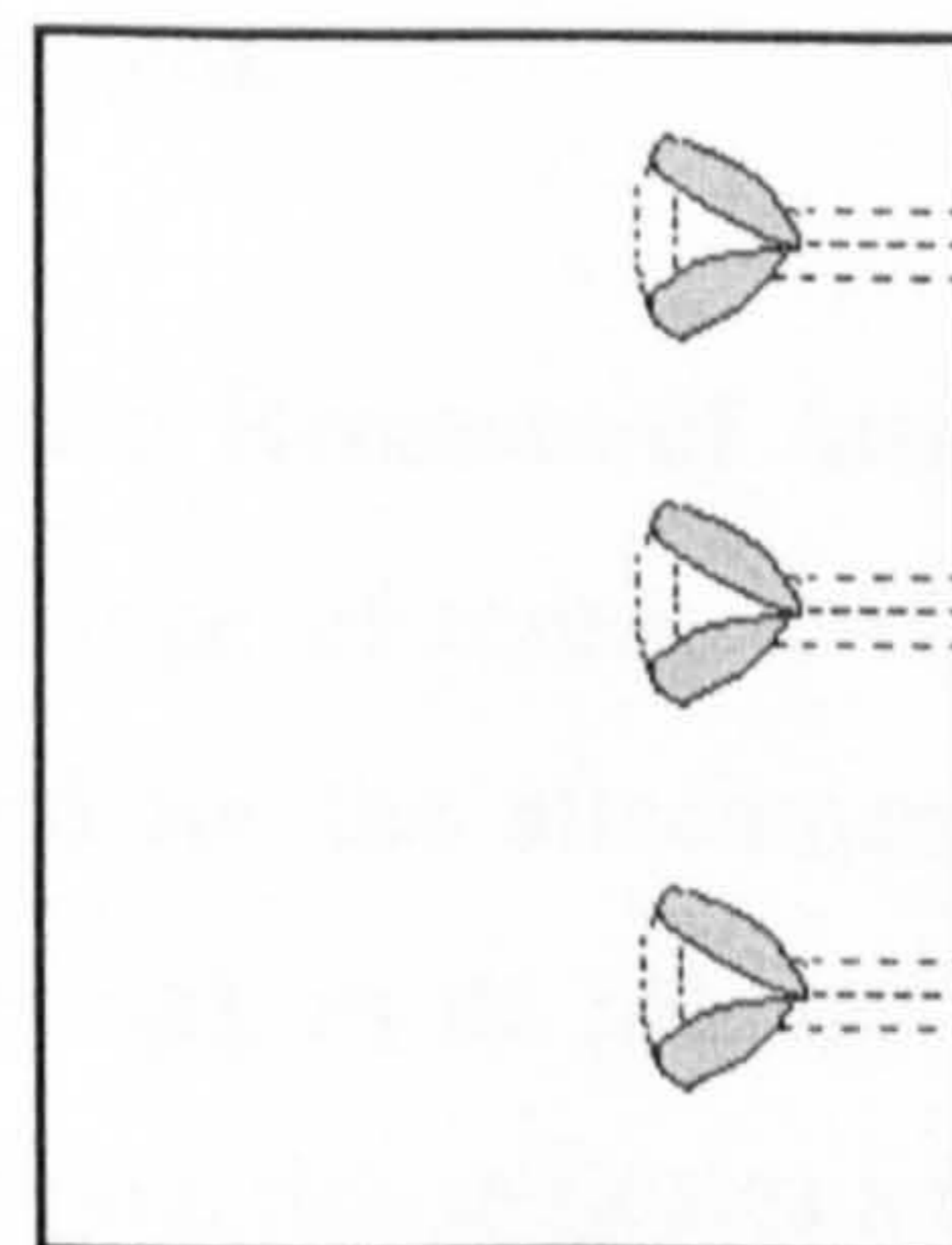

Sup 16

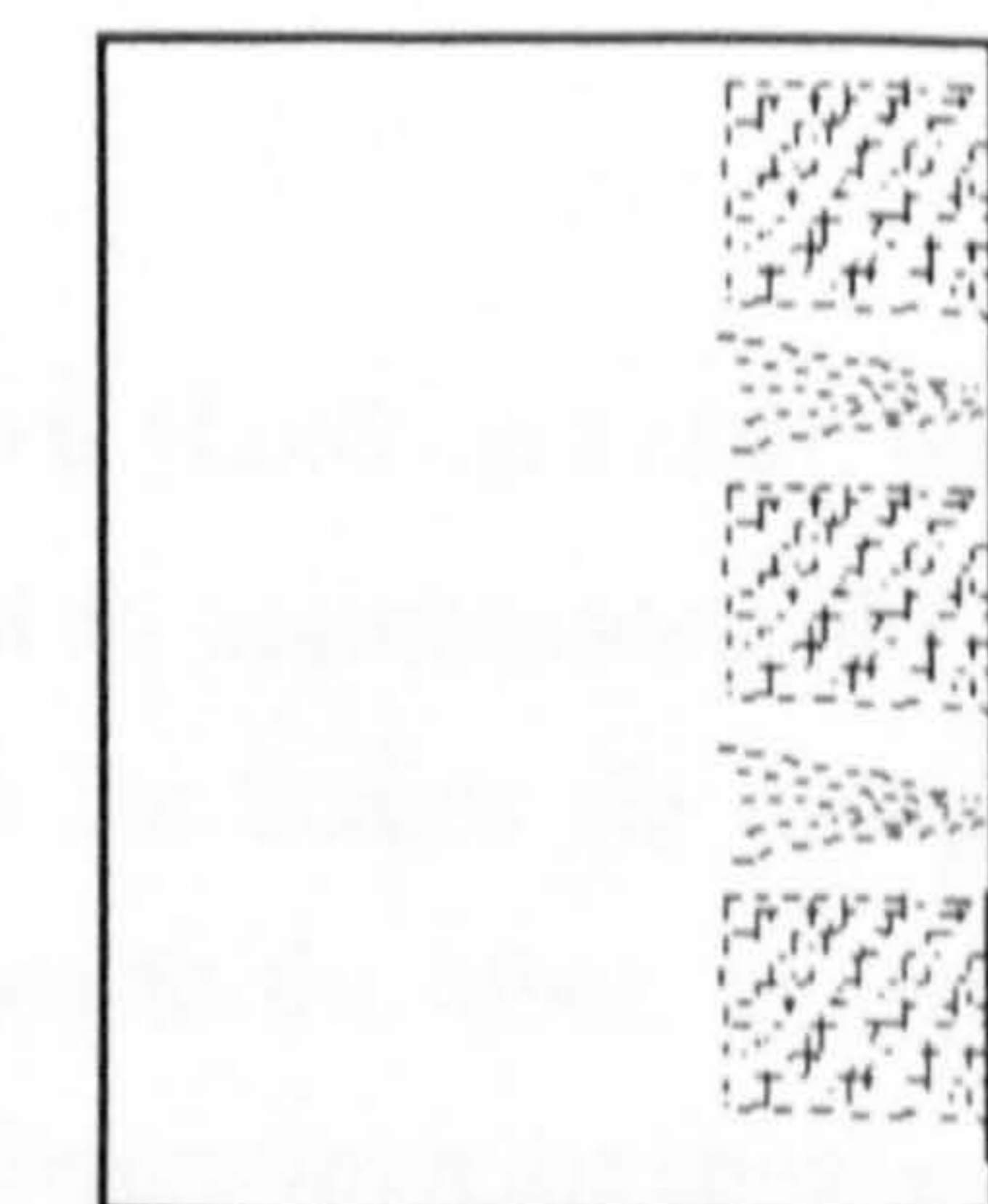

**Spine Edge Recess for the Attachment Thread/ Sewing Support** [Look-up Field]: indicates the type of the recesses, if any, where the supports or the thread attaching the text-block to the boards are accommodated. Not to be confused with any accommodation tunnel when there is one, indicated in the Attachment System.

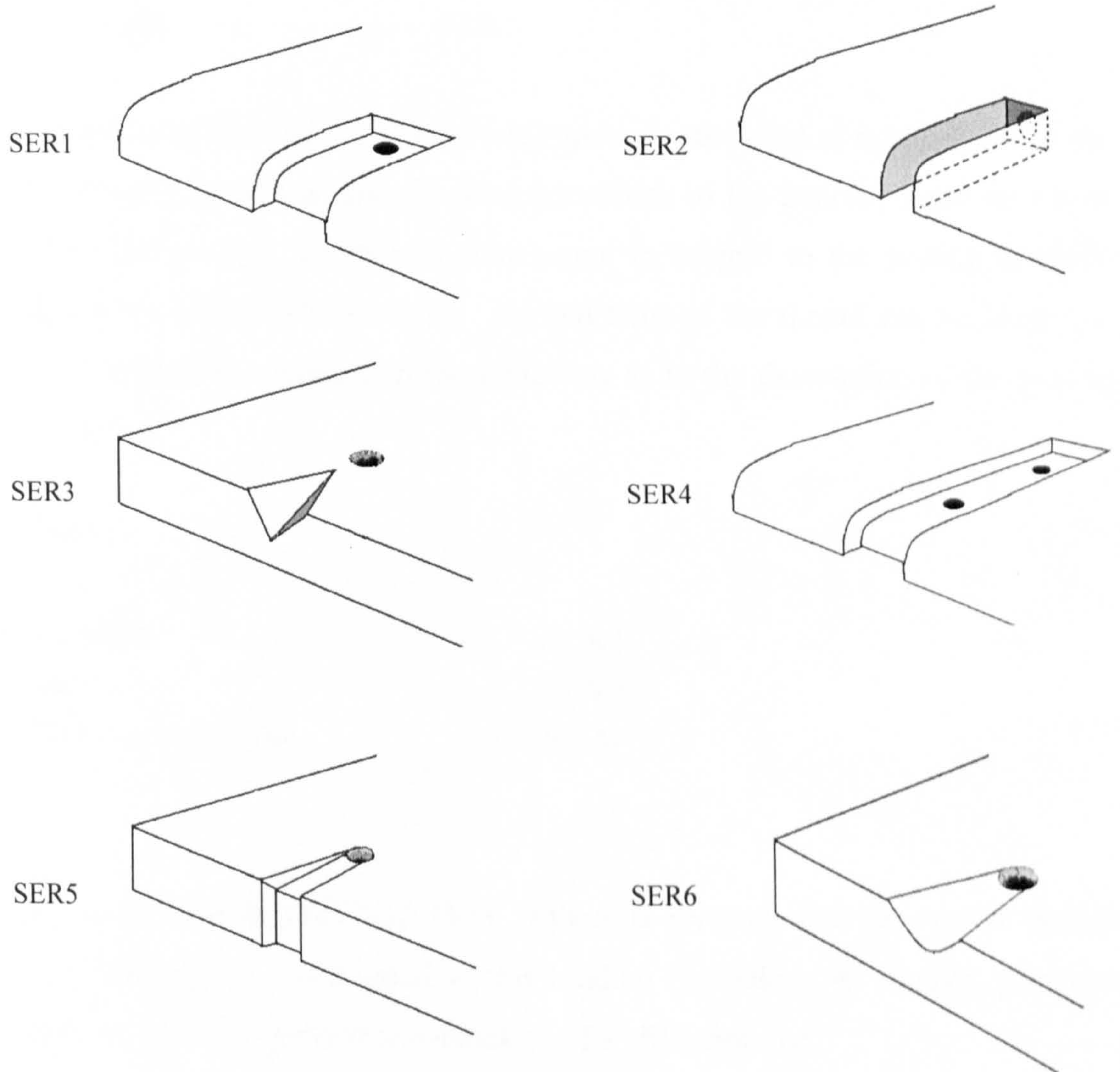

None,  
Not visible (N. V.)

**Board Recesses of Attachment Thread/Supports** [Look-up Field]: indicates the type of recesses, if any, on the boards used to accommodate the thread used for the attachment of the text-block with the boards (in unsupported sewing), in its passage from one attachment hole to the other. In supported sewing, this indicates any additional recesses, different from the spine edge

recesses of attachment thread/sewing supports used to accommodate the ends of the support:

Yes, but not visible,

No,

Chiseled,

Incised,

Not known.

(N. K.)

**Attachment Thread [Look-up Field]:** indicates the kind of thread used for the attachment of an unsupported sewn text-block to the boards, based on visual observation only, either such attachment is integral to the sewing or made through bridling. Whenever the ply and twist of the thread can be identified these should be recorded in the same way as in the description of the sewing thread:

Hemp,

Linen,

Not known

(N. K.)

Not visible

(N. V.)

Same as sewing thread.

(S.a.S)

**Reuse of Boards [Yes/No]:** 'Yes' if there is evidence that the current boards of a binding are not original to this binding but belong to another, previous one, either of the present text-block or of a different one.

**Notes on Boards [Free Text]:** refers to any note concerning boards and their way of attachment that should be recorded although the design of the existing fields of the database don't permit such a thing. These notes could lead to modifications-additions in the database or remain as an individual note for the corresponding books on which it refers.

**SPINE INFORMATION** includes the following fields:

**Spine Shape** [Look-up Field]: indicates the shape of the spine of the bound volume.

Flat,  
Slight round,  
Round,  
Heavy round,  
Deformed/Concave.

**Spine Joints** [Look-up Field]: indicates whether the sewn text-block has a shoulder or ridge where the boards are accommodated or not.

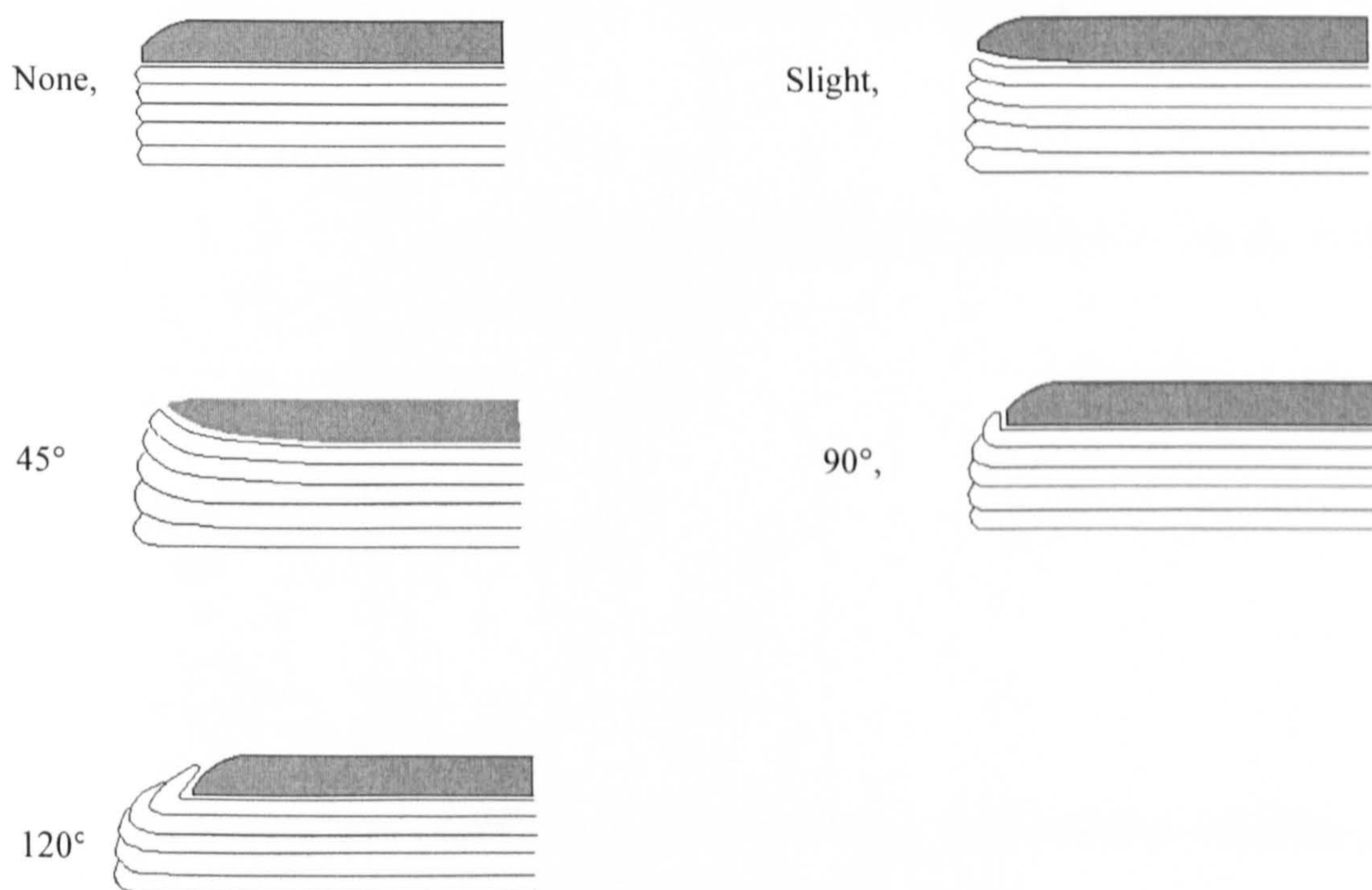

**Spine Lining** [Look-up Field]: indicates if there is any lining in the spine of the book, and if so where, with regard to the sewing stations.

Yes all along the spine,  
Yes between stations (panel lining),  
Yes in head and tail,  
None,  
Not visible

(N. V.)

**Number of Spine Lining Layers [Look-up Field]:** indicates the number of layers of the spine lining:

- 1
- 2
- 3

**Spine Lining Material [Free Text]:** indicates the material used for the lining of the text-block spine. In the case that more than one layers are found they are recorded one after the other, separated with a slash, first layer mentioned first. When discernible the weaving type is recorded based on the descriptions provided by Emery (1994). When canvas is used to describe the lining material it is intended a natural colour hemp or linen textile woven according to the '*balanced plain weave, warp and weft equal in size, spacing and count*' (Emery, 1994, p. 76).

**Spine Lining Thickness [Look-up Field]:** indicates the thickness of the lining on the basis or visual observation:

- Thin,
- Medium,
- Thick,
- Not visible (N. V.)
- Not known (N. K.)

**Spine Lining Adhesive [Look-up Field]:** indicates the adhesive used for adhering the spine lining to the spine if discernible:

- Animal glue,
- Starch paste,
- Other,
- Not known (N. K.)

**Side of Boards Covered [Look-up Field]:** indicates the side of the board where the extensions, if any, of the spine lining are adhered:

None,  
Inside,  
Outside,  
Both sides,  
Not known (N. K.)

**Board Covered [Look-up Field]:** indicates the extension of the spine lining, if any, onto the boards with regard to the total width of the board.

None,  
Whole,  
50%  
30%,  
25%  
10%  
5%,  
Not known (N. K.)  
Not visible (N. V.)

**TEXT-BLOCK EDGE INFORMATION** includes the following fields:

**Trimming Marks [Free Text]:** indicates if there is any trimming marks so that the method and tools used for this process could be deduced.

**Edge Decoration [Look-up Field]:** indicates if there is any decoration in the outer edges of the text-block and if so the type of such decoration.

Marbled,  
Sponge,  
Sprinkled,  
Gauffered,  
Gauffered and gilded,  
Painted, gauffered and gilded,  
Colour washed,  
Gilded,  
Drawn motives,  
Drawn and painted motives,

Painted homogeneously.

**Colour of Edge decoration [Free Text]:** indicates the colour/s of any edge decoration.

**Titling [Free Text]:** indicates if there is any title written on the binding of a book - excluding the common modern paper labels pasted on the spines of manuscripts with the shelf mark and often the title. If so the type is recorded:

No,  
Handwritten,  
Blind tooled,  
Gold tooled.

**Titling position [Free Text]:** indicates where the title is placed on the binding of a book standing vertical:

Spine horizontal (parallel to the head and tail edges of the text-block),  
Spine vertical ,  
Spine oblique,  
Fore-edge,  
Head-edge,  
Tail edge,  
Left board,  
Right board.

**Title [Free Text]:** the text of the title

### **ENDBAND INFORMATION**

**Endband** is a band at the head and tail of a book, sewn through its gatherings and around one or more cores, which usually, regarding the time and the area this research deals with, are anchored on the boards. Though they often are decorated with silk embroidery they are also essential, functional parts of most of the bindings considered and surveyed in the course of the present research. They are further divided into simple and compound endbands. **Simple**



**endbands** are those endbands which normally are the result of a single sewing sequence through the gatherings and around the endband cores. **Compound endbands** are those endbands which are the result of normally two distinct sequences: the endband primary sewing and the endband secondary sewing. The **endband primary sewing** consists of the sewing sequence through which the endband is sewn around one or two cores on the head and tail edges of the book by tying it down through the gatherings. This is essentially the functional part of a compound endband. The **endband secondary sewing** consists of a more or less elaborate sewing, (or weaving), on top of the primary endband, usually<sup>1</sup> not connected or tied-down to the gatherings of the text-block. Therefore its role is mostly, but not always, decorative for which reason normally coloured silk threads and occasionally metal threads are used. Islamic and Armenian endbands are considered here compound though their primary endband, consisting of a warp structure on one core is never found on its own unlike all primary sewing structures in compound endbands which are perfectly functional without the secondary sewing or weaving phase.

In the present research a further variation has been identified in the context of the 'Ivion Scriptorium Atelier' and a single binding from the Sinai Library (see 'Preliminary Endband Sewing' field below), consisting of a sewing through the gatherings and around their head and tail edges without any core incorporated<sup>43</sup>. On top of this **preliminary endband sewing** the primary sewing is made with a thread which instead of being tied-down through the gatherings is anchored on this preliminary endband. This is referred here as a preliminary endband since due to the lack of a core it is structurally weak and could not probably satisfactorily function as a proper endband on its own and furthermore it is never used on its own as a simple endband but always used as a 'base' for a proper endband sewn on cores.

Note that these designations are purely conventional referring only to the functional role of each constituting part or process of an endband and not to the typological entities or the techniques used for each of the different

---

<sup>1</sup> For an exception see the Klimis bindings in section 2.1.4.

<sup>43</sup> See the Ivion Scriptorium bindings in section 3.1.2.

endbands (simple or compound) or sewing phases (preliminary, primary, secondary). For example it is a common thing that simple endbands and primary sewing in compound endbands are technically exactly the same, but differ partly in function. So we can find a Greek 2-cores endband used either as a simple endband or as a primary sewing of a compound endband. In the latter case its function is slightly different since it is not only acting structurally in order to reinforce the connection between the text-block and the boards but also acts as a basis on which the secondary sewing is made.

By **endband cores** are intended the distinct underlying structural units of an endband (that however can be simple or made by more than one single units of thread or other material) that serve as cradles or bases on which an endband is sewn. For endbands consisting of more than one cores, first, second, third etc. core indicates the relative position of each core in respect to its position on the top and bottom edges of the text-block, the first core being the one which is placed on top of the text-block in direct contact with it, the second core being the one placed above the first etc.

For compound endbands consisting of more than one overlapping cores, the first core, and often also the second one, is the one on which the primary endband sewing is made, while the third is always (at least in the context of the present research) a constitutional part of the secondary embroidery.

This section includes the following fields:

**Kind of endband [Look-up Field]:** indicates if the endband is a simple or compound endband

Simple,  
Compound.

**Number of Cores [Free Text]:** indicates the total number of the cores used for the endbands.

**First Core Material [Look-up Field]:** indicates the material of the first core and any relevant information concerning its make-up, for example if flat, vertical, horizontal, or rolled. The ply and twist of any cord or thread,

whenever discernible are also recorded in the same way as in the corresponding fields of the sewing thread. Such further specifications will follow one of the options listed below:

- Missing,
- Not known , (N. K.)
- None,
- Cord,
- Leather,
- Paper,
- Parchment,
- Textile,
- Spine lining extension..

**First Core Thickness [Look-up Field]:** indicates the thickness of the core established by visual observation only

- Thin,
- Medium,
- Thick,
- Not known. (N. K.)

**Second Core Material[Look-up Field]:** indicates the material of the second core and any relevant information concerning its make-up, for example if flat, vertical, horizontal, or rolled. The ply and twist of any cord or thread, whenever discernible are also recorded in the same way as in the corresponding fields of the sewing thread. Such further specifications will follow one of the options listed below:

- Missing,
- Not known (N. K.)
- None,
- Cord,
- Thread,
- Leather,
- Paper,
- Parchment,

Textile.

**Second Core Thickness [Look-up Field]:** indicates the thickness of the core established only by visual observation:

Thin,

Medium,

Thick,

Not known.

(N. K.)

**Third Core Material [Look-up Field]:** indicates the material of the third core.

Whenever the ply and twist of a thread or cord is discernible it is recorded here following one of the options listed below:

Missing,

Not known,

None,

Cord,

Thread.

(N. K.)

**Third Core Thickness [Look-up Field]:** indicates the thickness of the core established on visual observation only.

Thin,

Not known.

(N. K.)

**Projection onto Boards [Yes/No]:** Yes if the endband projects onto the boards.

**Distance of Projection [Free Text]:** indicates the actual distance of projection of the cores onto the boards recorded in millimeters. This measure is followed by the percentage between brackets of the boards width that such distance occupies. This percentage is also included in order, if possible, to find out if the distance of projection is related to the format of the book or not.

**Endband Anchoring / Attachment System** [Look-up Field]: indicates the type of anchorage or attachment of the endband or its core/s on the boards. When extra small recesses were made on the board's edges to accommodate the tie-down thread like the ones shown in drawing then 'extra accommodation' is recorded followed by 'Int' when on the inner face and 'Ext' when on the external face:

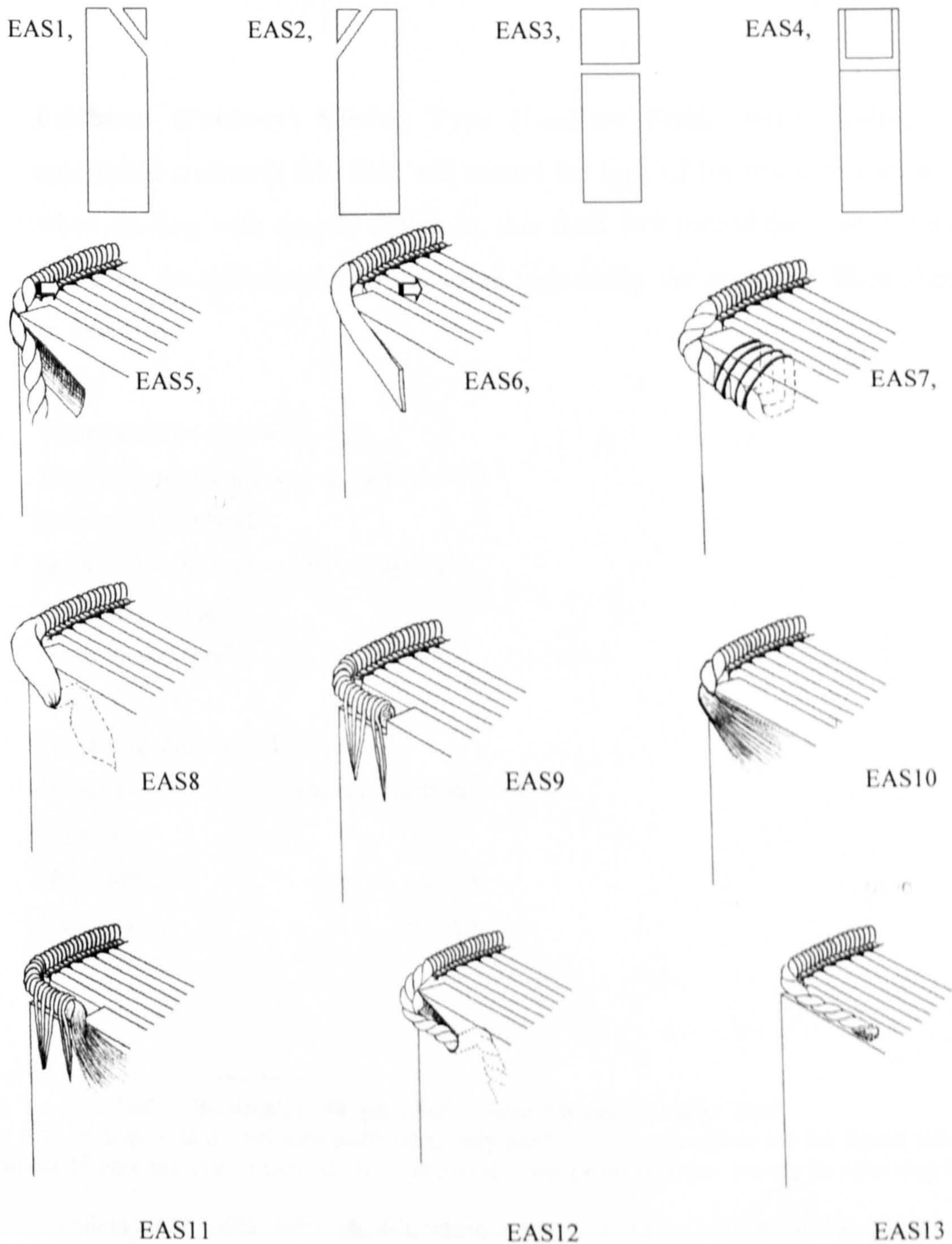

Not known

(N. K.)

Not visible

(N. V.)

**Preliminary Endband Sewing [Look-up Filed]:** it indicates any preliminary sewing for the endbands. So far two variations have been recorded:

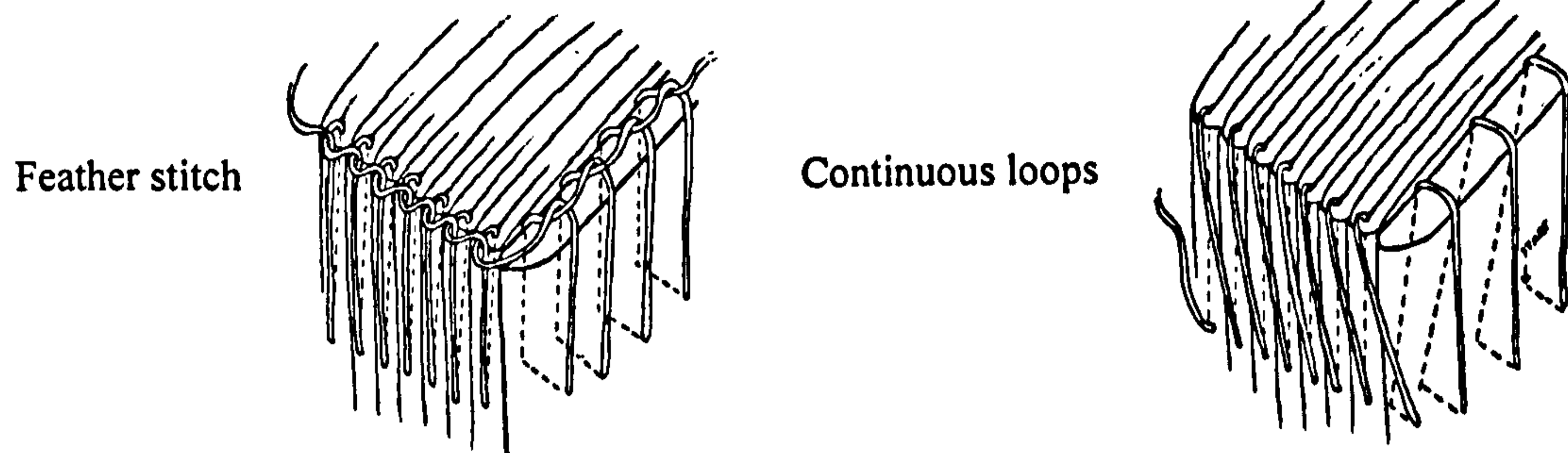

**Endband (Primary) Sewing Type [Look-up Field]:** when dealing with compound endbands this field will record the type of the primary sewing, but when dealing with simple endbands, this field will record the type of simple endband. As said above they are often technically the same but differ slightly in function.

- Wound plain on one core<sup>48</sup>,
- Wound/sewn in some way on the first core<sup>2</sup>
- Sewn with front bead<sup>49</sup>,
- Sewn with front bead and crowning core<sup>50</sup>,
- Greek single core<sup>51</sup>,
- Greek double core<sup>52</sup>,
- Warps<sup>53</sup>,
- No sewing, only spine lining rolled,
- No sewing, only spine lining rolled around core,
- Missing,
- Not visible, (N. V.)
- Not known . (N. K.)

<sup>48</sup> See 'Le Tranchefiles Brodées', 1989, pp. 28-29, where it is designated as 'Bati'.

<sup>2</sup> This is to indicate that the primary endband is only partly visible, enough to see the thread wounded around the 1<sup>st</sup> core but due to limited visual access it is not possible to say exactly in what way this is done.

<sup>49</sup> See Greenfield and J. Hille, 1990, pp. 4-8, where it is designated as 'Headband with a bead on the edge'.

<sup>50</sup> See Greenfield and J. Hille, 1990, pp. 21-26, where it is designated as 'French double headband'.

<sup>51</sup> See 'Les Tranchefiles Brodées' 1989, model No 17.

<sup>52</sup> See 'Les Tranchefiles Brodées', 1989, model 19 and J. Greenfield & J. Hille, 1990, pp. 51-56.

<sup>53</sup> See 'Les Tranchefiles Brodées', 1989, pp. 86, where it is designated as 'Bati de la tranchefile Arabe' and Greenfield and J. Hille, 1990, pp. 65-66, steps 1-3.

**Endband (Primary) Sewing Thread(s) and Colour(s)[Look-up Field]:** indicates the kind of thread(s) used for the construction of the endband primary sewing established on visual observation only, and its colours().

Linen,  
Hemp,  
Cotton,  
Silk,  
Same as the sewing thread, ( S.a.S),  
Not known. (N. K.)

**Endband (Primary) Sewing Thread(s) Thickness [Look-up Field]:** indicates the relative fineness of the thread/s used for the primary endband, based on visual observation.

Thin,  
Medium,  
Thick.

**Endband (Primary) Sewing Thread(s) Ply [Look-up Field]:** indicates the pattern of endband primary sewing thread ply.

S,  
Z,  
I,  
Not known. (N. K.)

**Endband (Primary) Sewing Thread(s) Twist [Look-up Field]:** indicates the twist of the thread used for the endband primary sewing. See also 'Sewing thread tightness'.

Tight,  
Medium,  
Loose,  
Not known (N. K.)

**Tie-downs Anchorage [Look-up Field]:** indicates the placement of the hole of the endband (primary) sewing tie-downs on the spine fold of the gatherings with respect to the change-over sewing stations. The terms 'outside' and 'inside' refer to the placement of the change-over stations in the spine of the gatherings, 'outside' meaning beyond the change-over stations toward the head and tail edges, and 'inside' meaning between the change-over stations and the main sewing stations.

Uses change-over sewing stations,

Uses separate passing hole outside change-over stations,

Uses separate passing hole inside change-over stations,

No tie-downs,

No tie-downs, sewn on the spine lining.

**Number of Tie-downs [Look-up Field]:** indicates the relative number of tie-downs in respect to the number of the gatherings of the text-block. Whenever the actual number of tie-downs is visible this should be recorded. It will normally record one of the following options:

Every gathering,

Frequent,

Infrequent,

Not known, (N. K.)

Not visible. (N. V.)

**Position of the Tie-downs [Look-up Field]:** indicates the position of the endband tie-downs in respect to the gatherings of the text-block.

Centre-fold,

Random.

**Endband Secondary Sewing or Weaving Type [look-up Filed]:** it refers to compound endbands and indicates the type of the secondary sewing (or weaving):



Greek double core,<sup>56</sup>  
 Islamic,  
 Islamic over single warps,<sup>57</sup>  
 Islamic over double warps,  
 Chevron,<sup>58</sup>  
 Chevron crowning core,<sup>59</sup>  
 Embroidered two colours, front bead,<sup>60</sup>  
 Embroidered two colours, crowning core,<sup>61</sup>  
 Embroidered two colours, front bead & crowning core,<sup>62</sup>  
 Cretan,  
 Cretan over single warps,<sup>63</sup>  
 Cretan over double warps,  
 Iviron 3,<sup>64</sup>  
 Armenian,<sup>65</sup>  
 Armenian over single warps.

**Endband Secondary Sewing or Weaving Thread(s) and Colour(s) [Look-up Field]:** indicates the type and colour of thread(s) used for the endband secondary sewing or weaving established only by visual observation, and its colours.

Silk,  
 Silk & metal thread,  
 Cotton,  
 Linen,

---

<sup>56</sup> This is the typical Greek 2-core endband with the difference that it is worked above a preliminary endband and therefore considered as a secondary endbands. See the Iviron scriptorium bindings in section 3.1.2.

<sup>57</sup> This is the typical Islamic, woven, endband. See Greenfield and Hille, 1990, pp. 65-68.

<sup>58</sup> See Greenfield and Hille, 1990, pp. 83-85, where it is called 'Renaissance chevron headband' and 'Les Tranchefiles Brodées', 1989, models No 9 where it is called "Tranchefile brodée a chevrons".

<sup>59</sup> See 'Les Tranchefiles Brodées', 1989, models No 20, where it is called also 'Tranchefile Grecque'.

<sup>60</sup> See above, note 49.

<sup>61</sup> This is a type of endband which should structurally be identified with the 'Sewn two colours, front bead and crowning core' endband with the difference that the front bead is practically unnoticeable in either of the two faces of the endband.

<sup>62</sup> See above, note 50.

<sup>63</sup> This is a woven endband based on the same technical principles of the Islamic endband. The designation Cretan refers to specific colour combination, green red, and white, almost constantly encountered on Cretan bindings of the late fifteenth – sixteenth centuries. See the Cretan bindings in section 2.1.2.

<sup>64</sup> A type of woven endband encountered on bindings of the Iviron monastery of the late seventeenth – early eighteenth centuries. See the Cosmas Macedon bindings in section 3.2.4.

<sup>65</sup> See 'Les Tranchefiles Brodées', 1989, models No 26, 29, designated also as 'Tranchefile Arménienne'.

Metal thread.

**Endband Secondary Sewing or Weaving Thread(s) Thickness:** indicates the thickness of the thread(s) used for the endband secondary sewing (weaving) based only on visual observation.

Thin,  
Medium,  
Thick.

**Endband Secondary Sewing (Weaving) Thread(s) Ply [Look-up Field]:** indicates the ply of endband secondary sewing (weaving) thread(s). Information whenever possible should be recorded in the same way as described in "Sewing Thread Ply" field.

S,  
Z,  
I,  
Not known (N. K.)

**Endband Secondary Sewing (Weaving) Thread(s) Twist [Look-up Field]:** indicates the twist of the thread(s) used for the endband secondary sewing/weaving.

Tight,  
Medium,  
Loose,  
Not known (N. K.)

**Endband Secondary Sewing (Weaving) Metal Thread Type [Look-up Field]:** indicates the type of any metal thread used for the endband secondary embroidery (weaving).

Silver around silk thread,  
Gold around silk thread,  
Unknown metal around silk

Not known.

(N. K.)

**Marker(s)** [Look-up Field]: indicates the presence or not of any marker/s found in the book and structurally connected with it. **Simple** markers are intended those markers which consist of one single part, while **compound** markers are those markers which consist of two distinct parts connected one to the other.

No,

Simple

Compound,

Missing,

Not known.

(N. K.)

**Kind of Marker(s)** [Look-up Filed]: this field serves as a general statement about the kind of markers found on the book. Three kinds have been recognized in the context of the present research of which the first two can only be simple markers, whilst the third one can be either in the form of a simple or compound marker:

Leaf tab markers (A),

Board tab markers on one board (B),

Board tab markers on both boards,

Endband string markers (C).

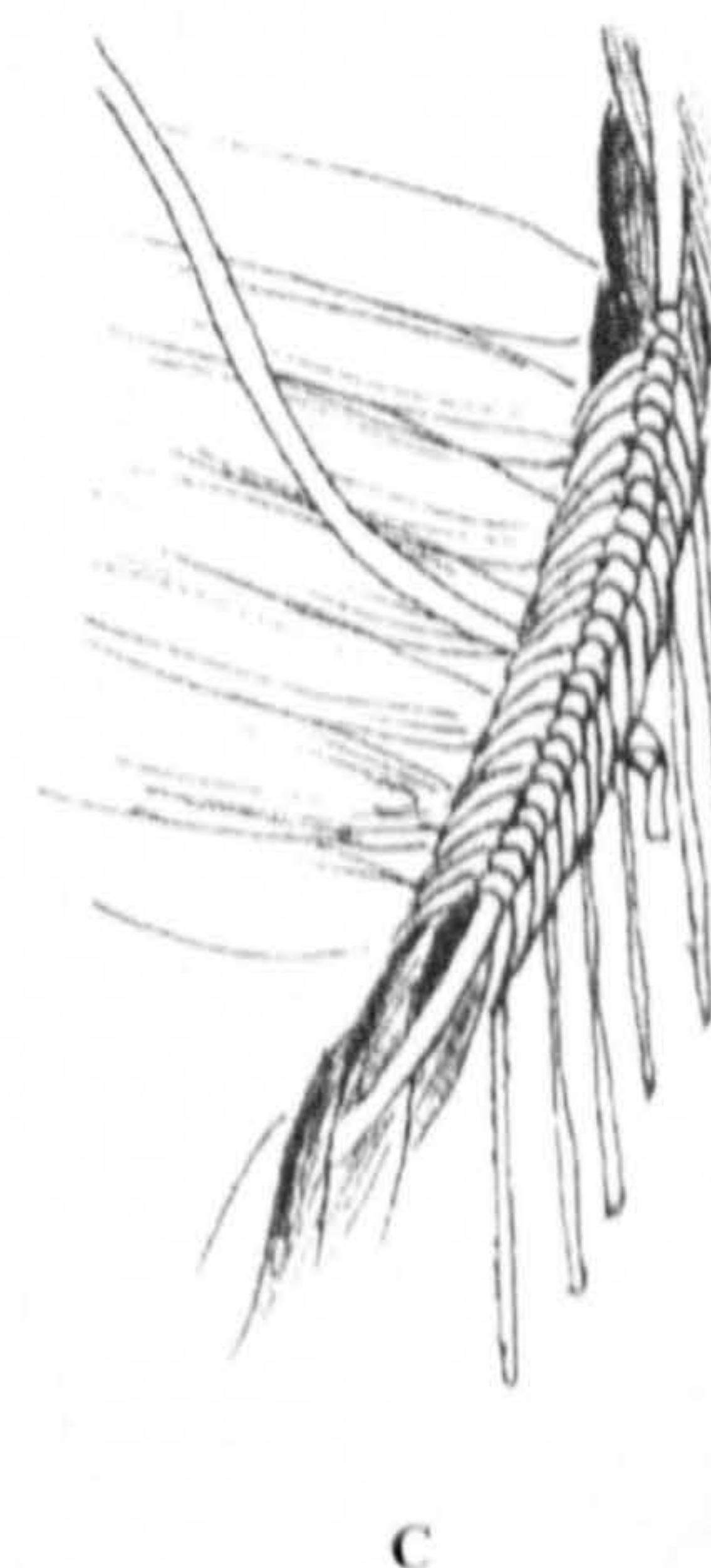
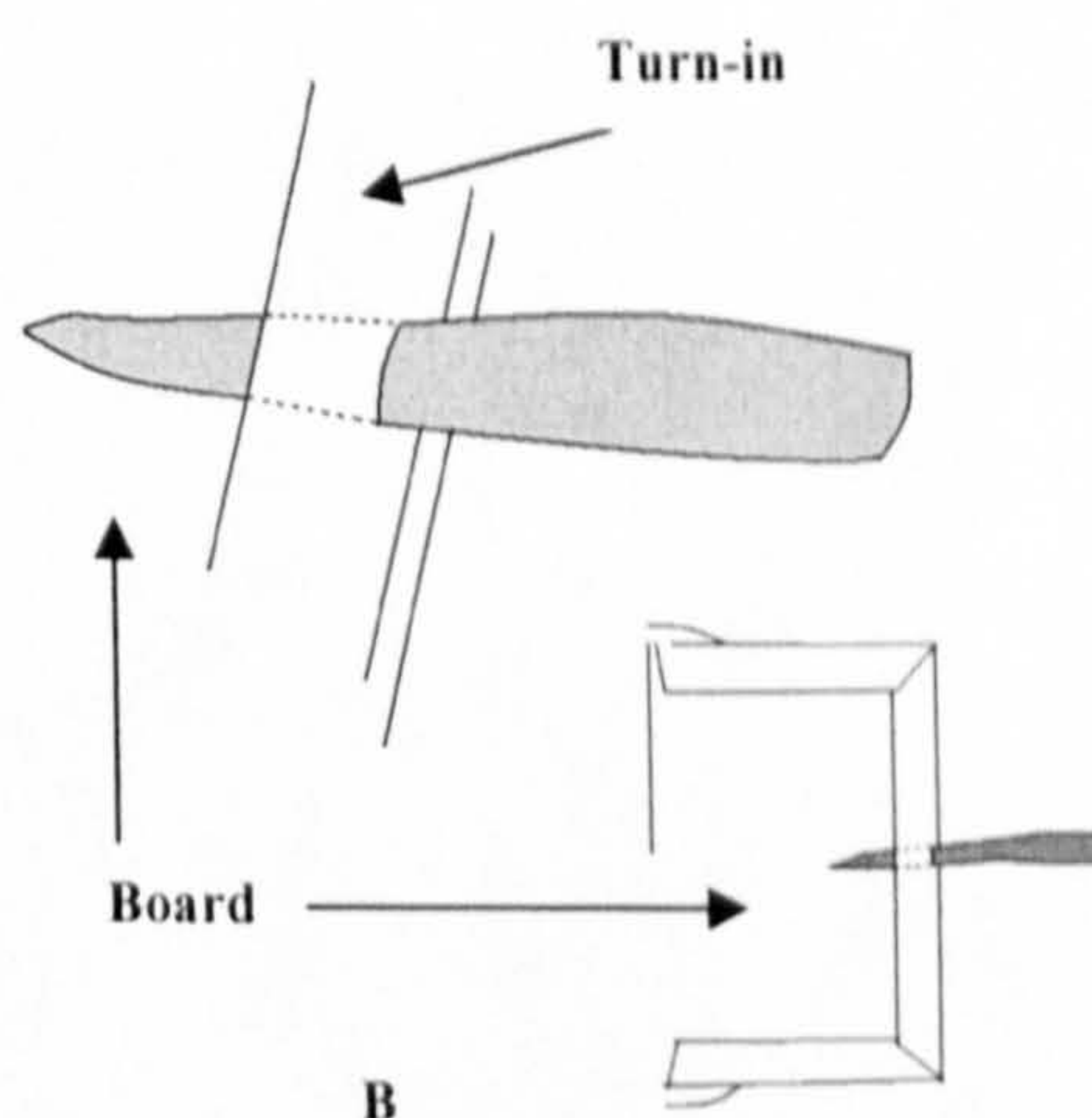
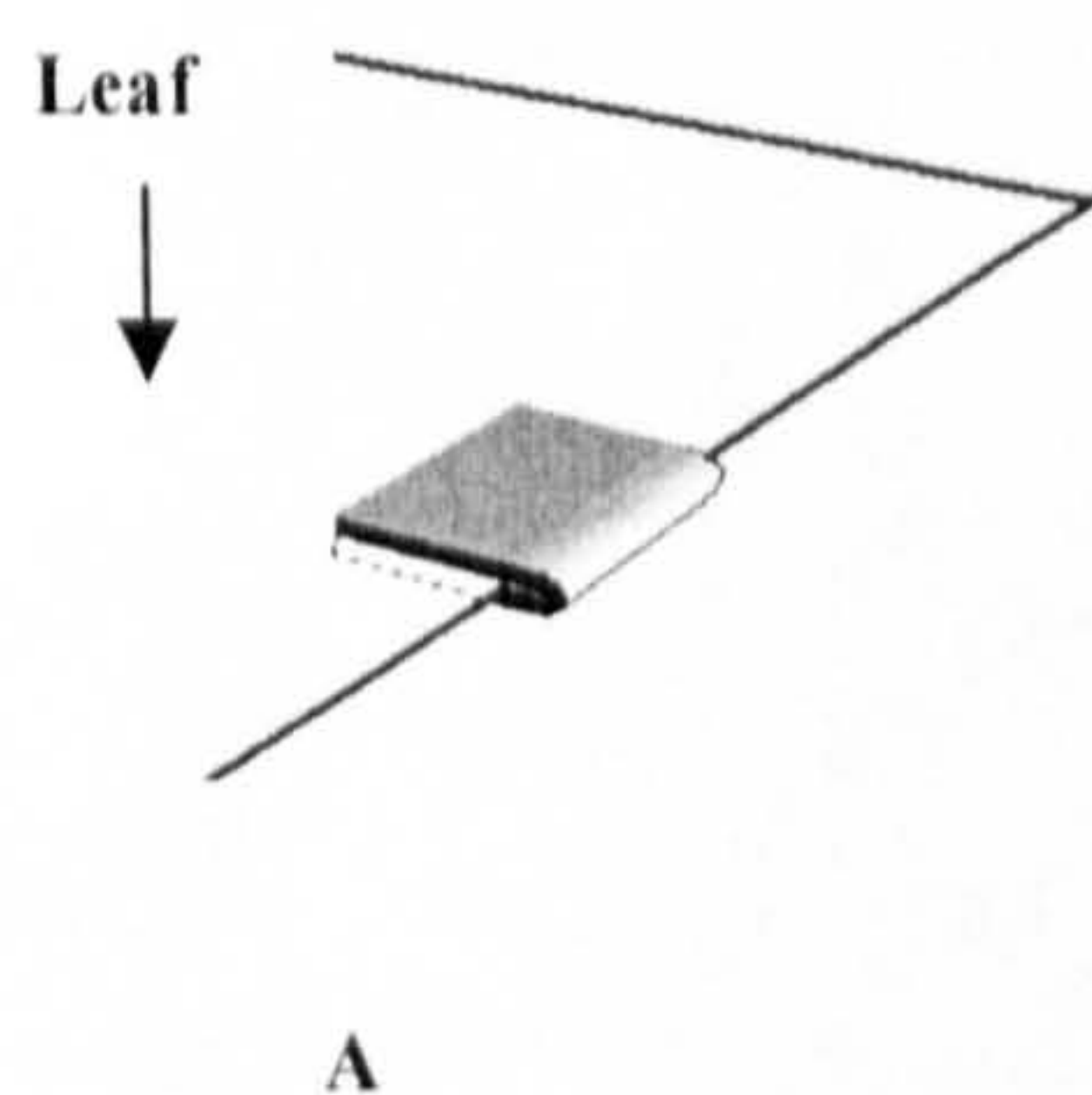

**Simple Markers Type and Number** [Look-up Field]: indicates the type of the simple markers, if any, and their number:

Single-colour thread string,  
 Two-colour thread string,  
 Multiple-colour thread String,  
 Multiple-colour braided strings,  
 Textile ribbon,  
 Single leather tab,  
 Folded leather tab (drawing A in previous field).

**Simple Marker Material and Colour** [Free text]: will indicate the material and the colour of the simple markers, e.g. red goat leather, yellow and red silk etc. S.a.E. indicated that the thread used is the same as the one used for the endband primary or secondary sewing (S.a.P.E. and S.a.S.E. respectively).

**Simple marker way of Attachment** [Look-up Field]: indicates the way in which the simple markers are attached to the endband, the text-block leaves, or the boards according to the type.

Inserted through slit and pasted (for board tab markers),	ItSp
Inserted through slit and nailed,(for board tab markers),	ItSn
Inserted through slit pasted and nailed (for board tab markers),	ItSpn
Folded and pasted on both sides of leaf (for leaf tab markers),	FpbsL
Pasted on one side of leaf (for leaf tab markers),	PosL
Fastened on headband A (A),	FH(a)
Fastened on headband B (B),	FH(b)
Fastened on headband C (C),	FH(c)
Fastened on headband D (D),	FH(d)
Fastened on headband E (E).	FH(e)

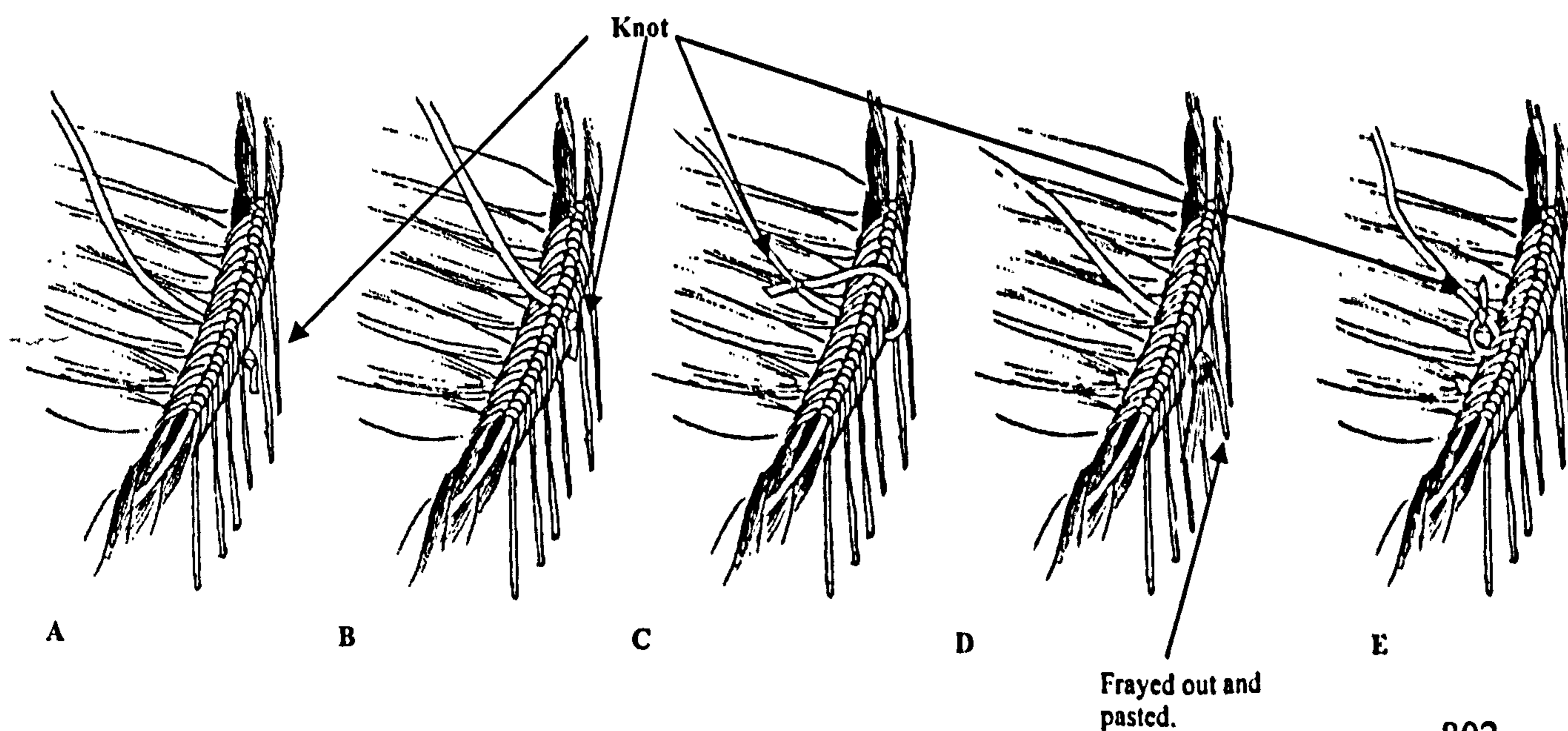

**Primary Marker Type and Number [Look-up Field]:** indicates the type and the number of the primary marker in compound markers. ‘Simple’ is to indicate loops consisting of one or multicoloured thread lengths normally plied together, and ‘Compound’ to indicate that loops consist of two different parts, one core consisting of thread lengths or cord which is consecutively covered with a thread, normally silk, either feather stitched or just wrapped around it. The following variations have been recorded:

- Simple open loop (A),
- Simple closed loop (B),
- Simple kinked open loop (C),
- Simple kinked closed loop (D),
- Simple plaited open loop,
- Compound open loop feather stitched,
- Compound open loop wrapped,
- Compound closed loop feather stitched (E),
- Compound closed loop wrapped (F),
- Compound closed loop shape-of-eight (G).

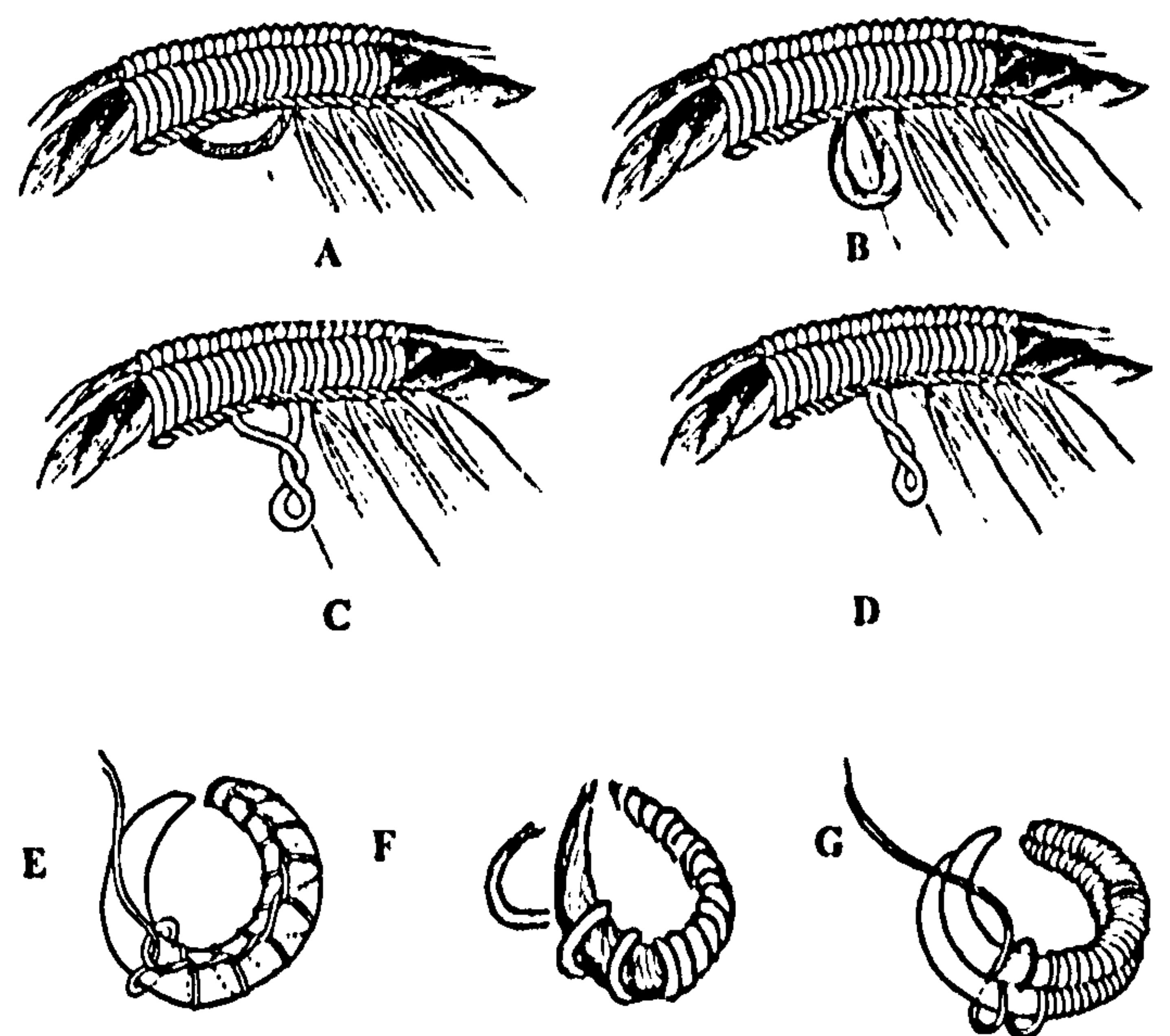

**Primary Marker Material and Colour/s [Free Text]:** indicates the material used for the construction of the markers and their colour. S.a.E. indicated that the thread used is the same as the one used for the endband primary or secondary sewing (S.a.P.E. and S.a.S.E. respectively)

**Primary Marker Place & Way of Attachment [Free text]** indicates the place and the way that the primary marker in compound markers is fastened to the headband. The following variations have been recorded:

- Laced through the base of the headband front and back alternatively, both ends knotted A (A), LtH(a)
- Laced through the base of the headband, frayed and pasted B (B), LtH(b)
- Laced through the base of the headband, ends knotted together (C), LtH(c)

Laced through the base of the headband, both ends knotted (D)	LtH(d)
Laced through the two cores of the headband, both ends knotted (E),	LtH(e)
Laced through the endband secondary sewing (F).	LtH(f)
Laced through the base of the headband, but unclear how ends are fastened (G)	LtH(g)
Not know.	(N.K.)

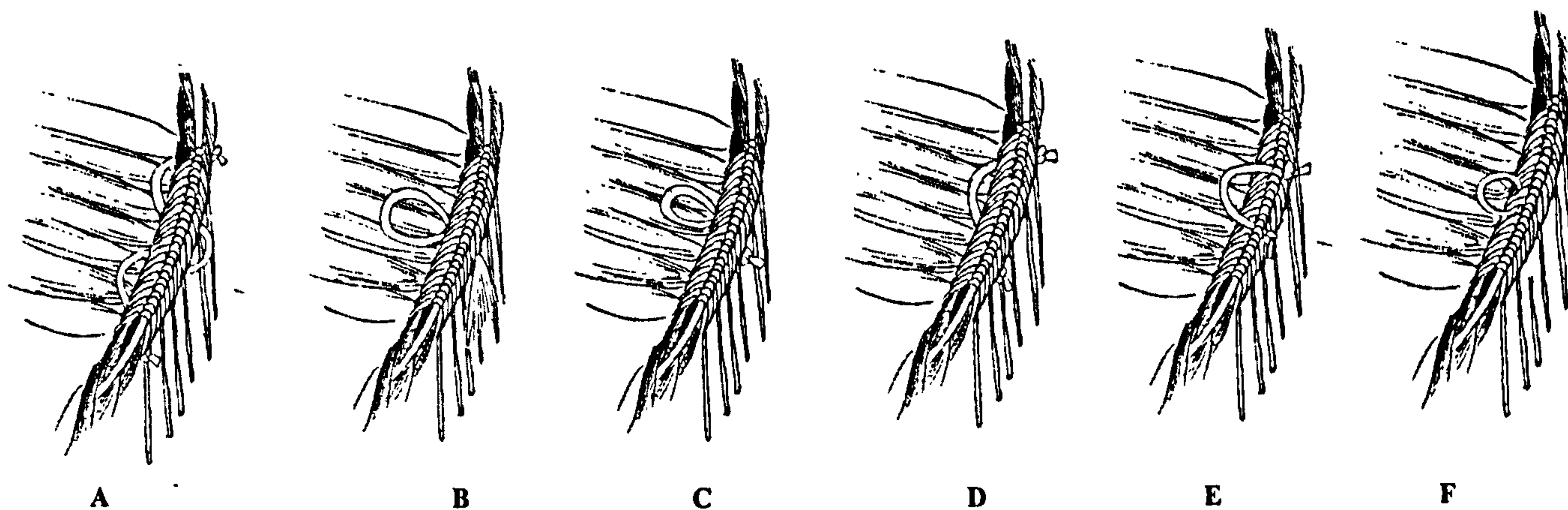

**Secondary Marker Type and Number[Free Text]:** Indicates the type and the number of the of the secondary marker. The following variations have been recorded:

- Single-colour thread string,
- Two-colour thread string,
- Multi-colour thread string,
- Cord string,
- Textile ribbon.

**Secondary Marker Material and colour/s [Free Text]:** Indicates the material and colour/s of the secondary marker.

**Secondary marker way of attachment [Look-up Field]:** indicates the way the secondary marker in compound markers is fastened to the primary marker:

Knotted in the middle (A),	KiM
Knotted in the end (B),	KiE
Looped (C),	L
Sewn (D),	S
Plaited (E),	Pla
Plied (F).	Pli

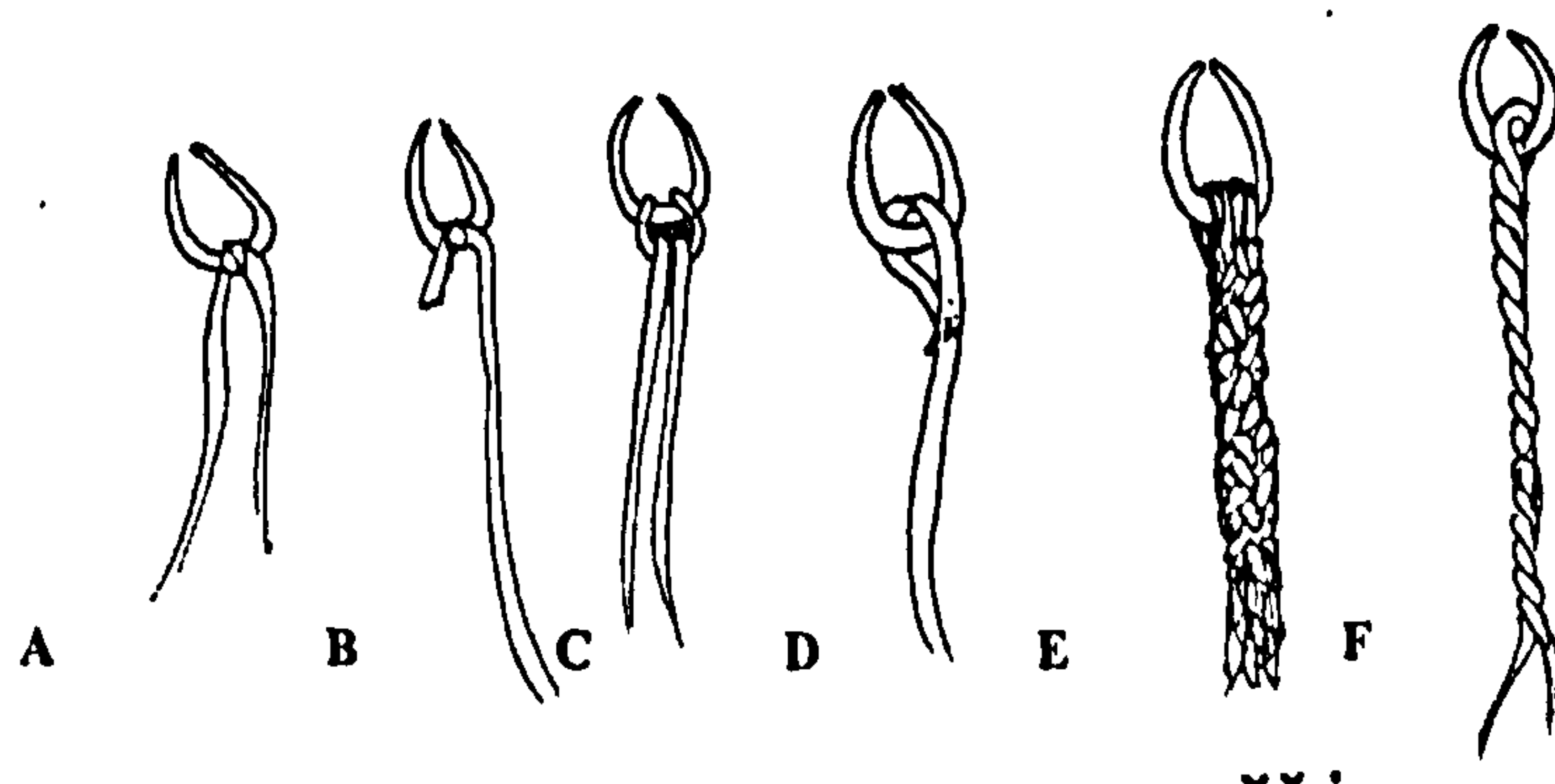

**COVER INFORMATION** includes the following fields:

**Cover Material [Look-up Field]:** indicates the material used for the cover of the bound volume.

None,  
Missing,  
Tanned leather,  
Tawed skin,  
Parchment,  
Paper,  
Silk textile,  
Silk velvet,  
Marbled paper,  
Parchment Ms waste,  
Parchment Ms waste & leather,  
Marbled paper over leather,  
Reused gold tooled tanned leather,  
Reused blind tooled tanned leather,  
Reused tanned leather.

**Cover Material source [Look-up Field]:** indicates the animal species from which the leather of the cover is made on the basis of visual observation only. It should be noted that the distinction by visual observation only is more often than not quite difficult and uncertain, especially between sheep, hairsheep and goat:

Goat,  
Sheep,  
Hairsheep,  
Calf,  
Not known. (N. K.)

**Cover Type[Look-up Field]:** Indicates the type of the cover.

None,  
Missing,  
Full,

Full with extending endcaps.<sup>66</sup>

**Cover Quality [Look-up Field]:** gives a general statement about the quality of the cover. This field will record its original quality whenever the state of preservation does not compromise such evaluation, in which case a general statement on the preservation is recorded between brackets:

Bad,  
Normal,  
Fine,  
Badly preserved,  
Superficial dirt and grime,  
Flaked,  
Abraded.

**Cover Colour [Free Text]:** indicates the colour of the cover. Whenever there is a clear difference of the covers colour in exposed to light and protected areas (such as the turn-ins), then the colour of the leather as seen in these protected areas is recorded as obviously closer to the original one.

**Adhesive [Look-up Field]:** indicates the adhesive used for the attachment of the cover on the boards, if this is discernible.

Animal glue,  
Starch paste,  
Not known (N. K.)

**Cover Thickness [Look-up Field]:** indicates the relative thickness of the cover as this can be seen for example in the turn-ins.

Thin,  
Medium,  
Thick,  
Not known (N. K.)

---

<sup>66</sup> This is a common feature of Islamic bindings and of post-Byzantine bindings imitating Islamic structures. Refers to small extensions of the leather cover protruding from the spine toward the endbands, meant to protect them from attrition.



**Spine Treatment [Look-up Field]:** indicates the treatment of the cover in the spine area:

Tight-back,  
Hollow-back,  
Sewn together with text-block.

**Turn-ins Type [Look-up Field]:** indicates the type or form of the turn-ins of the cover

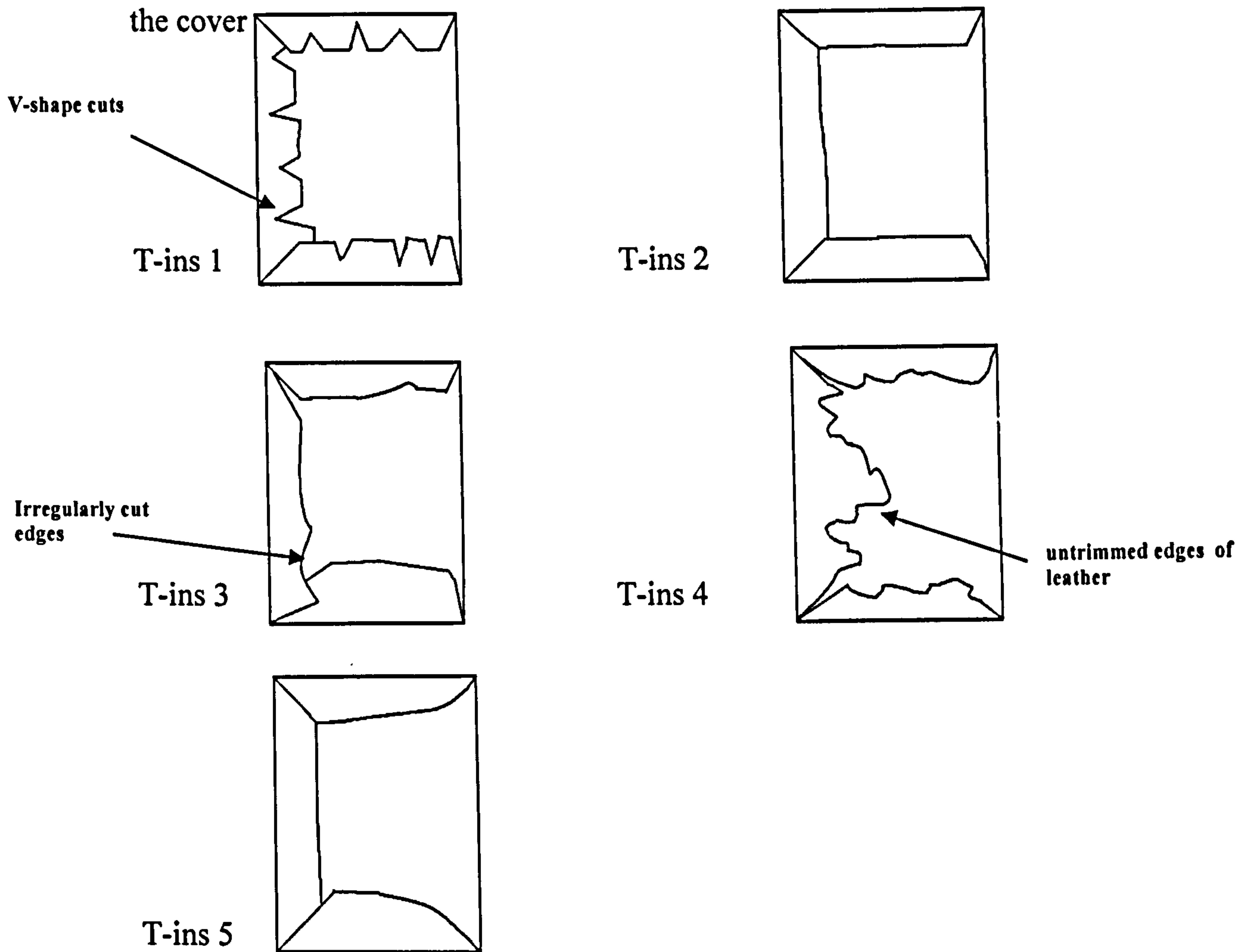

**Turn-ins Width [Look-up Field]:** indicates the relative width of the turn-ins.

Medium,  
Narrow,  
Extra Narrow,  
Wide,  
Varies,

Not known.

(N. K.)

**Turn-ins Cut [Look-up Field]:** indicates the time of execution of the cover's turn-ins trimming in respect to the actual process of covering the book. Whenever such a trimming is made after adhering the cover on the boards, normally there should be marks left from the trimming on the inner side of the boards.

Before covering,

After covering,

Not known

(N. K.)

**Corners Mitering Type [Look-up Field]:** indicates the form of the corners of the cover's turn-ins. If more than two different types are encountered, then "varies" should be recorded.

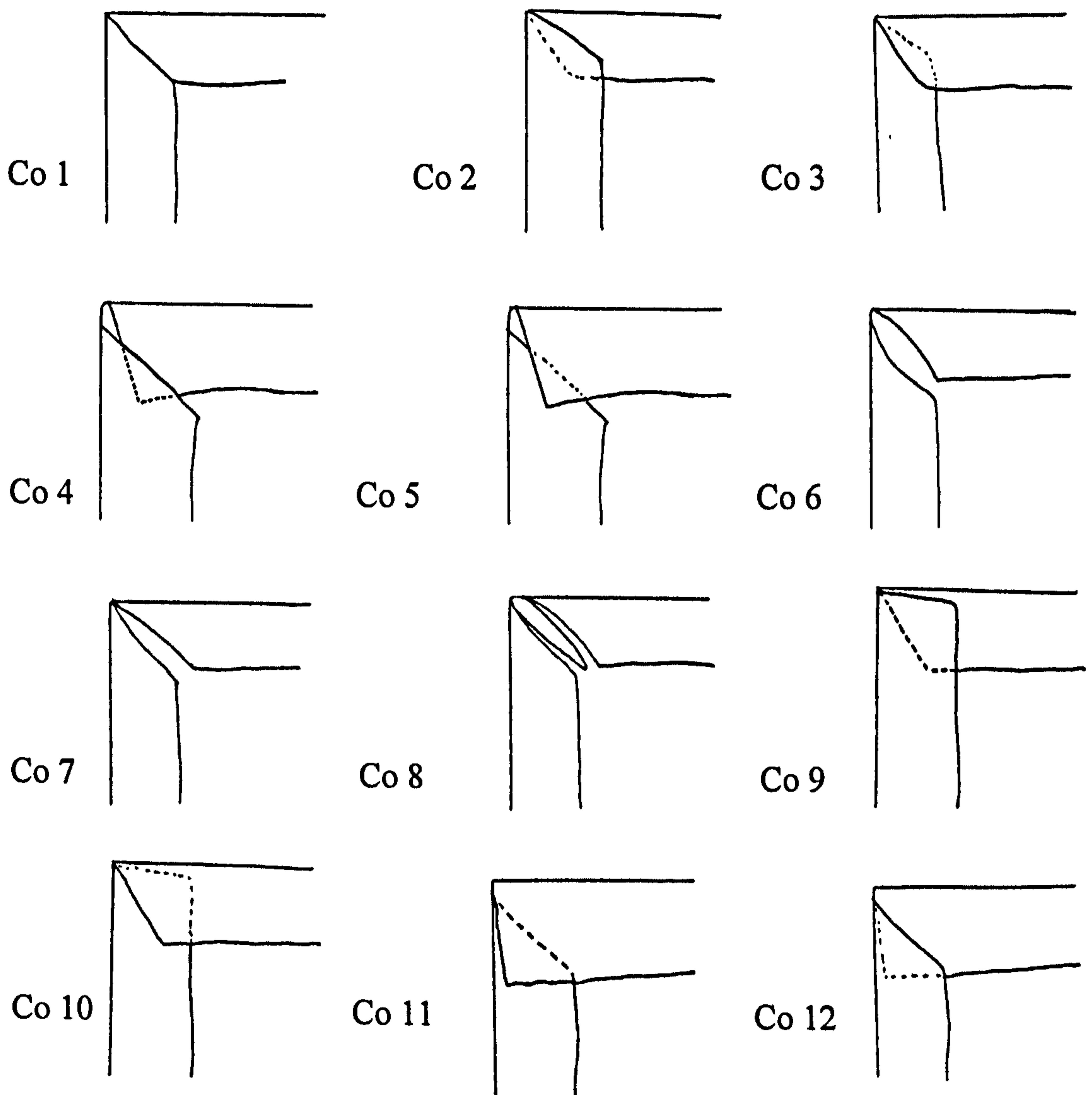

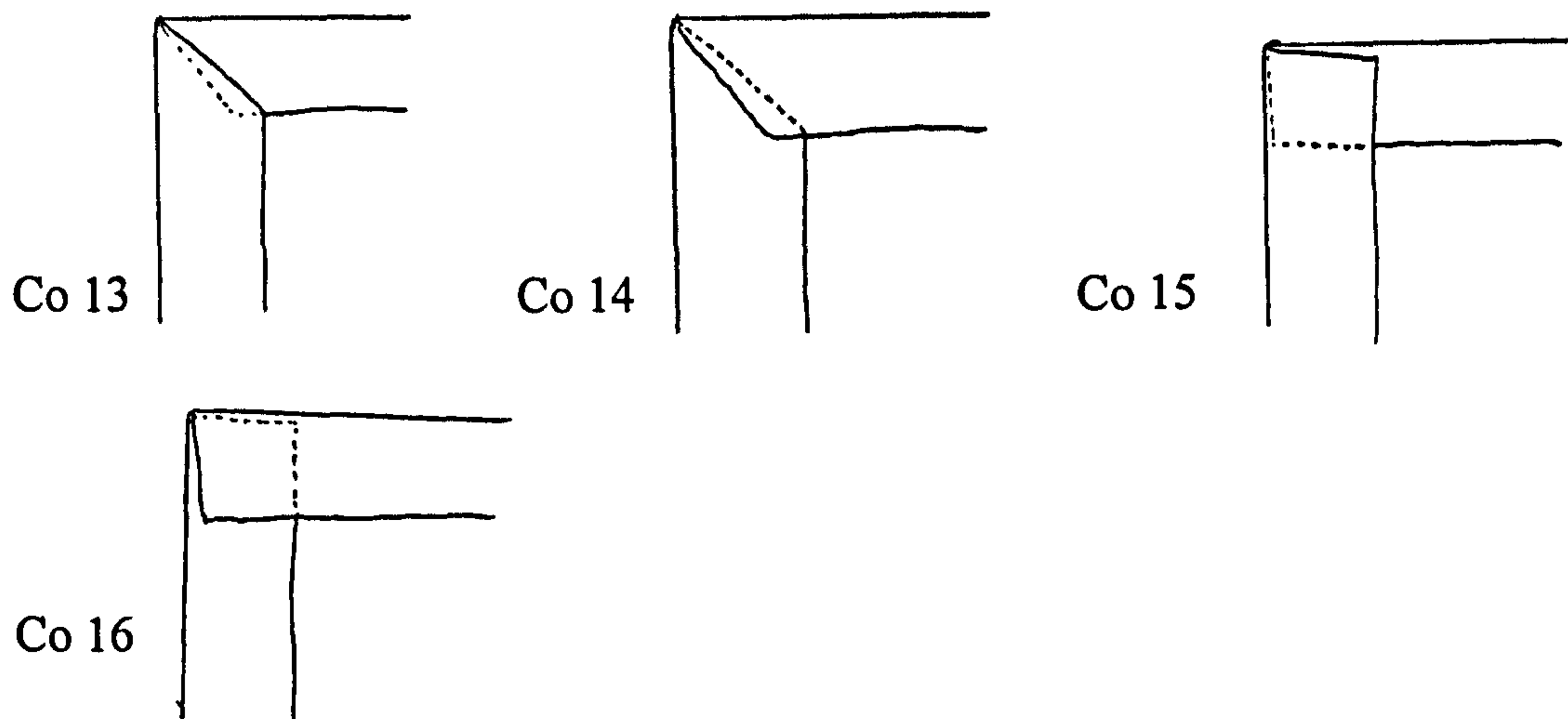

**Edge tongue extensions [Look-up Field]:** indicates the presence and arrangement of any tongue-like extensions of the leather cover in the corners of the boards edges which can be pasted underneath or above the cover in order to facilitate the attachment and the turning-in of the cover in bindings with thick boards. 'External' indicate that the extensions are pasted above the cover, while 'internal' indicates that they are pasted underneath the cover:

- No,
- From fore-edge to head and tail edges, external,
- From head and tail edges to fore-edge, external,
- From fore-edge to head and tail edges, internal,
- From head and tail edges, internal,
- Mixed, external,
- Mixed internal,
- Not known.

(N. K.)

**Tongue extension**

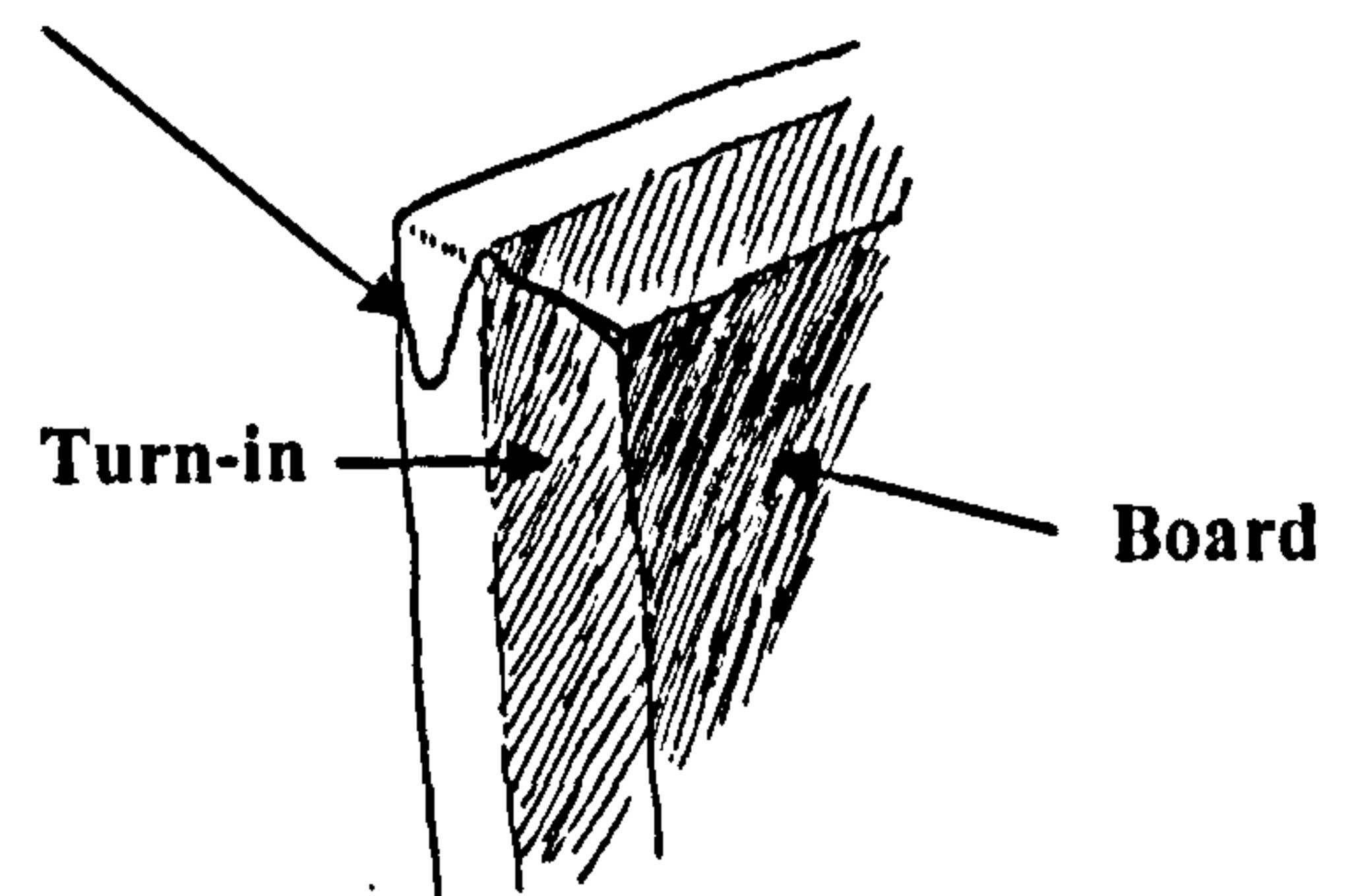

**Decoration [Yes/No]:** Yes if the cover of the binding has any kind of decoration.

**Decoration Type [Look-up Field]:** indicates the technique of execution of the decoration.

- Blind tooled,
- Gold tooled,
- Blind & gold tooled,

Painted,

Painted & blind tooled.

**Decorative pattern:** refers to a standardized typology of the decoration layout of bindings covered in leather or in parchment. The classification is based on the general decoration “grid” normally made with fillets (or occasionally creasers) on the cover of the boards. On this basic ‘grid’ tools can be arranged in a variety of ways, which could not be consistently codified. The only exception is represented by the pattern ‘Dec 15’ which consists represents a pattern with a centerpiece and similar corner-piece tools, which became very popular in the Balkans from the seventeenth century onward (see the Cosmas Macedon bindings in section 3.2.4.). Such arrangement of the tools of the cover surface can be either of the typical ‘Islamic’ type consisting of a big centre-piece and four similar corner-pieces, or can consist of smaller tools arranged as to give the impression of one centre-piece (see for example the binding of S. A. 676 in the New Library bindings in section 2.3.2.). Each classified pattern has two or more variations (named with the letters a, b, c, etc) according to the number of frames. The frames may consist of rolls impressions, repeated impressions of small multi-use tools or may just be outlined with fillets and the space between the fillets left empty or filled with occasional impressions of tools.

There are decorative patterns, which are more complicated than those classified but which, nevertheless, can often be considered as combinations of the patterns catalogued below. In these occasions all patterns involved are mentioned starting from the outer pattern and continuing to the inner one. In some cases patterns can be categorized under two different patterns and in such occasions the simplest way should be chosen. When different decorative patterns are used for the two boards this should be recorded with the letters ‘L’ (Left) or ‘R’ (Right) following the codified designation. The patterns listed below could satisfactorily describe the decoration of the great majority of the bindings surveyed in this research. In those few, isolated, cases where decoration could not be described by the patterns listed below ‘other’ is recorded.

DEC 1

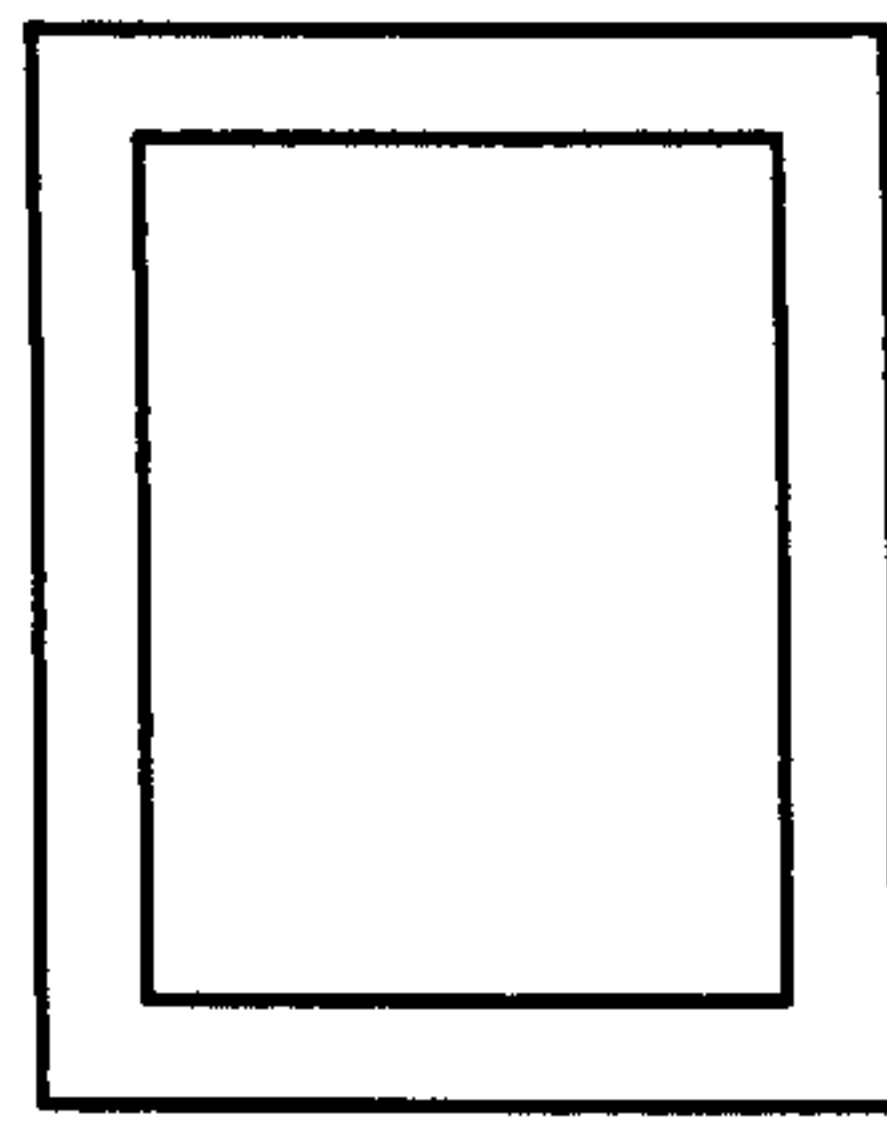
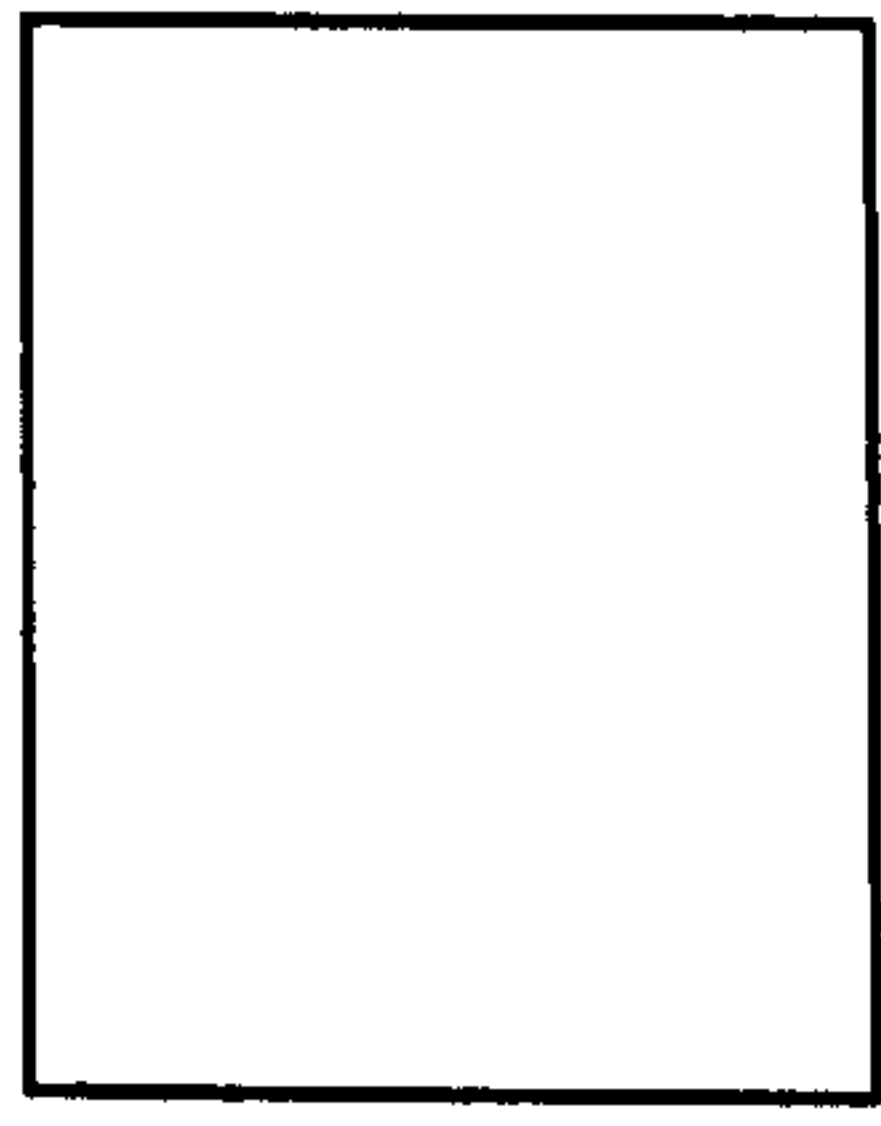

a

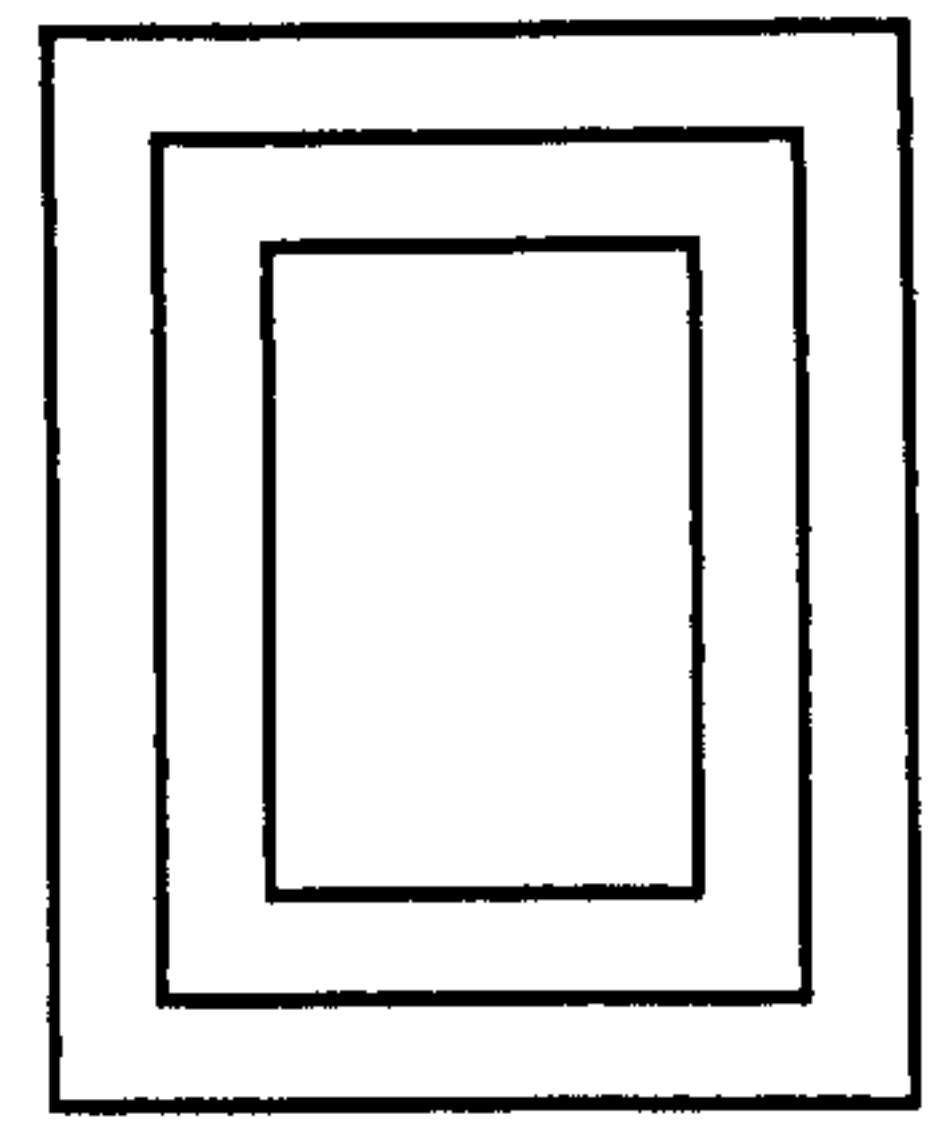

b

Dec 2

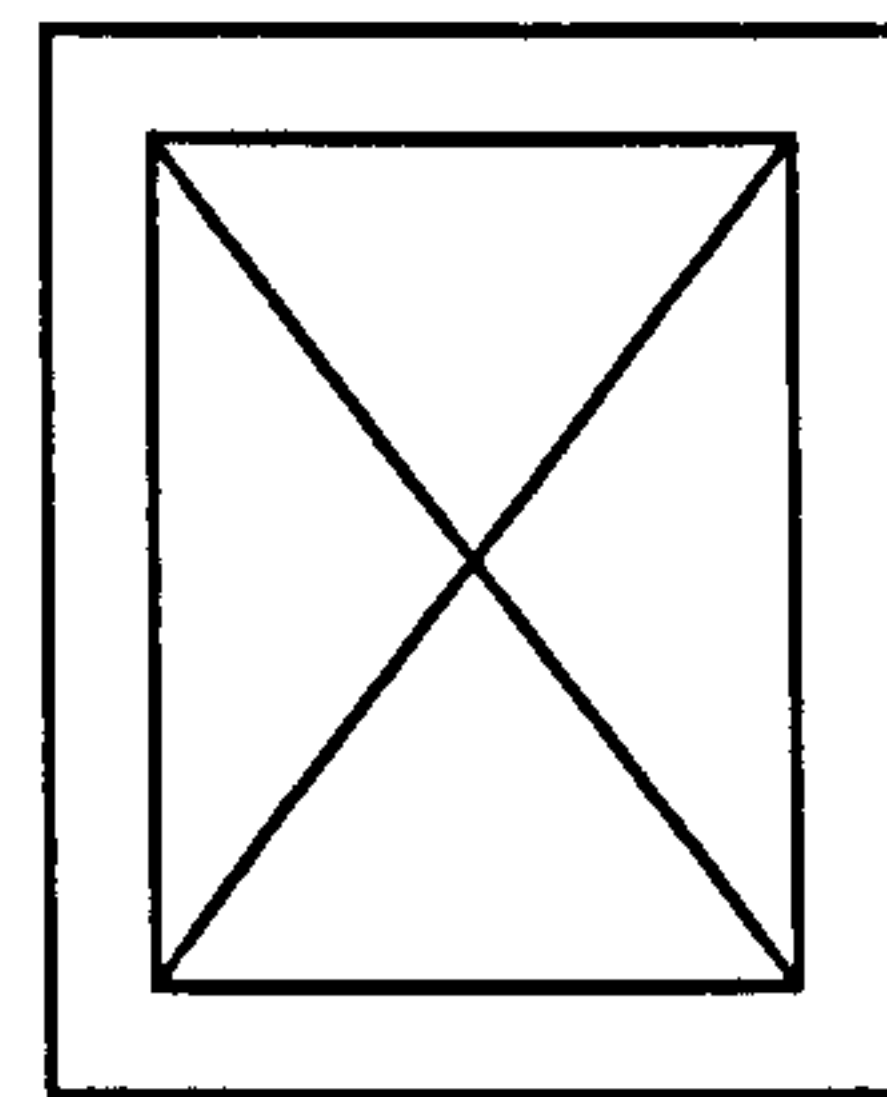
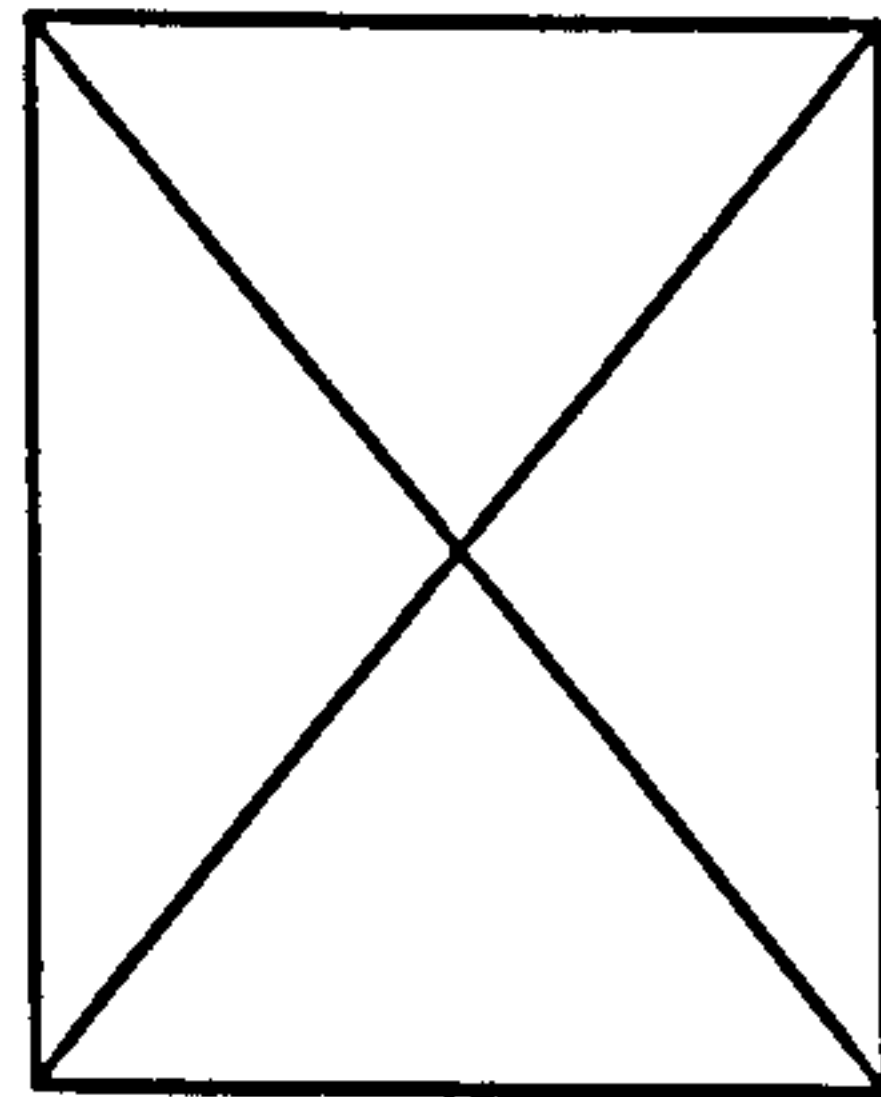

a

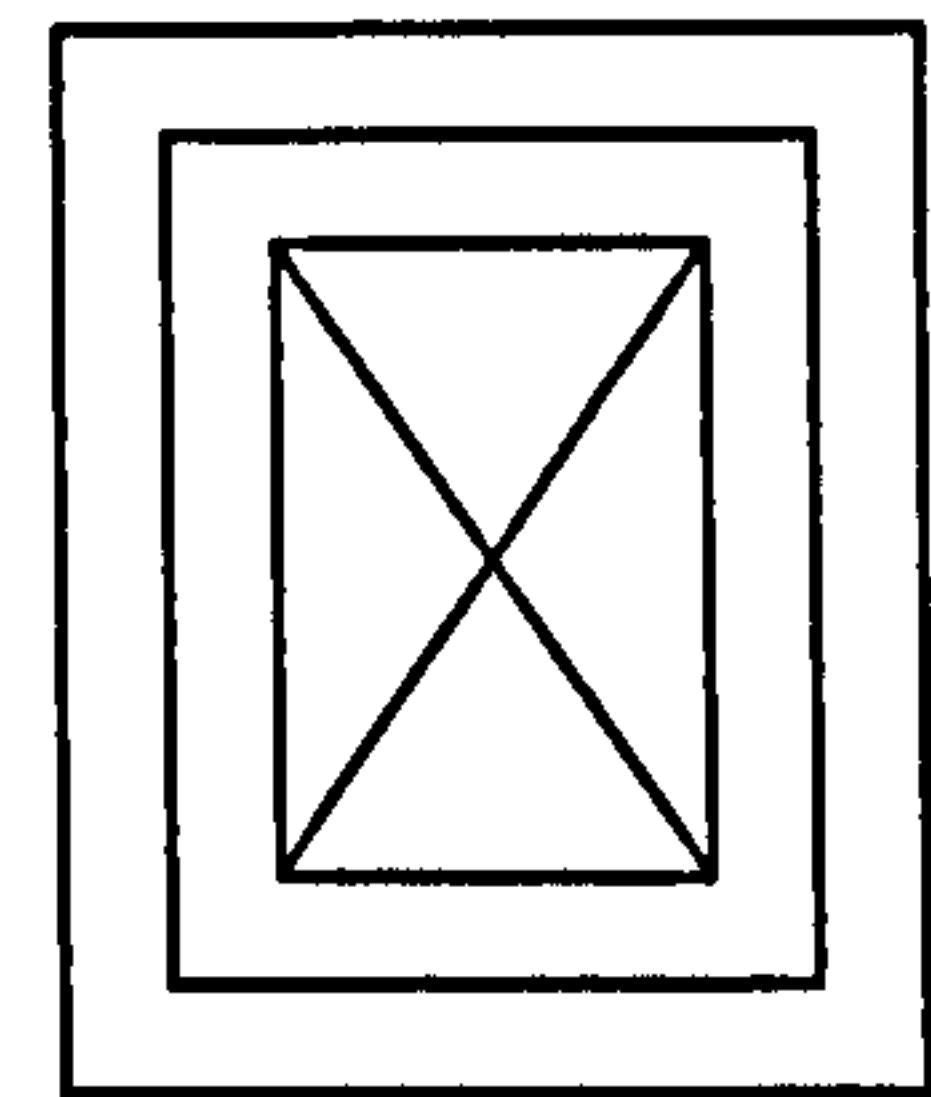

b

Dec 3

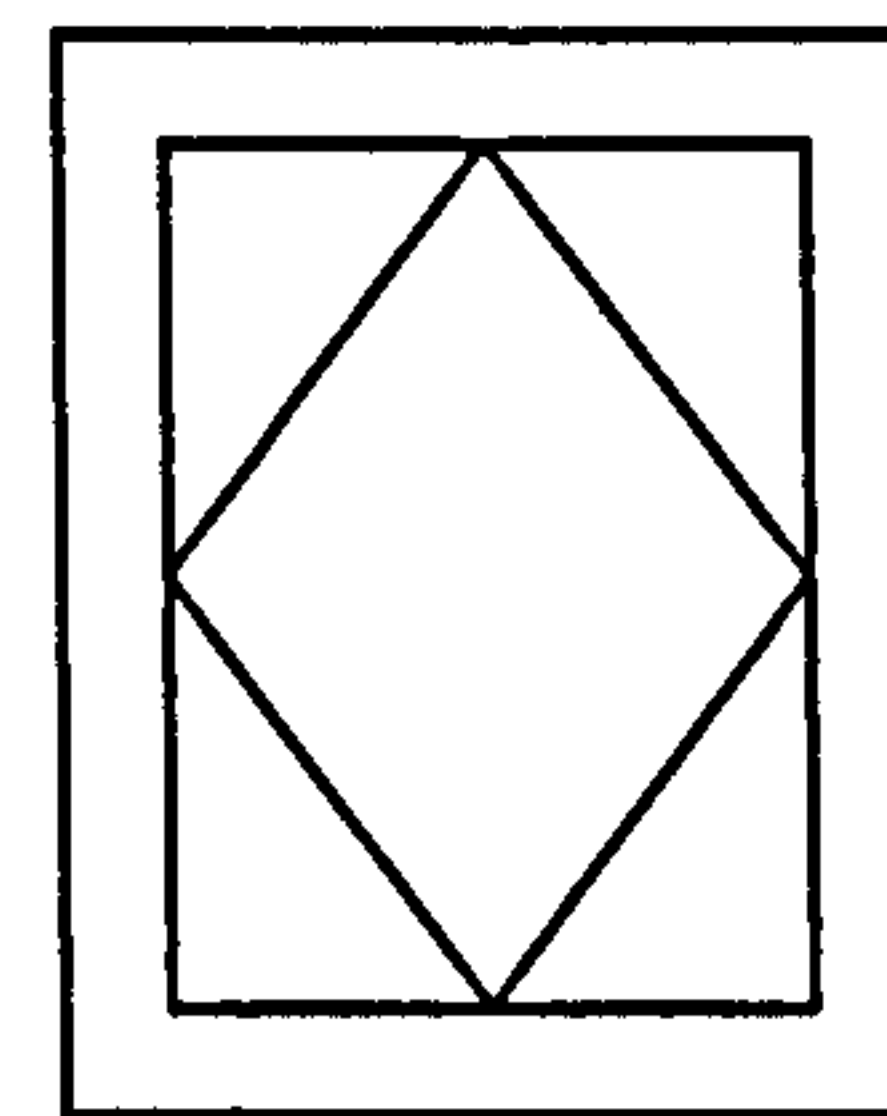
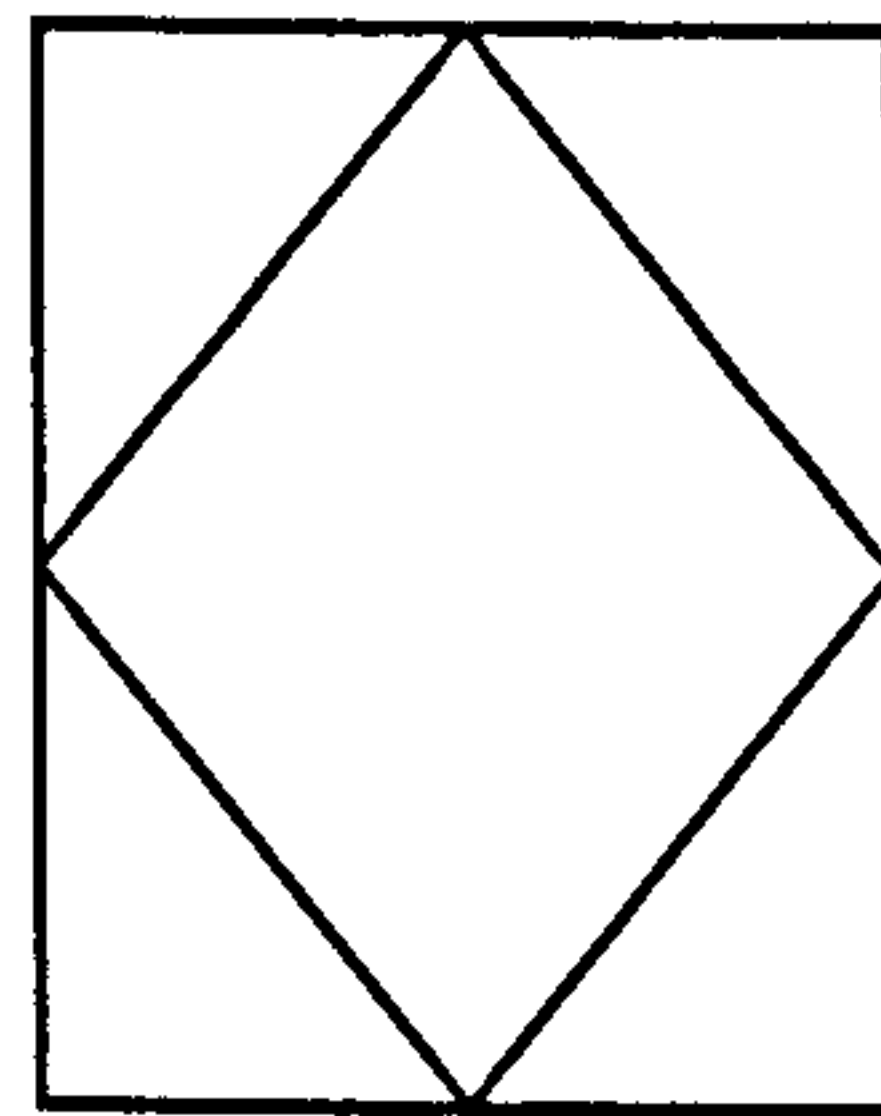

a

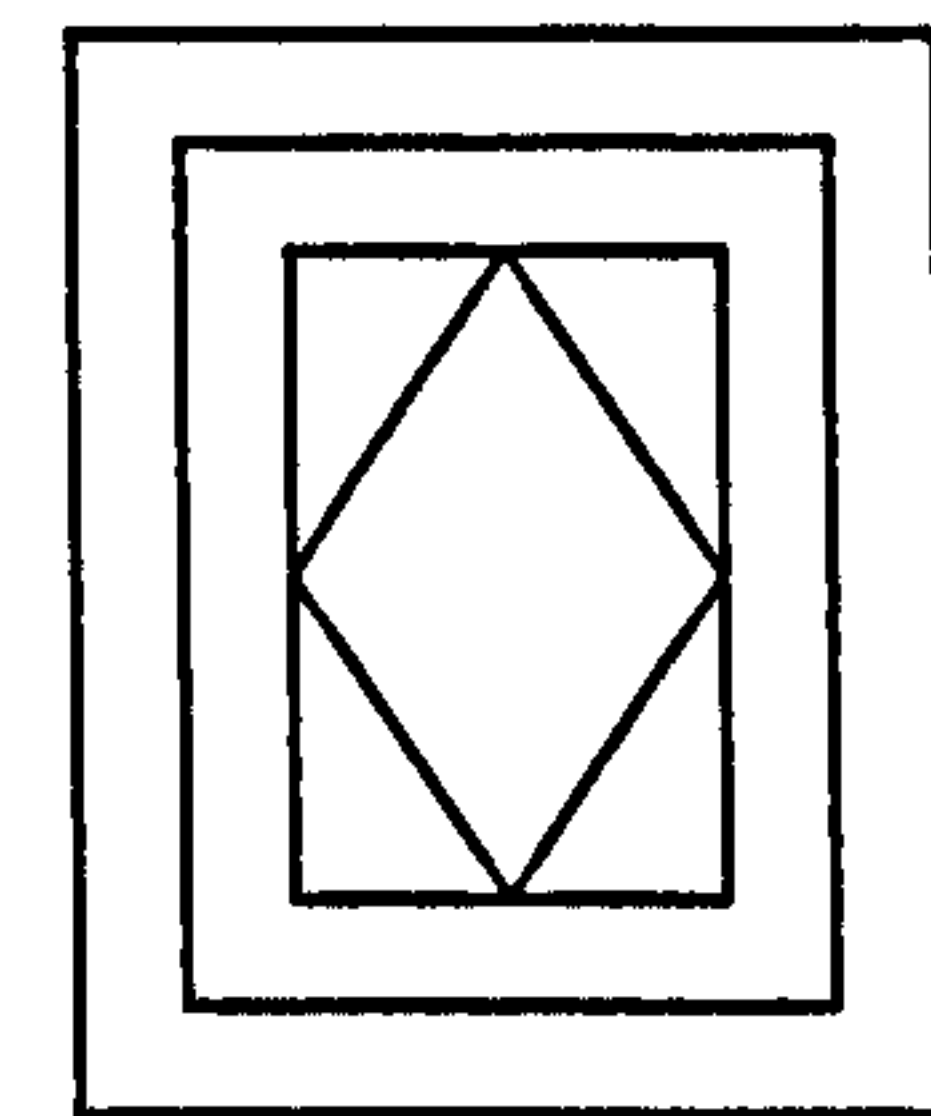

b

Dec 4

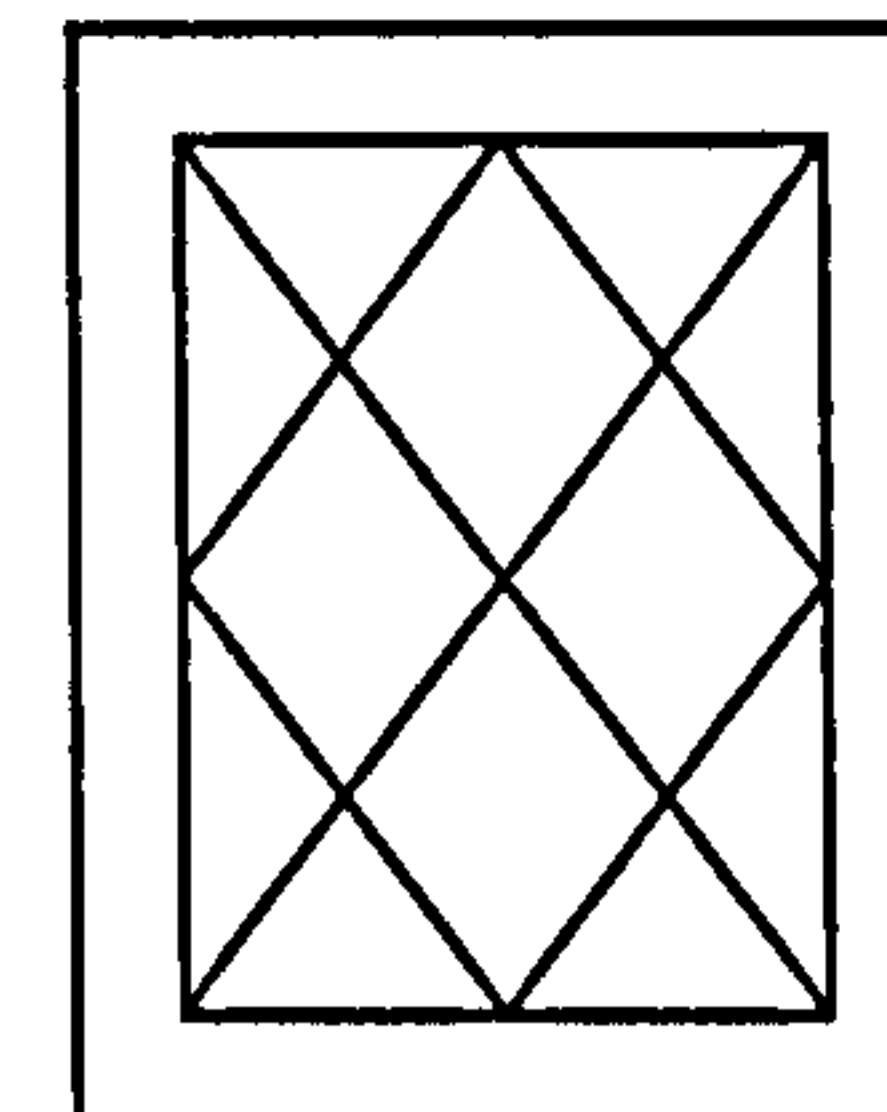
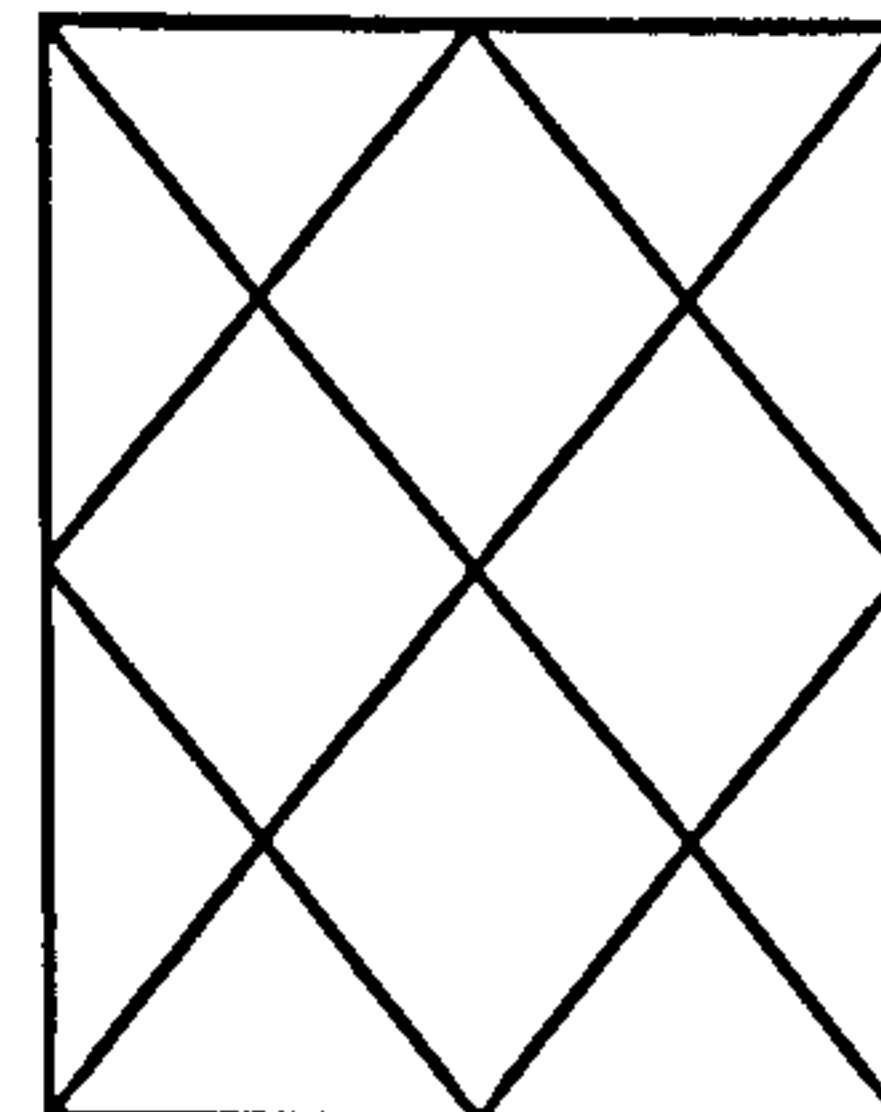

a

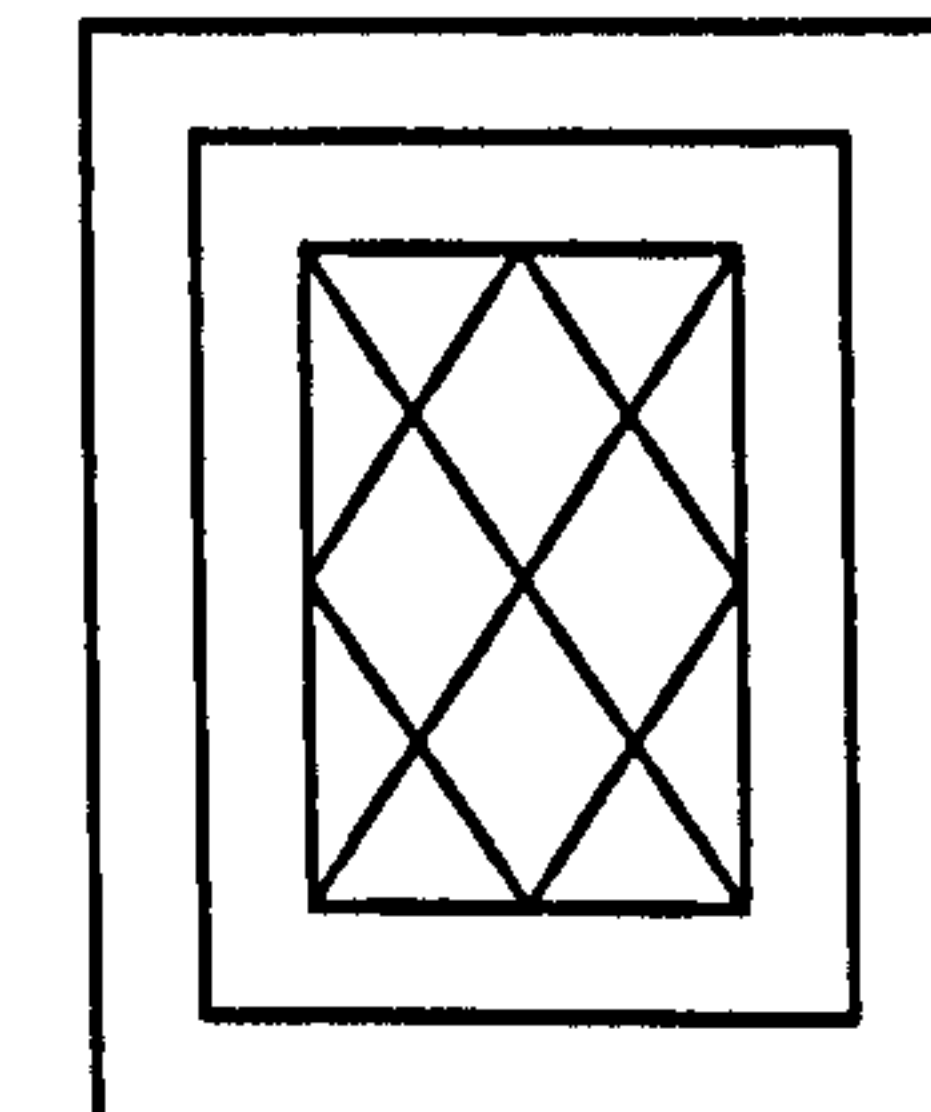

b

Dec 5

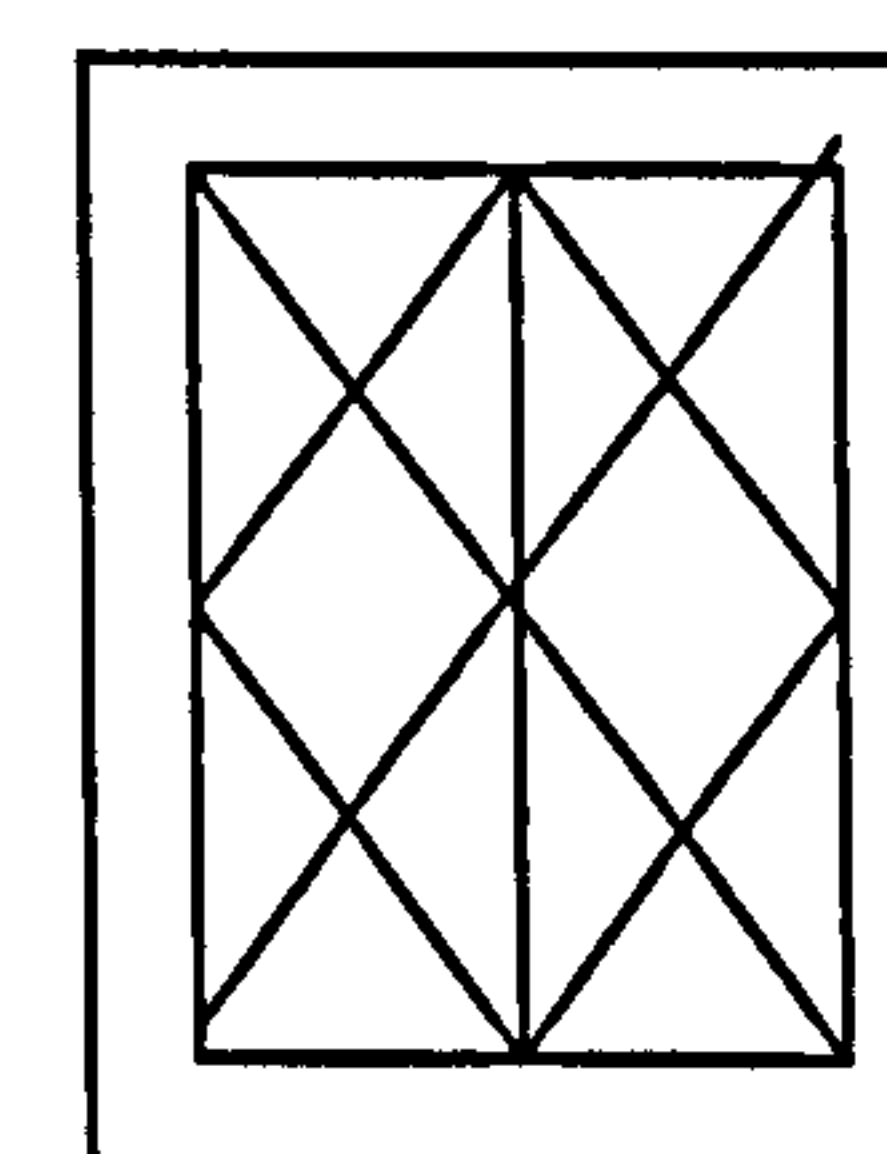
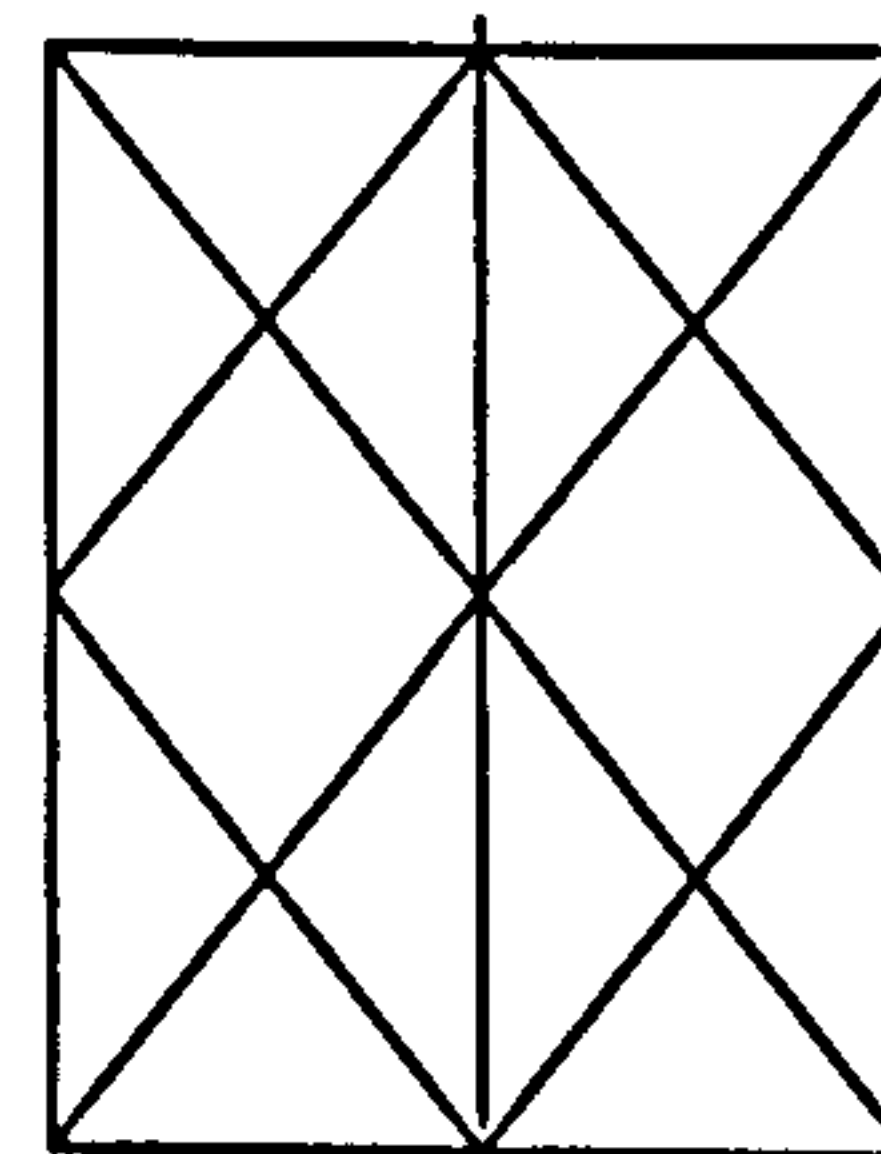

a

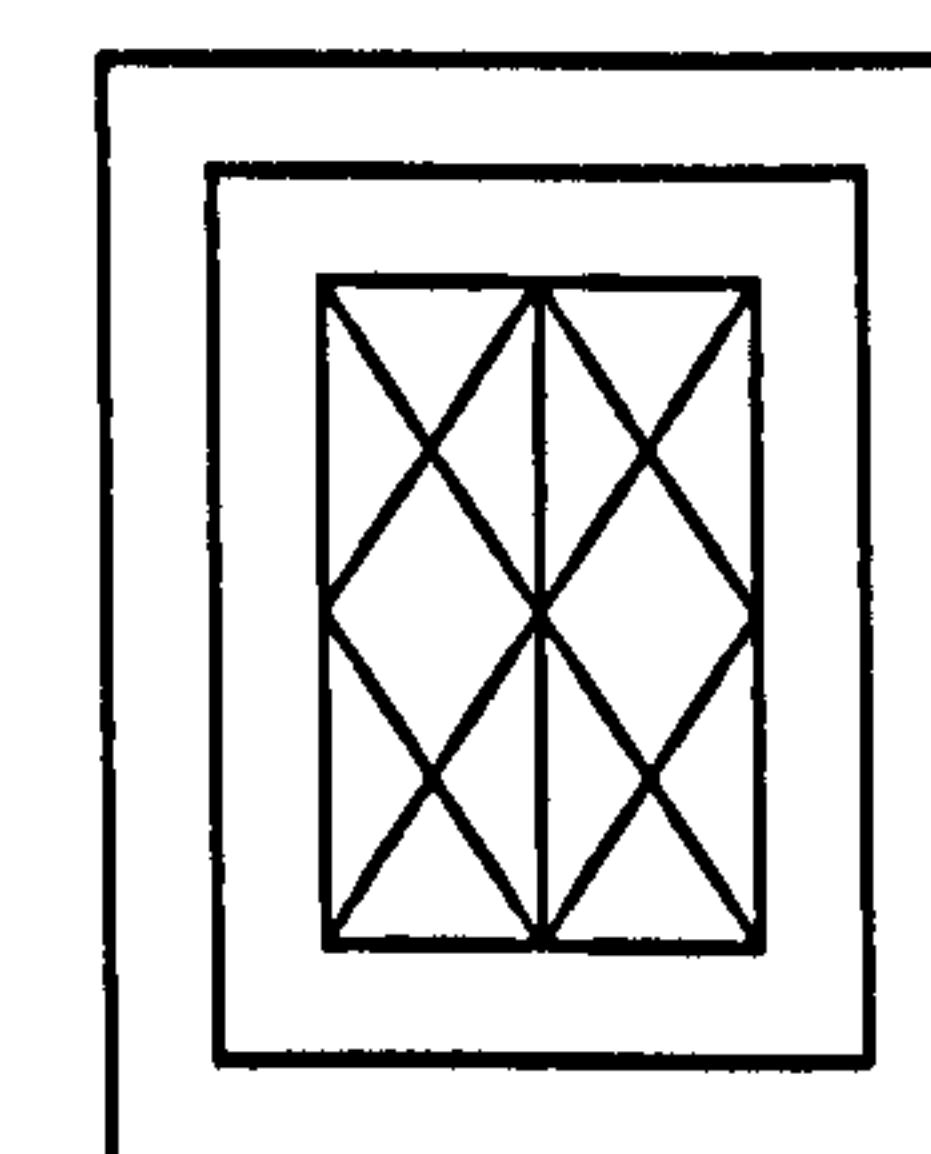

b

Dec 6

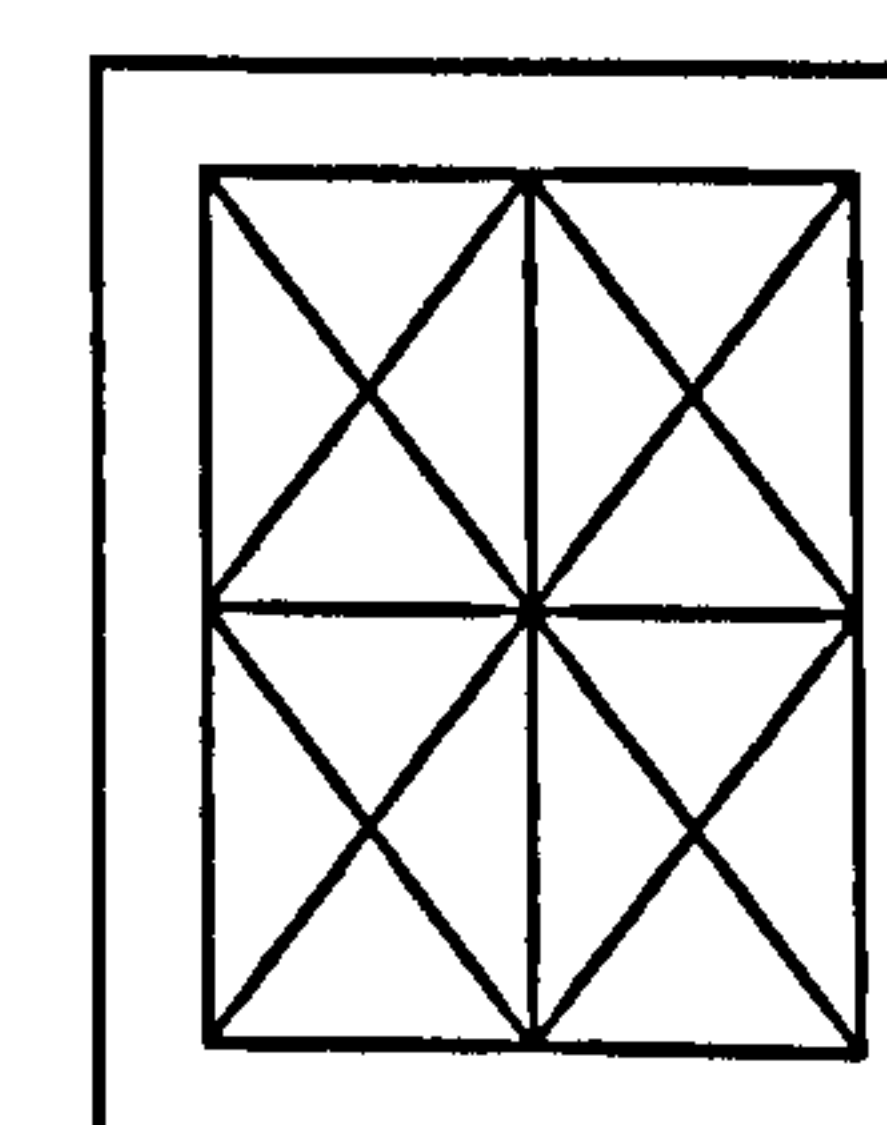
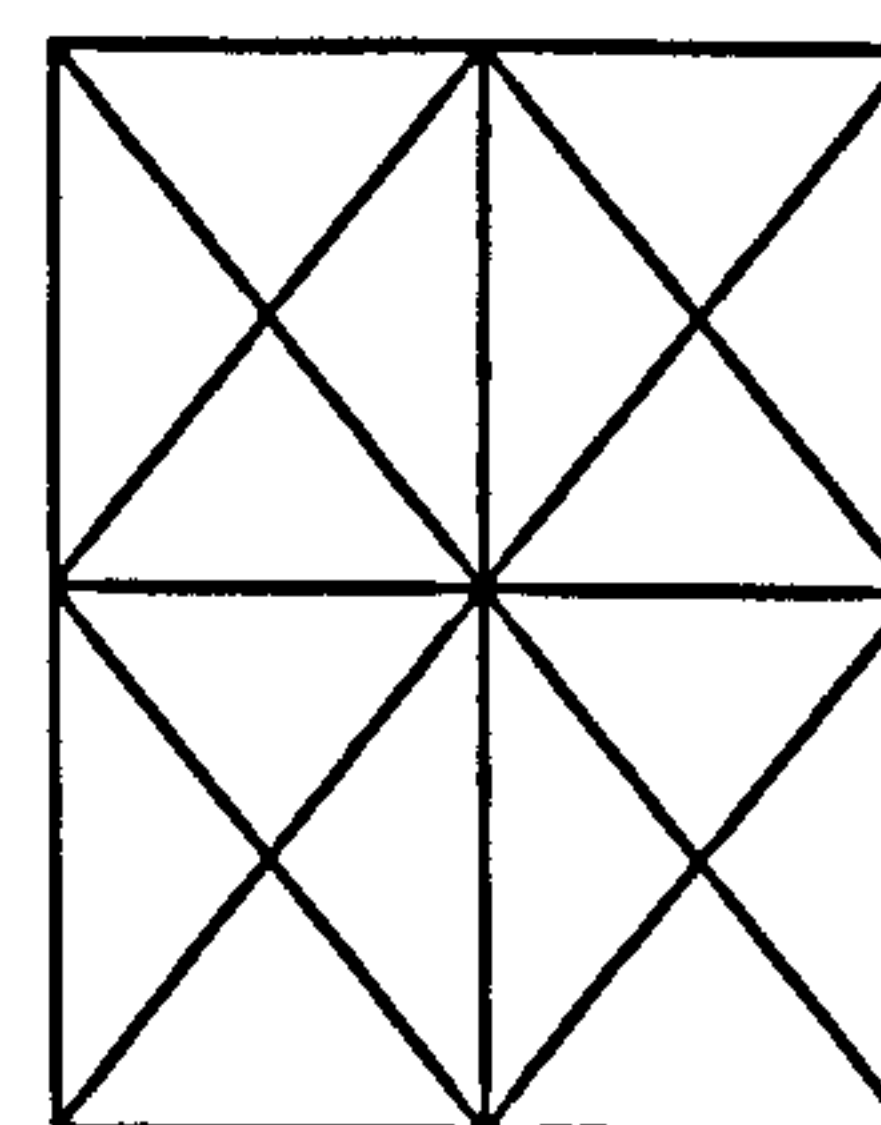

a

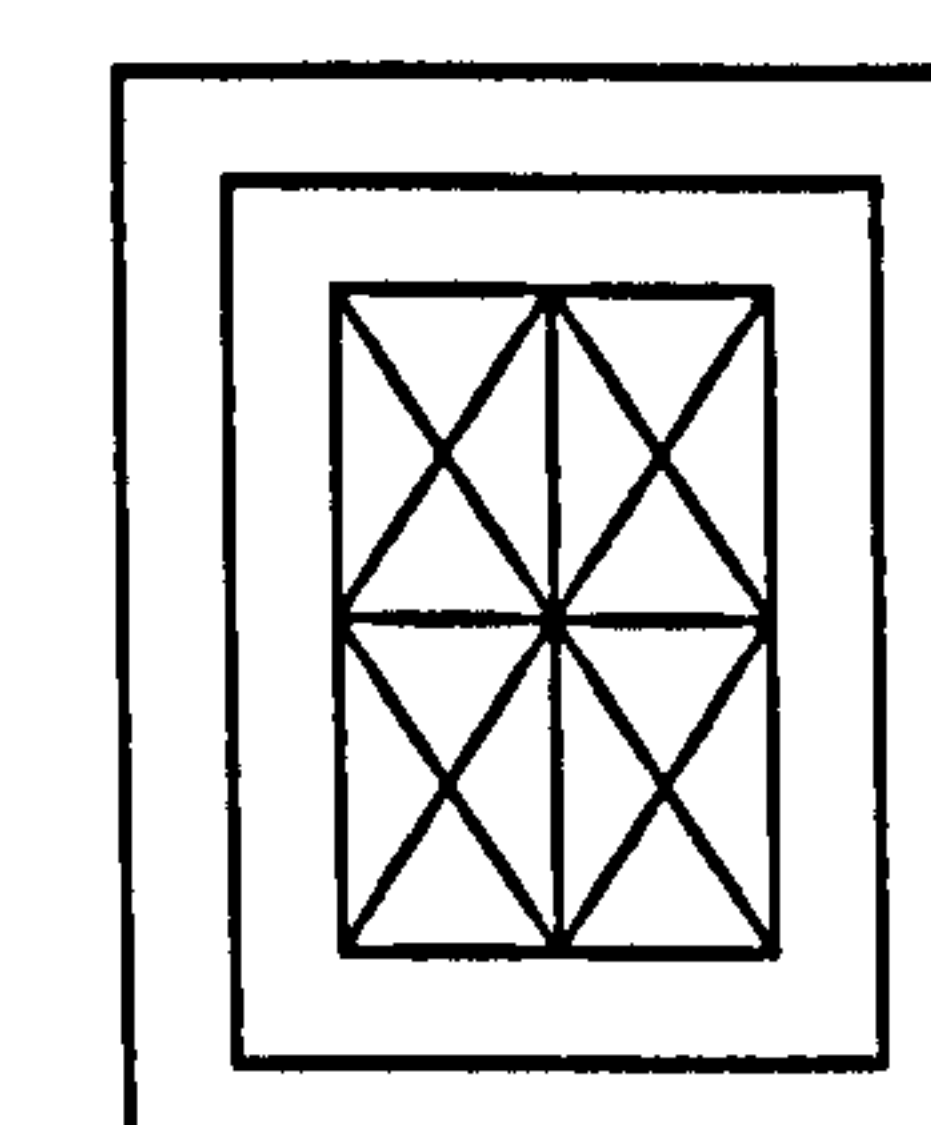

b

Dec 7

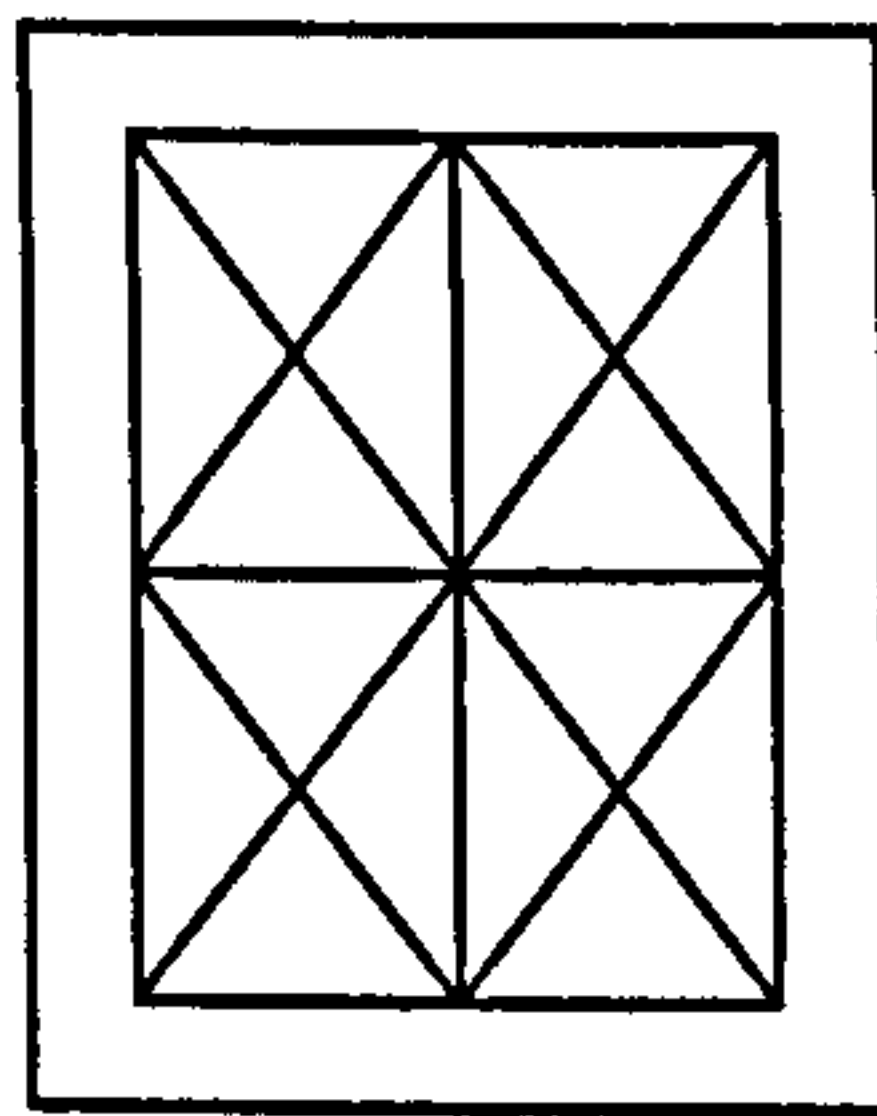
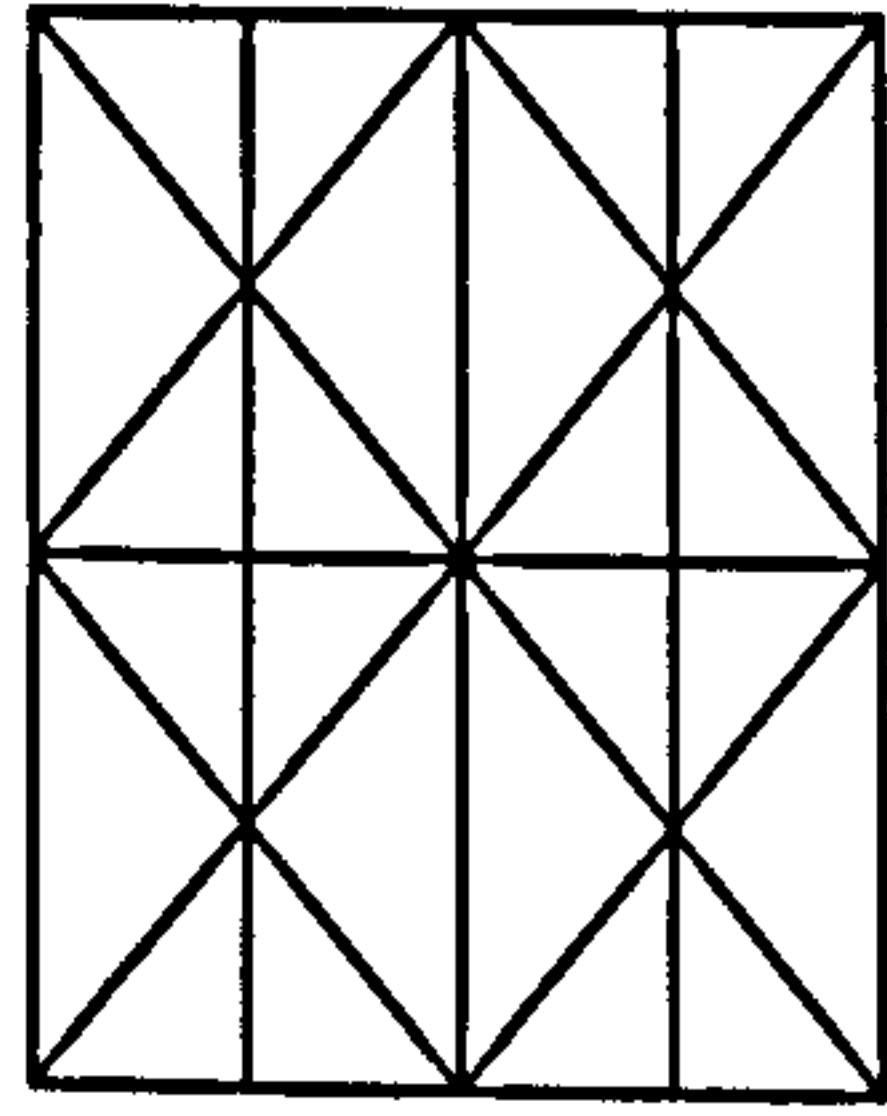

a

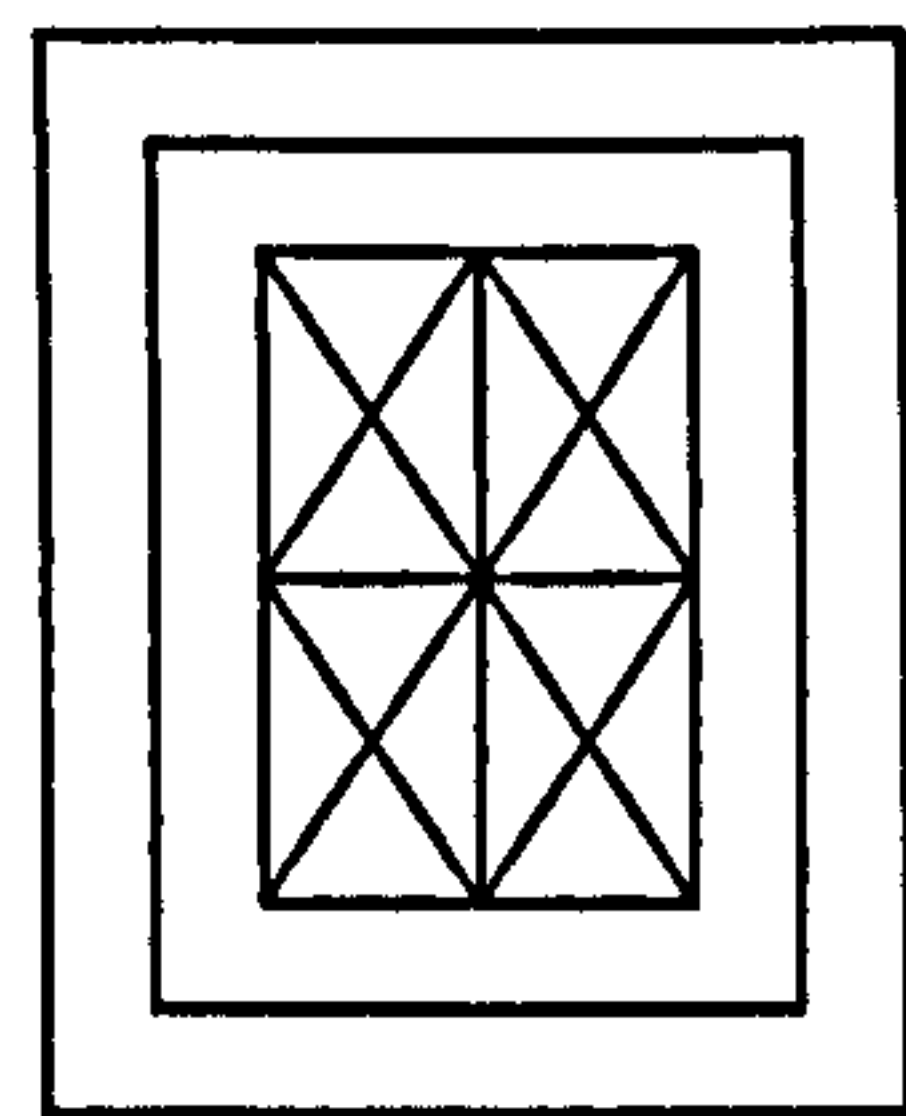

b

Dec 8

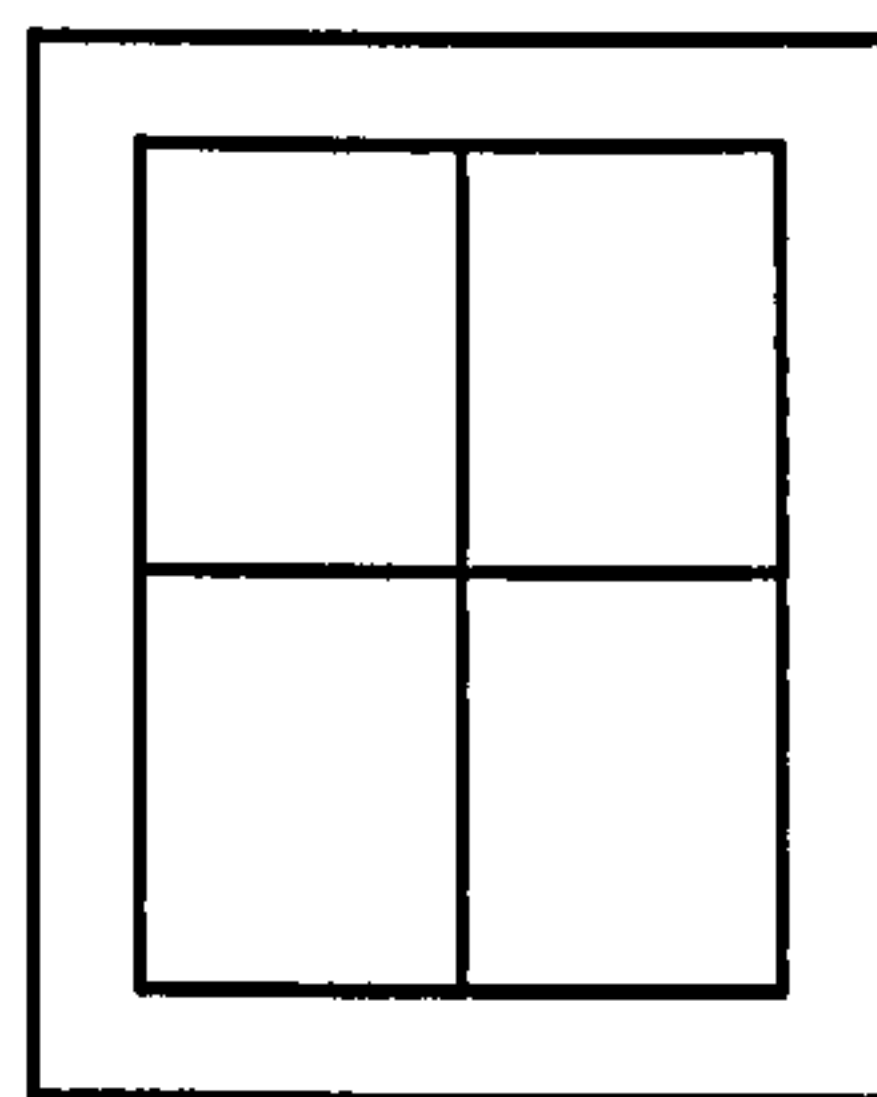
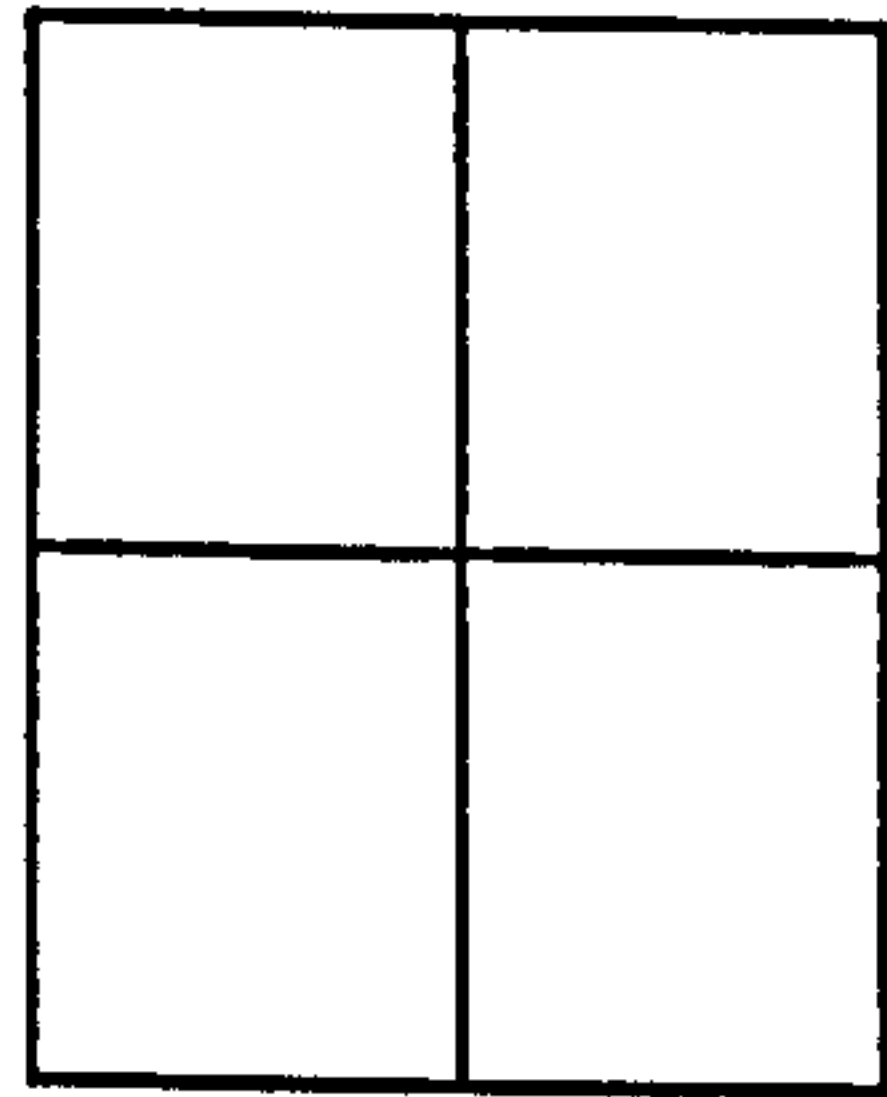

a

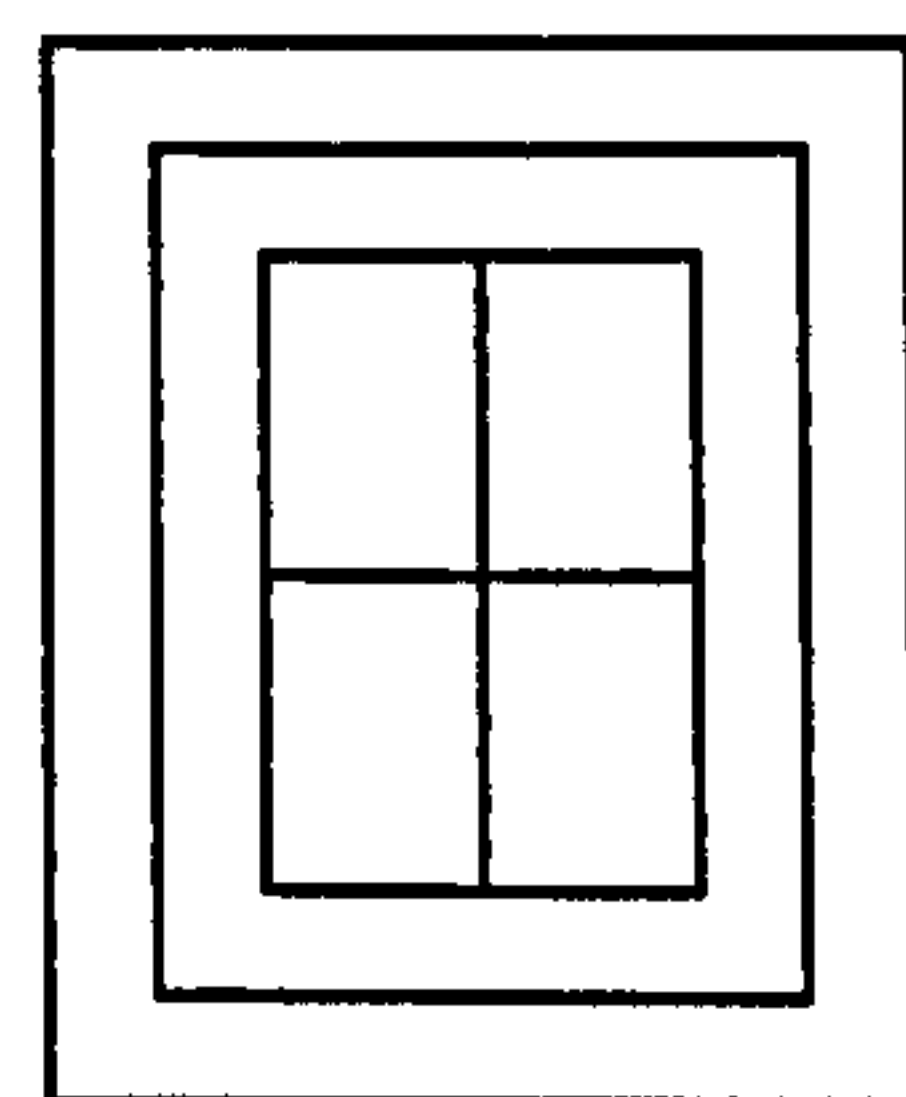

b

Dec 9

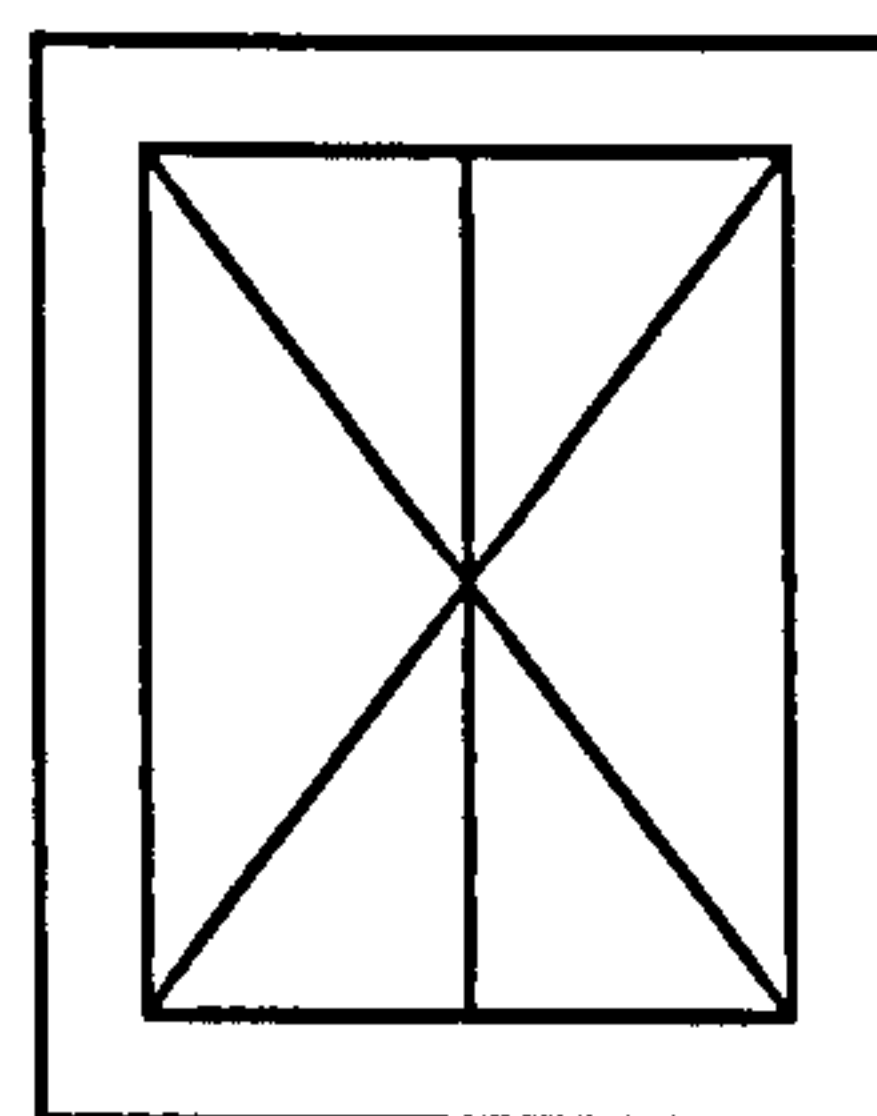
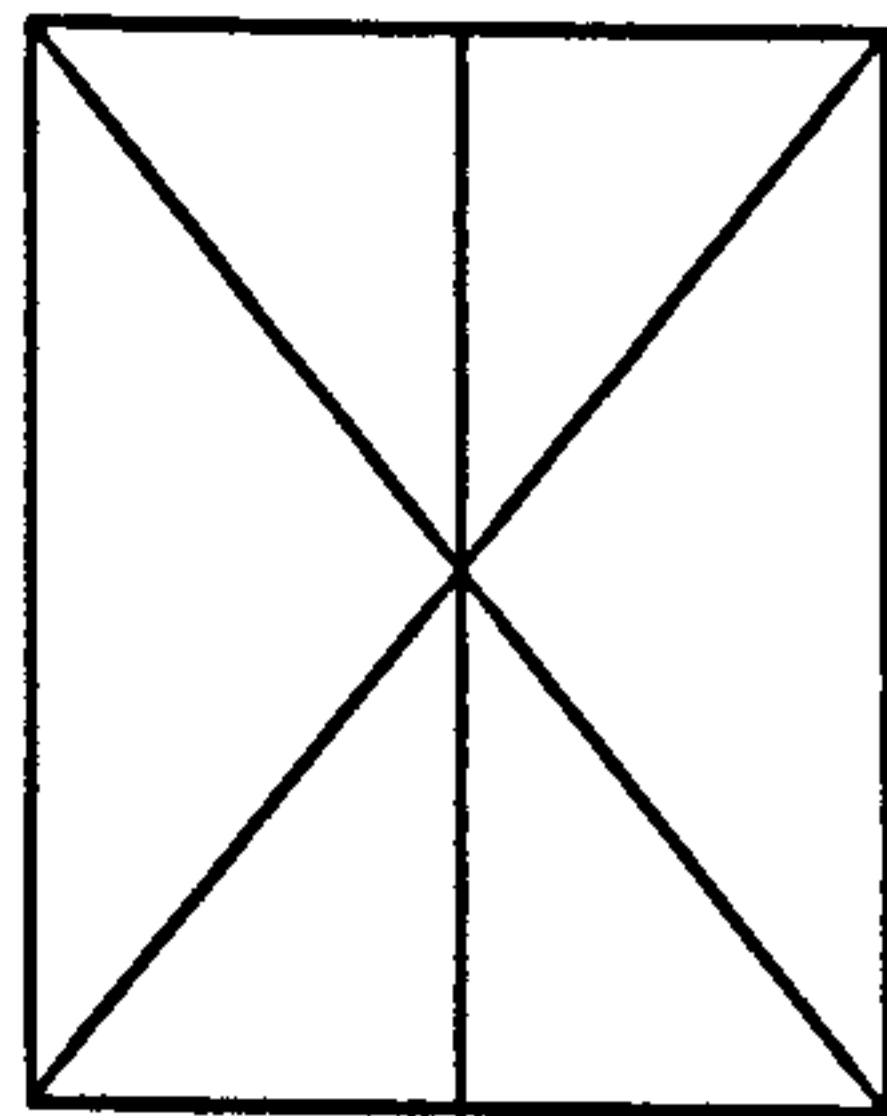

a

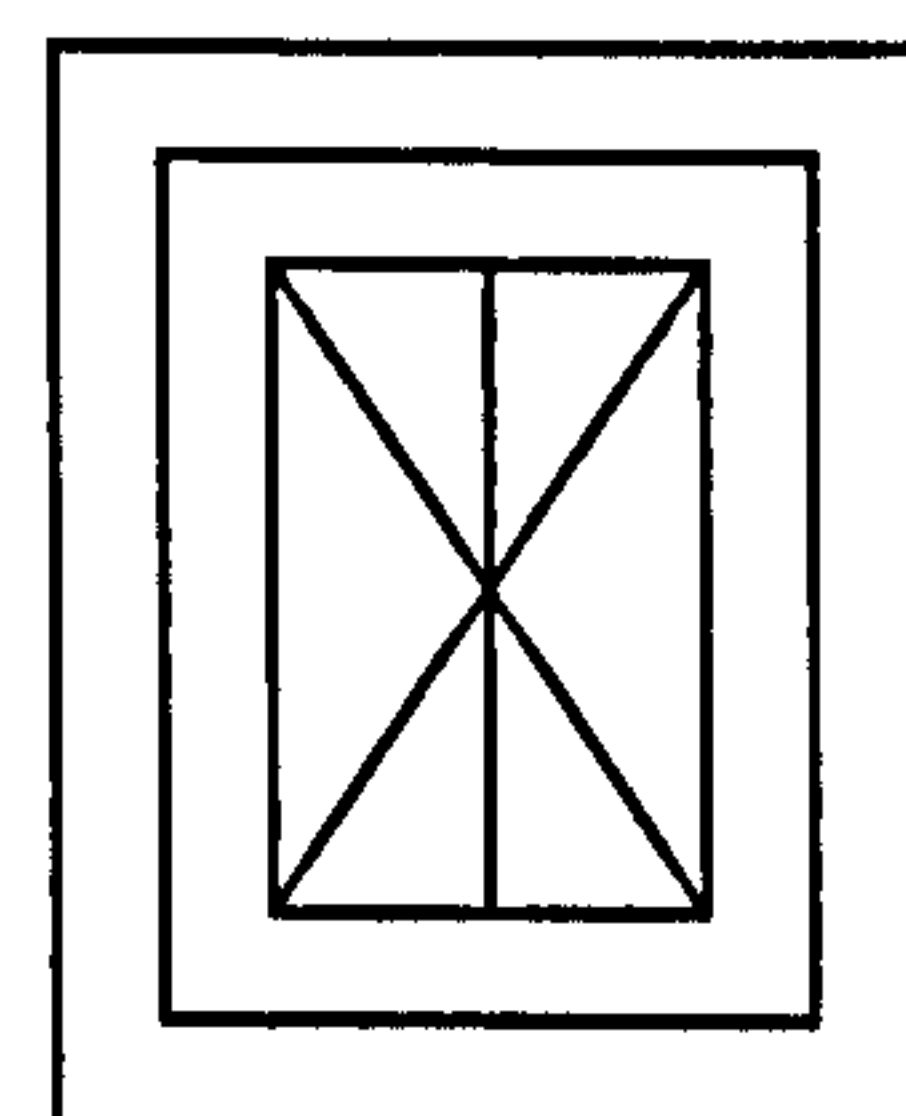

b

Dec 10

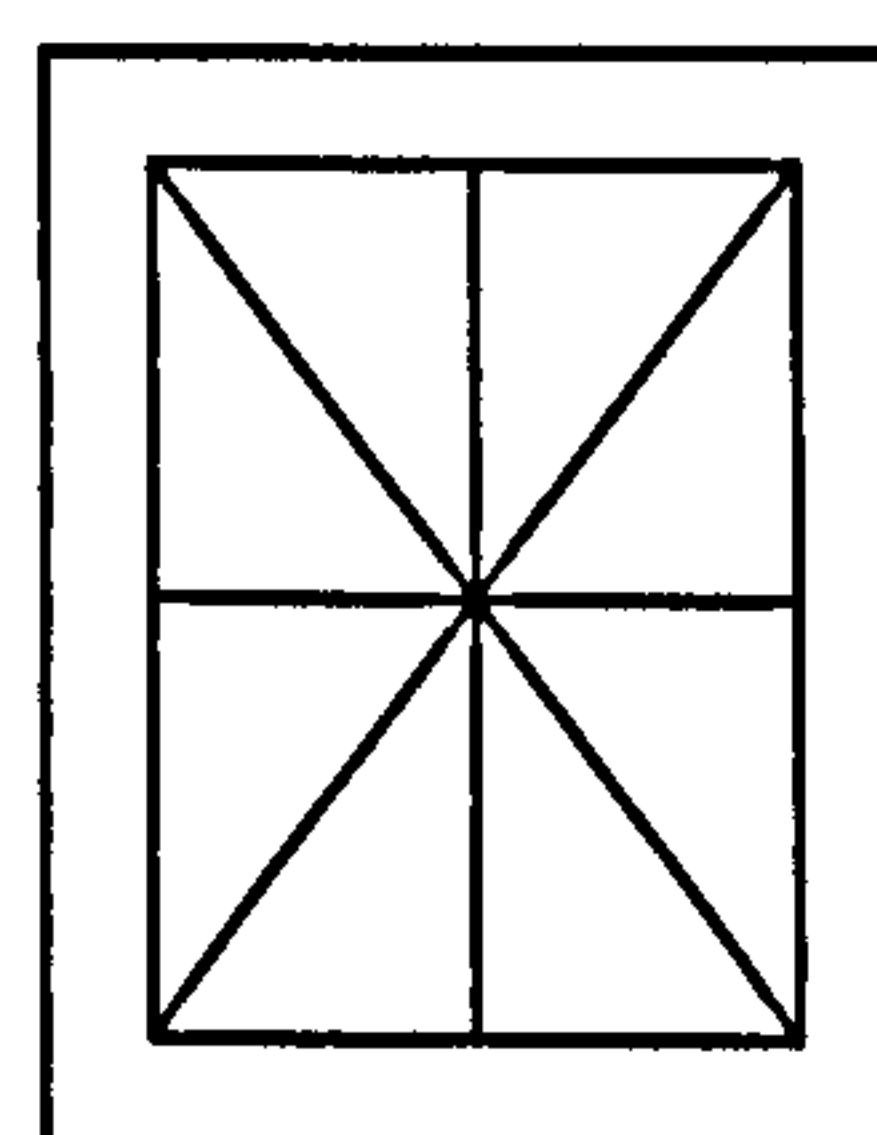
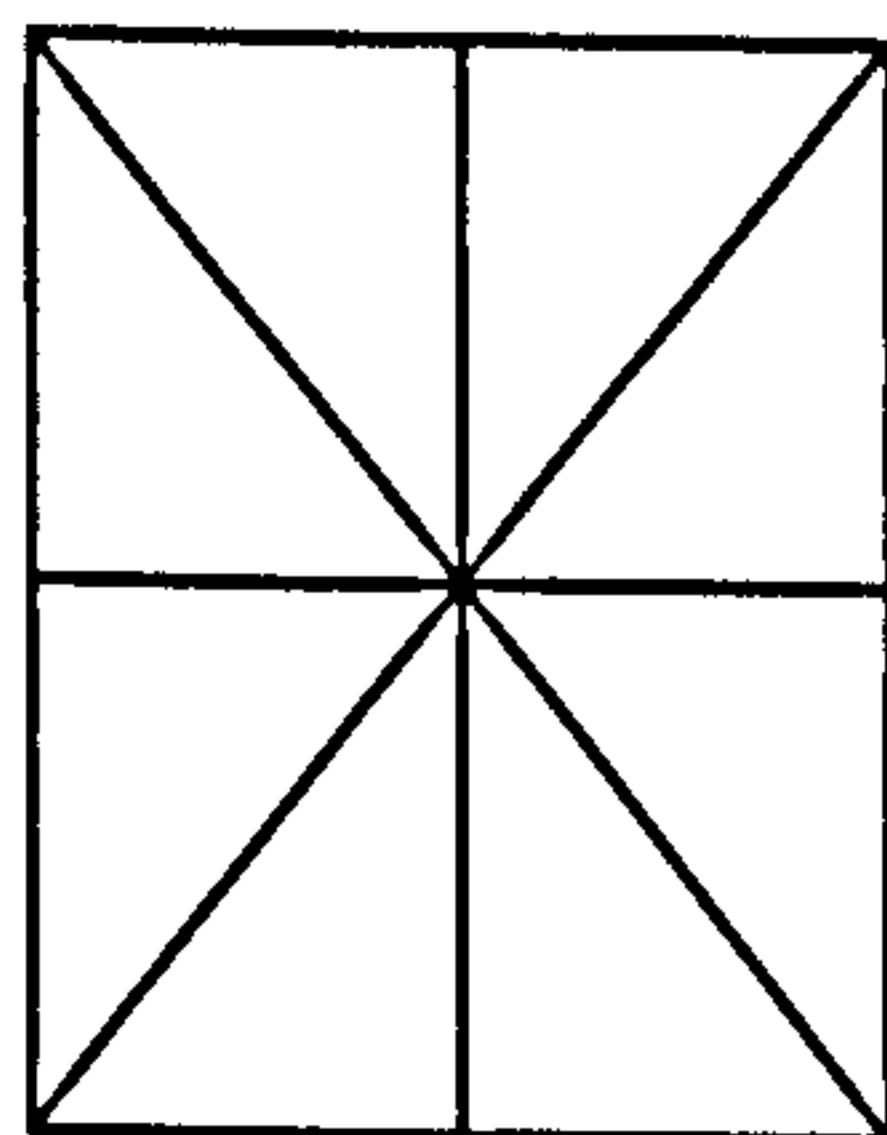

a

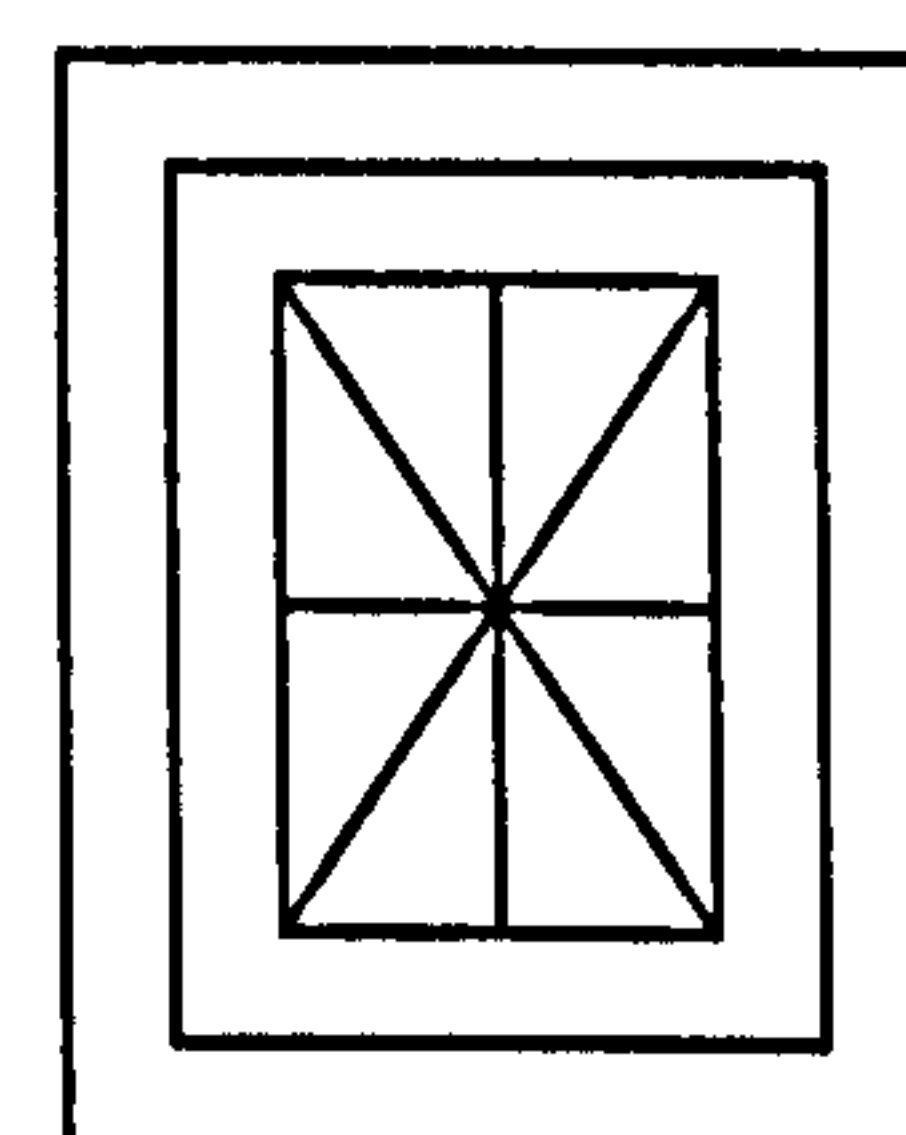

b

Dec 11

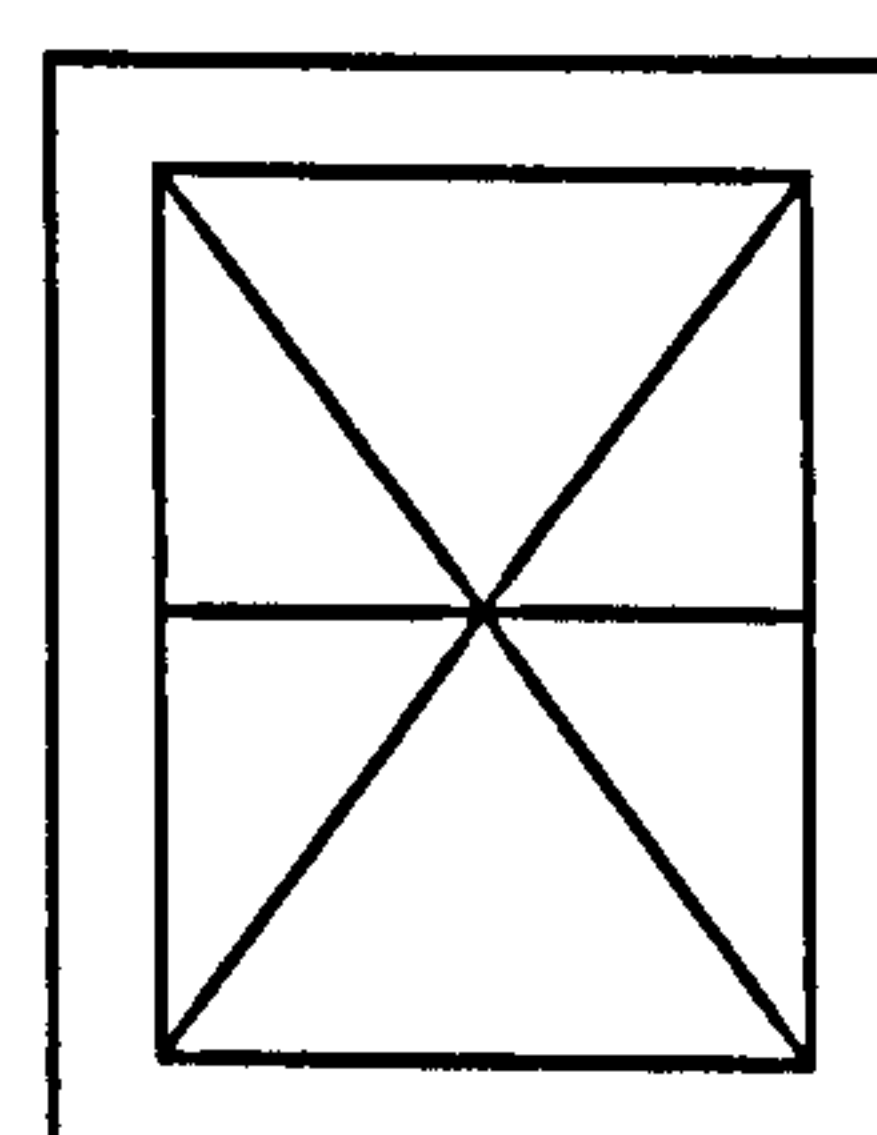
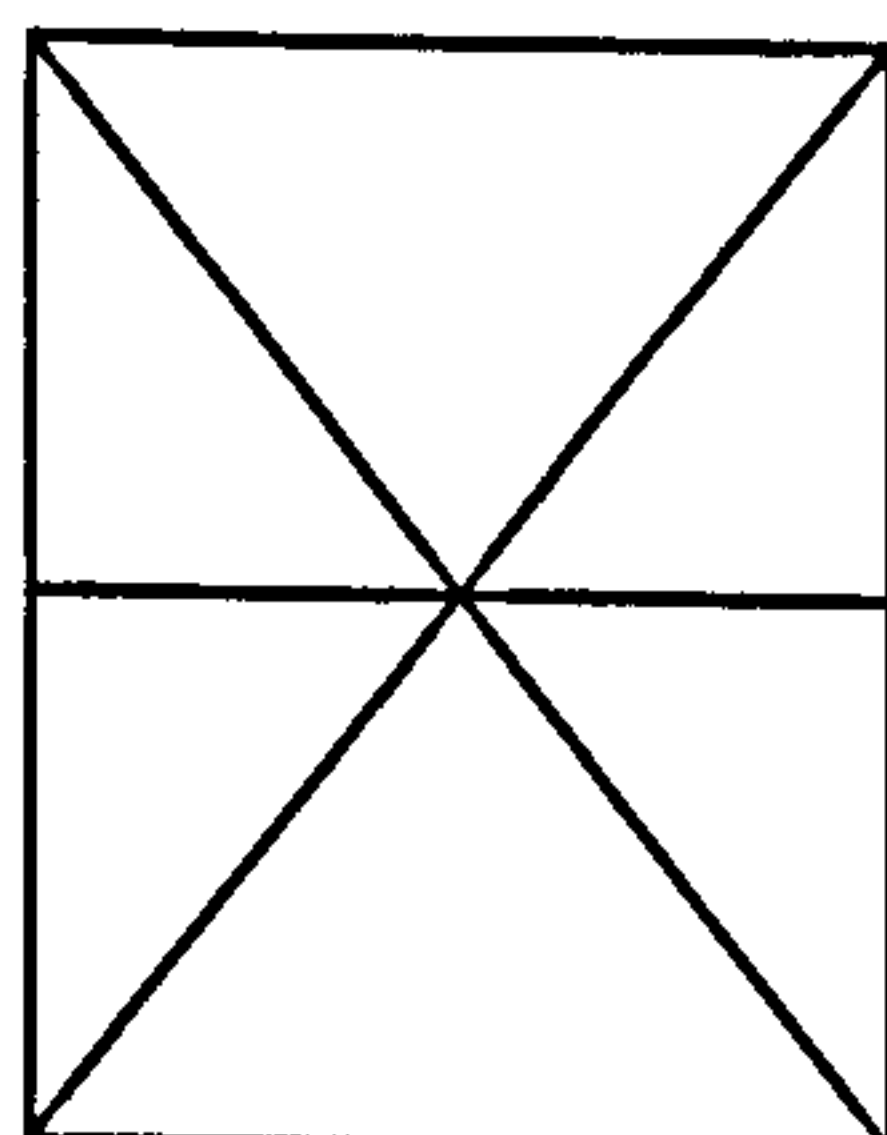

a

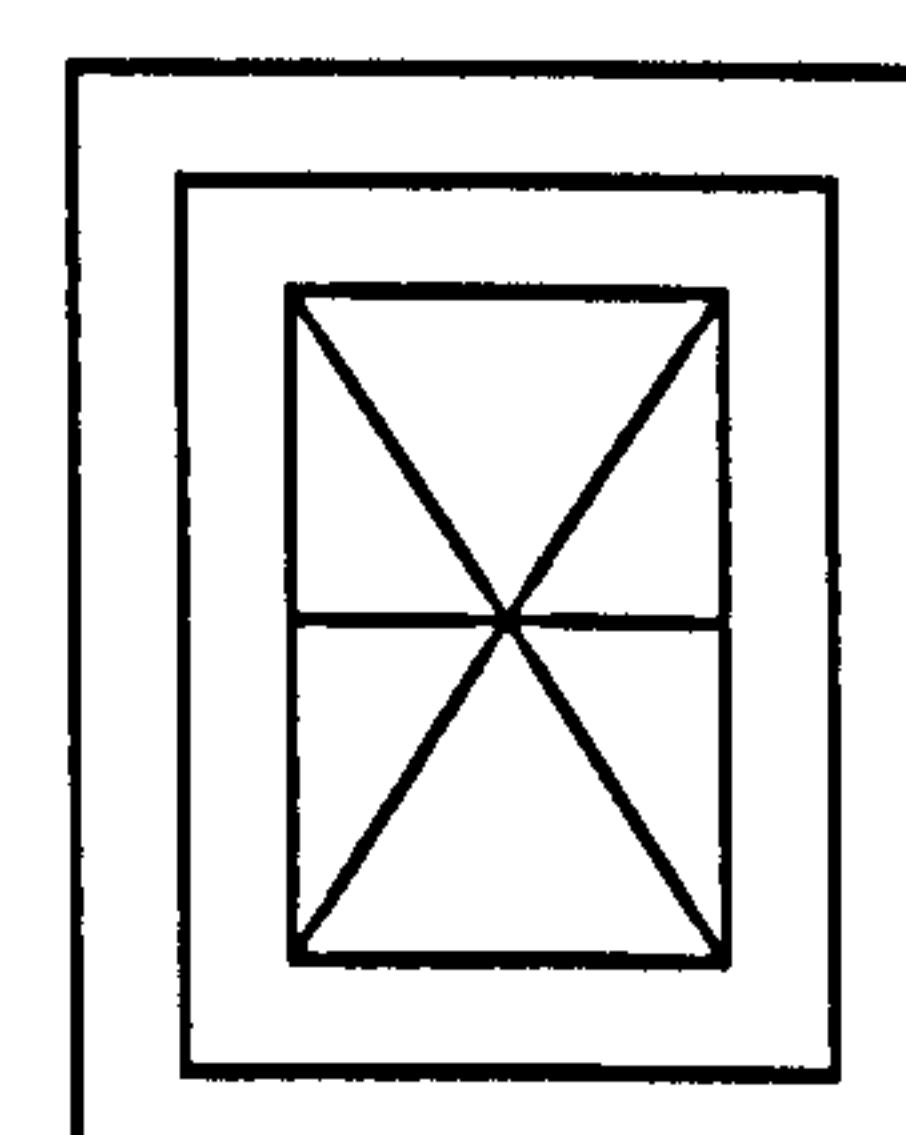

b

Dec 12

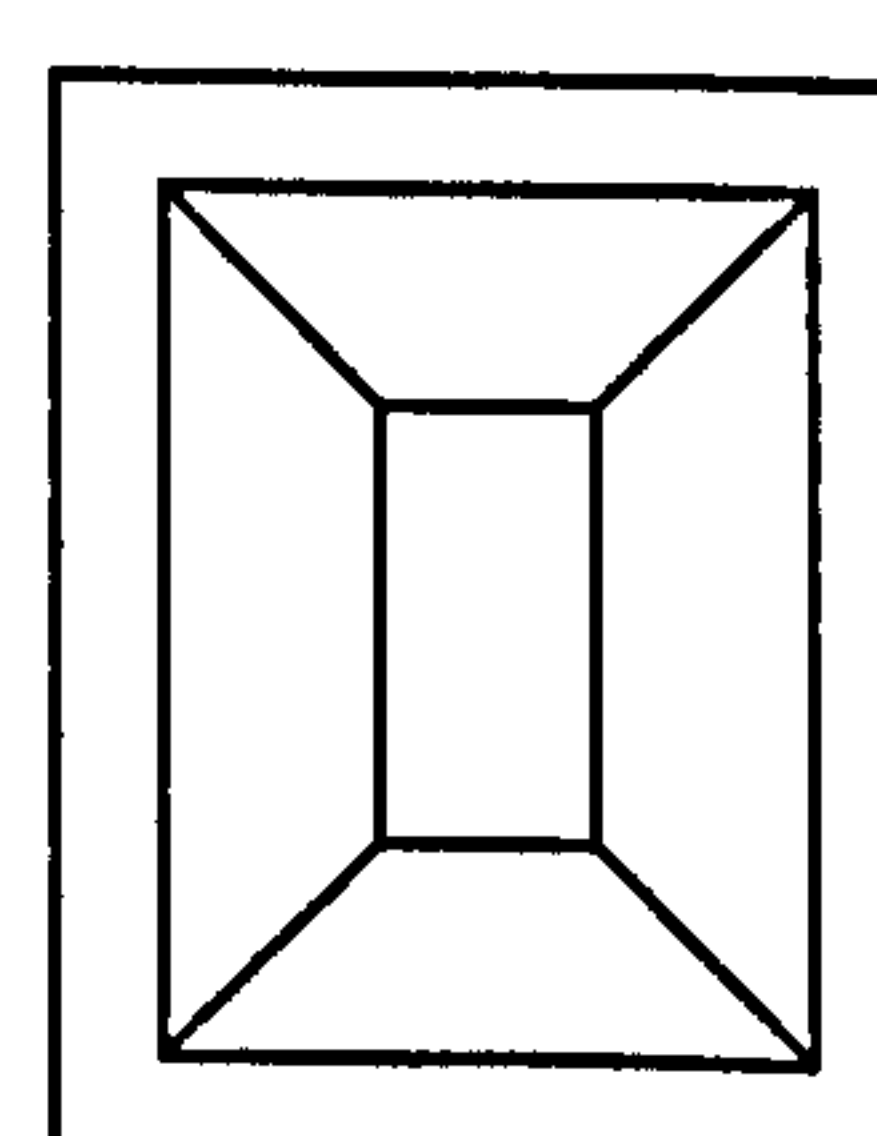
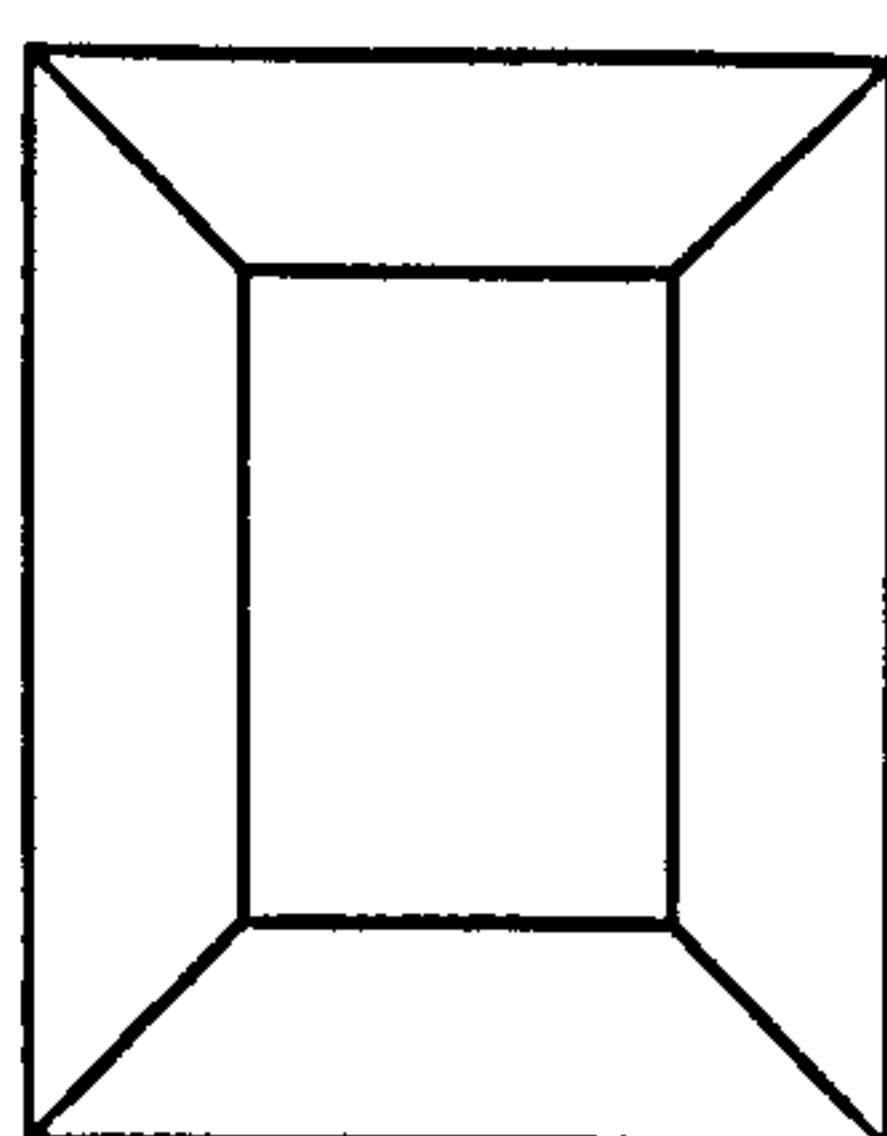

a

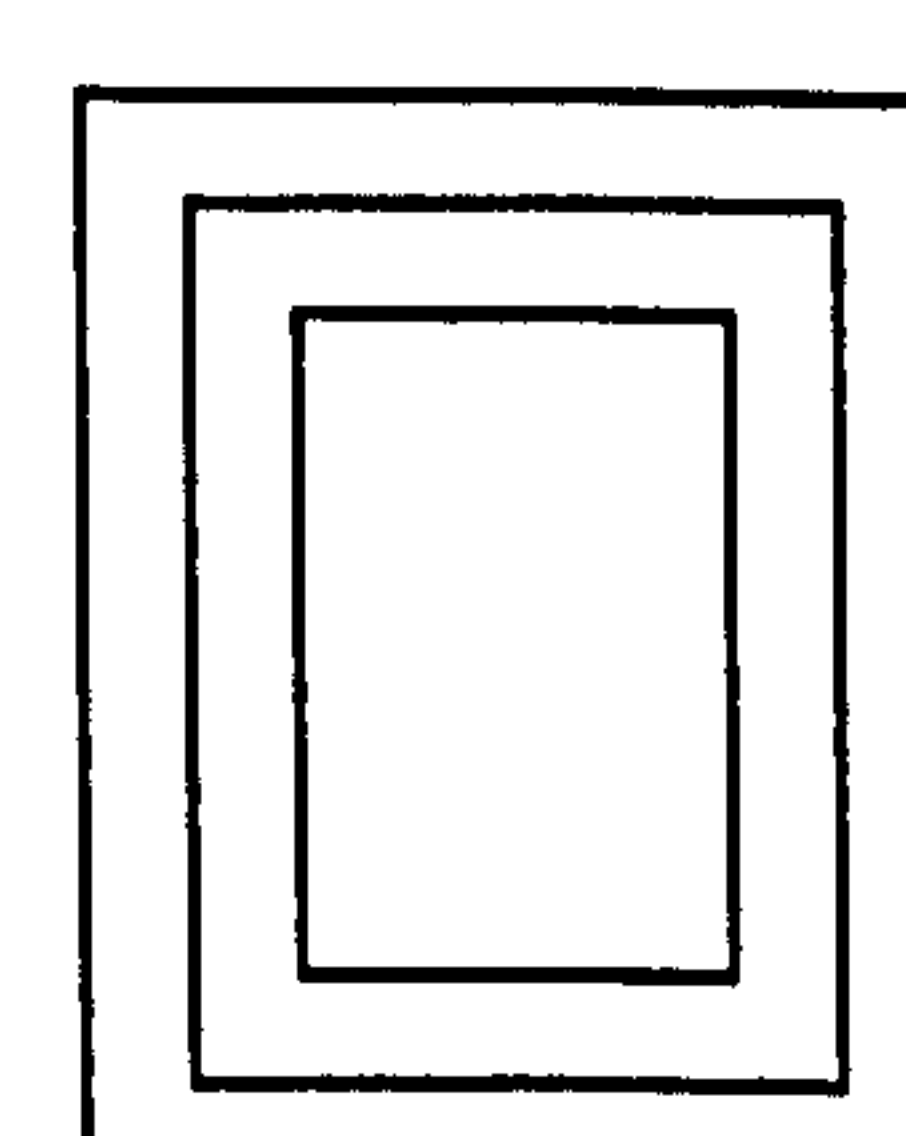

b

Dec 13

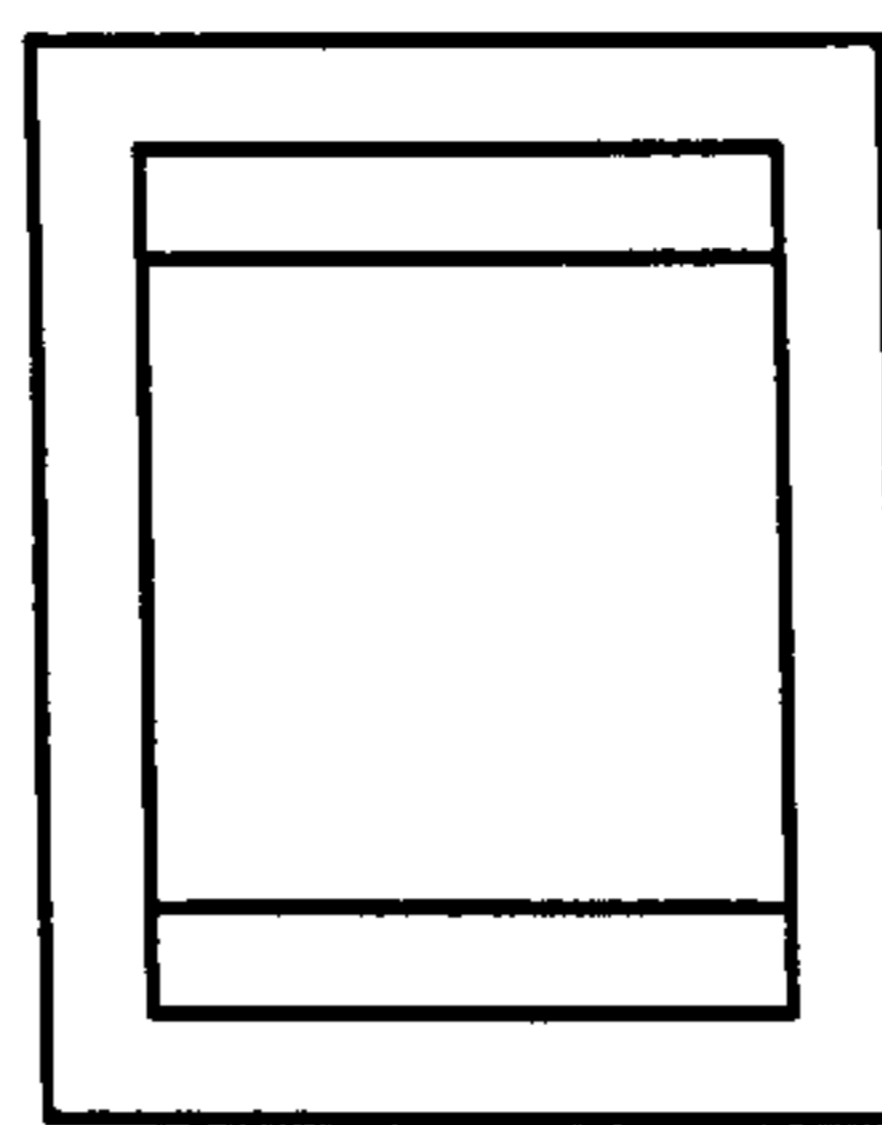
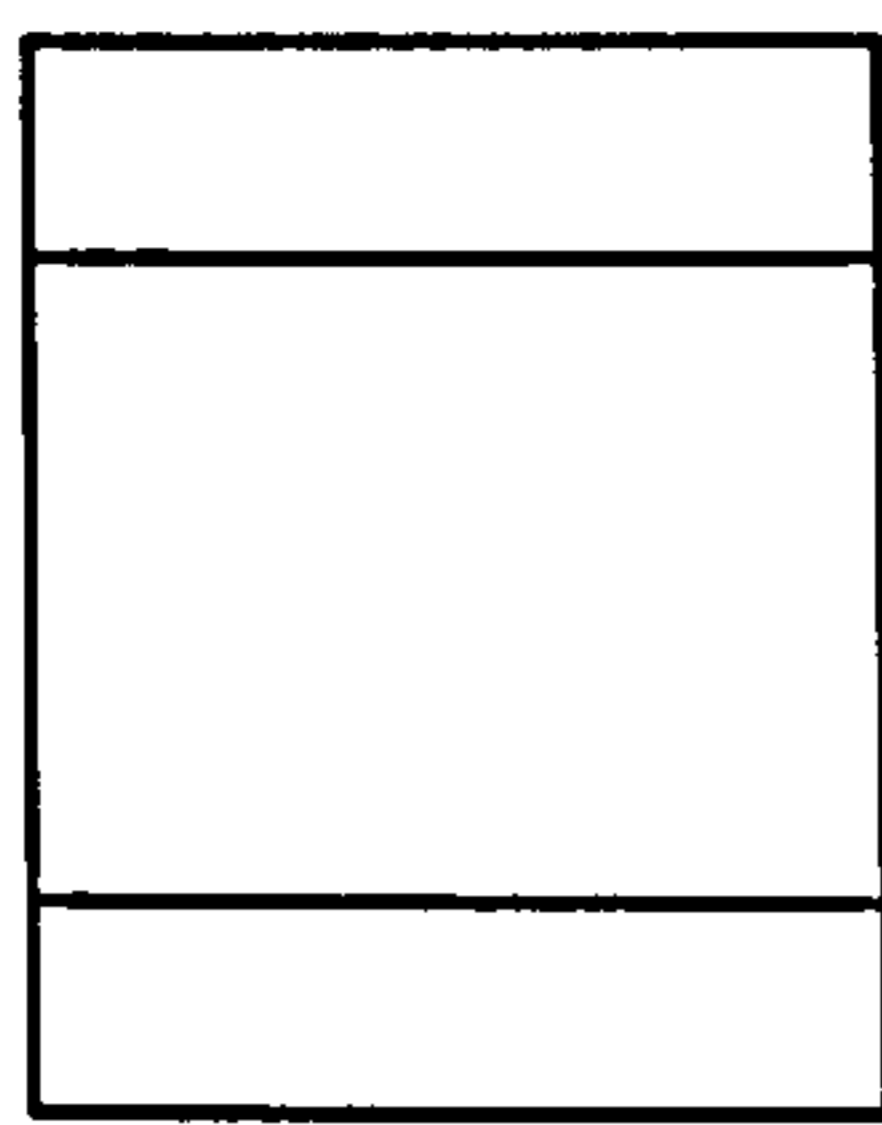

a

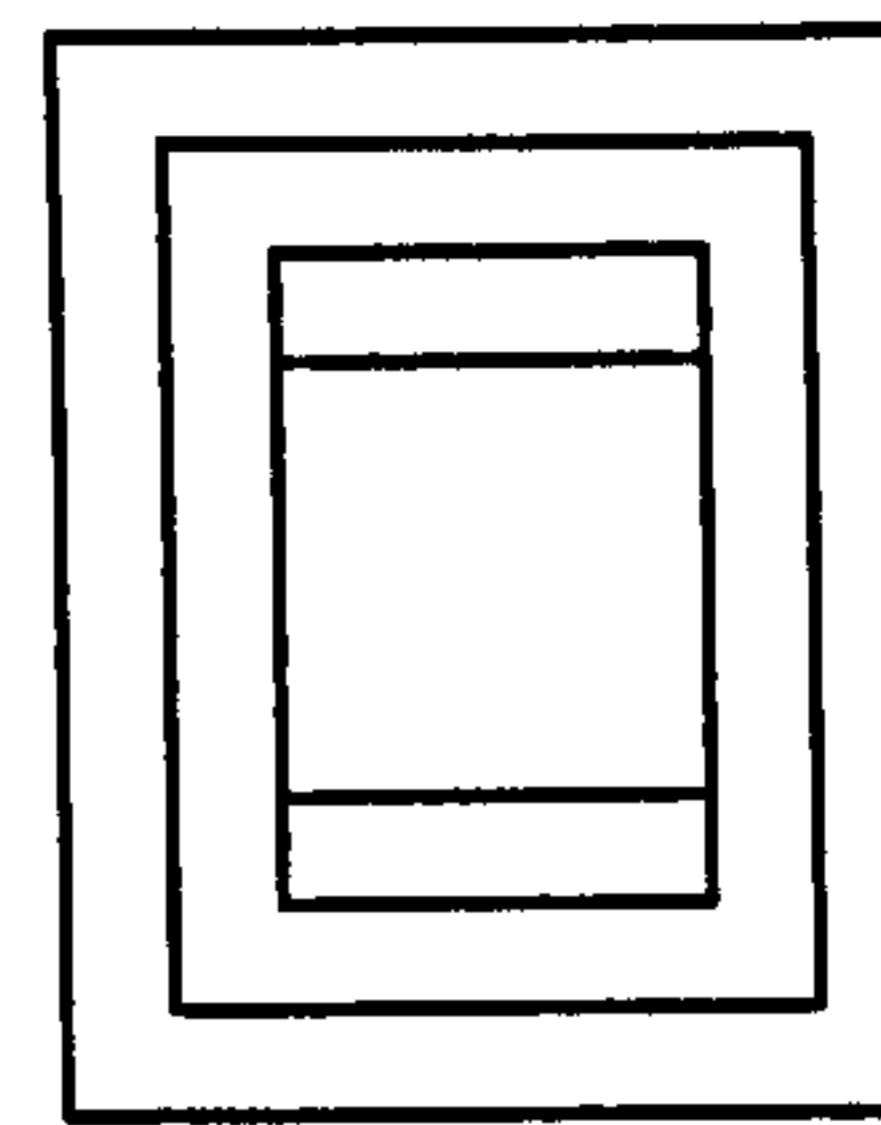

b

Dec 14

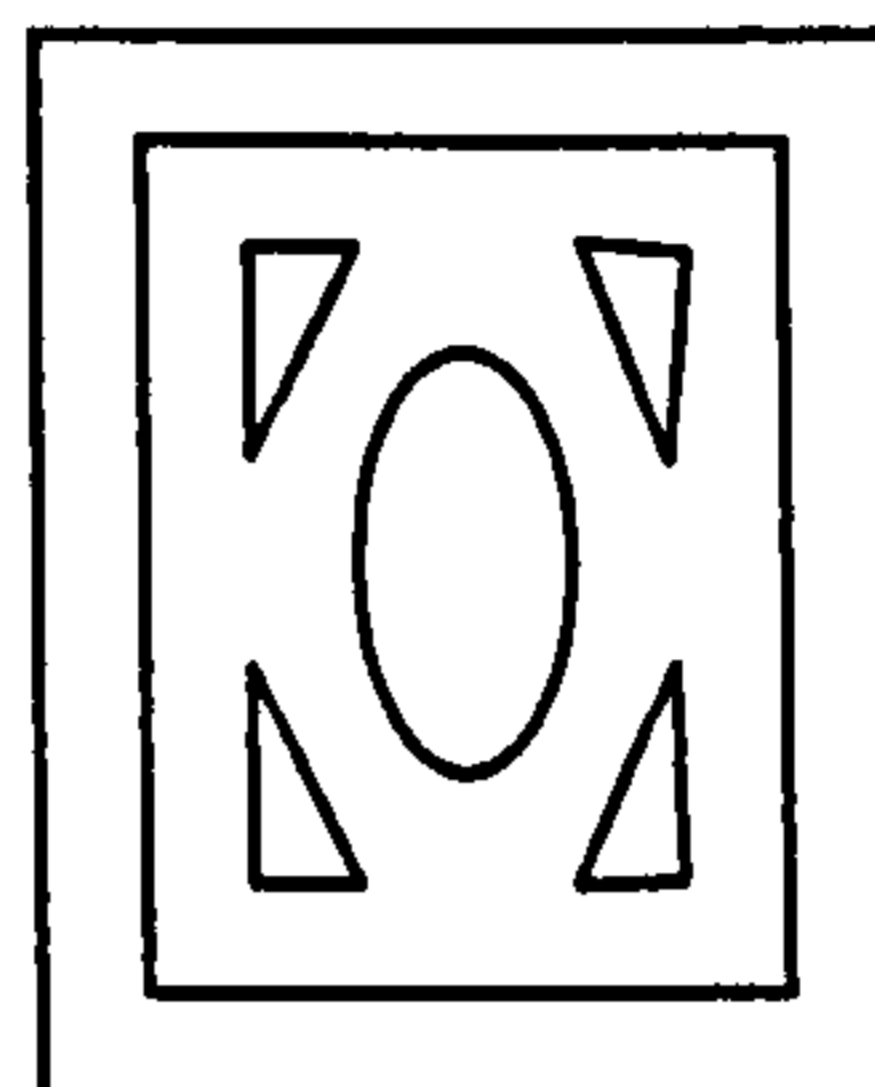
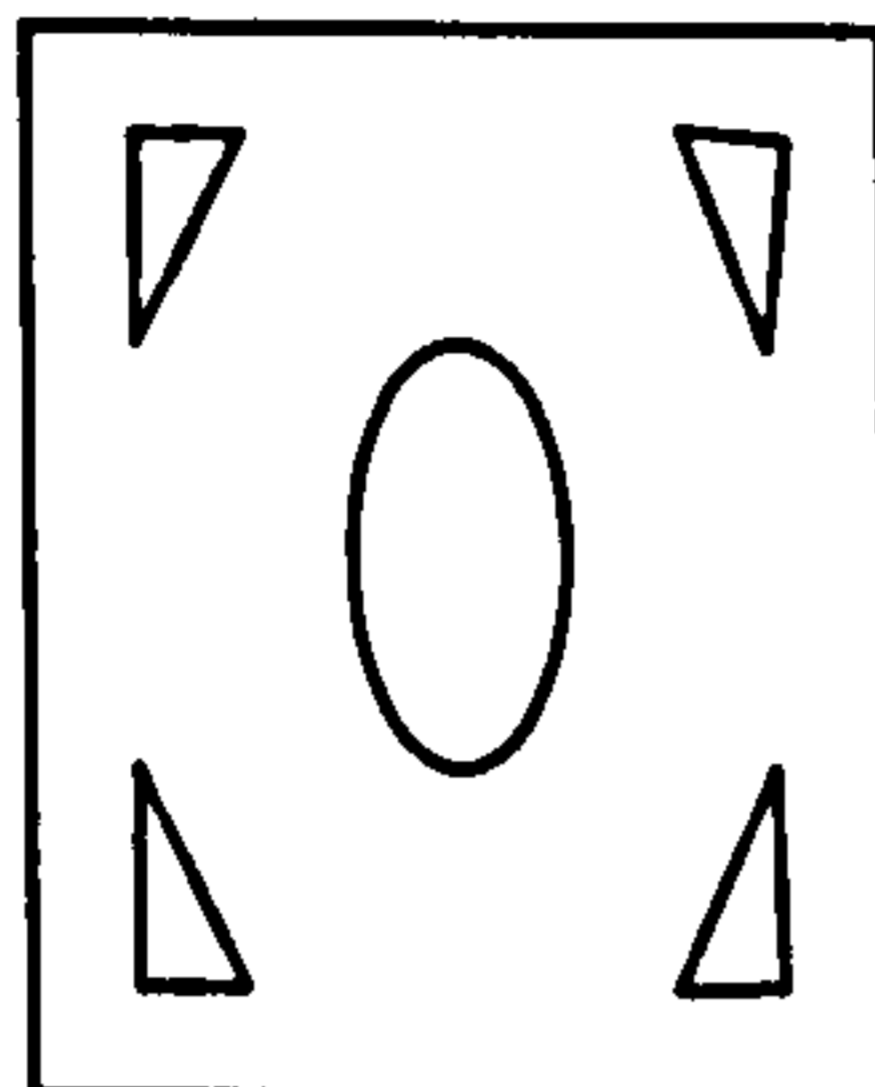

a

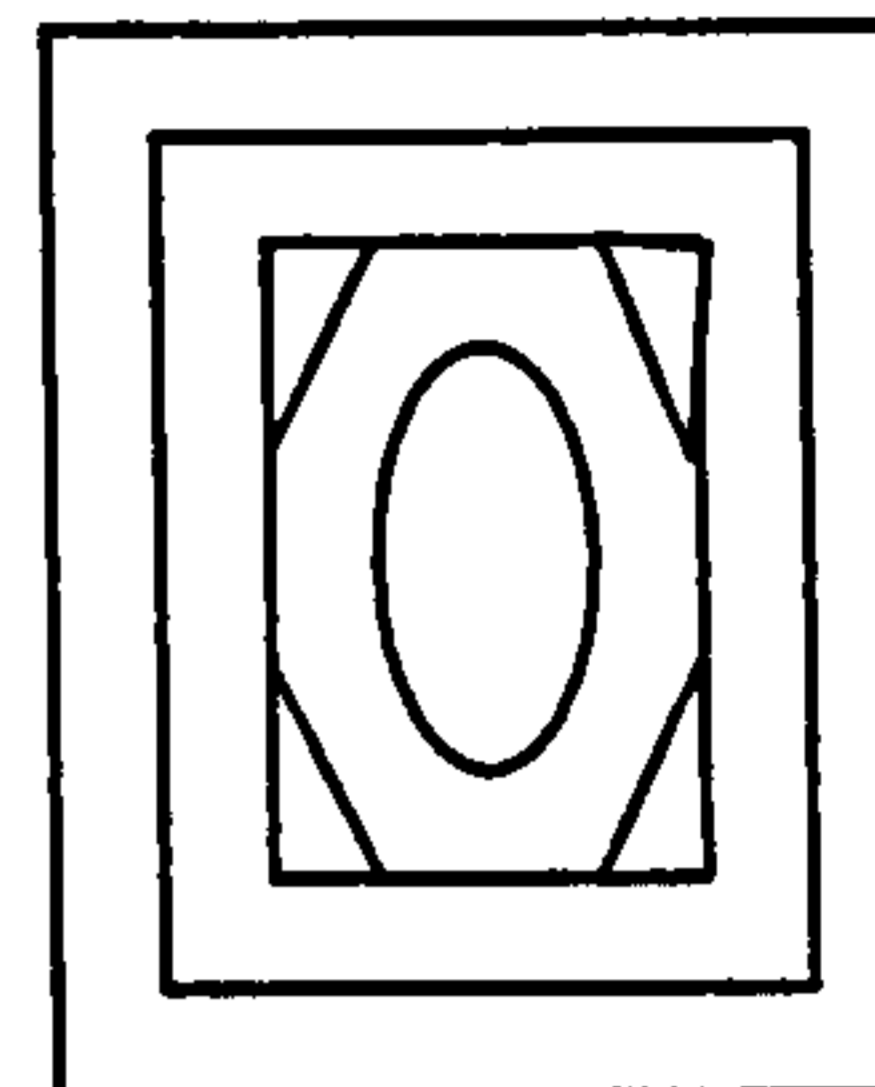

b

**Left / Right Board Decorative Pattern Difference [Yes/No]:** It refers to the decorative patterns and not to the tools used. ‘Yes’ if left and right boards have different decorative patterns, ‘No’ if they share the same decorative pattern even if there are some minor differences.

**Squares Decoration [Look-up Filed]:** indicates if there is any decoration in the boards squares.

None,

Gold tooled roll,

Blind tooled roll,

Blind tooled fillets.

**Board Edges Decoration Pattern [Look-up Field]:** indicates the type of any eventual decoration on the board edges. So far it refers to the Greek-style bindings only.

BED1,

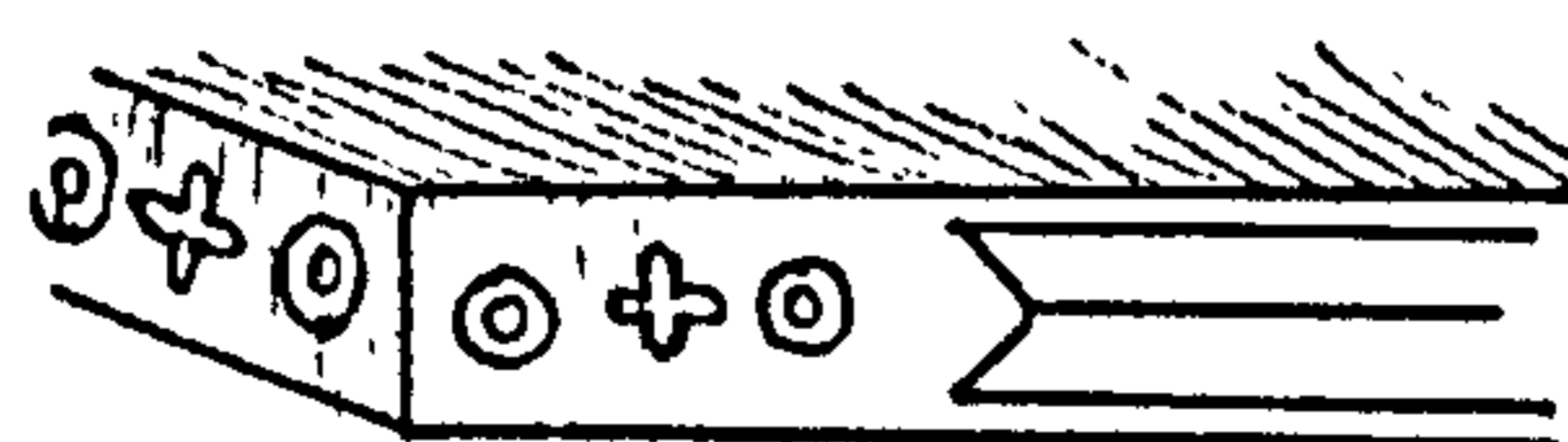

BED2,

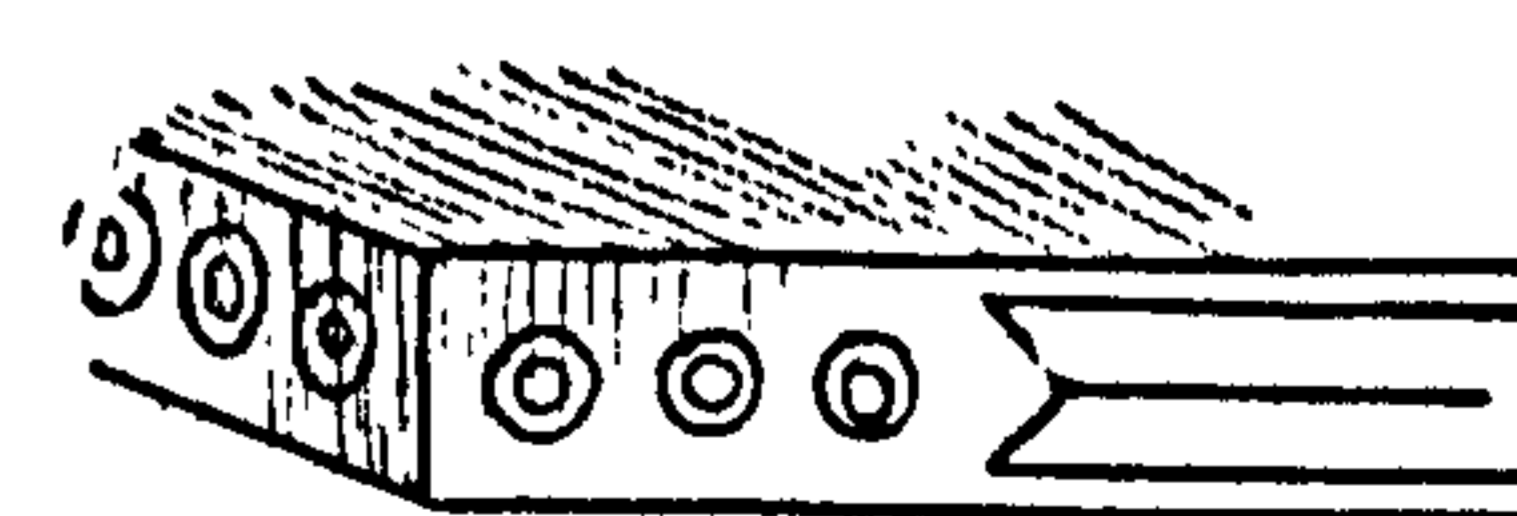

BED3,



BED4,



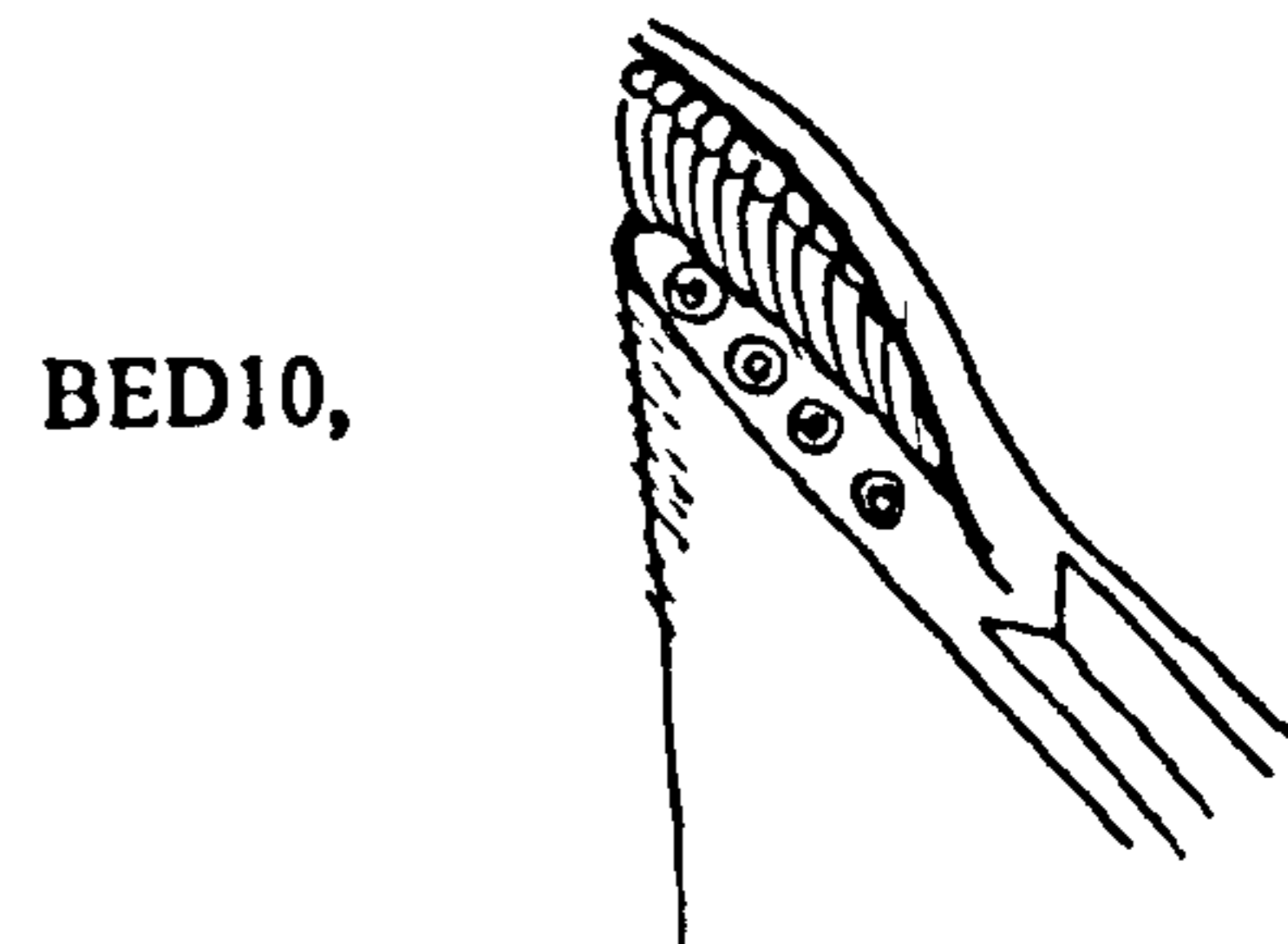
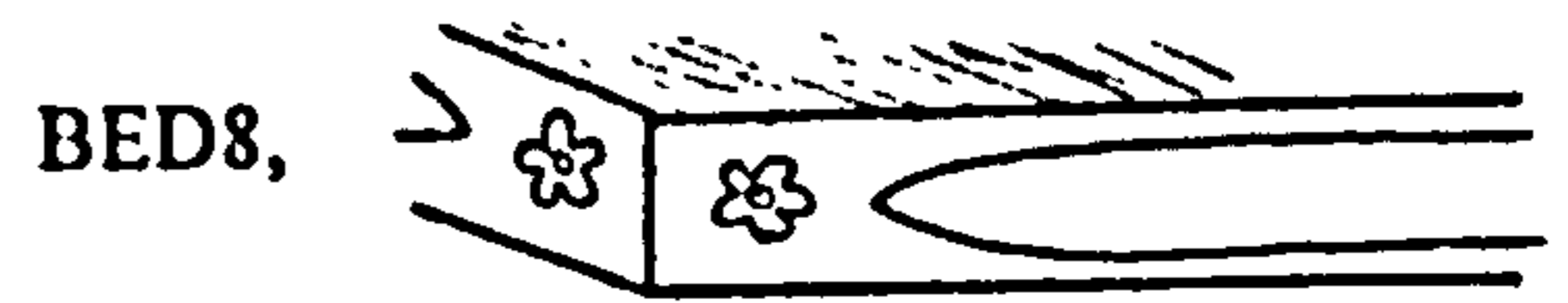
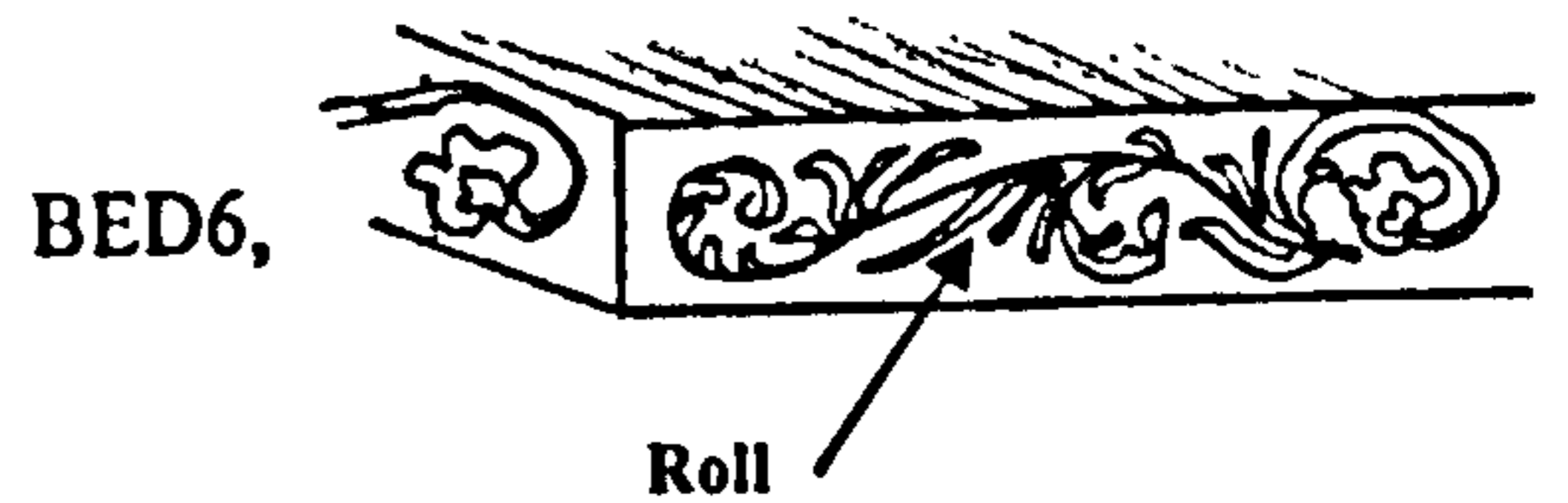
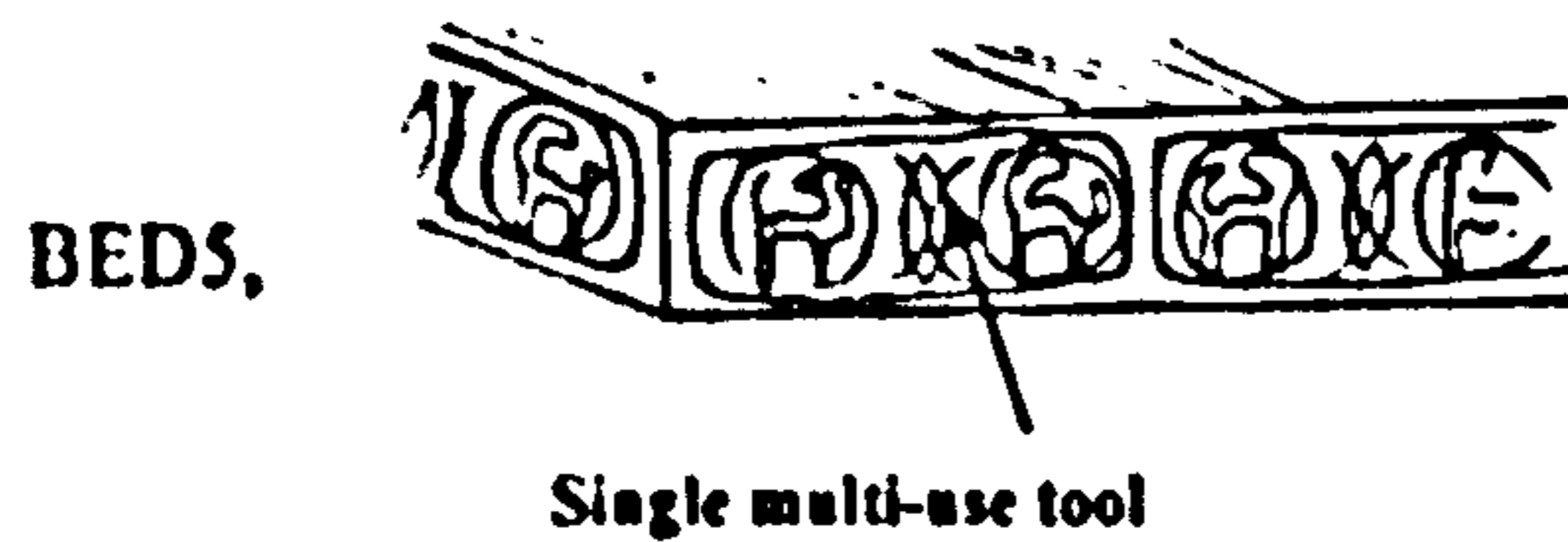

**Spine Decoration [Look-up Field]:** indicates if there is any decoration on the spine and its type.

No,

Yes,

Yes blind tooled single motif tools,

Yes blind tooled panel,

Yes blind tooled fillets,

Yes gold tooled single motif tools,

Yes gold tooled panel,

Yes gold tooled fillets.

**Spine Decoration Pattern [Look-up Field]:** refers to a standardized typology of the spine decoration. As in the aforementioned field describing the decoration of the covers, classification is based on the general decoration 'grid', made with fillets or occasionally creasers. On this general lay-out multi-use single tools may be found, though it was not possible to classify the various ways in which they are arranged. The only exception are patterns SD5



and SD6: the former indicates spine decoration which makes no use of fillets or creasers (small roundels are only indicative of the presence of tools), and the latter indicates the use of cornerpieces in each panel of the spine, though small multi-use tools may also be found in the lozenge spaces created. According to whether the tools are used in blind, gold or silver the letters B, G, and S are used respectively after a virgule (/) following the codified designation.

When the decoration of the spine cannot be satisfactorily described by this classification 'other' is recorded:

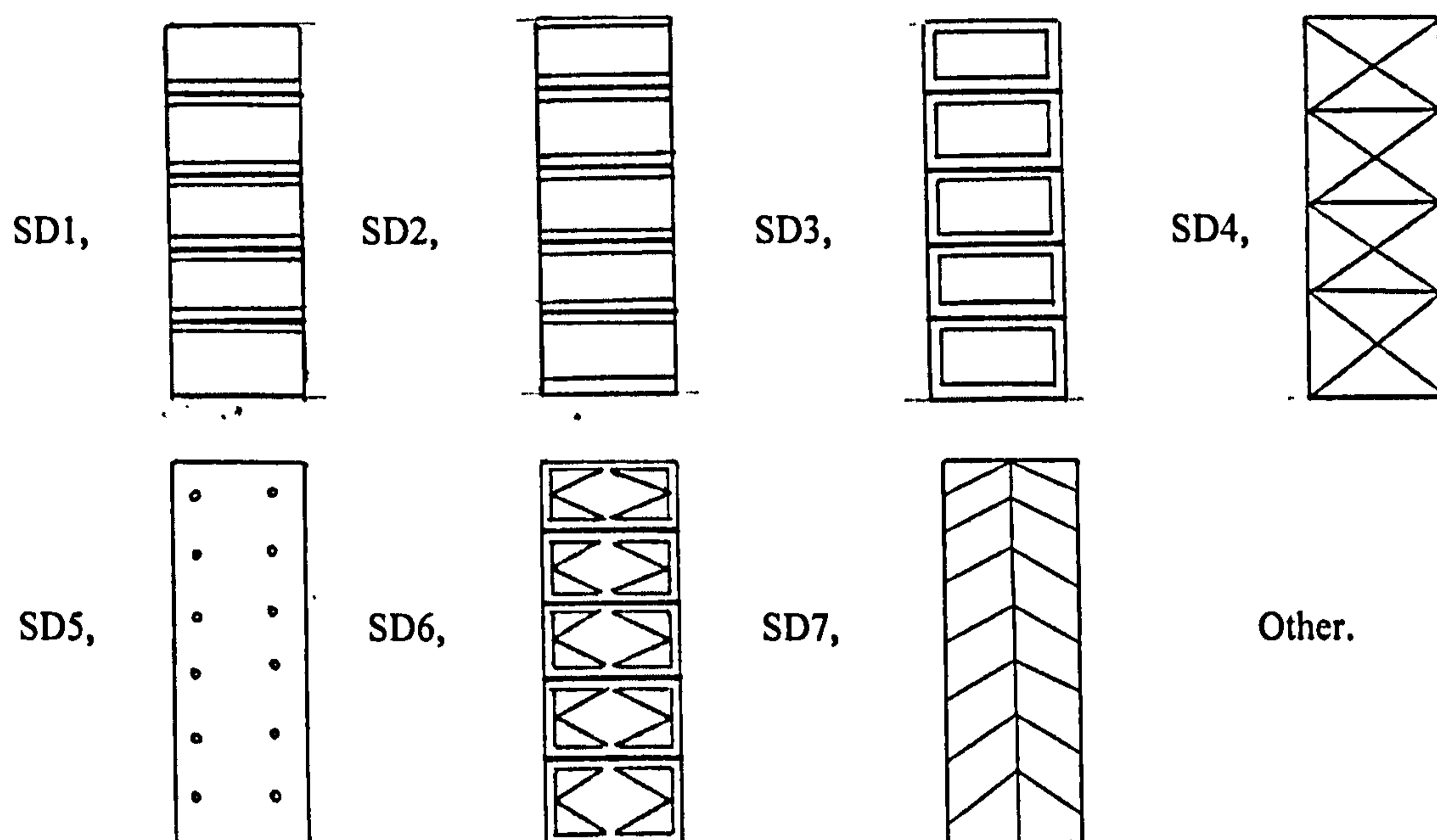

**Rubbings [Free-Text]:** refers to the serial number of rubbings taken from the books surveyed.

Rubbings will usually also include drawings of technical-structural or other features of the corresponding books that could not be recorded otherwise, or where their graphic record looks much more compressible than the written one.

**Tools [Free-Text]:** indicates the kind of tools used for the decoration of the cover. Tools are divided in: **single motif tools** (tools which contain one autonomous motif or scene), **rolls** (tools consisting of a metal wheel with the circumference engraved with a continuous repeating pattern which is

impressed on the leather as it revolves under pressure on its surface), **fillets** (tools consisting of a metal wheel with one or more raised bands on its circumference which are impressed on the leather as it revolves under pressure on its surface), **creasers** (curved metal tool having two or more lines on its face which is dragged under pressure so that the lines are impressed on the leather), **panel stamps** (a tool which consists of a relatively large metal block containing a full decorative pattern, which may in its turn include various smaller motifs and patterns, which is tooled on the boards covering the whole or most of its surface) or any combination of these.

**Decoration Motifs [Free-Text]:** refers to the serial number of the decoration tools used.

Tools have been classified according firstly on the type of tool ( Multi-use single tools, Rolls, Centre pieces, Corner pieces and Uncertain or Unidentified). Each group was further divided in subgroups according to the subject and each subject of each group in more restricted groups. In corner-pieces, where normally two reversed versions of the same tool are necessary, only one of the two has been cataloged unless they are of a religious subject, in which case normally all four are different, and therefore all four are given a catalogue number. In this way the following categories and groups of tools have been created:

### MULTI-USE SINGLE TOOLS (Mu)

1. Floral (MuF)
  - a) Daisy-like Flower motifs (MuF/a)
  - b) Flower stem motifs (MuF/b)
  - c) Fleur-de-lis motifs (MuF/c)
  - d) Repeating motifs MuF/d)
  - e) Other (MuF/f)
2. Animal (MuA)
  - a) Eagle/ bird (MuA/a)
  - b) Quadruped (MuA/b)
  - c) Dragon (MuA/c)
3. Geometric (MuG)
  - a) Ring (MuG/a)

- |            |                      |         |
|------------|----------------------|---------|
|            | b) Interlaced motifs | (MuG/b) |
|            | c) Other             | (MuG/c) |
| 4. Various |                      | (MuV)   |

#### ROLLS (Ro)

- |              |  |       |
|--------------|--|-------|
| 1. Floral    |  | (RoF) |
| 2. Geometric |  | (RoG) |

#### CENTRE PIECES (Ce)

- |              |  |       |
|--------------|--|-------|
| 1. Floral    |  | (CeF) |
| 2. Religious |  | (CeR) |

#### CORNER PIECES (Co)

- |              |  |       |
|--------------|--|-------|
| 1. Floral    |  | (CoF) |
| 2. Religious |  | (CoR) |

#### CREASERS

Each tool is numbered independently inside its own tool and subject category. The serial number of each tool follows the code of its category. For example MuG/b2 is the second tool of the

Multi-use single tools (for **Mu**)>Geometric (for **G**)> interlaced motif group (for **b**).

MuF/a49 is the tool number 49 of the

Multi-use single tools (for **Mu**)> Floral (for **F**)> Daisy-like flower motif group (for **a**).

CeR12 is the tool number 12 of the

Centerpieces (for **Ce**) > Religious subject group (for **R**).

**Kind of Metal Fittings [Look-up Field]:** indicates the kind of any metal furniture attached on the binding's boards:

- None,
- Missing,
- Board edge nails,

Bosses,  
 Bas-relief plaques,  
 Engraved plaques.

**Type of Metal Fittings** [Look-up Filed]: indicates the types of the metal fittings. Historical terms have been used as they are explained and established by B. Atsalos (B. Atsalos 1977). Therefore *Gammatia* is the term used to indicate the Γ-shape metal fittings often nailed on the four corners of the boards, *Amigdalia*, the term used to indicate the almond or hard-shape metal fittings also normally nailed in the corners of the boards. The term *Boullai*, is used to indicate any round-shaped metal fitting or boss nailed on the boards, though not exclusively in the corners but also, normally in the center of the boards. In the case of metal plaques, the subject is recorded.

Amigdalia,  
 Gammatia,  
 Boullai  
 Cross,  
 Crucifixion

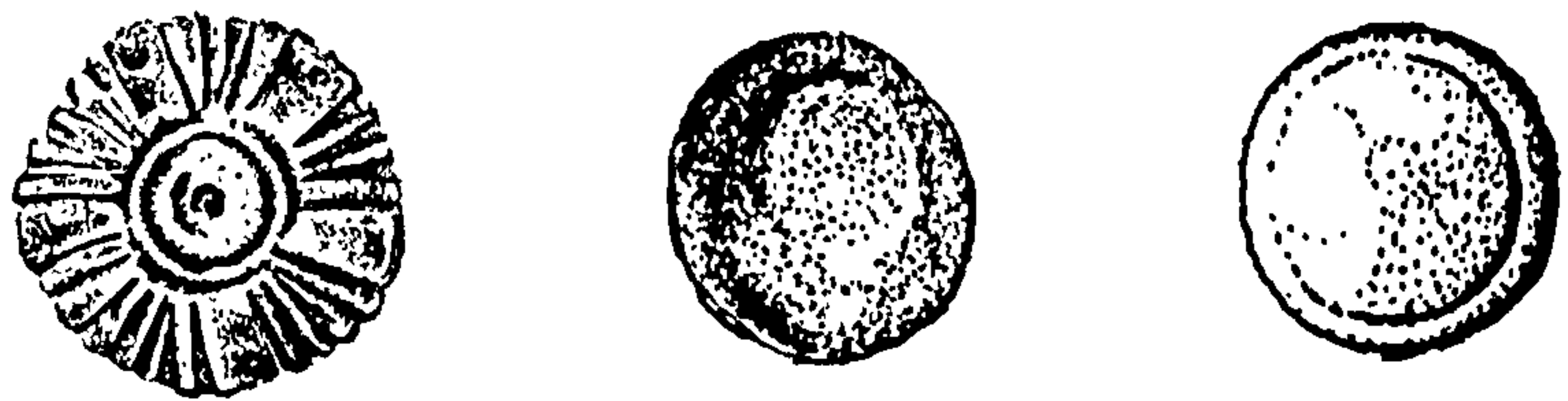

Three different types of *boullai* as recorded on bindings examined in the research



A *gammatio* after Szirmai (1999 fig. 6.16.)

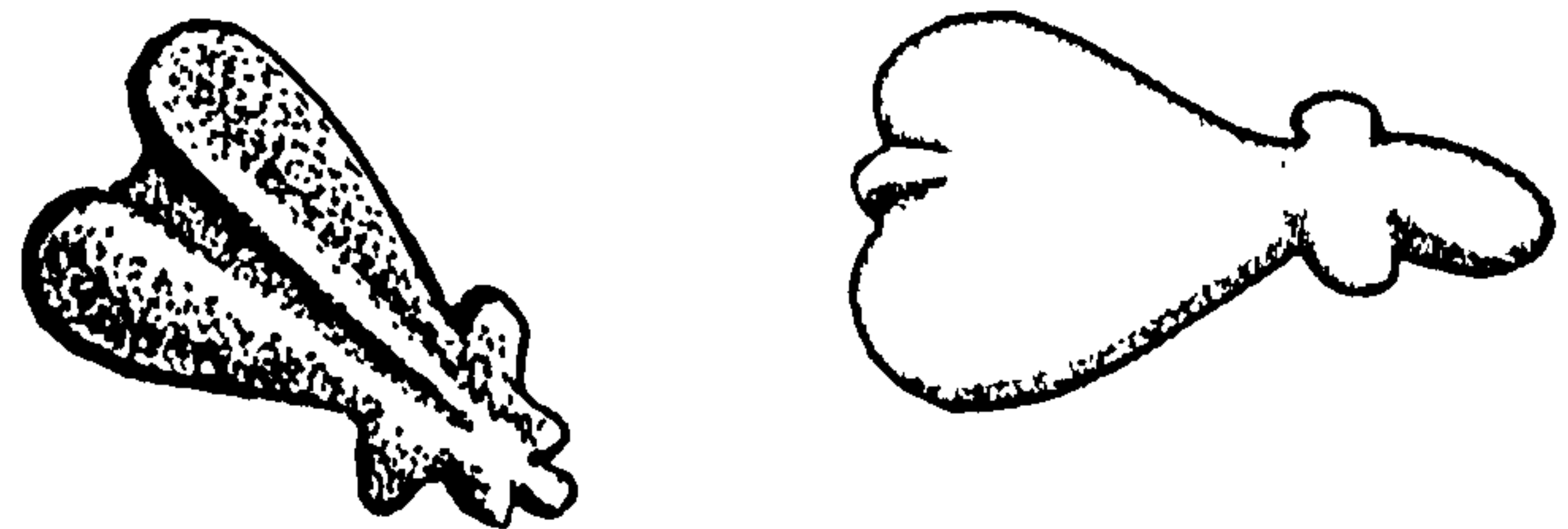

Two different types of *amigdalia* as recorded on bindings of the research.

**Number of Fittings** [Free Text]: indicates the total number of furniture originally attached to the binding as they can be seen on it or deduced from holes, colour marks on the cover etc.

The indication L and R is used to separate the furniture of the left cover from those of the right cover. For example L5(-2), R5 means that originally there were five metal furniture on the left board of which two are now missing and five in the right board, all of them still preserved.

**Metal [Look-up Field]:** indicates the kind of metal used for the metal furniture of the binding whenever identifiable through visual observation.

Copper alloy,

Lead,

Silver gilt

Silver,

**Attachment Method [Look-up Field]:** indicates the method used for the attachment of the metal furniture on the boards of the book and their relation to the pastedowns, since this can offer some hints regarding the attribution of metal fittings and/or the pastedowns to the original binding or to a latter intervention.

Nailed, ends underneath pastedown

Nailed, ends flattened above pastedown,

Nailed, ends flattened underneath pastedown,

N. v.

**FASTENINGS AND MARKERS INFORMATION** includes the following fields:

**Fastenings Type [Look-up Field]:** indicates the type of fastenings if any.

None,

Three ends silk braided strap, pin and ring,

Two ends leather interlaced straps, pin and ring / standard type (A),

Three ends leather interlaced straps, pin and ring/ long hinge (B),

Three ends leather interlaced straps, pin and ring / standard type (C),

Three ends leather interlaced strap, pin & ring / N. K. (when only vestiges survive which do not permit any firm identification of the precise type ),

Three ends leather straps, pierced (D),

Two ends leather strap, pierced (E),

Single end leather strap,

Two ends leather strap, ring and pin (F),

Three ends leather strap, ring and pin (G),

Hook and Catch plate (H),

Holed metal sheet and Pin (I),

Two ends leather Turk's head knot and interlaced loop (J),

Leather straps (K),

Textile woven ribbon,

Silk ties.

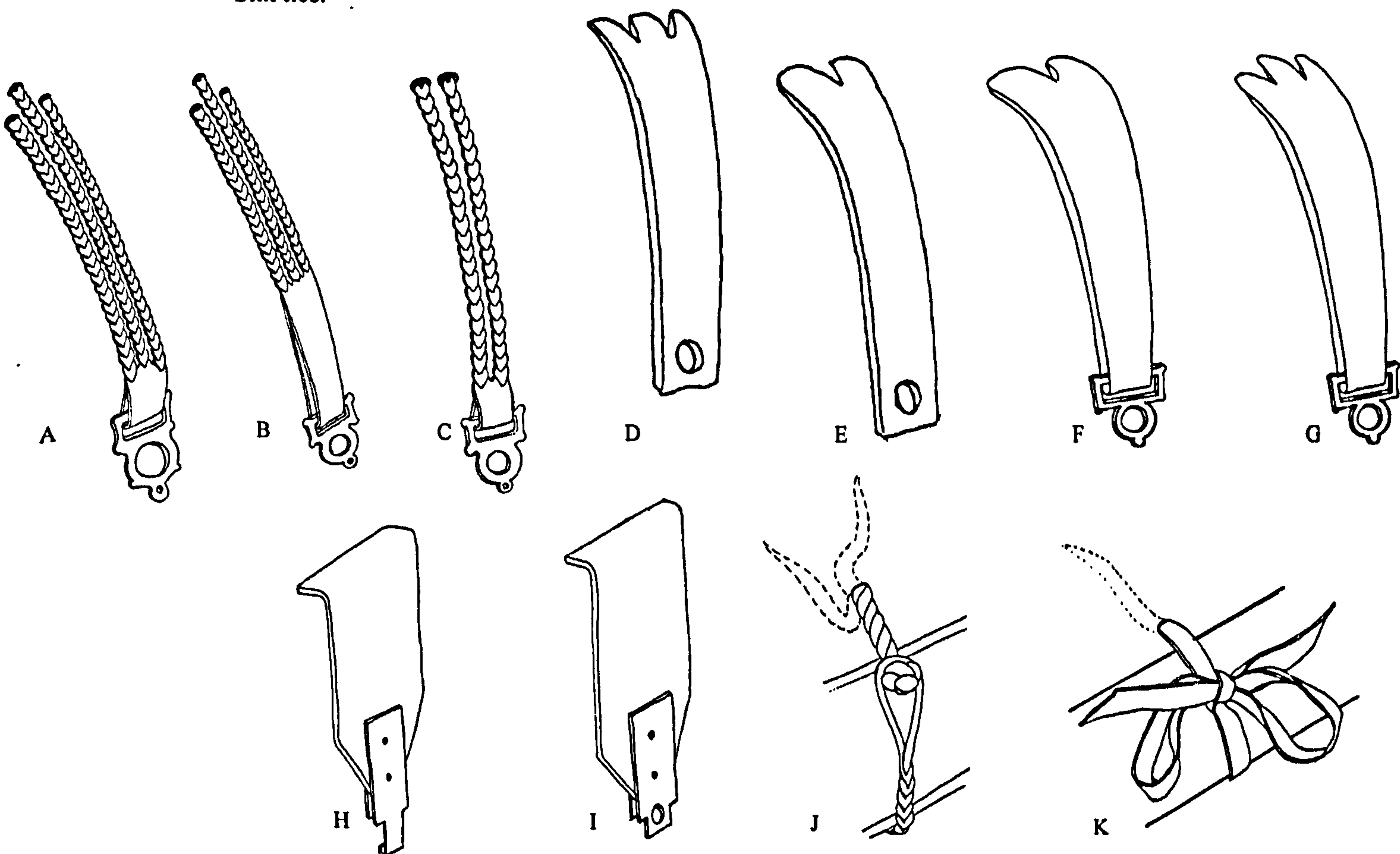
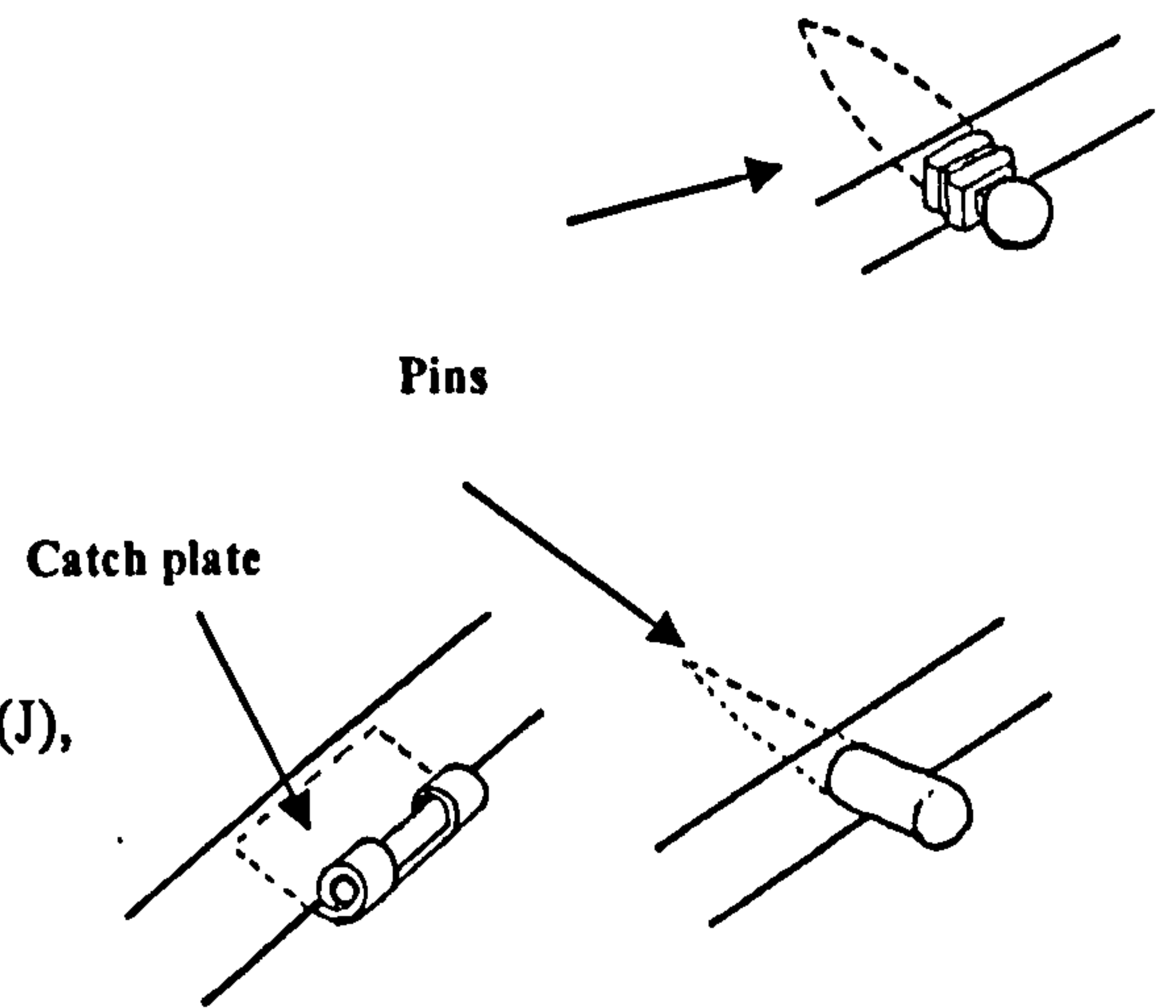

**Strap Type [Look-up Field]:** indicates the type of the leather strap in 'Hook and pin' and 'Hook and catch plate' fastenings:

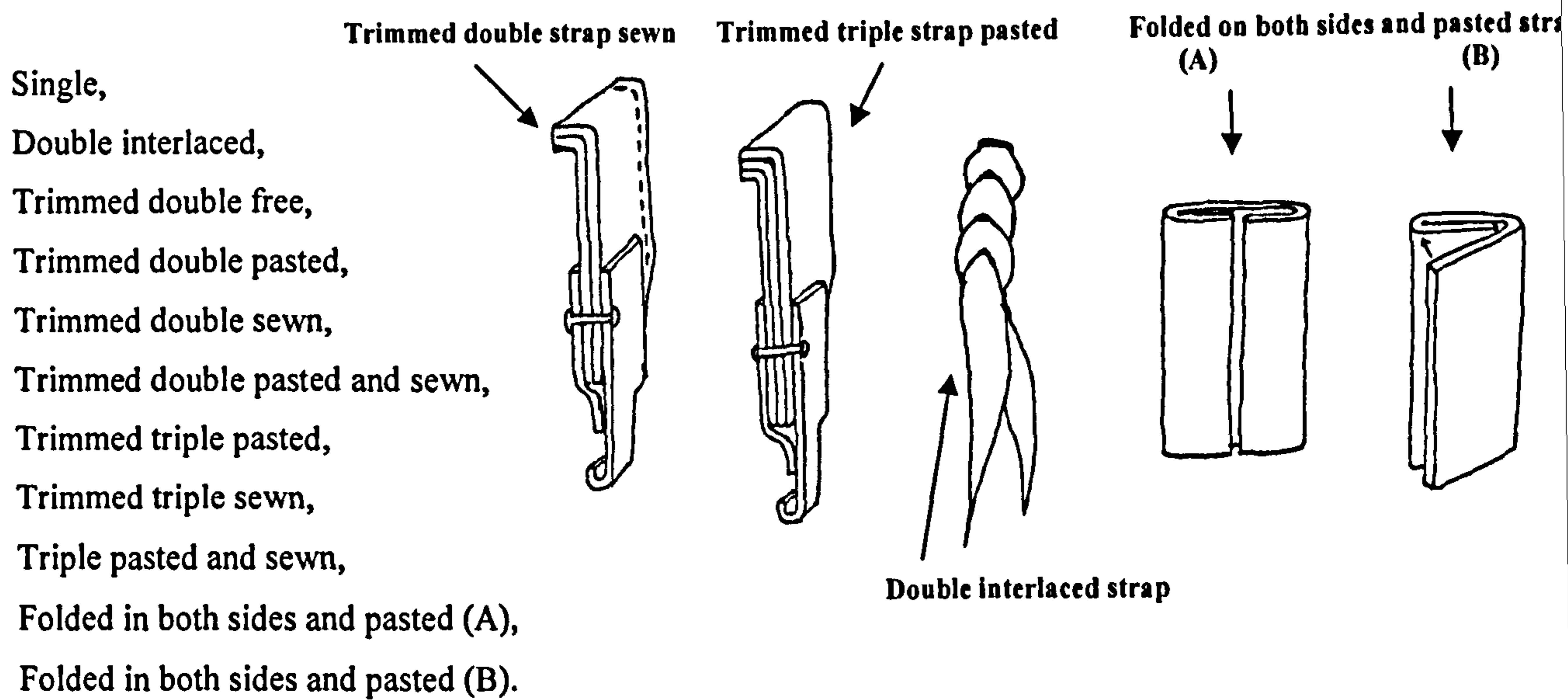

**Fastenings Material [Look-up Field]:** indicates the material used for the construction of the fastening. If the leather of the straps is different from that of the cover but still identifiable then the animal species should be recorded.

- Same as the one used for the cover, (S.a.C.),
- Same as the one used for the cover and metal, (S.a.C. and metal),
- Different than the one used for the cover, (D.t.C.),
- Different than the one used for the cover and metal, (D.t.C. and metal)
- Silk,
- Silk and metal,
- Linen,
- Cotton.

**Strap Colour [Free text]:** if the colour of the fastenings is identical with that of the cover then only 'S. a. C.' should be recorded, otherwise its actual colour/s.

**Strap Decoration [Look-up Field]:** indicates the type of decoration of the straps if any:

- None,
- Blind tooled fillets,
- Blind tooled rolls,

Blind tooled single tools,  
 Blind tooled fillets and single multi-use tools,  
 Blind tooled fillets, rolls and single multi-use tools,  
 Gold tooled fillets,  
 Gold tooled rolls,  
 Gold tooled single tools,  
 Gold tooled fillets and single multi-use tools,  
 Gold tooled fillets, rolls single multi-use tools

**Hook Type [Look-up Field]:** indicates the general type of the hook in “Hook & Catch plate” type fastenings (the drawing is only indicative since variation is very high):

Sheet metal folded, SMF  
 Sheet metal engraved, SME  
 Sheet metal, indented edges, SMiE  
 Sheet metal engraved, indented edges SMEiE  
 Cast metal engraved, CME  
 Cast metal, engraved and beveled edges, CMEbE  
 Cast metal, engraved and indented edges, CMEiE  
 Cast metal, engraved, indented and beveled edges. CMEibE

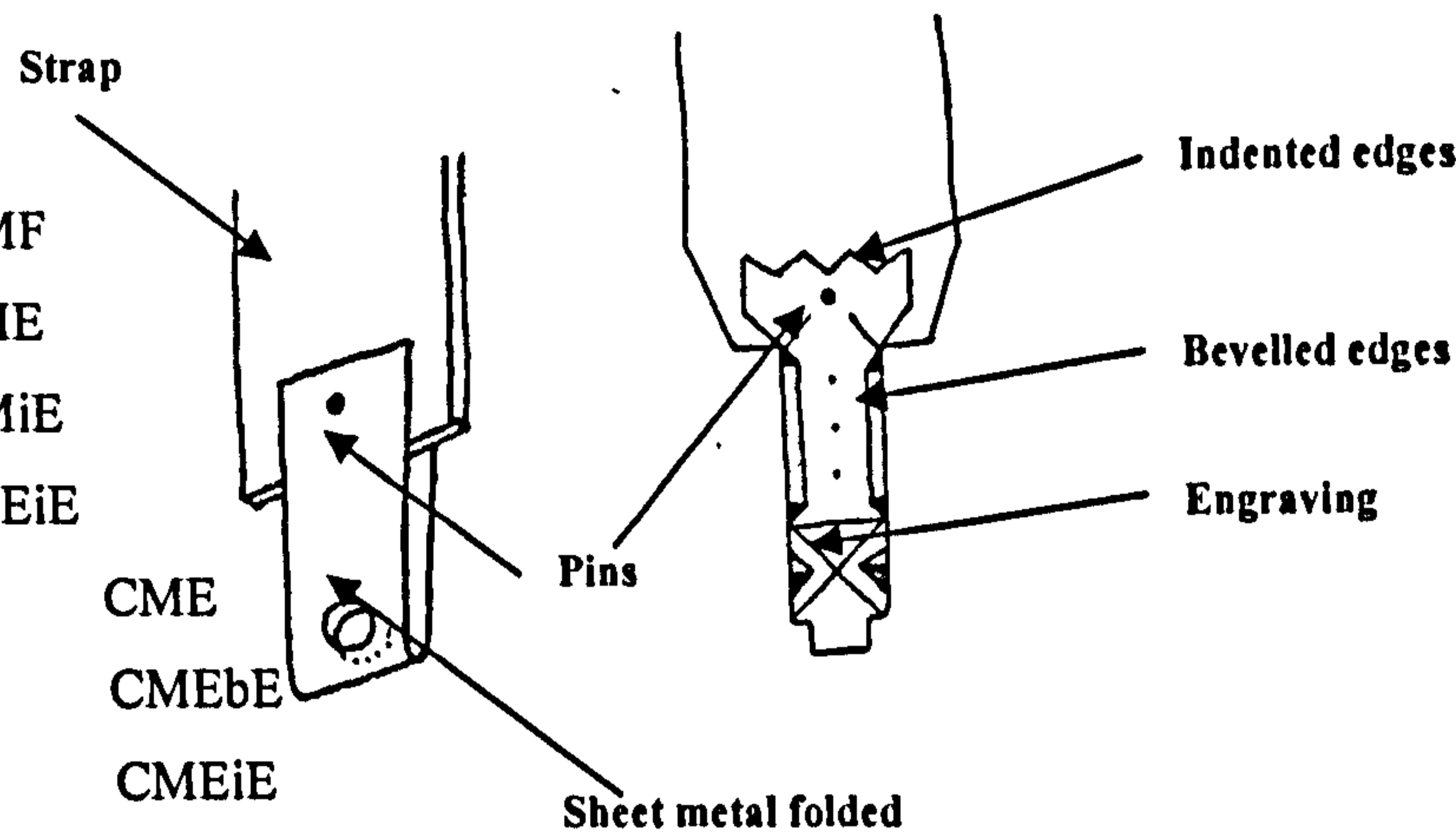

**Hook & Strap Attachment System [Look-up Field]:** indicates the method of construction of the hook and the number of rivets used to attach the hook to the leather strap in “Hook and Catch plate” and ‘Hook and Pin’ fastenings:

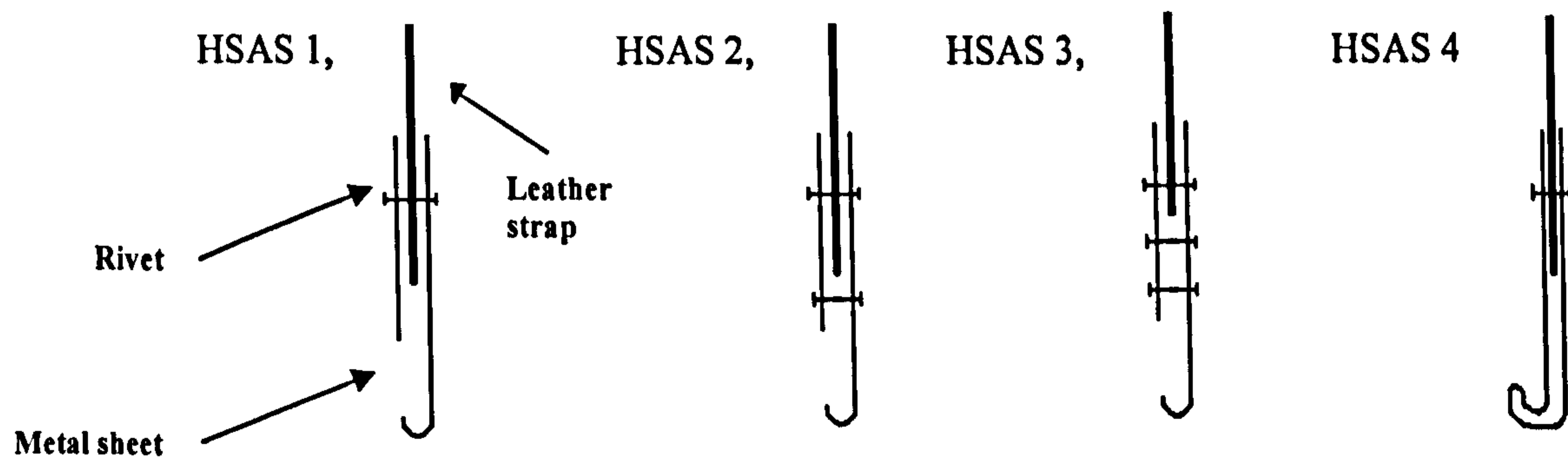

**Catch Plate Type [Look-up Field]:** indicates the type of the catch plate in ‘Hook & Catch plate’ fastenings. ‘Internal’ indicates that the anchor plate is inserted between the board and the cover through a slot and ‘external’ indicates that the anchor plate is nailed above the cover. For the terms ‘engraved’ and ‘bevelled edges’ see ‘Hook type’ field above.



Thin metal sheet with slot,	TnMSwS (A)
Thin metal sheet engraved with slot,	TnMSEwS
Thin metal sheet indented edges, engraved with slot,	TnMSIEEwS
Thin metal sheet with bar,	TnMSwB (B)
Thin metal sheet, indented edges with bar,	TnMSIEwB
Thin metal sheet, indented edges, engraved with bar,	TnMSIEEwB
Thick metal sheet with slot,	TkMSwS
Thick metal sheet, engraved with slot,	TkMSEwS
Thick metal sheet with bar,	TkMSwB
Thick metal sheet engraved with bar,	TkMSEwB
Thick metal sheet, beveled edges with bar,	TkMSBEwB
Thick metal sheet engraved, beveled edges with bar.	TkMSEBEwB

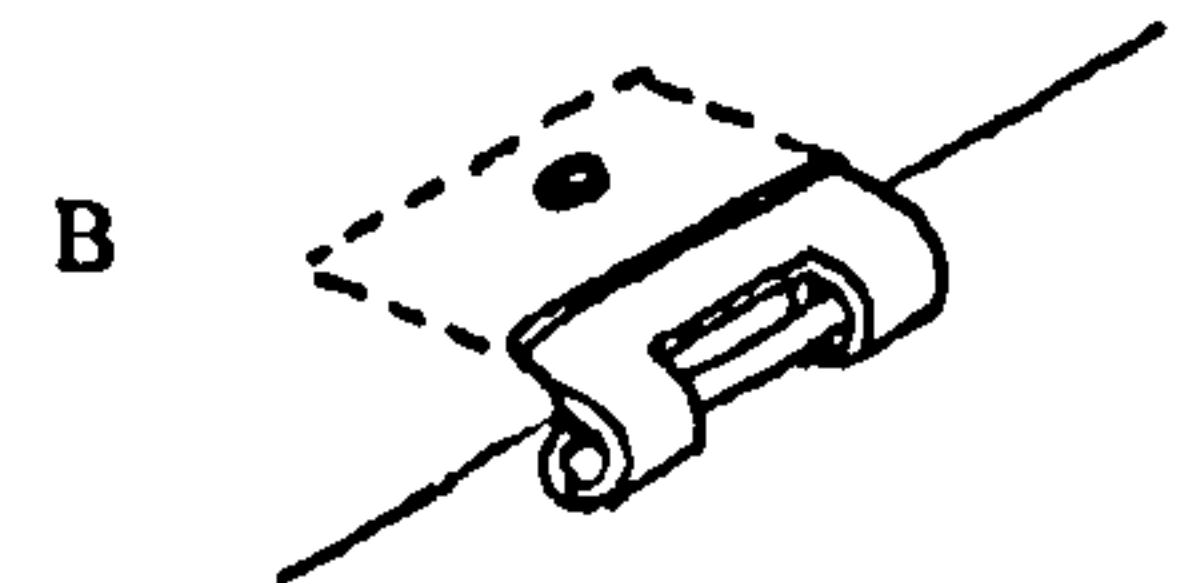
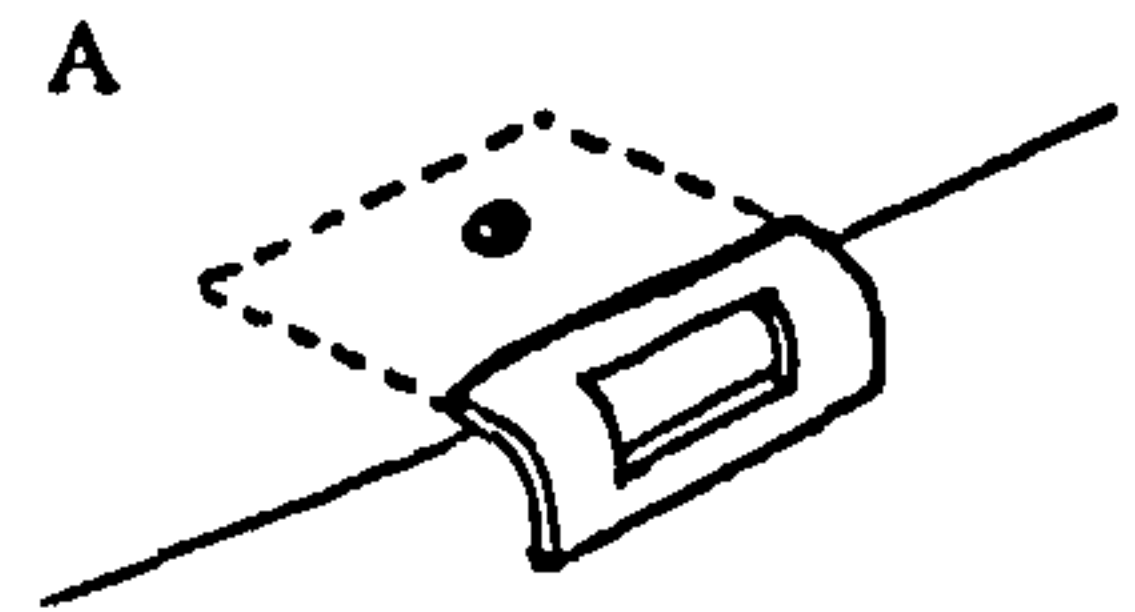

**Catch plate attachment system [Look-up Field]:** indicates the way the catch plate is attached onto the boards. 'CP' is for catch plate in order not to be confused with the straps attachment system:

Nailed above cover, 1 nail	NaC1
Nailed above cover, 2 nails	NaC2
Nailed above cover, more nails	NaC3
Nailed above cover with anchor plate	NaCAP
Nailed underneath cover, 1 nail	NuC1
Nailed underneath cover, 2 nails	NuC2
Nailed underneath cover, more nails	NuC3
Nailed underneath cover with anchor plate	NuCAP
Stapled above cover	SaC
Stapled underneath cover	SuC

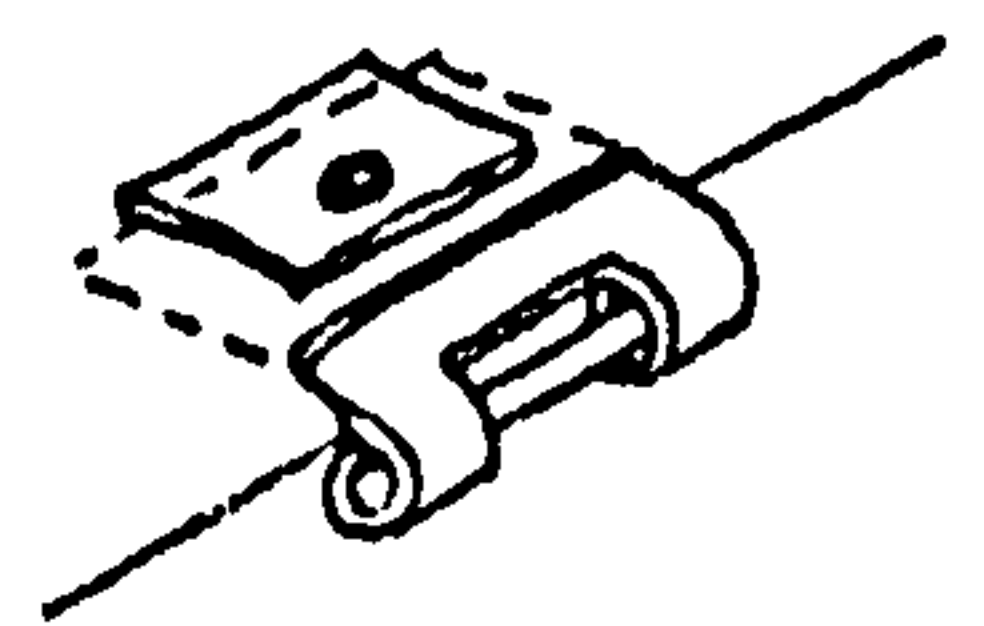

**Catch plate nailed underneath cover with anchor plate**

**Anchor plate of the Catch plate [Look-up Field]:** Indicates the type of any anchor plate that may be used in order to anchor the catch plate of the fastenings on the boards:

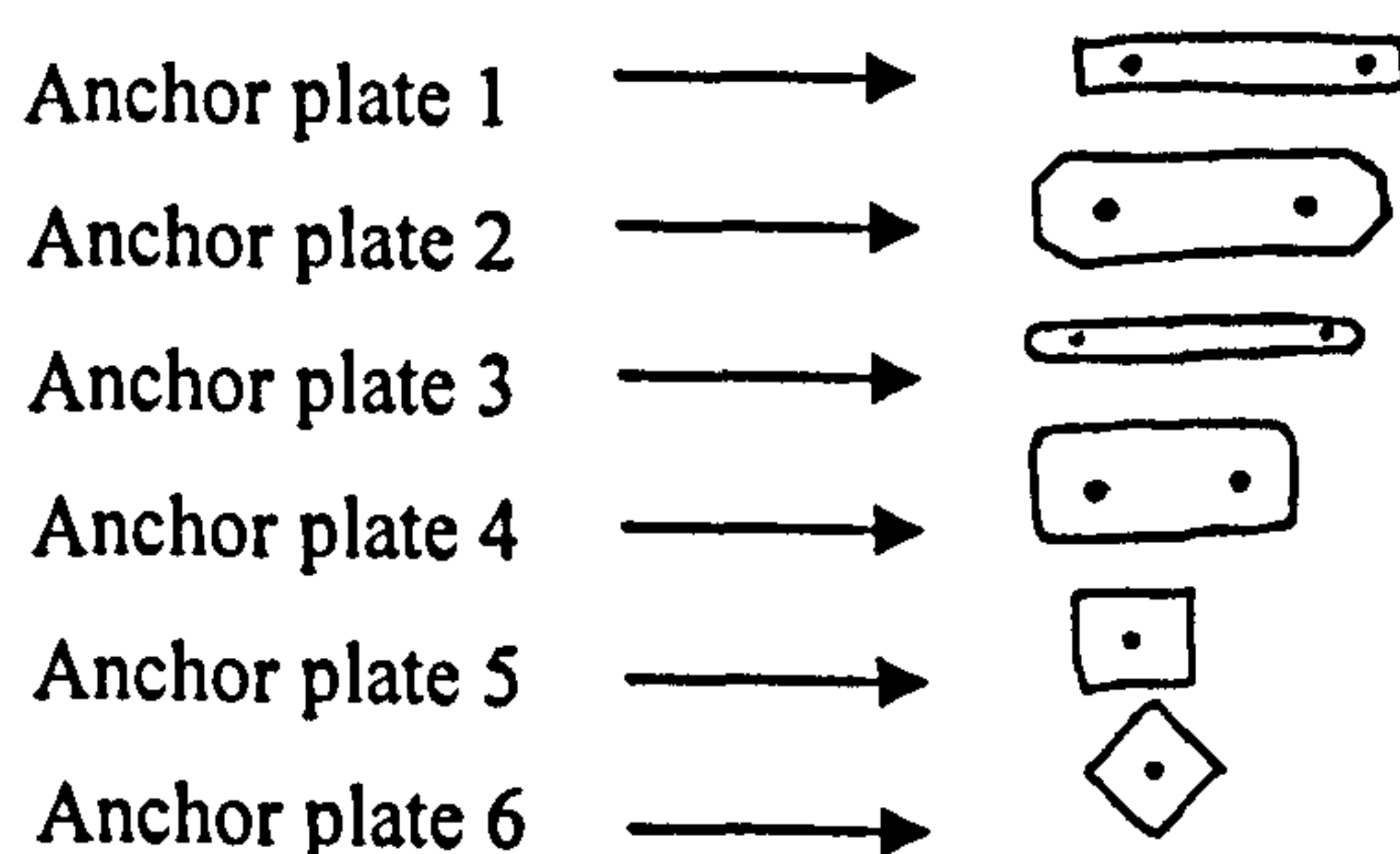

Anchor plate any other shape

**Pin Type [Free Text]:** indicates the material and the method of construction of the pin. ‘Compound’ is to indicate that the pin is composed of two parts, normally a base and a rounded edge. In these pins, when the fastening is used, the ring of the strap is normally jammed between the base and the rounded edge. ‘Filed’ is used to indicate that there are file marks of the surface of the pin though their presence can not exclude that primarily the pin might have been cast and then finished with a file. Nevertheless ‘cast’ is normally used to describe elaborate pins as opposed to filed ones which are normally very plain and simple. Pins in the context of the present research are always nailed on the edges of boards. The following variations have been recorded. :

- Cast metal simple,
- Cast metal compound,
- Cast metal compound and secured,
- Filed metal simple,
- Filed metal compound,
- Filed metal compound and secured,
- Cast and filed metal compound,
- Wood simple,
- Bone simple.

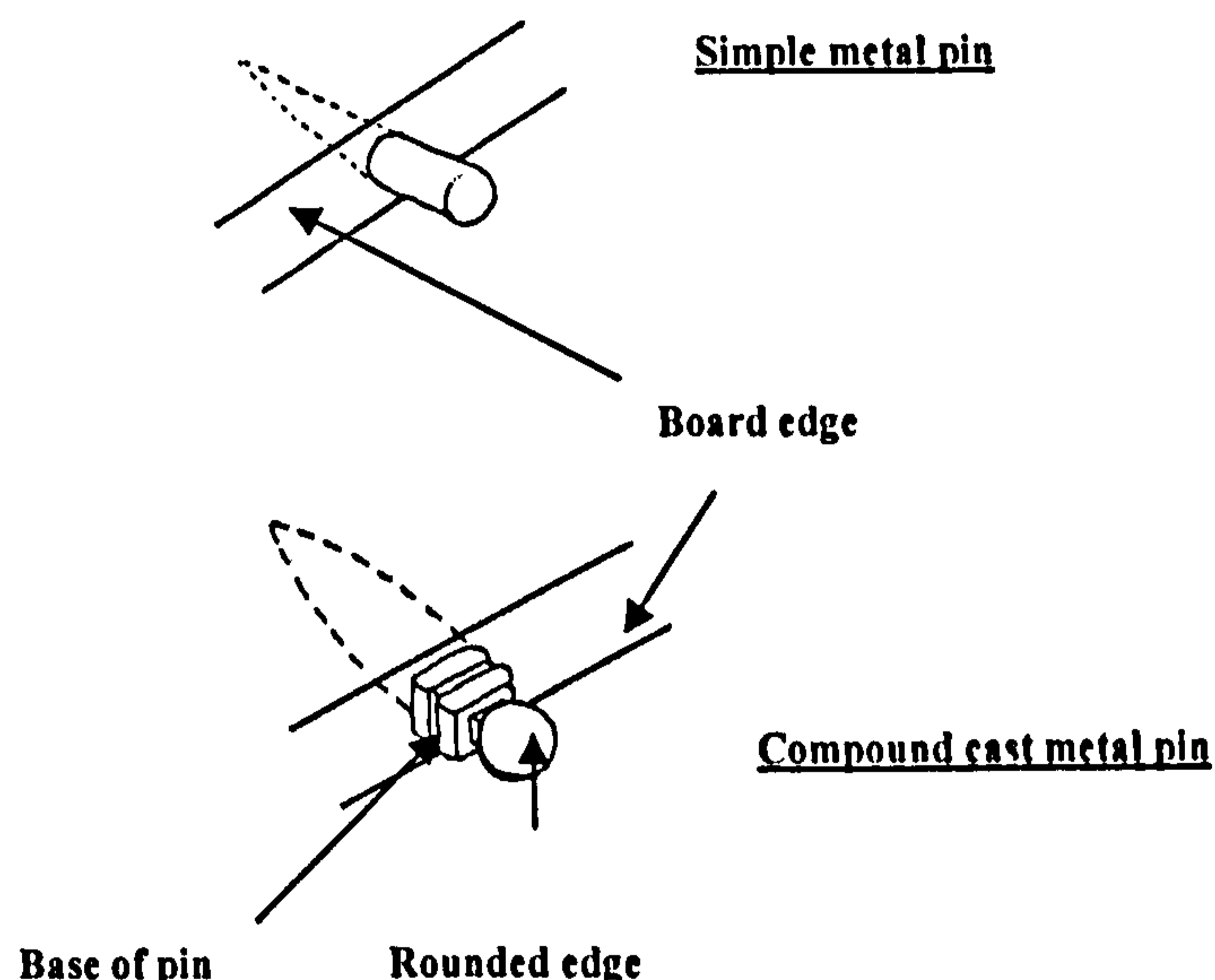

**Number of Fastenings (bottom, fore, top edge ) [Free Text]:** Indicates the number of fastenings starting from the bottom edge, fore edge and top edge. Thus the formula 0-2-0 means that there are two fastenings both placed in the fore edge and none on the top and bottom edges.

**Arrangement of Anchorage Holes:** refers to a codified list of the possible disposition of the anchorage holes or slits in the case that the fastening are of the ‘Leather braid and metal’, “Leather Straps” and “Textile Ribbon” types.

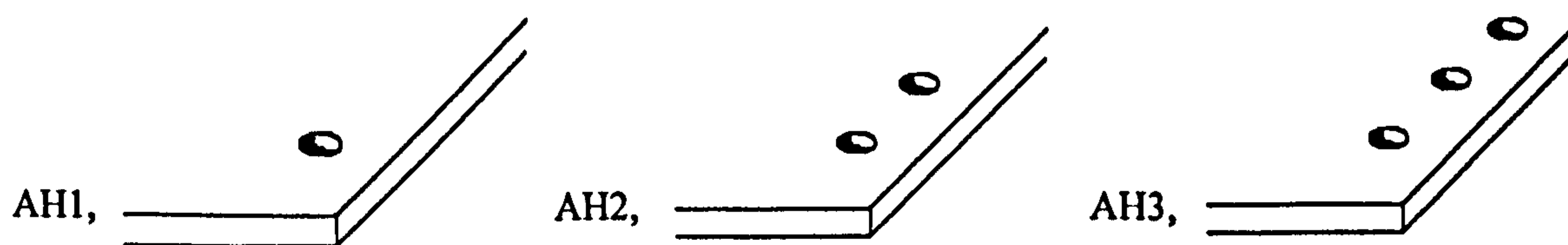

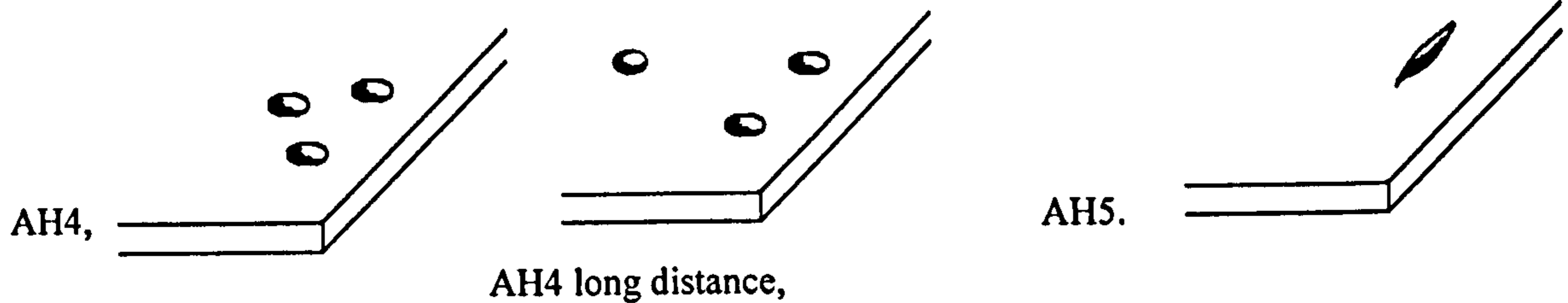

**Strap Anchorage Type [Look-up Field]:** indicates the type of anchorage of the fastenings.

- Traverse boards,
- Traverse boards and turn-ins,
- Traverse boards turn-ins pastedowns,
- Traverse boards and pastedowns,
- Nailed underneath cover, 1 nail,
- Nailed underneath cover, 2 nails,
- Nailed underneath cover with anchor plate,
- Stapled underneath cover.

- (TB)
- (TBT)
- (TBTP)
- (TBP)
- (NuC1)
- (NuC2)
- (NuCAP)
- (SuC)

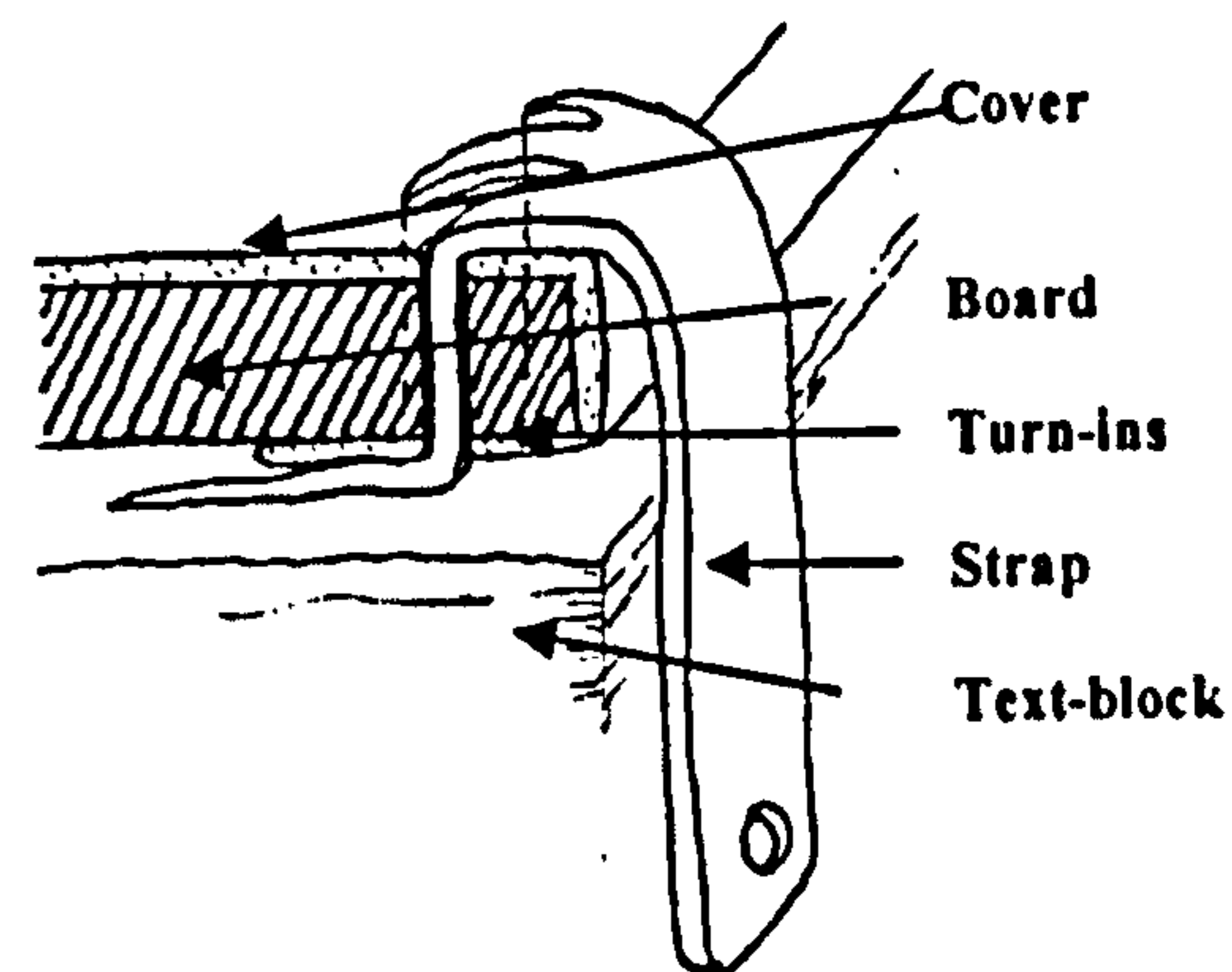

**Anchor Plate of the Strap [Look-up Filed]:** Indicates the type of any anchor plate that may be used in order to anchor the catch plate of the fastenings on the boards:

- Anchor plate 1 →
- Anchor plate 2 →
- Anchor plate 3 →
- Anchor plate 4 →
- Anchor plate 5 →
- Anchor plate 6 →
- Anchor plate any other shape

Fastening strap nailed underneath cover with anchor plate

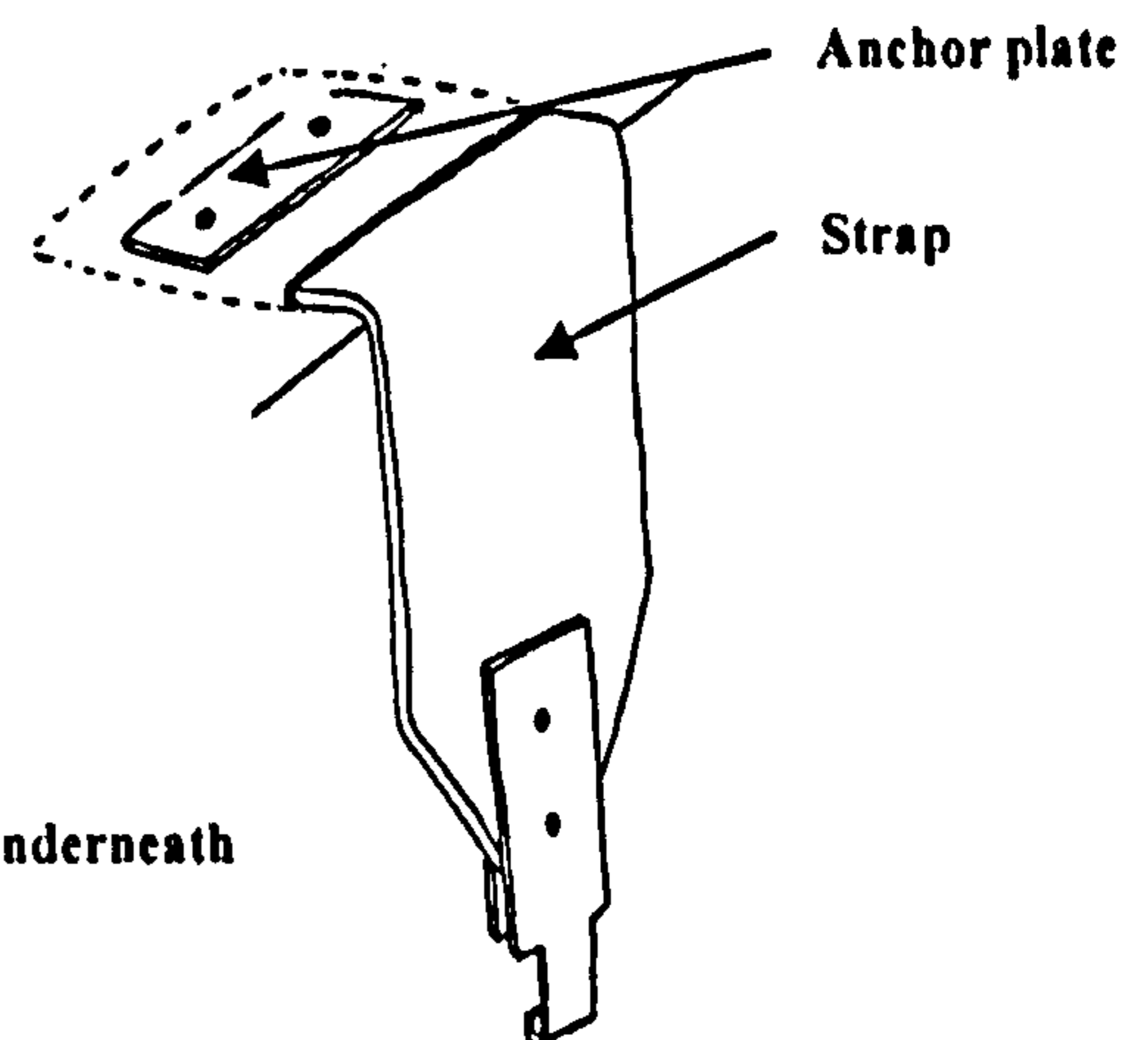

**Ends Form [Look-up Filed]:** indicates the form of the fastenings ends and its connection with the boards and pastedowns. 'Trimmed' refers to the ends of leather braids that might be left with the pointed ends of the leather straps untrimmed, or they could be trimmed close to the lacing of the leather straps.

- Trimmed underneath pastedowns,
- Trimmed pasted above pastedowns,

- (TuP),
- (TpaP)

Trimmed free above pastedowns,  
 Untrimmed free in the inside,  
 Untrimmed pasted in the inside above turn-ins,  
 Untrimmed under pastedowns,  
 Untrimmed pasted above pastedowns,  
 Untrimmed free above pastedowns,  
 Between cover and board,  
 Between cover and anchor plate,  
 Trimmed between pastedowns and pasted paper cuttings,  
 Untrimmed between pastedowns and pasted paper cutting,  
 Not Visible

(TfaP)  
 (Ufi)  
 (UpiaT)  
 (UuP)  
 (UpaP)  
 (UfaP)  
 (bCB)  
 (bCAP)  
 (TbPpPC)  
 (UbPpPC)  
 (N. V.)

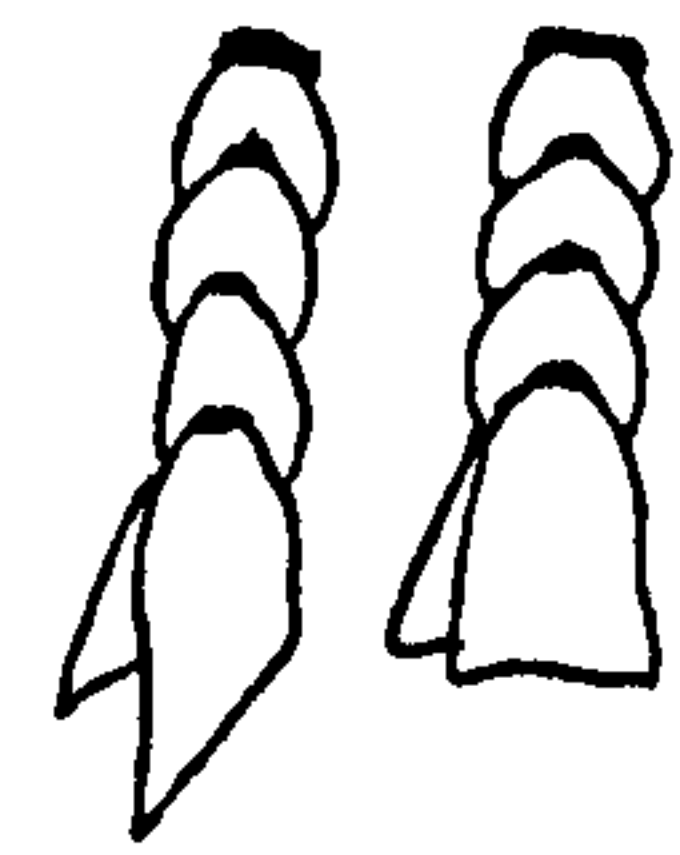

Trimmed fastening ends

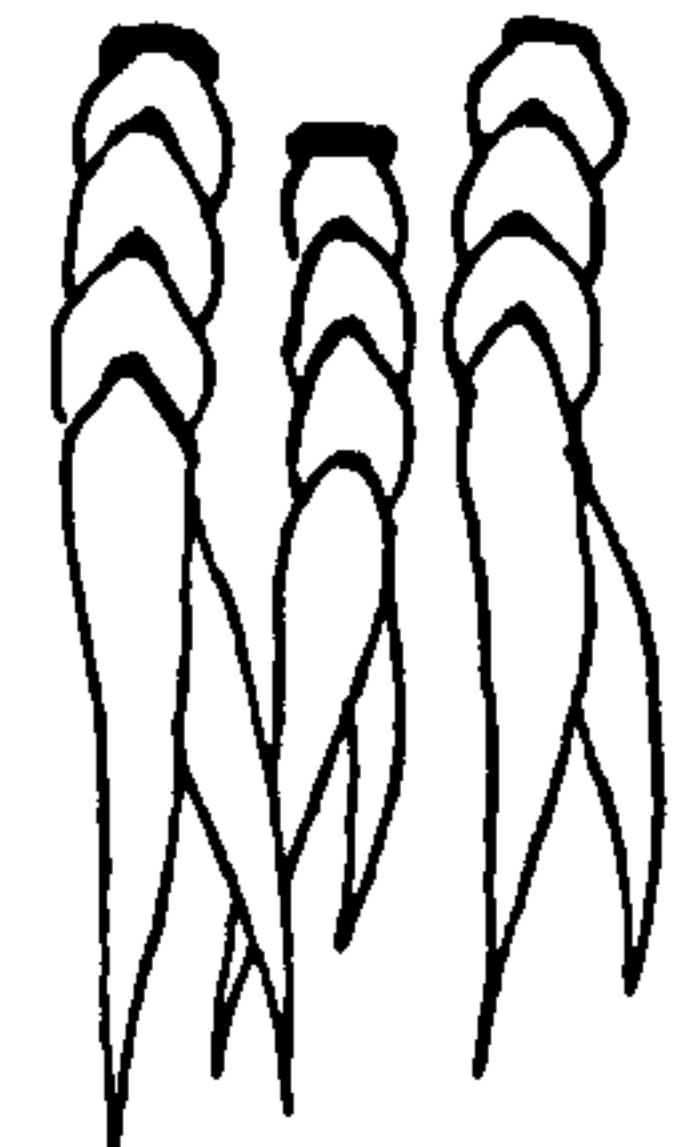

Untrimmed fastening ends

**Fastening's & Turn-ins Arrangement [Look-up Filed]:** Indicates the disposition of the cover's turn-ins with respect to the ends of the fastenings:

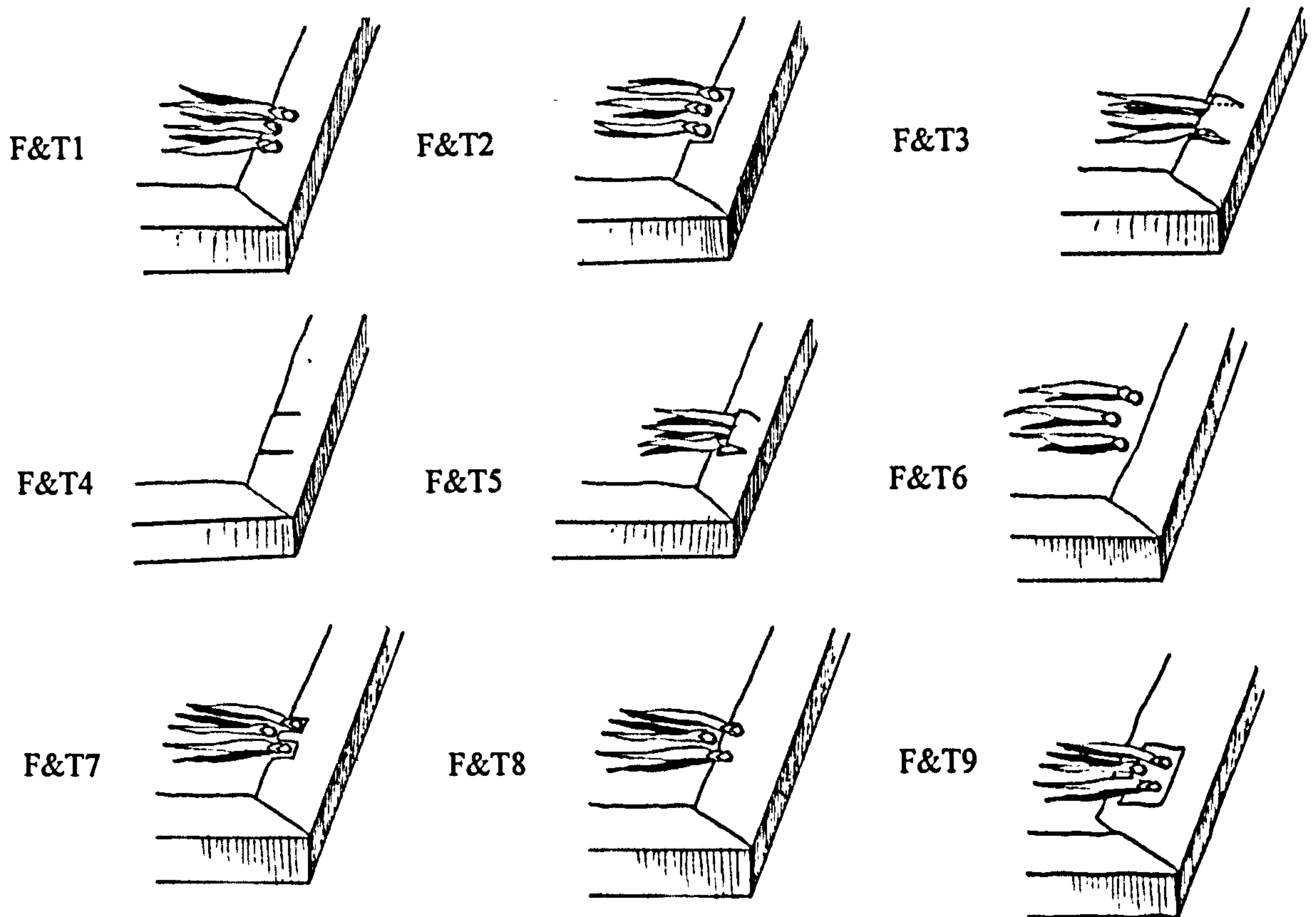

**Notes on fastenings [Free-text].** Collects any information on the fastenings which can not be included in the fields aforementioned.

**GENERAL NOTES** includes the following fields:

**General Notes [Free Text]:** collects any information, impression or anything else that could not be recorded in any other field of the database. It also contains notations, remarks and points out any possible relation of the present book with others.

**Text-block Preservation [Free-Text]:** indicates the state of preservation of the text-block of the surveyed volume.

**Binding Preservation [Free-Text]:** indicates the state of preservation of the binding of the surveyed volume.

**Photographs [Free-Text]:** indicates the kind of images taken (photographs, slides or digital images).

**Slides:** indicates the serial number of slides taken from the book.

## **Appendix 5**

# MUF

## a) DAISY-LIKE FLOWER



MuF/a1

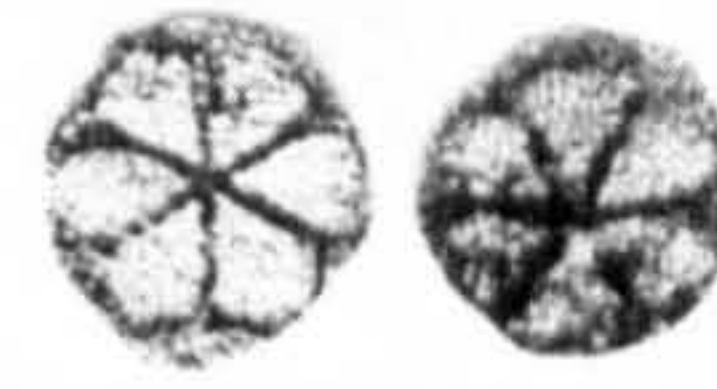

MuF/a41



MuF/a4



MuF/a42



MuF/a43

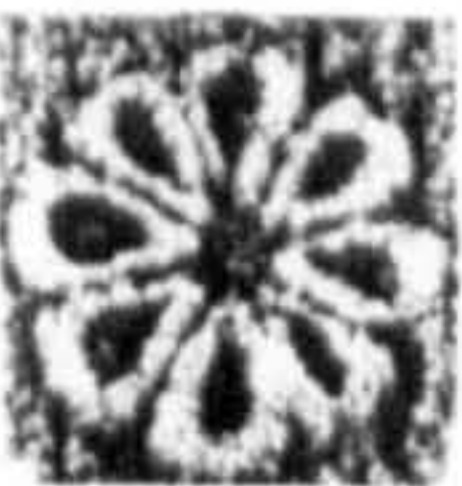

MuF/a29

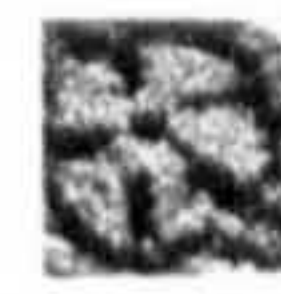

MuF/a51



MuF/a31



MuF/a53



MuF/a48



MuF/a60



MuF/a72

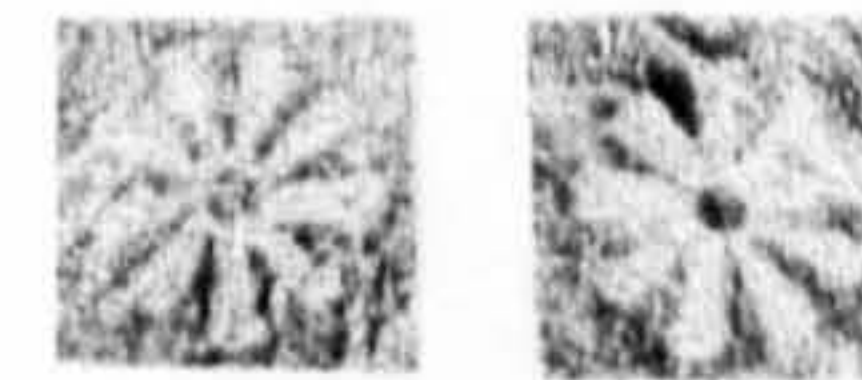

MuF/a61



MuF/a66

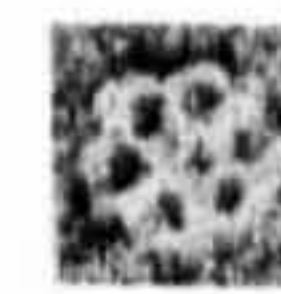

MuF/a74



MuF/a7



MuF/a77



MuF/a27



MuF/a11



MuF/a6



MuF/a5

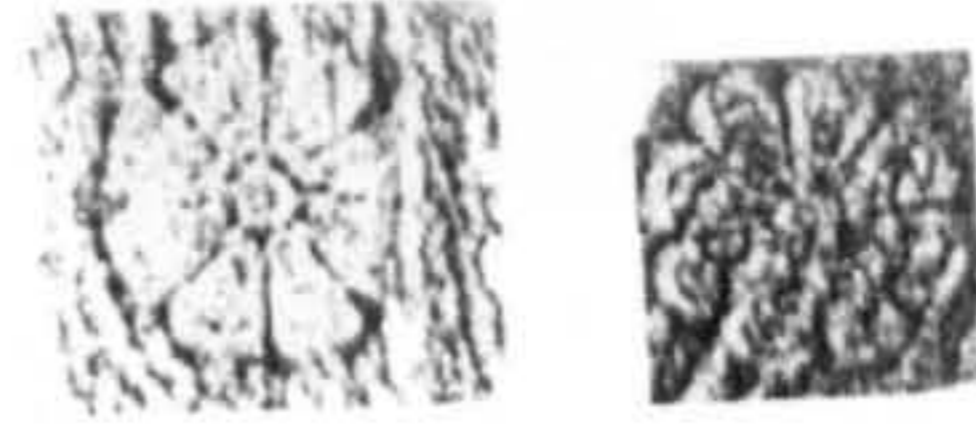

MuF/a56



MuF/a15

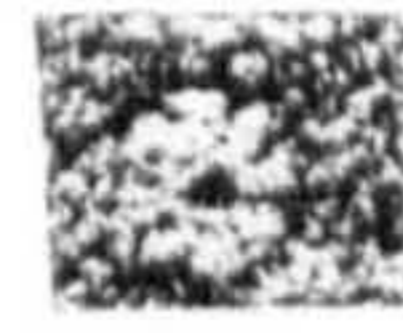

MuF/a58



MuF/a28



MuF/a62

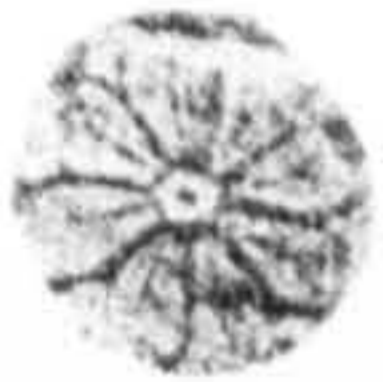

MuF/a20



MuF/a73



MuF/a22

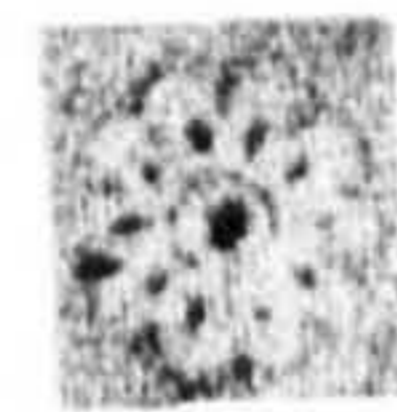

MuF/a76



MuF/a12



MuF/a2

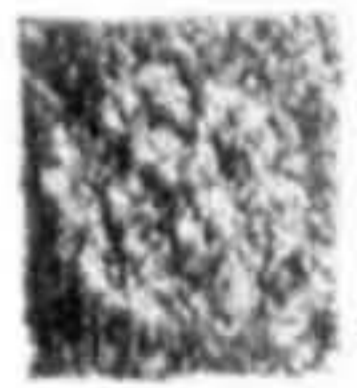

MuF/a23



MuF/a3



MuF/a24



MuF/a8

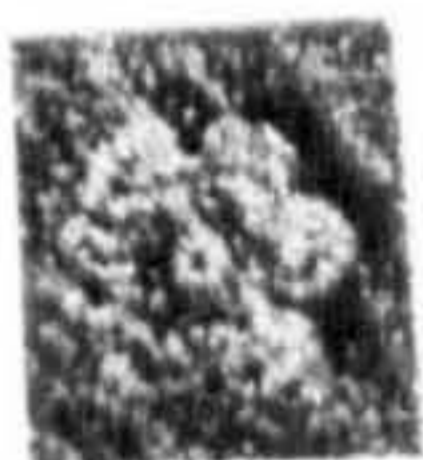

MuF/a26

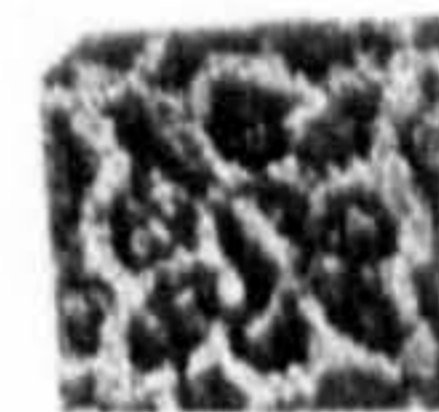

MuF/a9

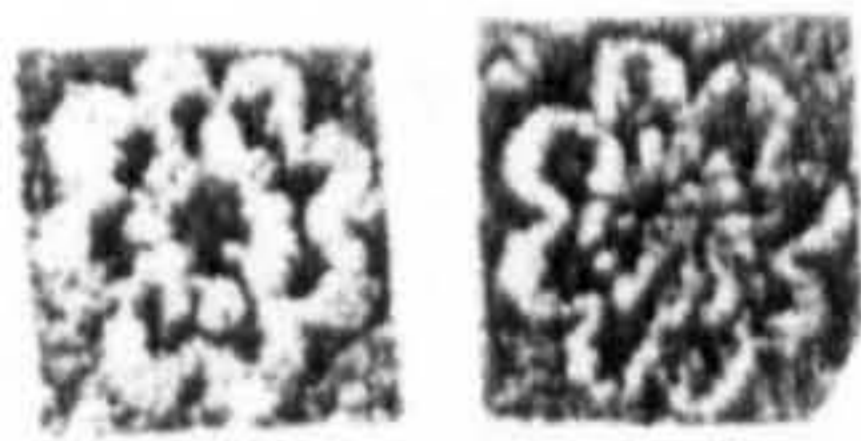

MuF/a30



MuF/a47



MuF/a35



MuF/a50



MuF/a36



MuF/a55





MuF/a37

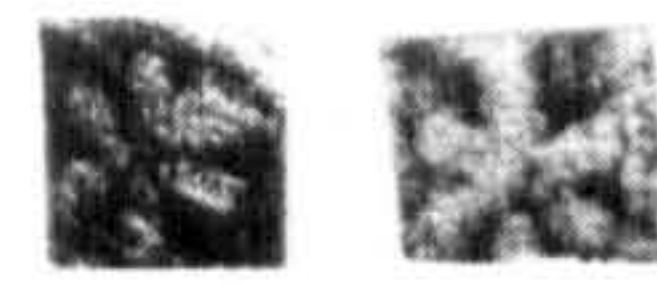

MuF/a49



MuF/a40

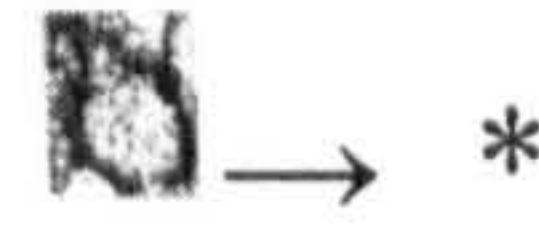

MuF/a59

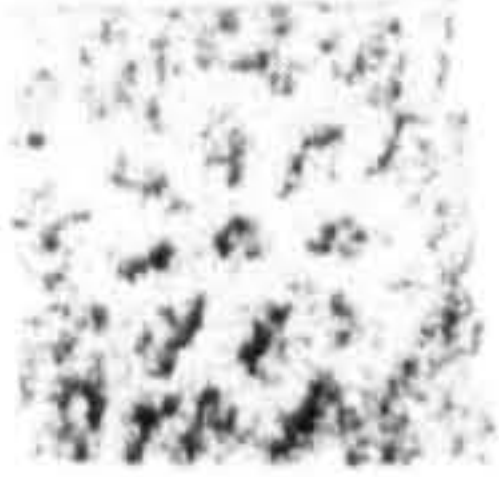

MuF/a45

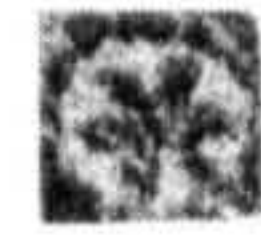

MuF/a63



MuF/a52

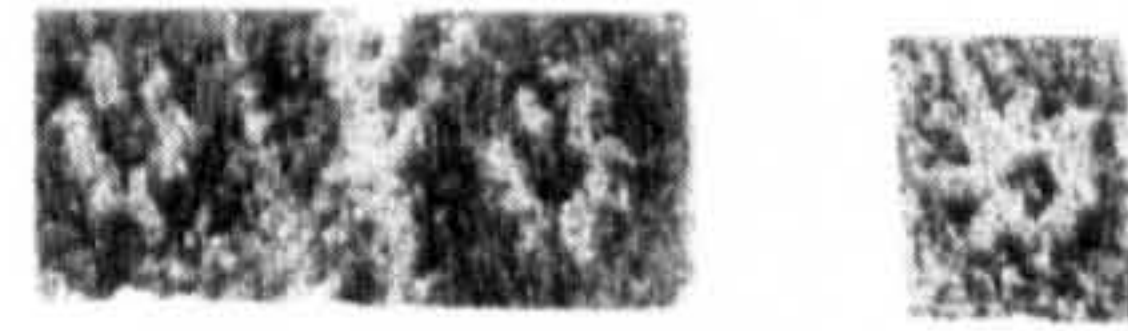

MuF/a64



MuF/a70



MuF/a65



MuF/a34



MuF/a67



MuF/a75



MuF/a68

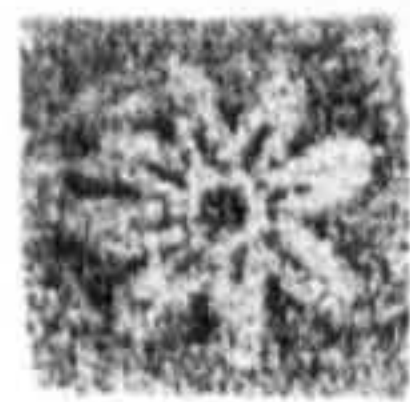

MuF/a10



MuF/a69

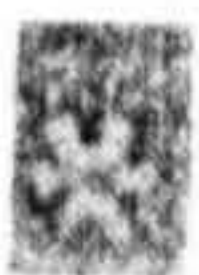

MuF/a16



MuF/a13

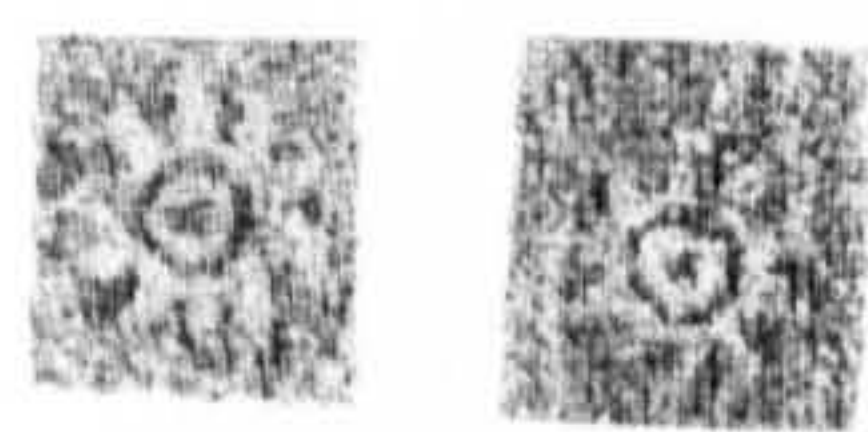

MuF/a18

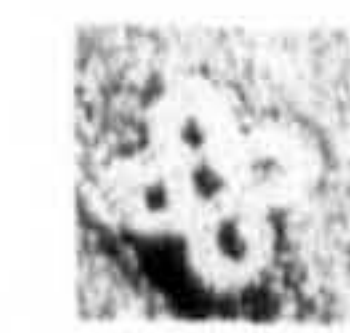

MuF/a14

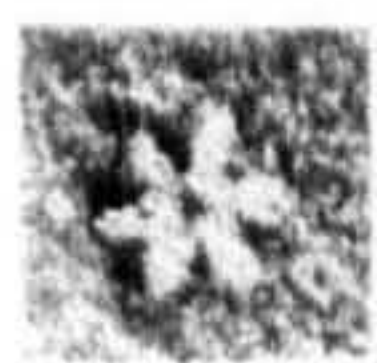

MuF/a25

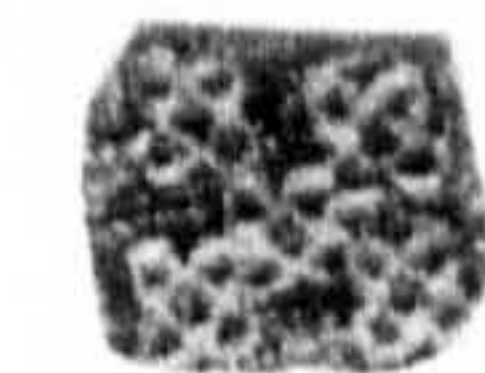

MuF/a38



MuF/a39



MuF/a17



MuF/a46



MuF/a21



MuF/a32



MuF/a44



MuF/a57

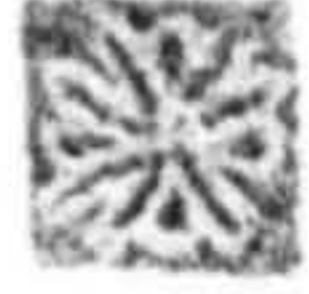

MuF/a19



MuF/a33



MuF/a54



MuF/a71



MuF/a78

b) FLOWER STEM

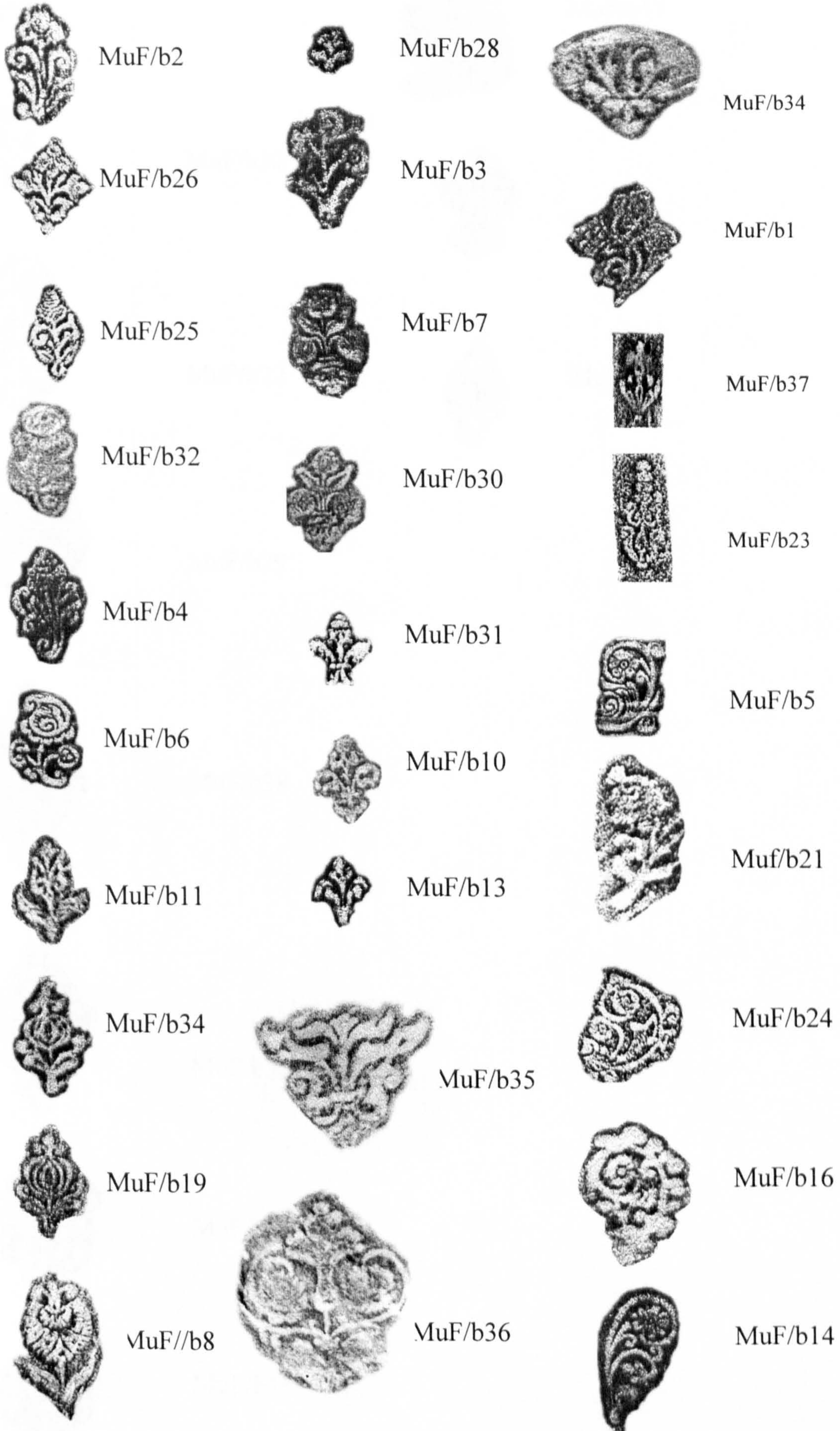



MuF/b30



MuF/b18



MuF/b20



MuF/b17



MuF/b22



MuF/b39



MuF/b29



MuF/b38



MuF/b33



MuF/b12



MuF/b15

c) FLEUR-DE-LIS



MuF/c1



MuF/c40



MuF/c2



MuF/c46



MuF/c5



MuF/c47



MuF/c17



MuF/c3



MuF/c28



MuF/c26



MuF/c37



MuF/c27



MuF/c38



MuF/c30



MuF/c39



MuF/c36



MuF/c13



MuF/c48 (MuF/f9)



MuF/c49

c) FLEUR-DE-LIS



MuF/c1



MuF/c40

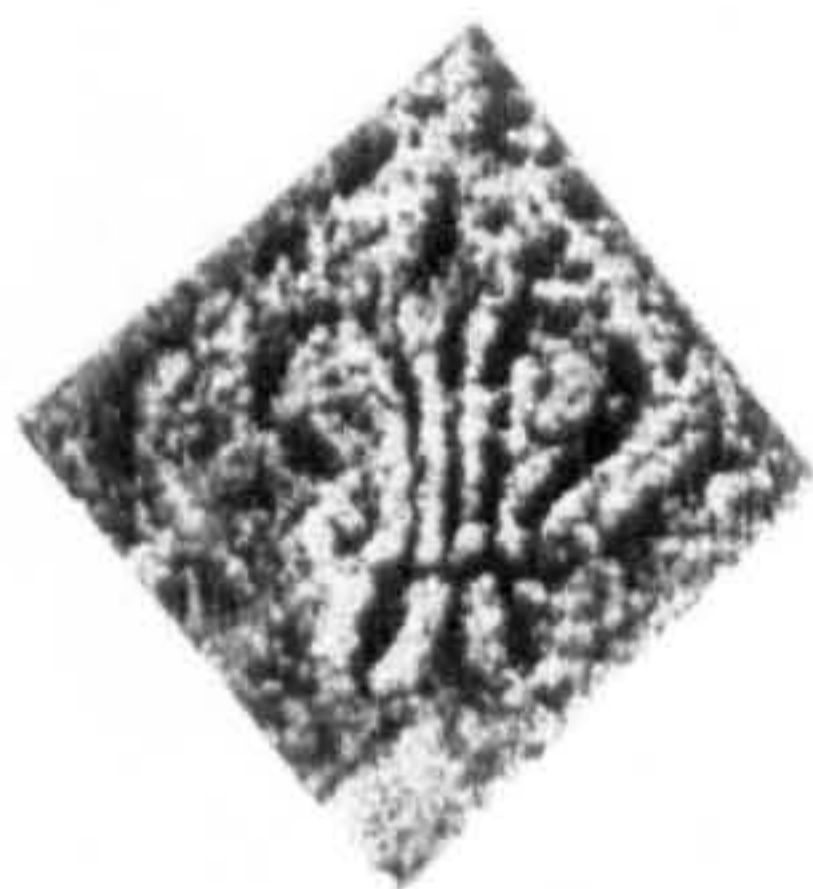

MuF/c2



MuF/c46



MuF/c5



MuF/c47



MuF/c17



MuF/c3



MuF/c28



MuF/c26



MuF/c37



MuF/c27



MuF/c38



MuF/c30



MuF/c39



MuF/c36



MuF/c13



MuF/c48 (MuF/t9)

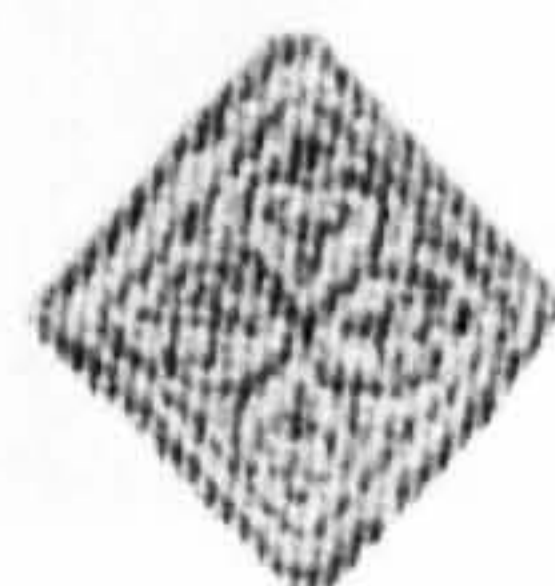

MuF/c49



MuF/c4



MuF/c22



MuF/c18



MuF/c24



MuF/c23



MuF/c41



MuF/c6



MuF/c44



MuF/c10



MuF/c34



MuF/c11



MuF/c15



MuF/c12

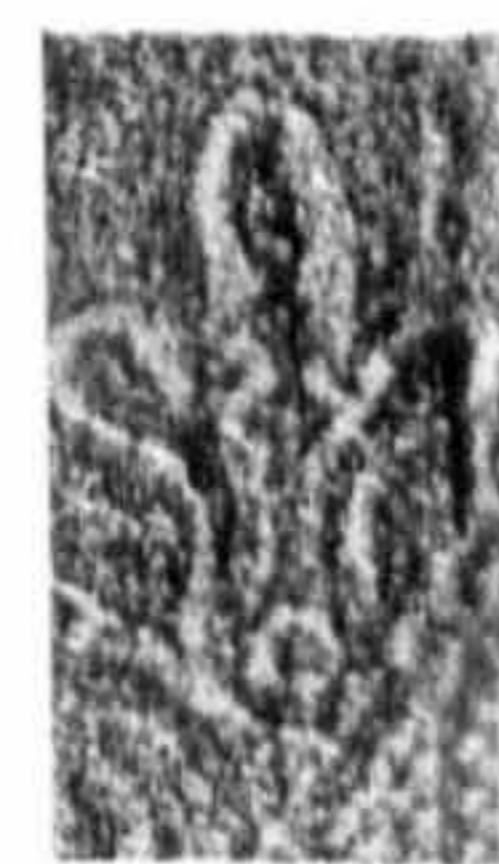

MuF/c19



MuF/c16



MuF/c20



MuF/c35



MuF/c21



MuF/c7

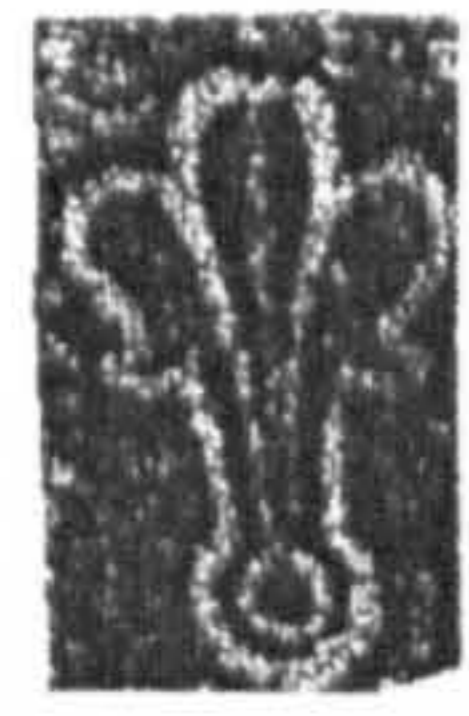

MuF/c8



MuF/c9



MuF/c50



MuF/c31



MuF/c32



MuF/c25



MuF/c43



MuF/c14



MuF/c29



MuF/c33



MuF/c42



MuF/c45



d) REPEATING MOTIFS

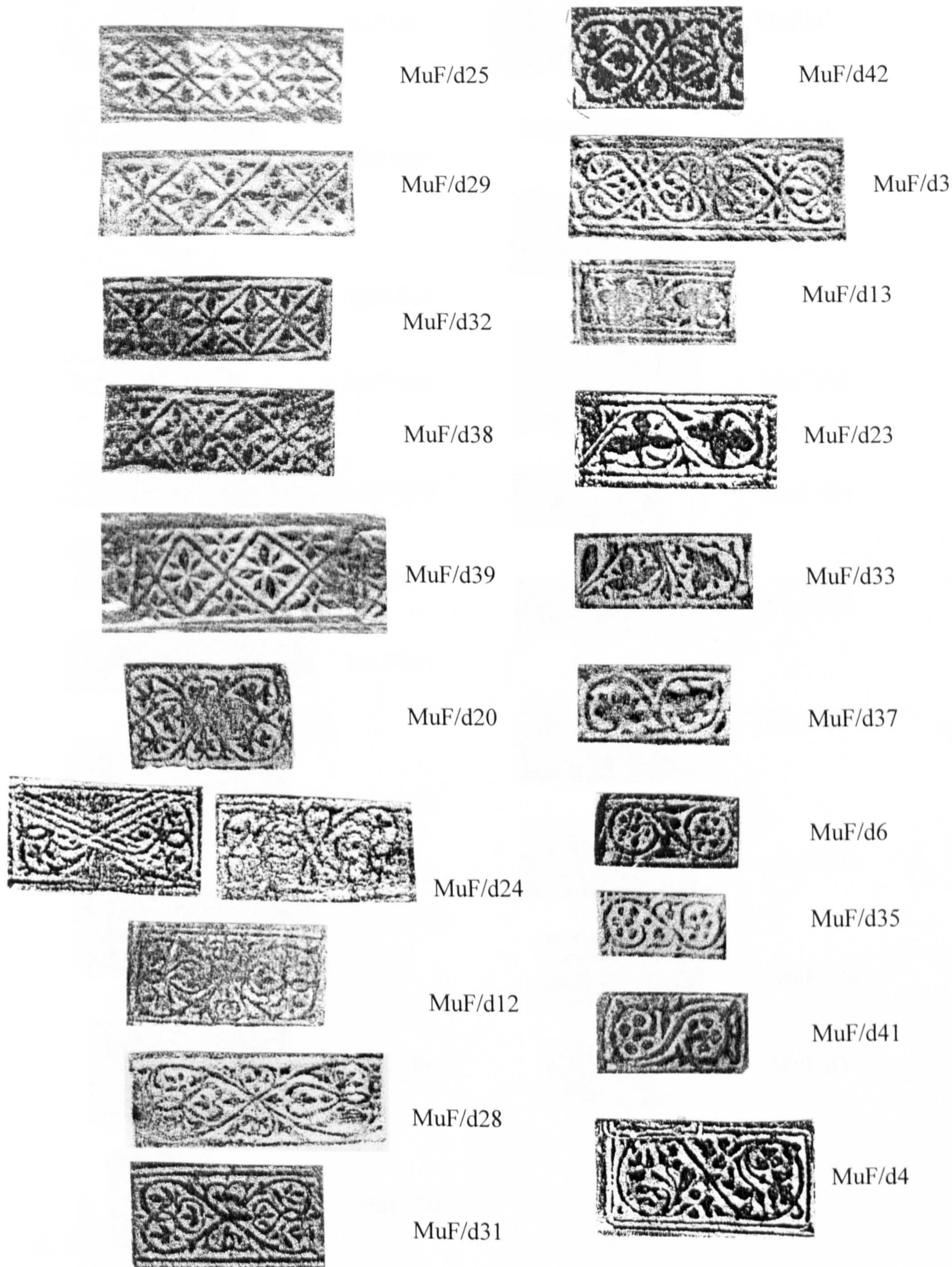



MuF/d8



MuF/d2



MuF/d26



MuF/d5



MuF/d10



MuF/d7

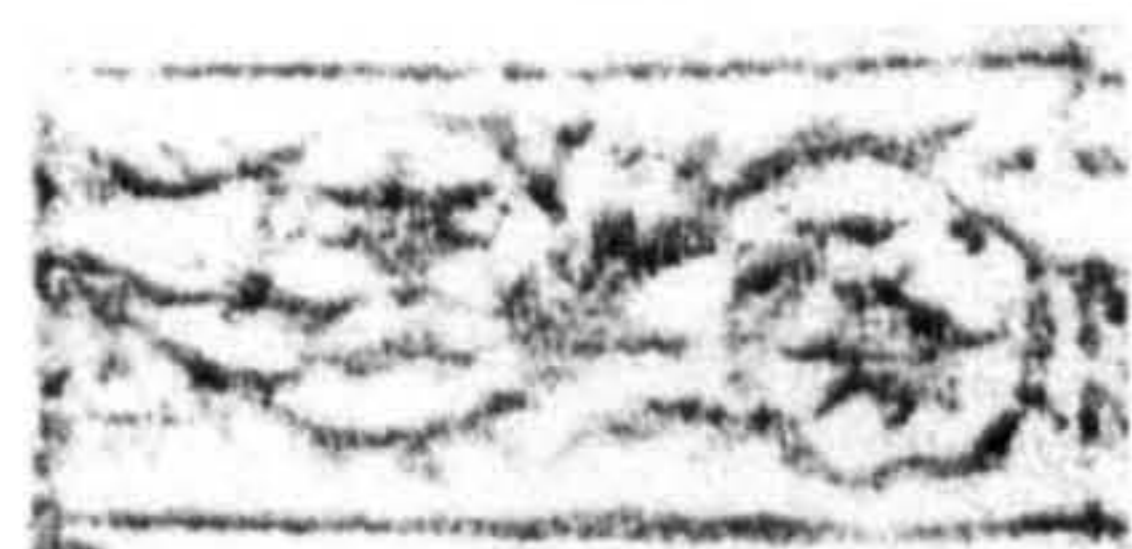

MuF/d40



MuF/d11



MuF/d15



MuF/d14



MuF/d16



MuF/d18



MuF/d17



MuF/d27



MuF/d19



MuF/d30



MuF/d22



MuF/d34



MuF/d9

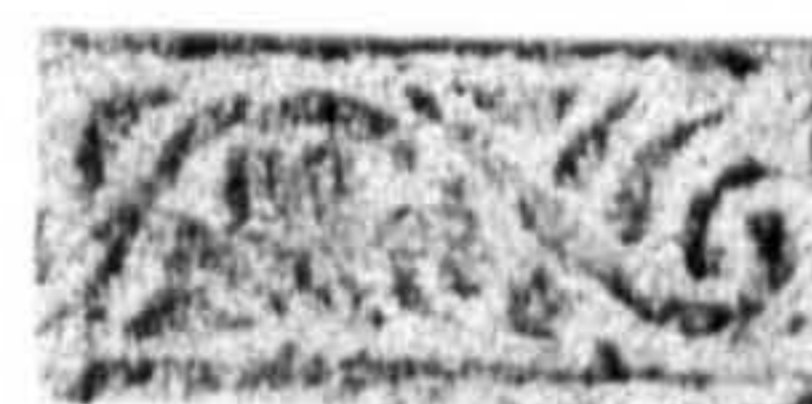

MuF/d36



MuF/d21



MuF/d1

e) OTHER



MuF/e1



MuF/e12



MuF/e2



MuF/e13



MuF/e3



MuF/e8



MuF/e4



MuF/e15



MuF/e5



MuF/e10



MuF/e6



MuF/e9



MuF/e7



MuF/e18



MuF/e11



MuF/e16



MuF/e36



MuF/e26



MuF/e17



MuF/e27



MuF/e41



MuF/e21



MuF/e30



MuF/e24



MuF/e35



MuF/e25



MuF/e42

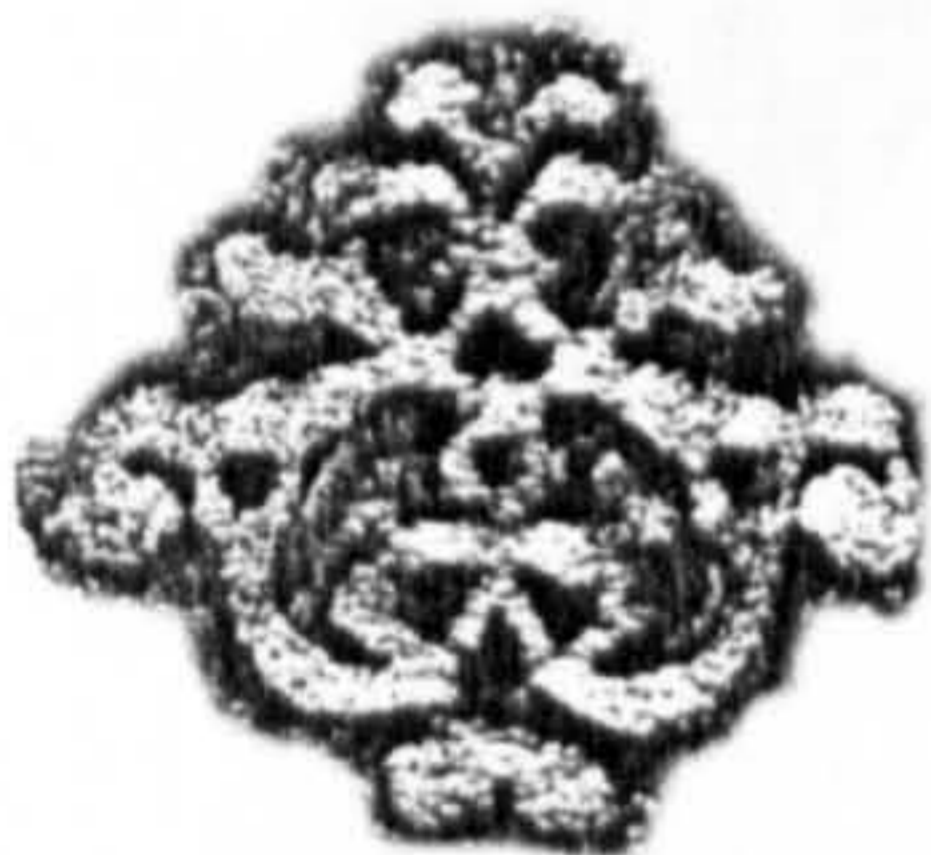

MuF/e28



MuF/e38



MuF/e32



MuF/e40



MuF/e33

# MuA

## a) EAGLE / BIRD

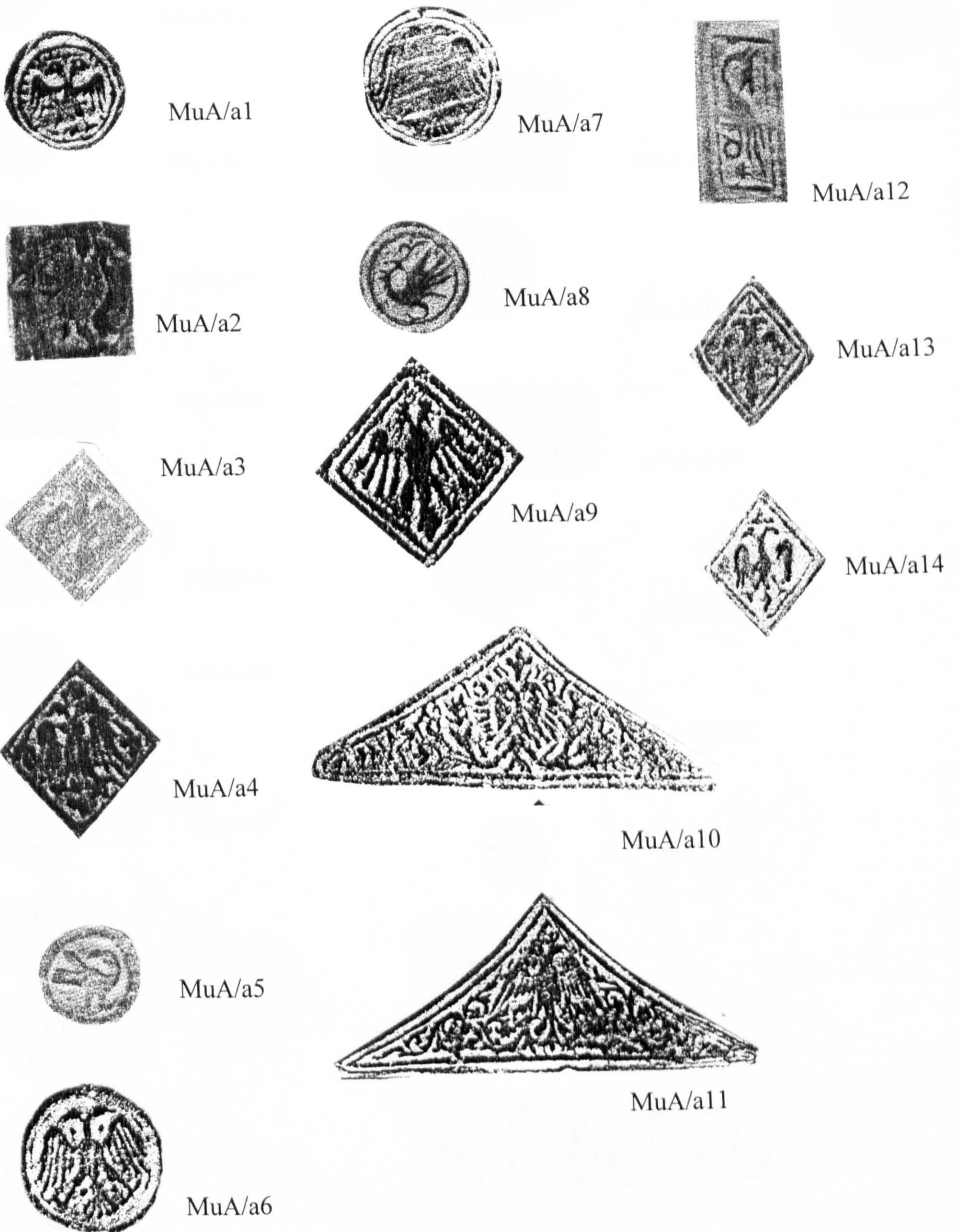

b) QUADRUPED



c) DRAGON



MuA/c1



MuA/c2



MuA/c3



MuA/c4

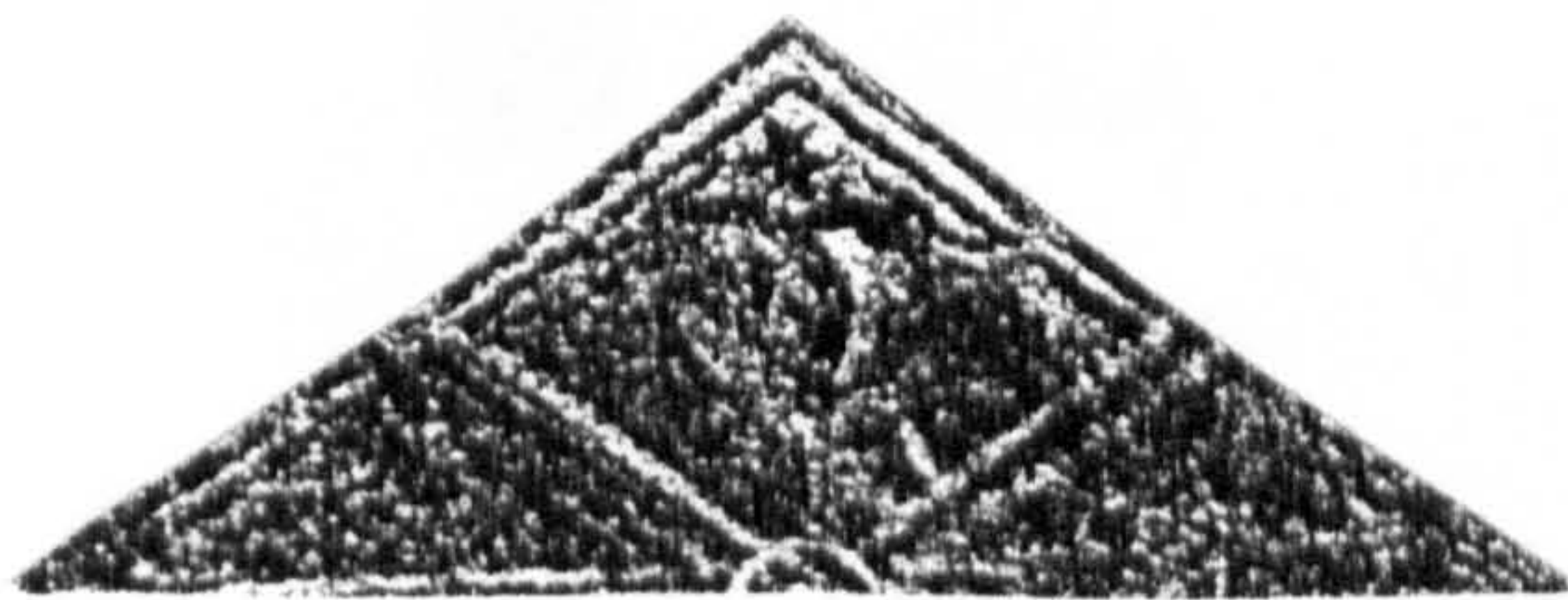

MuA/c5



MuA/c6

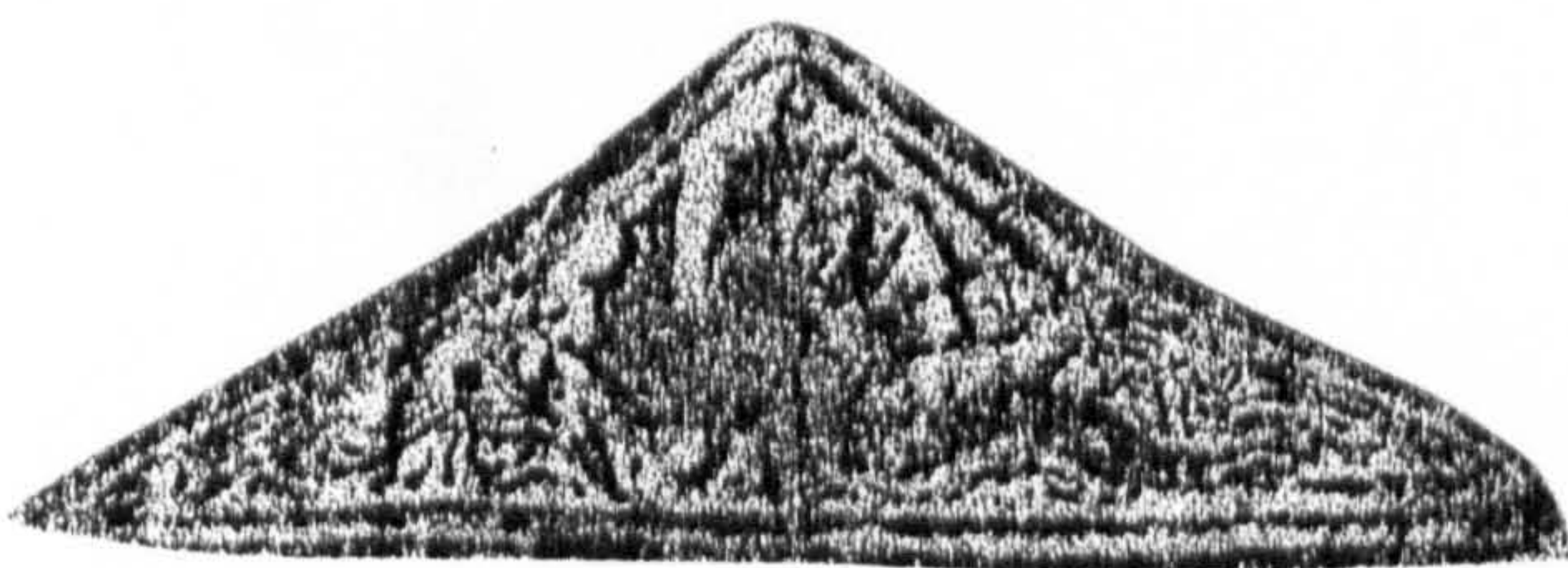

MuA/c11



MuA/c7



MuA/c8



MuA/c9



MuA/c10

# MuG

## a) RING



MuG/a1

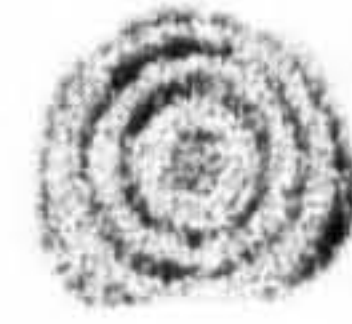

MuG/a17



MuG/a2



MuG/a18



MuG/a3



MuG/a19



MuG/a4



MuG/a20



MuG/a5



MuG/a21



MuG/a6



MuG/a22



MuG/a7



MuG/a8



MuG/a9



MuG/a10



MuG/a11



MuG/a12



MuG/a13



MuG/a14



MuG/a15



MuG/a16



b) INTERLACED MOTIFS



MuG/b1



MuG/b11



MuG/b2



MuG/b12



MuG/b3



MuG/b4



MuG/b5

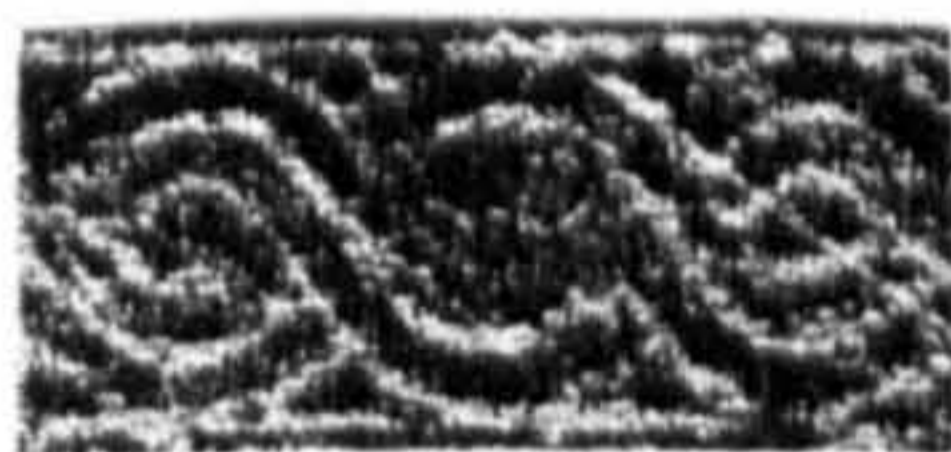

MuG/b6



MuG/b7



MuG/b8



MuG/b9



MuG/b10

c) OTHER

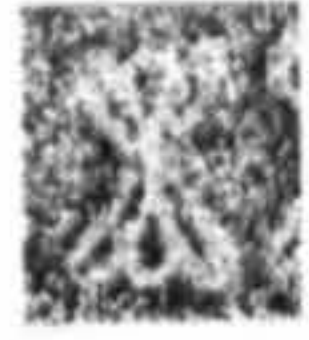

MuG/c1



MuG/c2



MuG/c3



MuG/c4



MuG/c5



MuG/c6



MuG/c7



MuG/c8



MuG/c9

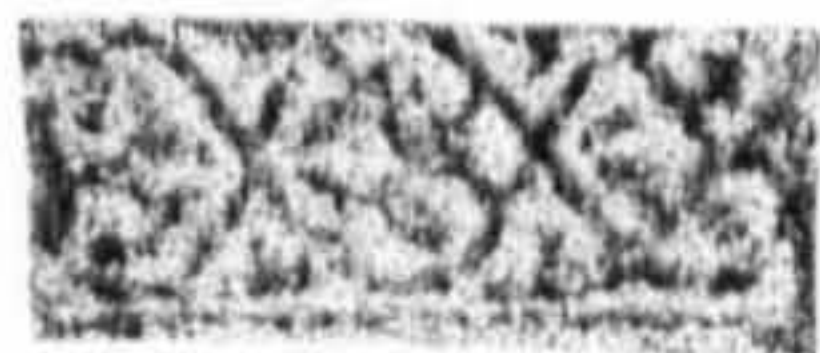

MuG/c10



MuG/c11



MuG/c12

# MuV



MuV1



MuV2



MuV3



MuV4



MuV5



MuV6



MuV7



MuV8



MuV9



MuV10



MuV11



MuV12



MuV13



MuV14



MuV15



MuV16



MuV17



MuV18

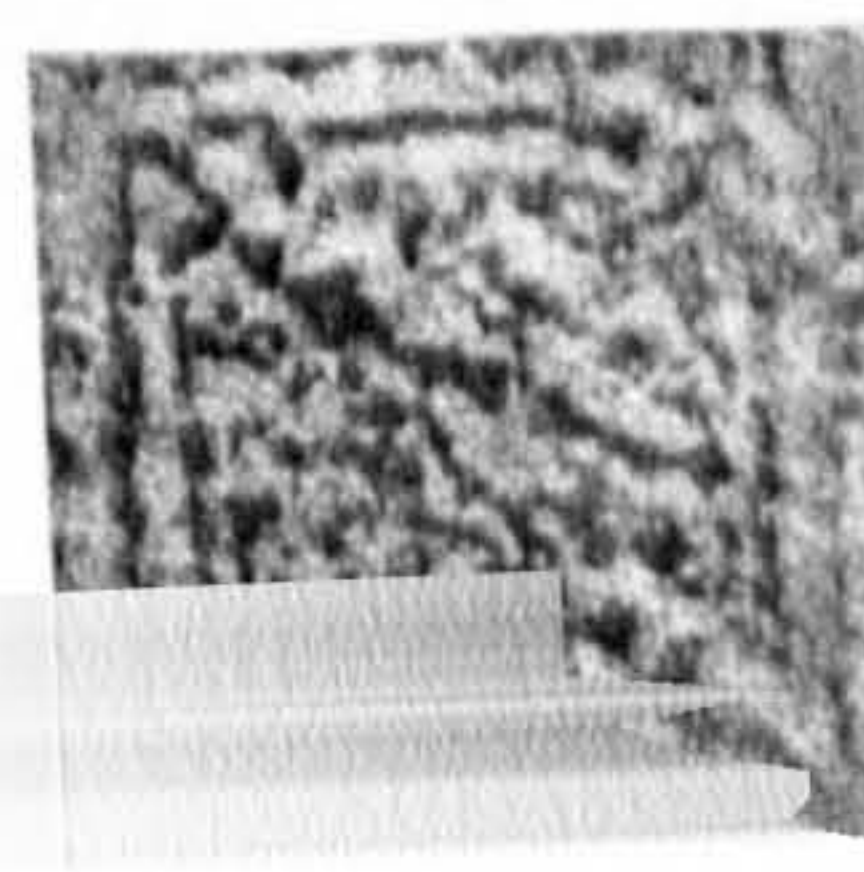

MuV19

MuV20



# ROF



RoF1



RoF2



RoF3



RoF4

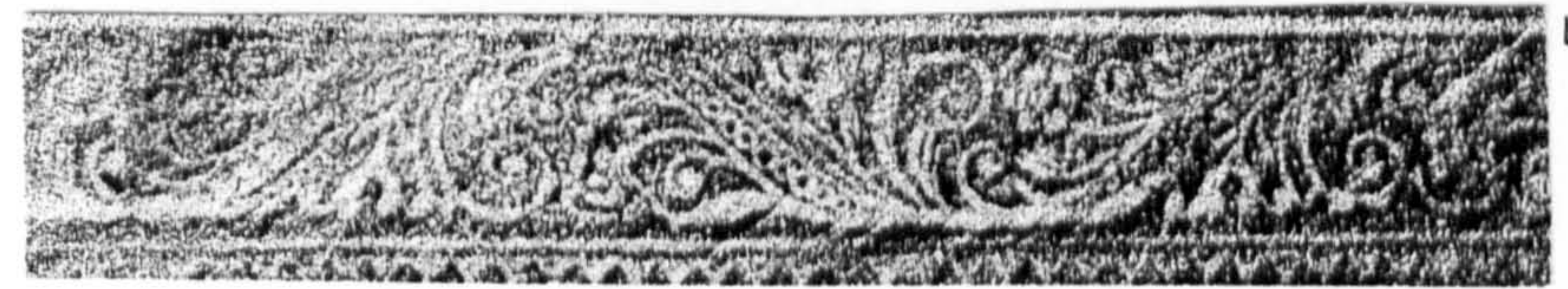

RoF5

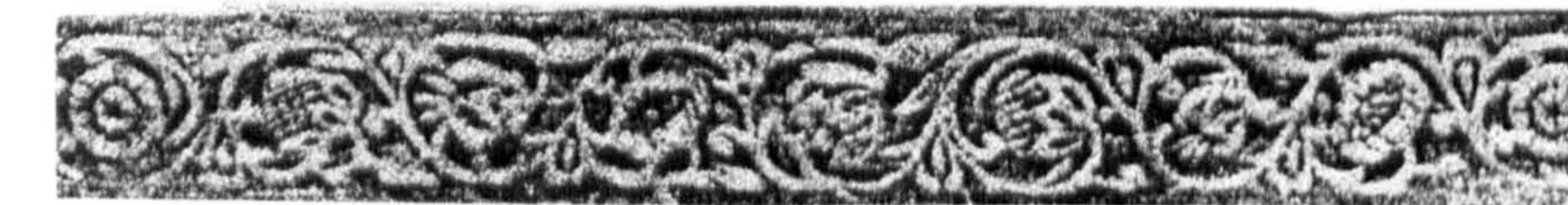

RoF6



RoF7



RoF8



RoF9



RoF10



RoF11



RoF12



RoF13



RoF14



RoF15



RoF16



RoF17



RoF18



RoF19



RoF20

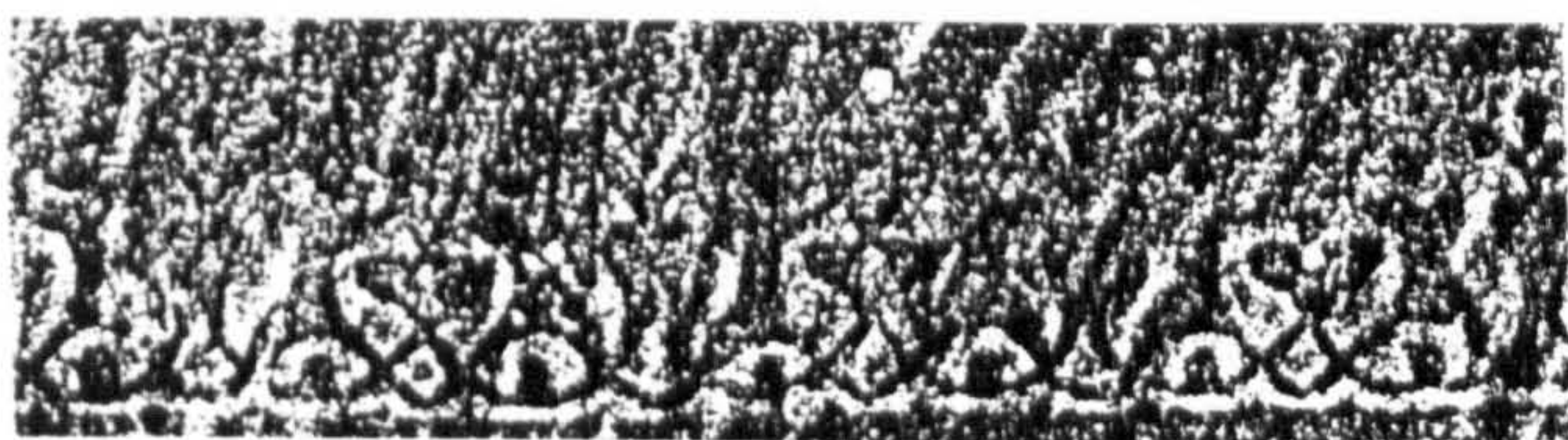

RoF21



RoF22



RoF23



RoF24



RoF25



RoF26

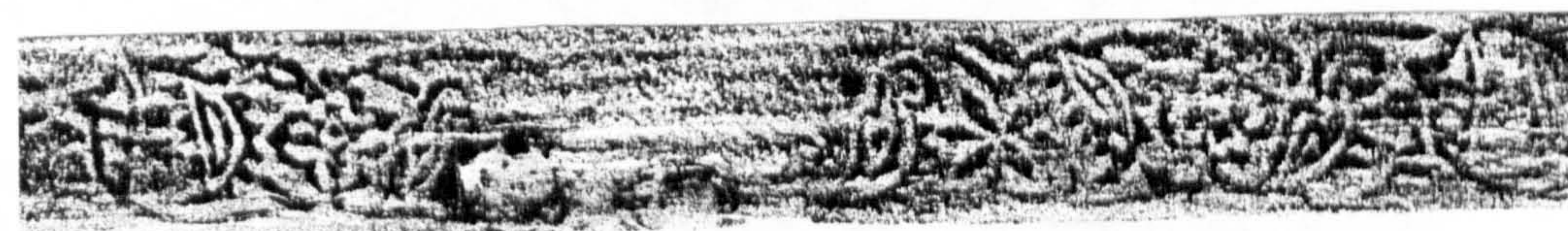

RoF27



RoF28



RoF29



RoF30



RoF31



RoF32

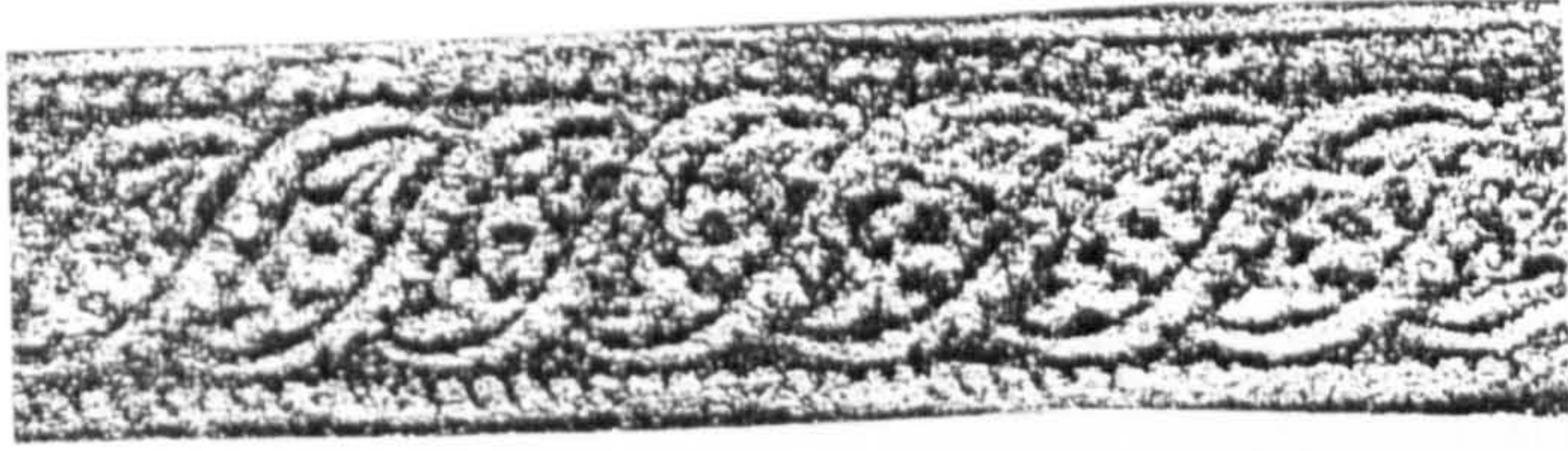

RoF33



RoF34



RoF35

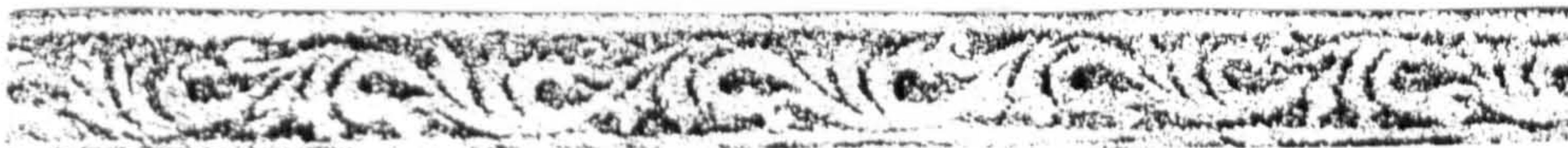

RoF36



RoF37



RoF38

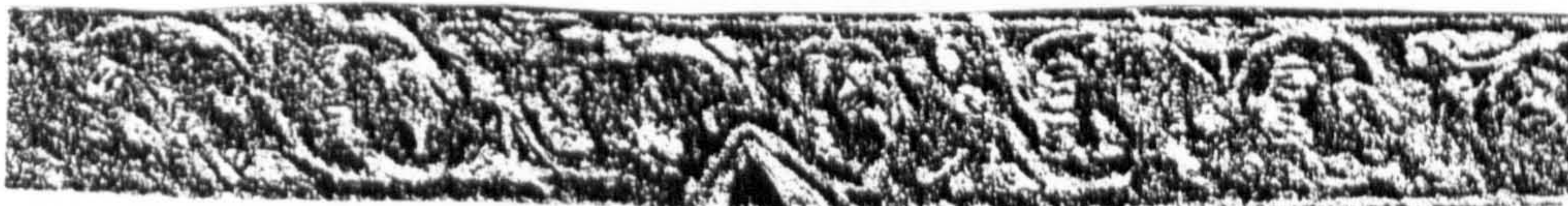

RoF39



RoF40



RoF41



RoF42



RoF43

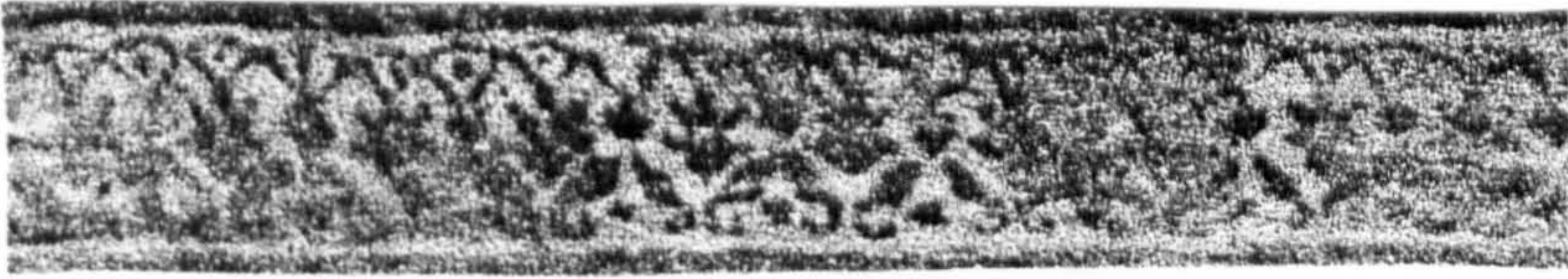

RoF44



RoF45



RoF46



RoF47

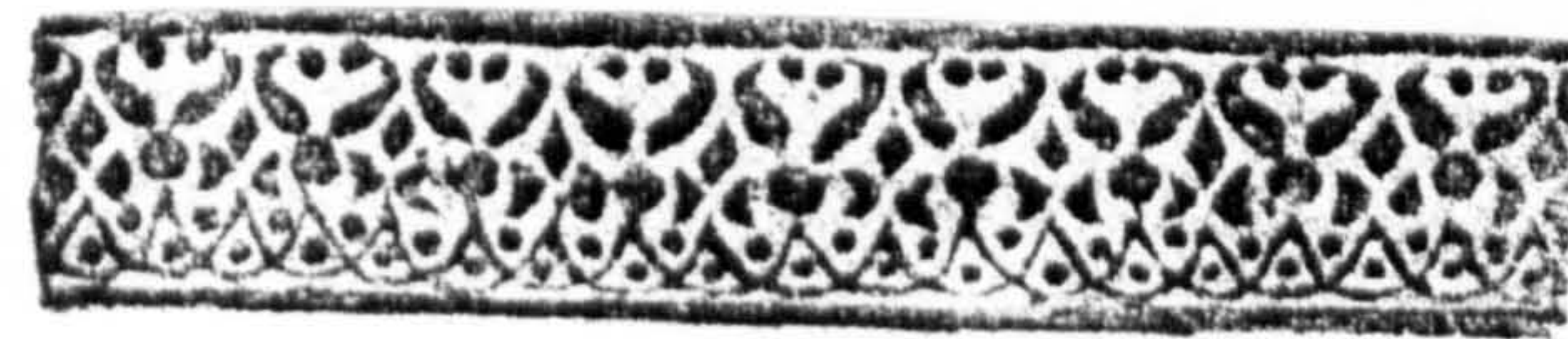

RoF48



RoF49

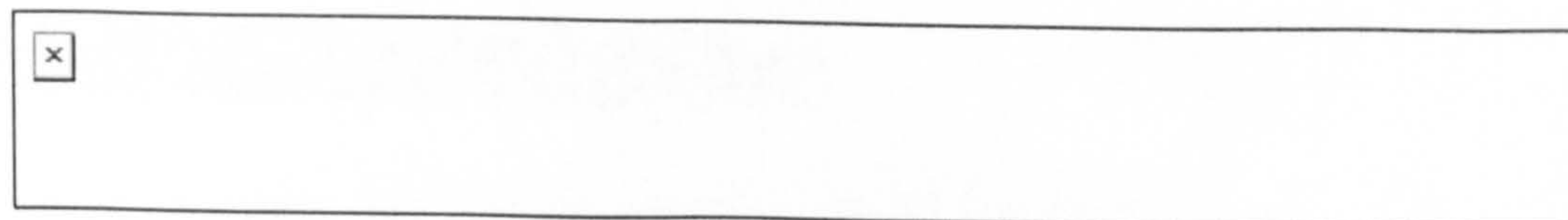

RoF50

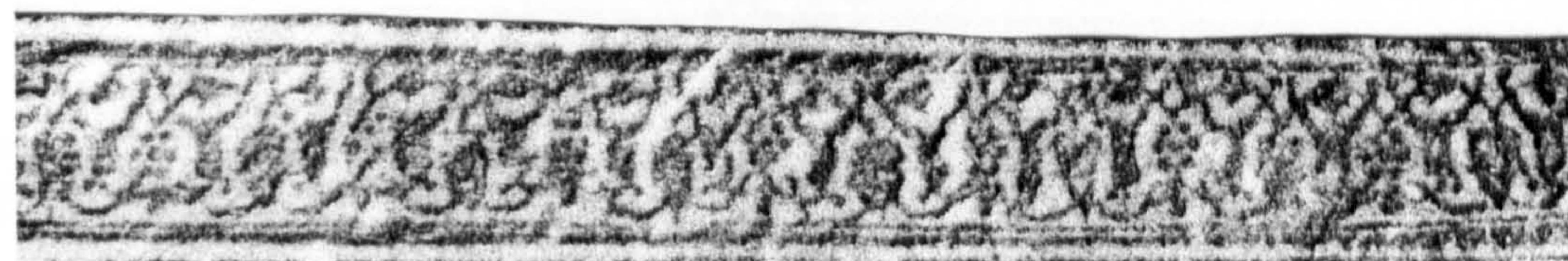

RoF51



# ROG



RoG1



RoG2



RoG3



RpG4



RoG5



RoG6



RoG7



RoG8

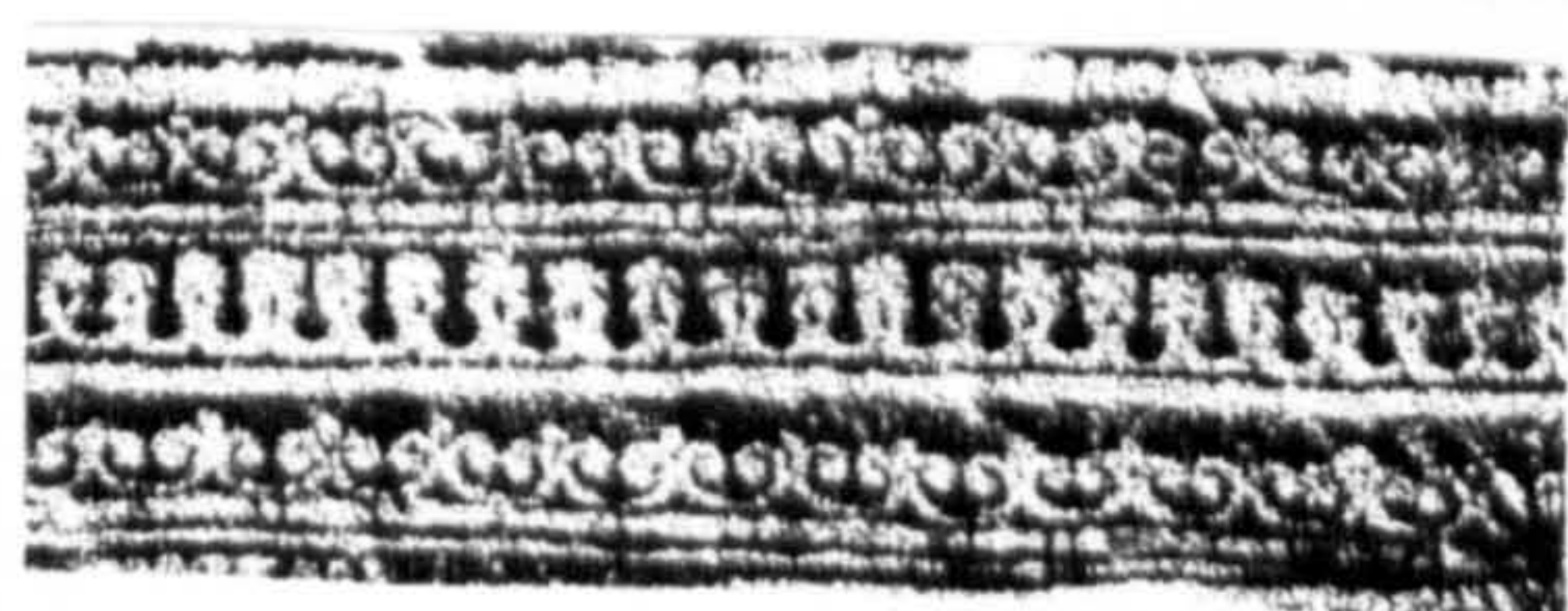

RoG9



RoG10



RoG12



RoG13



RoG14



RoG15



RoG16



RoG17



RoG18



RoG19



RoG20

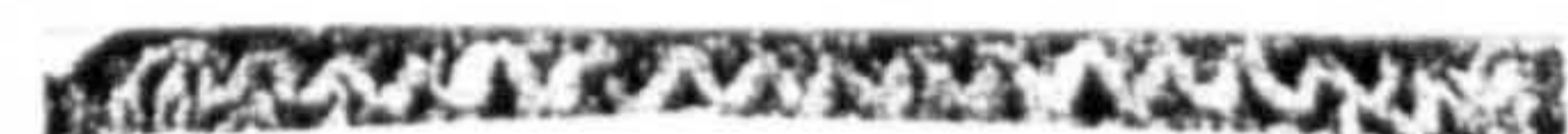

RoG21

CEF



CeF5

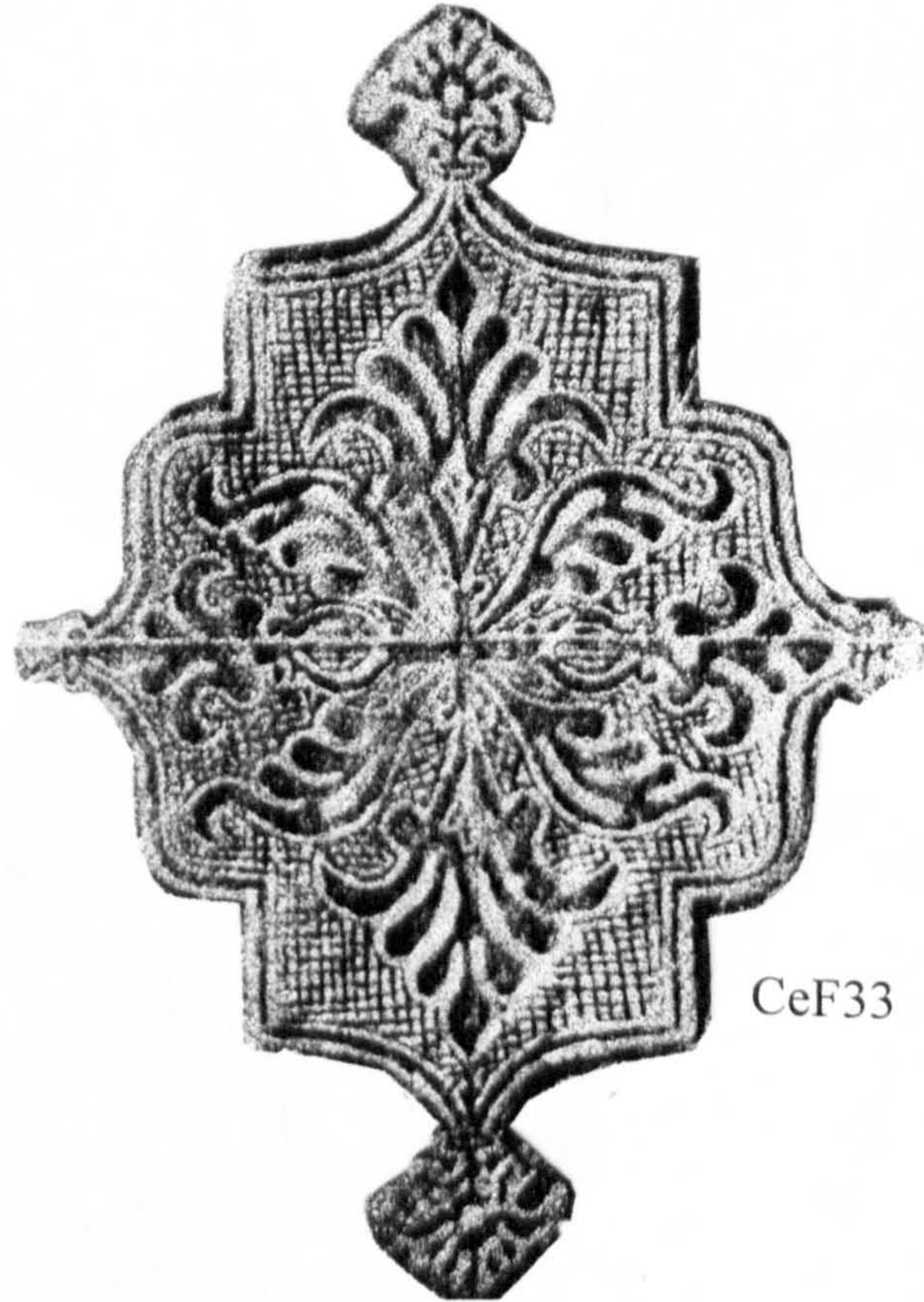

CeF33



CeF14

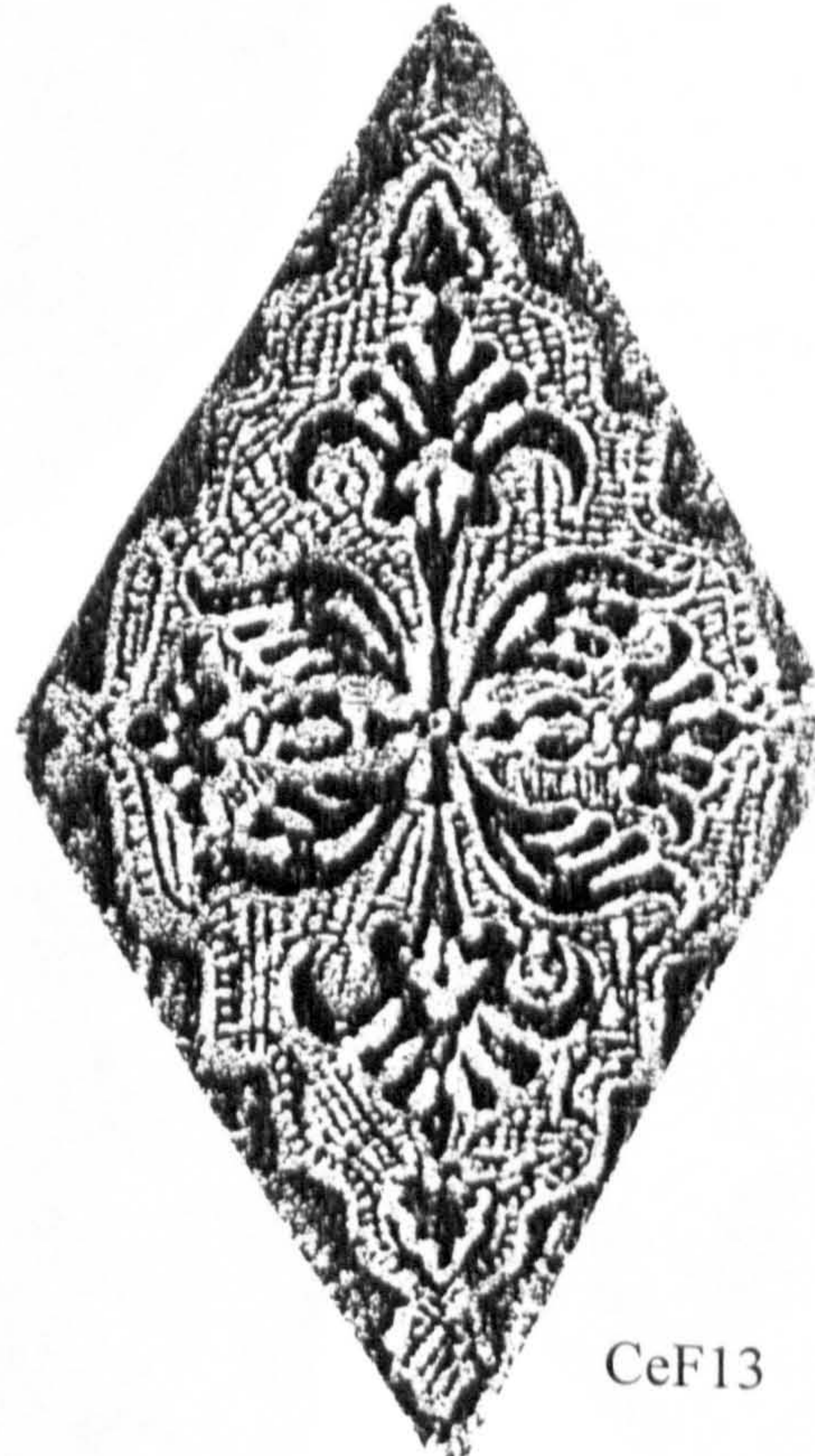

CeF13

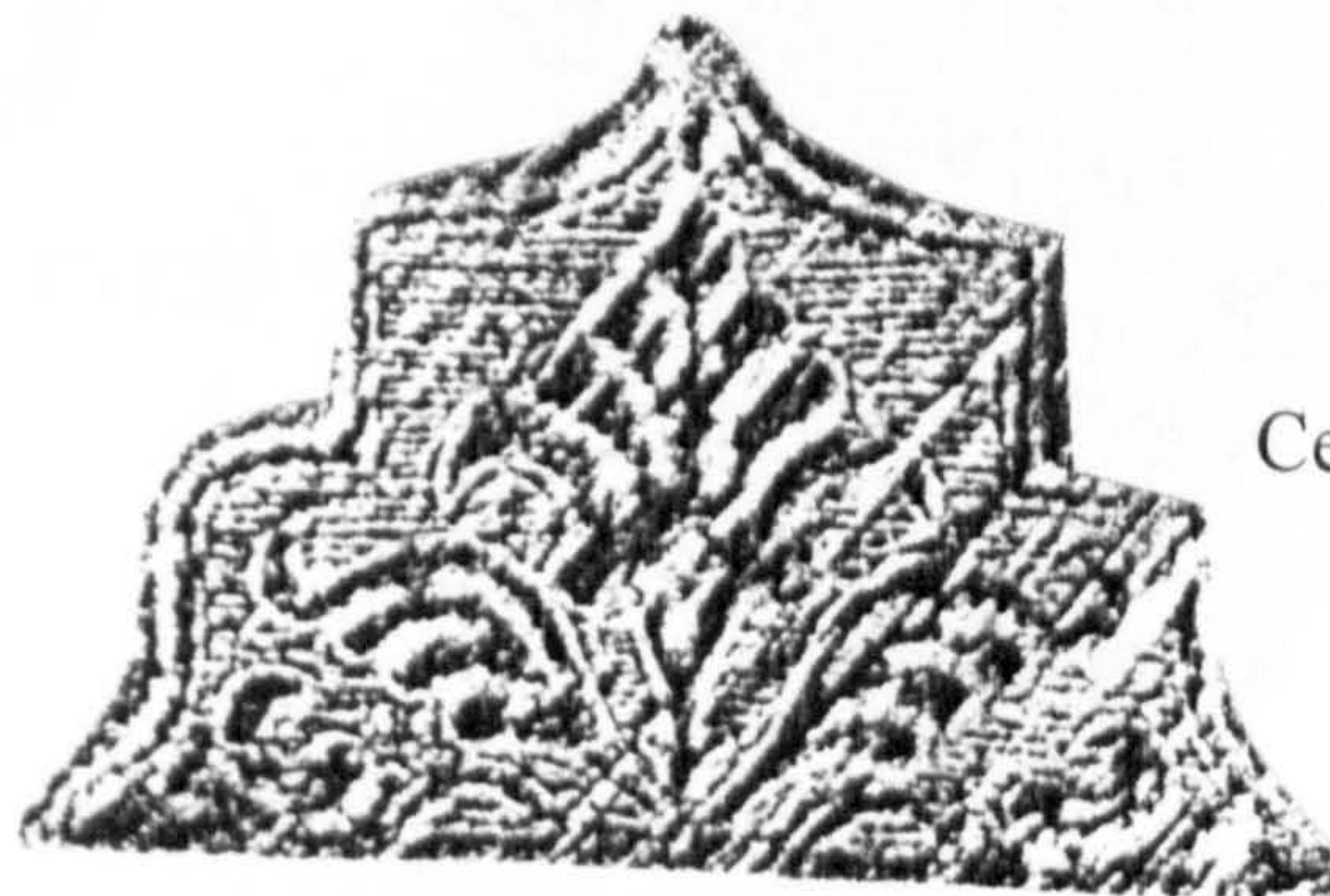

CeF15

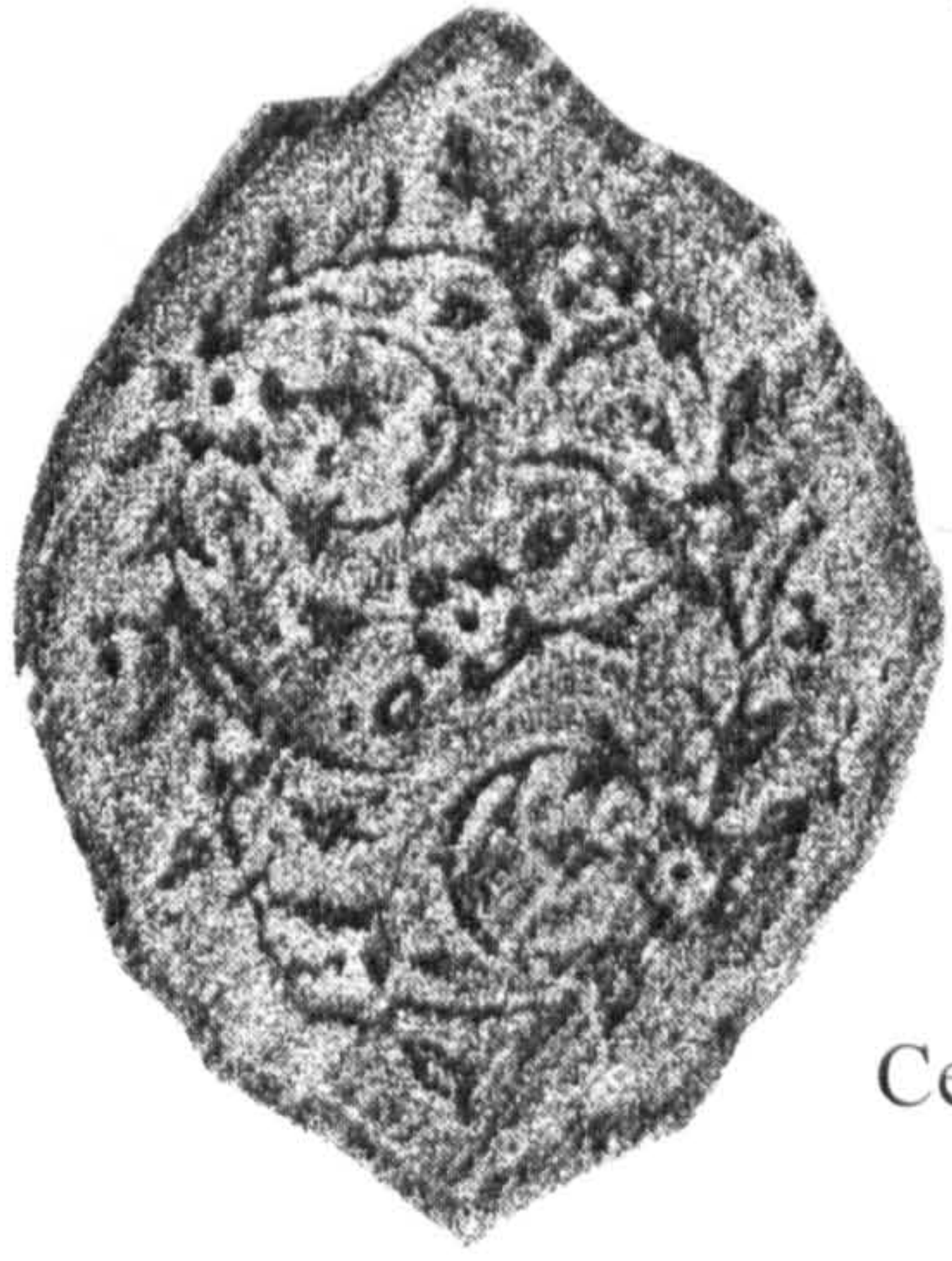

CeF3



CeF30



CeF31

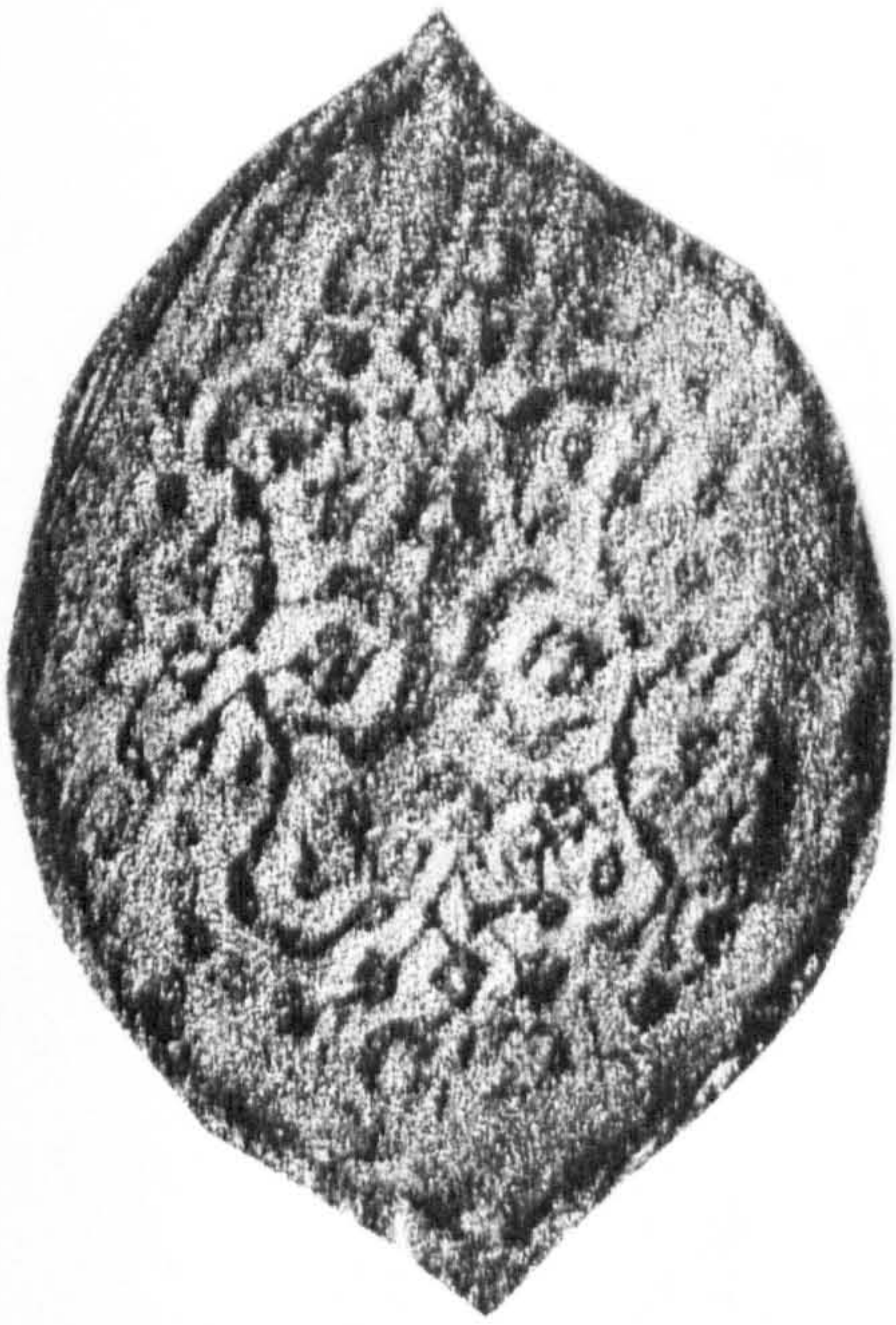

CeF35

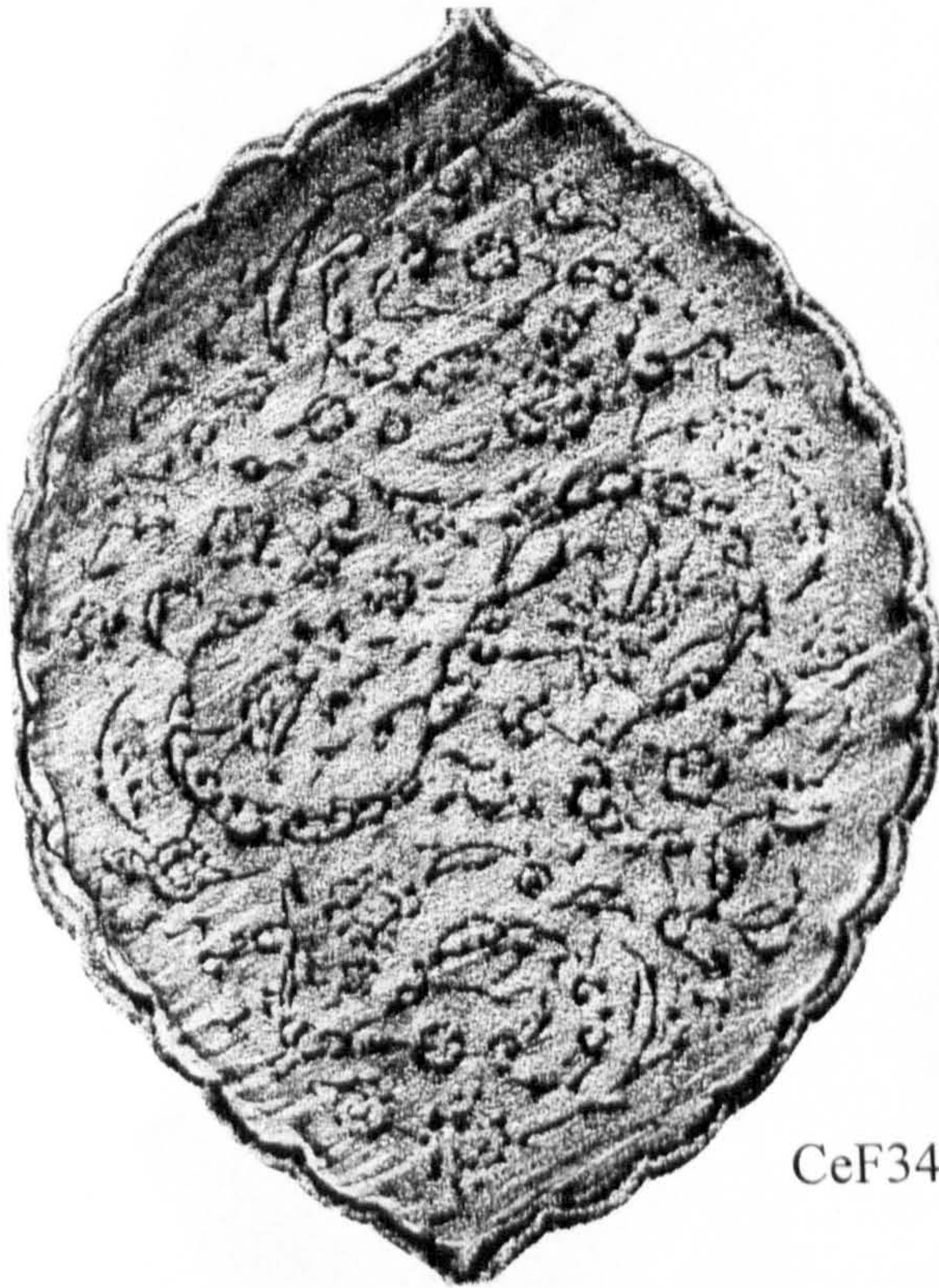

CeF34



CeF37



CeF50

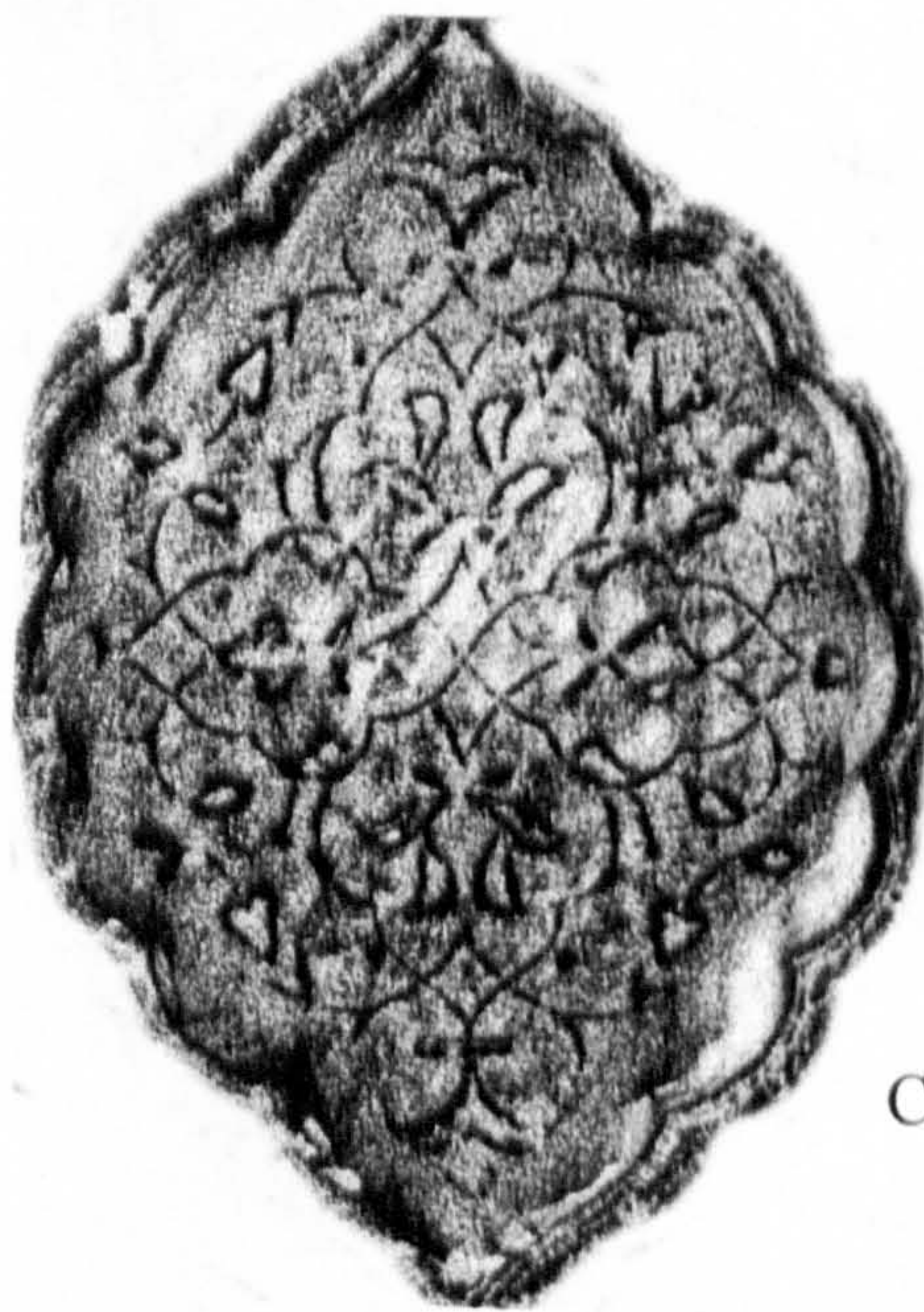

CeF49



CeF43

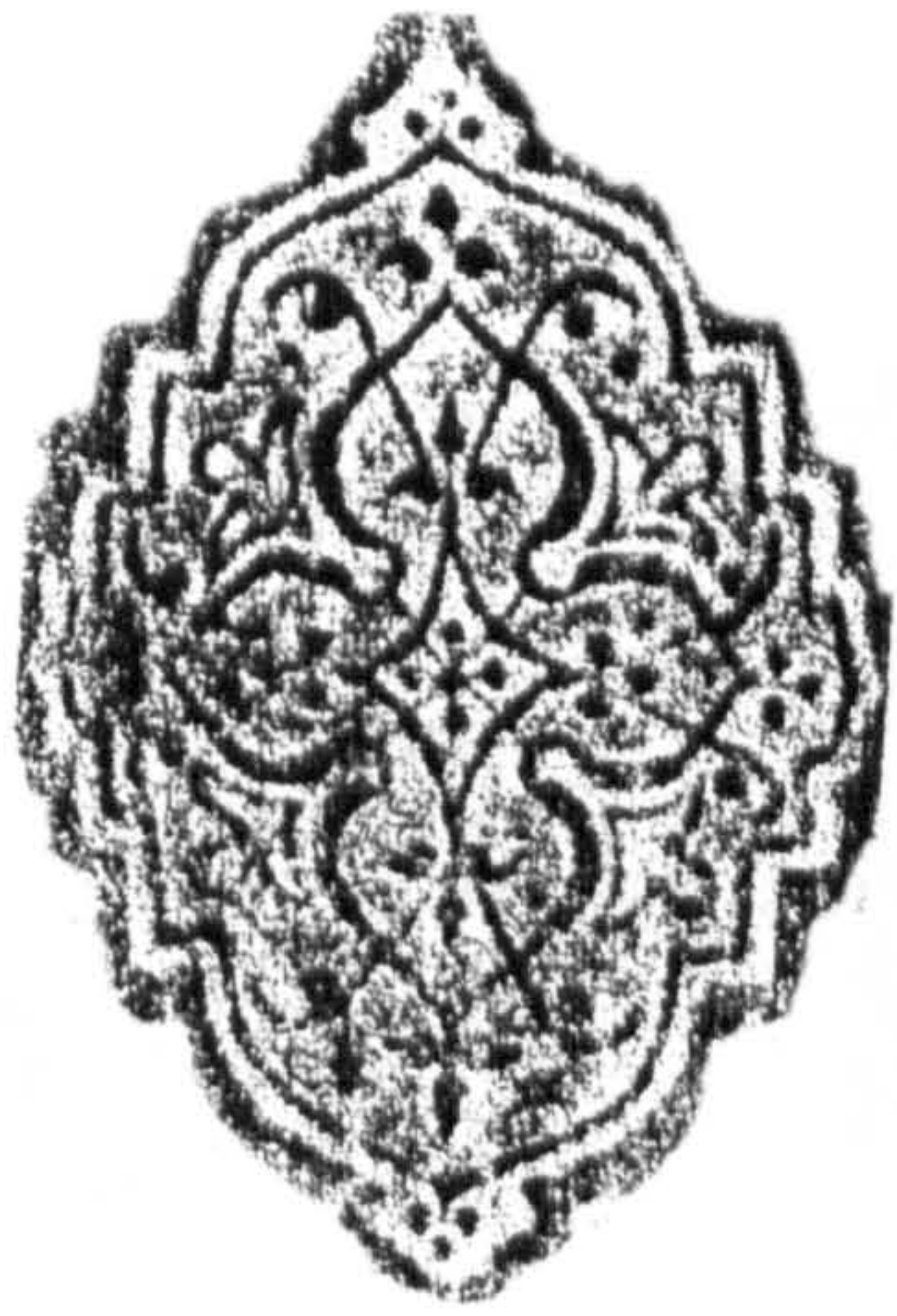

CeF1

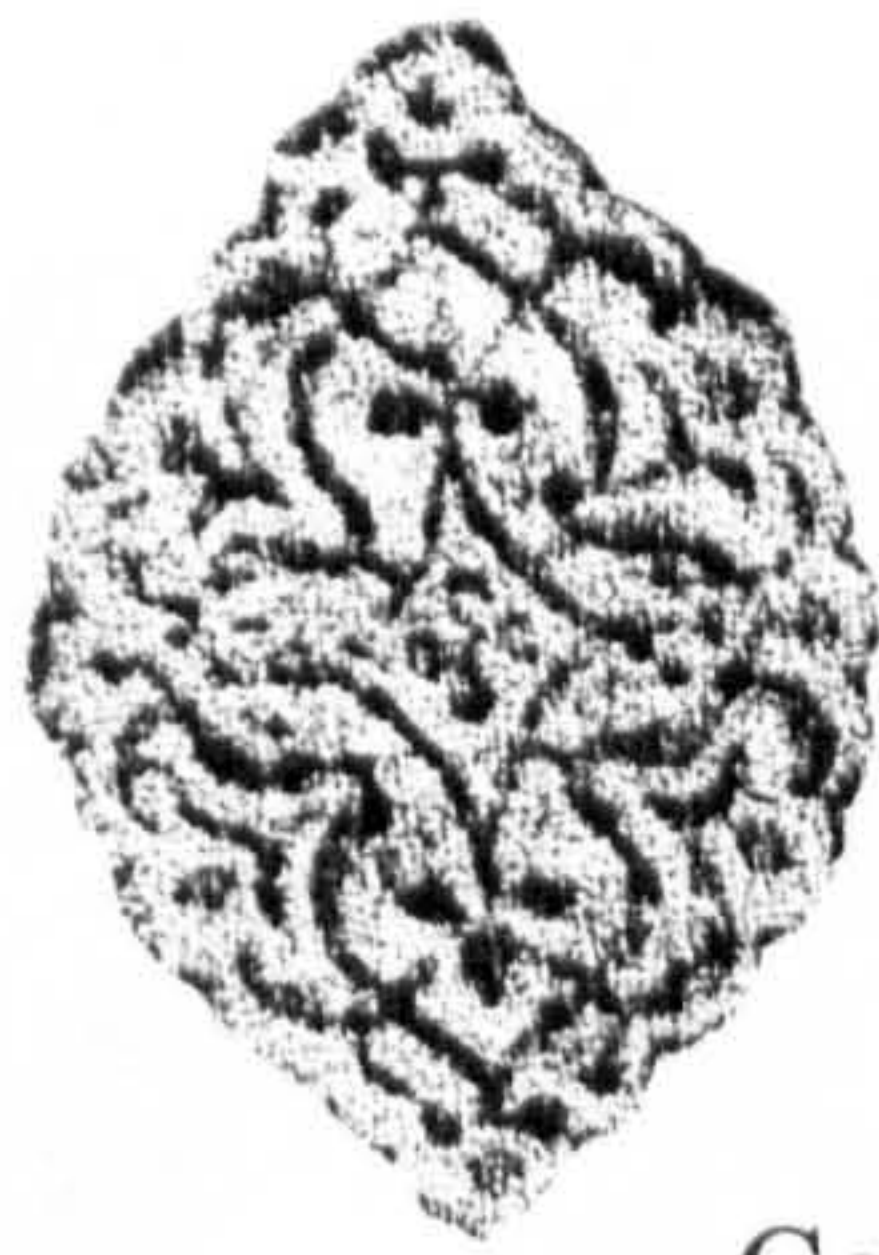

CeF29



CeF51

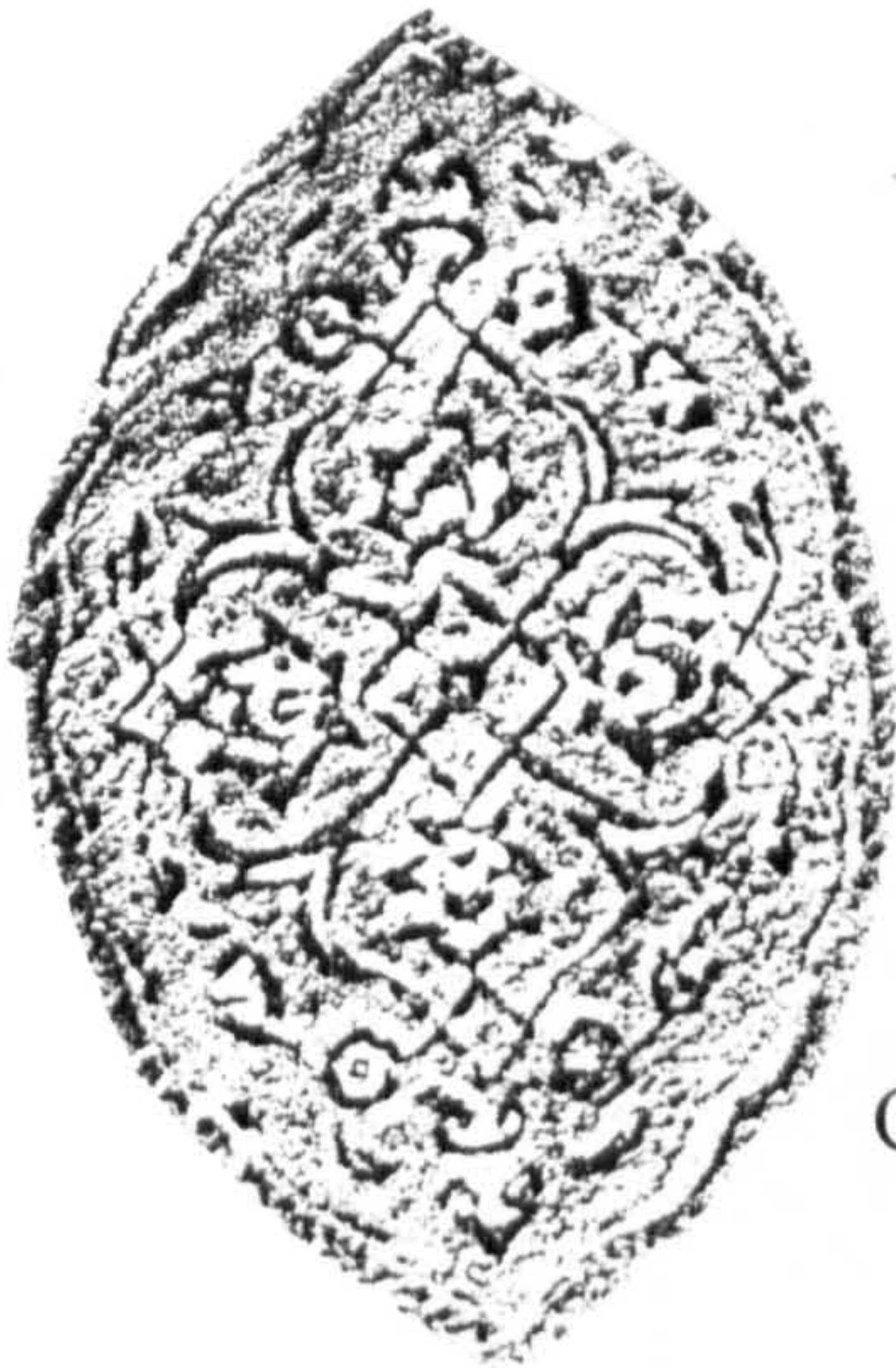

CeF39

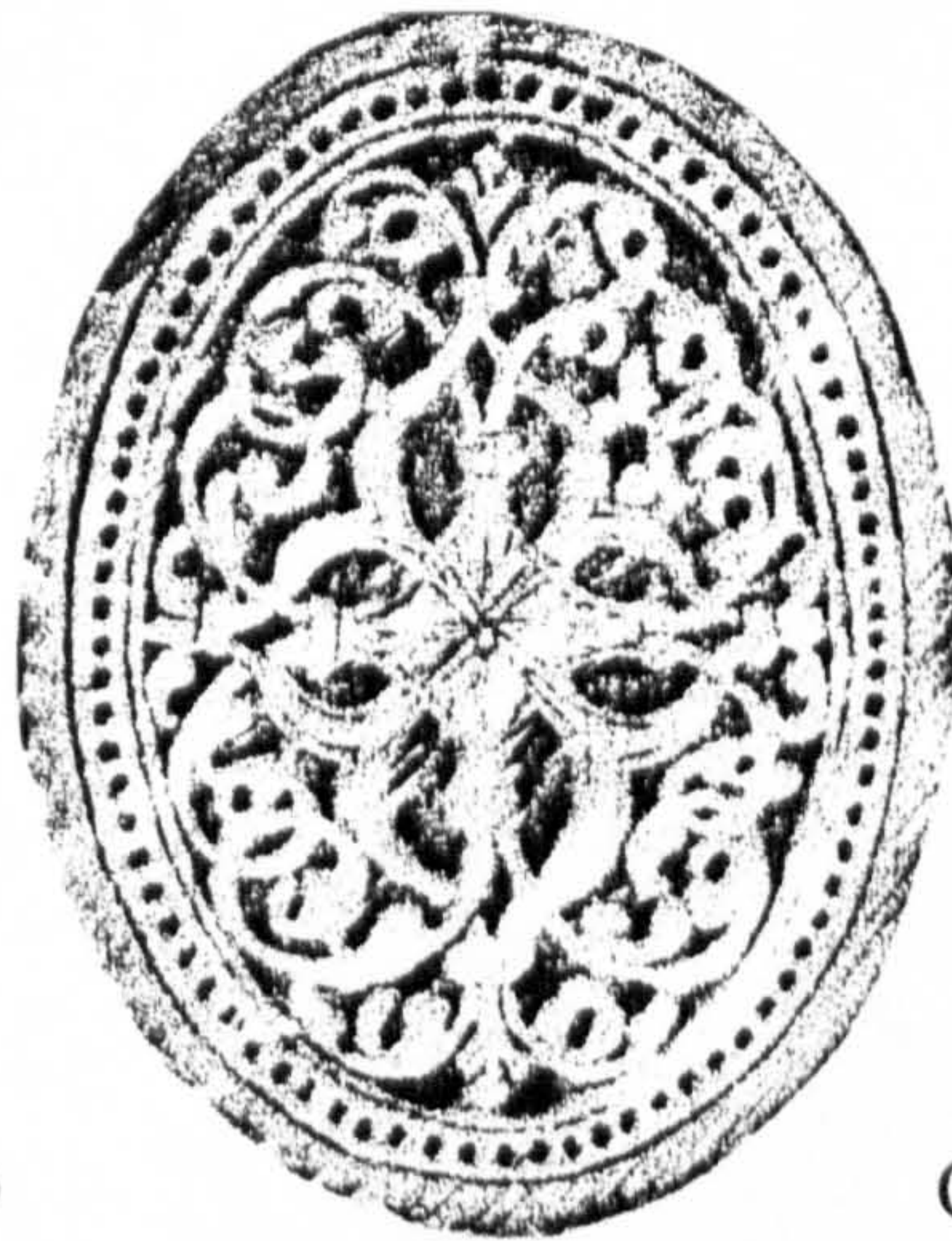

CeF6



CeF18

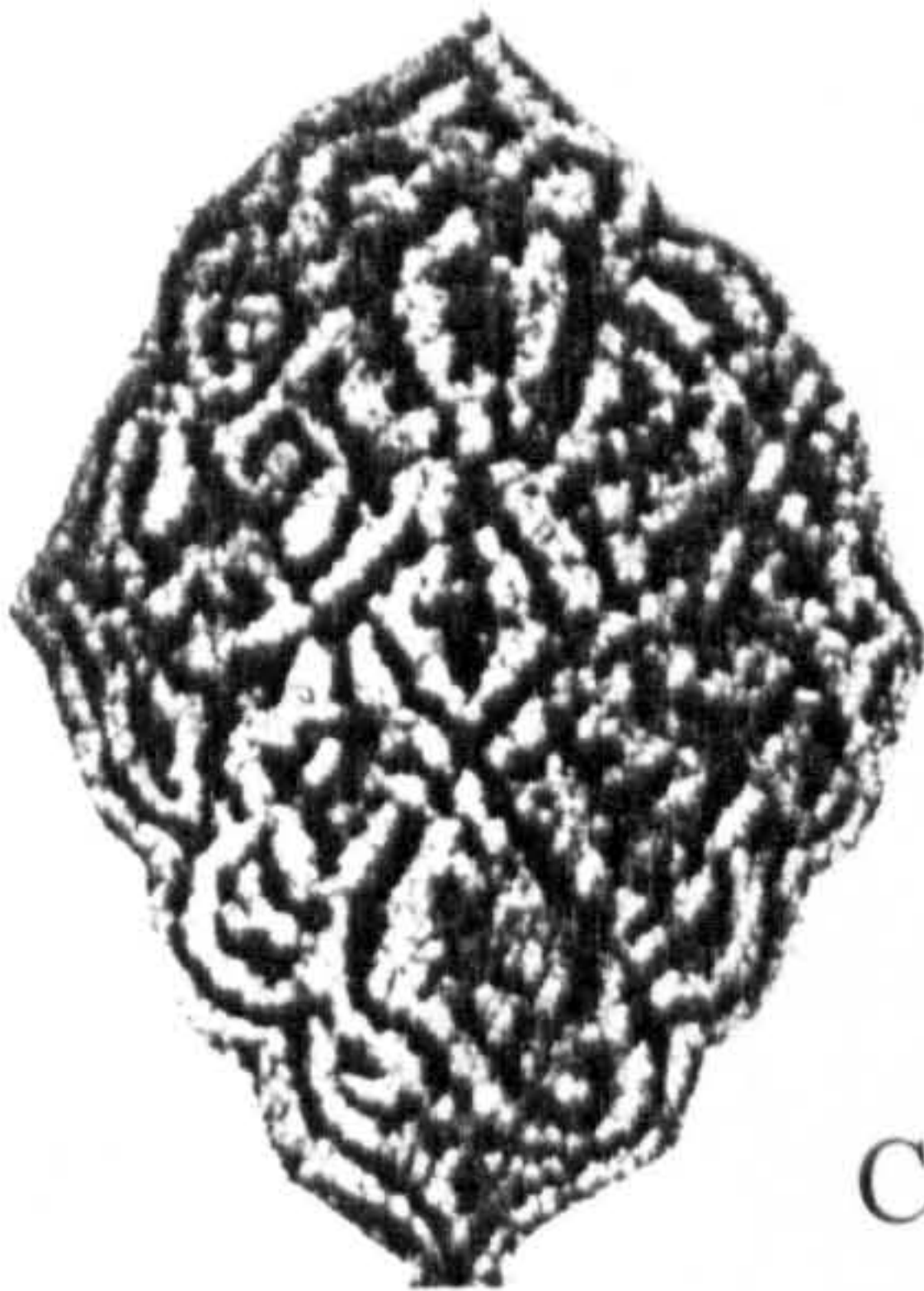

CeF54



CeF32



CeF22



CeF26



CeF27



CeF53

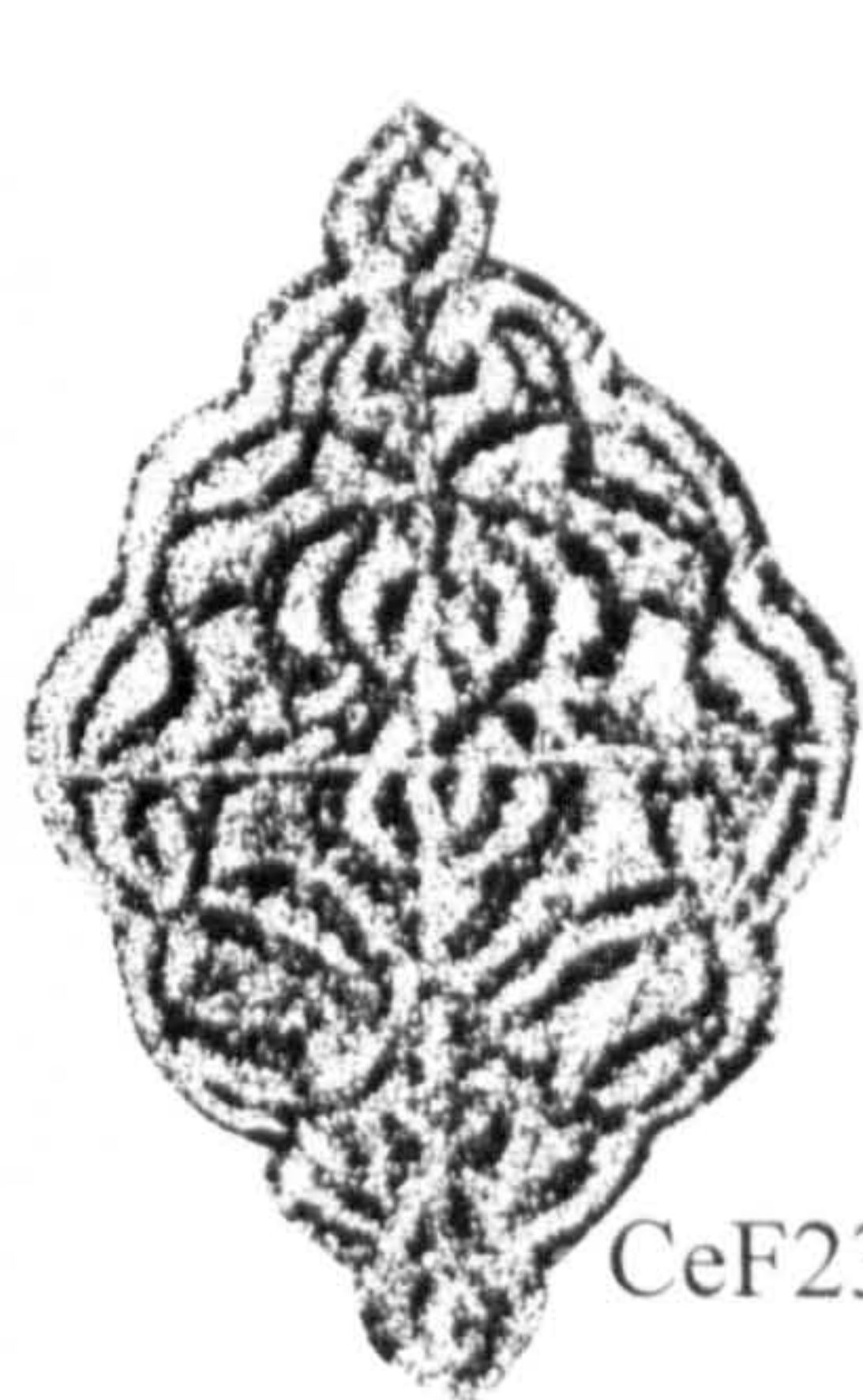

CeF23



CeF24

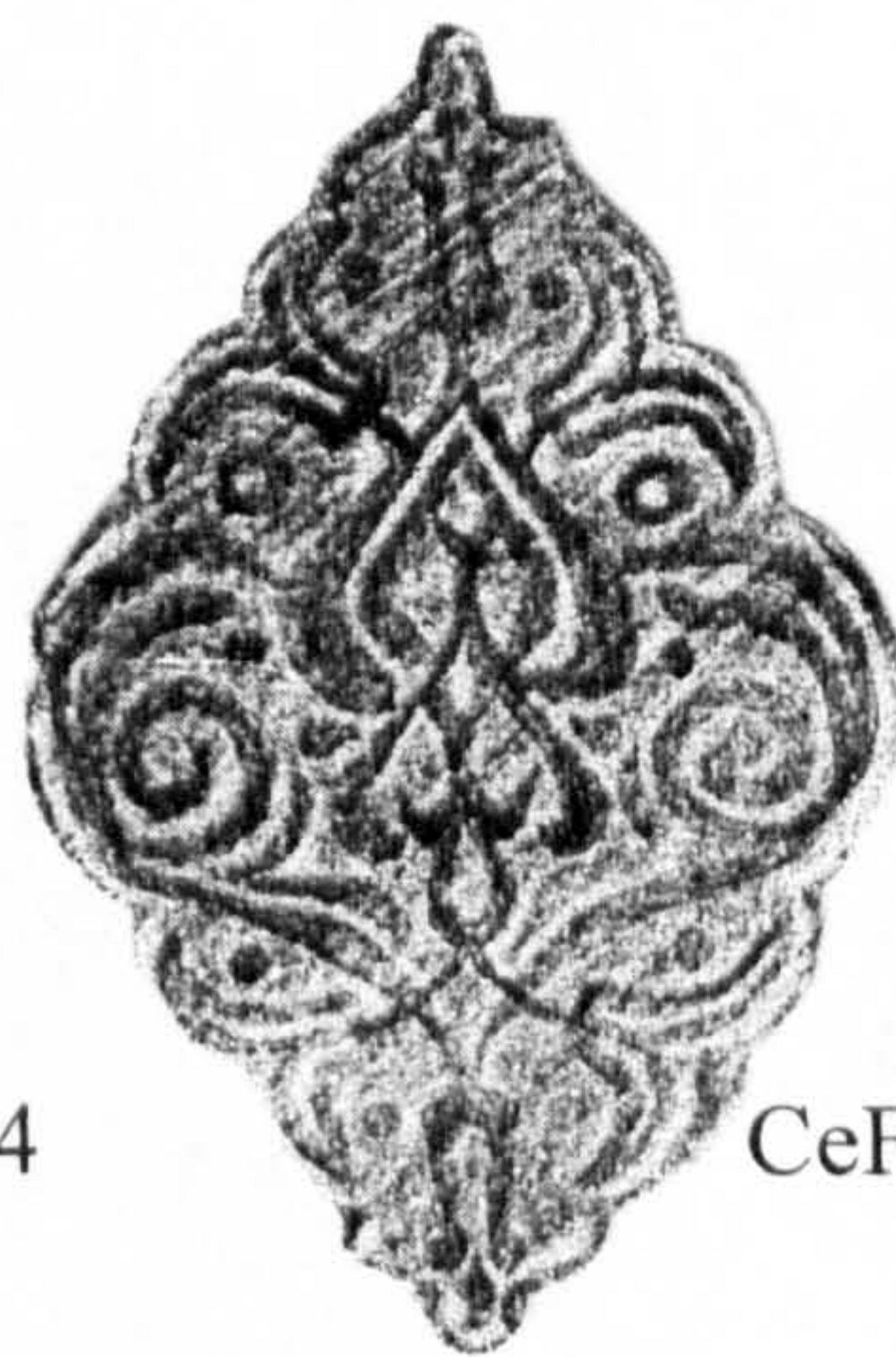

CeF25



CeF28



CeF9



CeF46



CeF4



CeF2

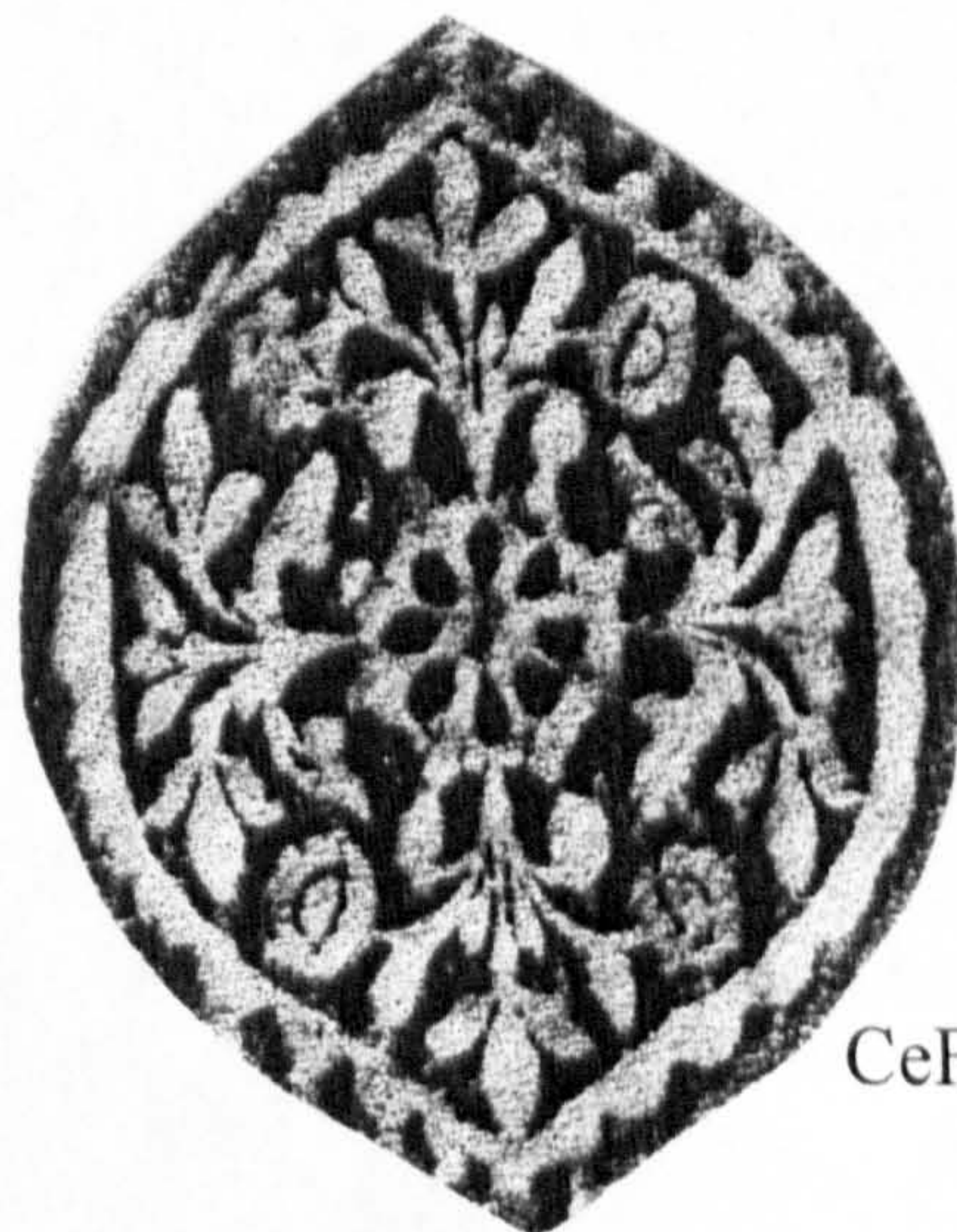

CeF16



CeF44



CeF56



CeF17



CeF36

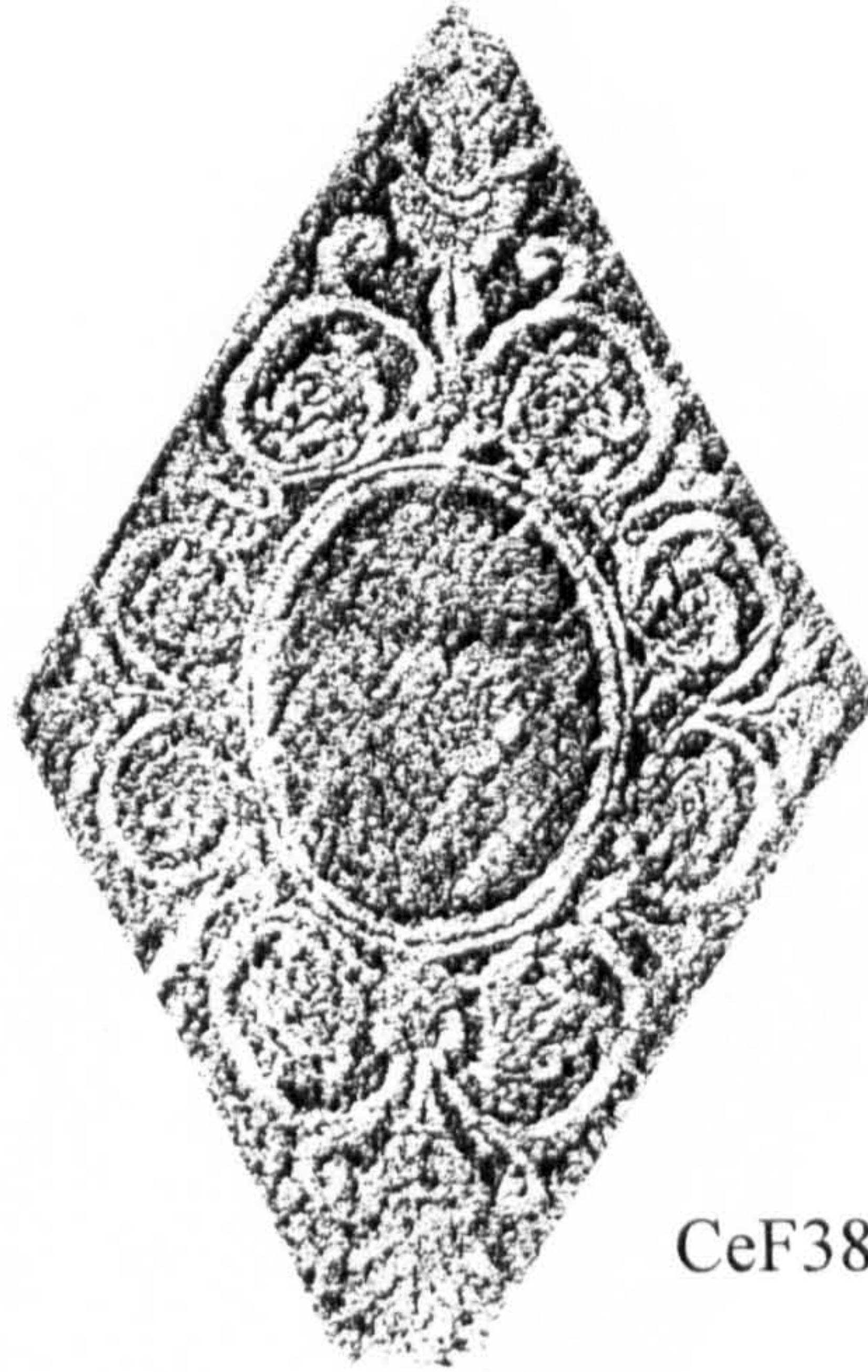

CeF38

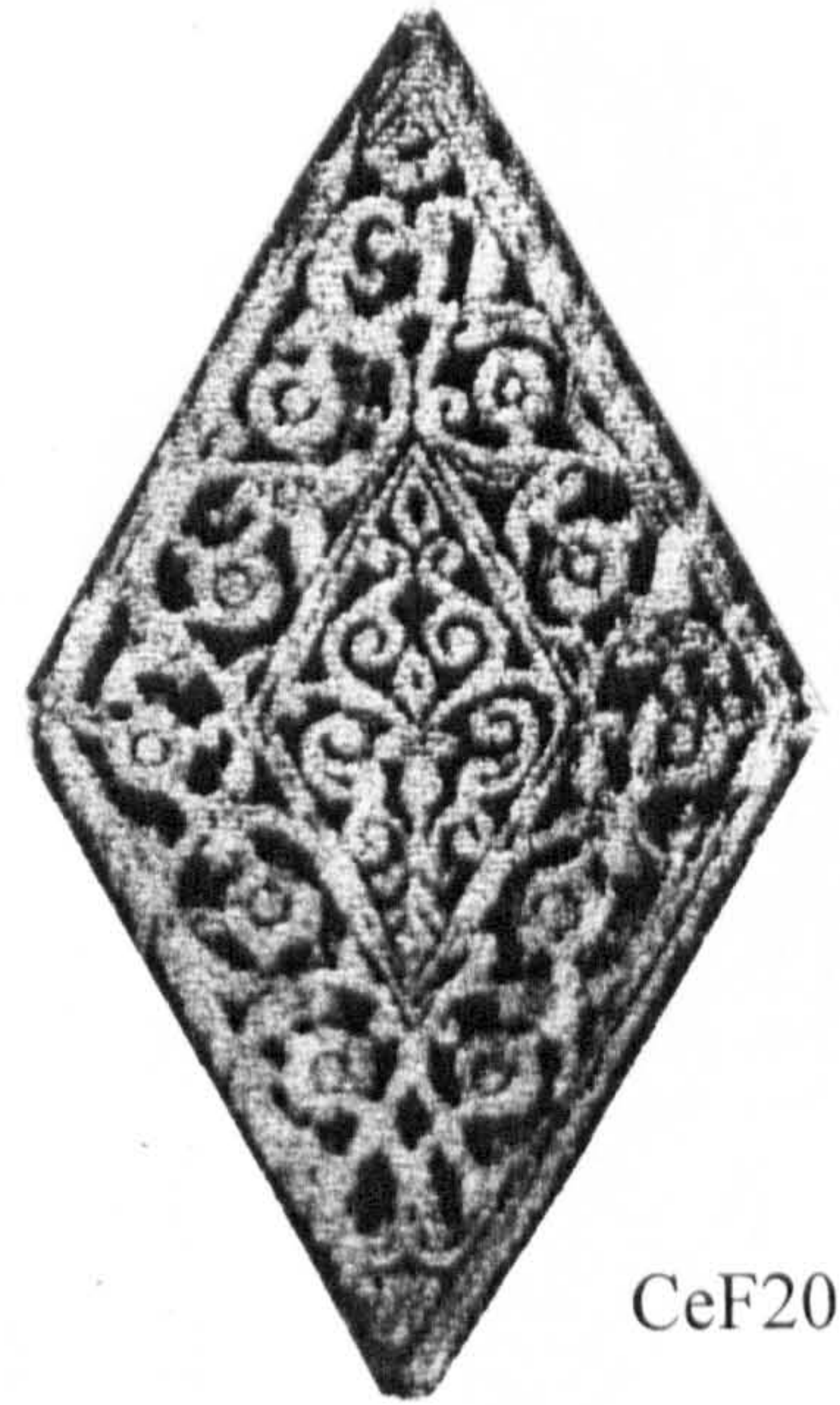

CeF20

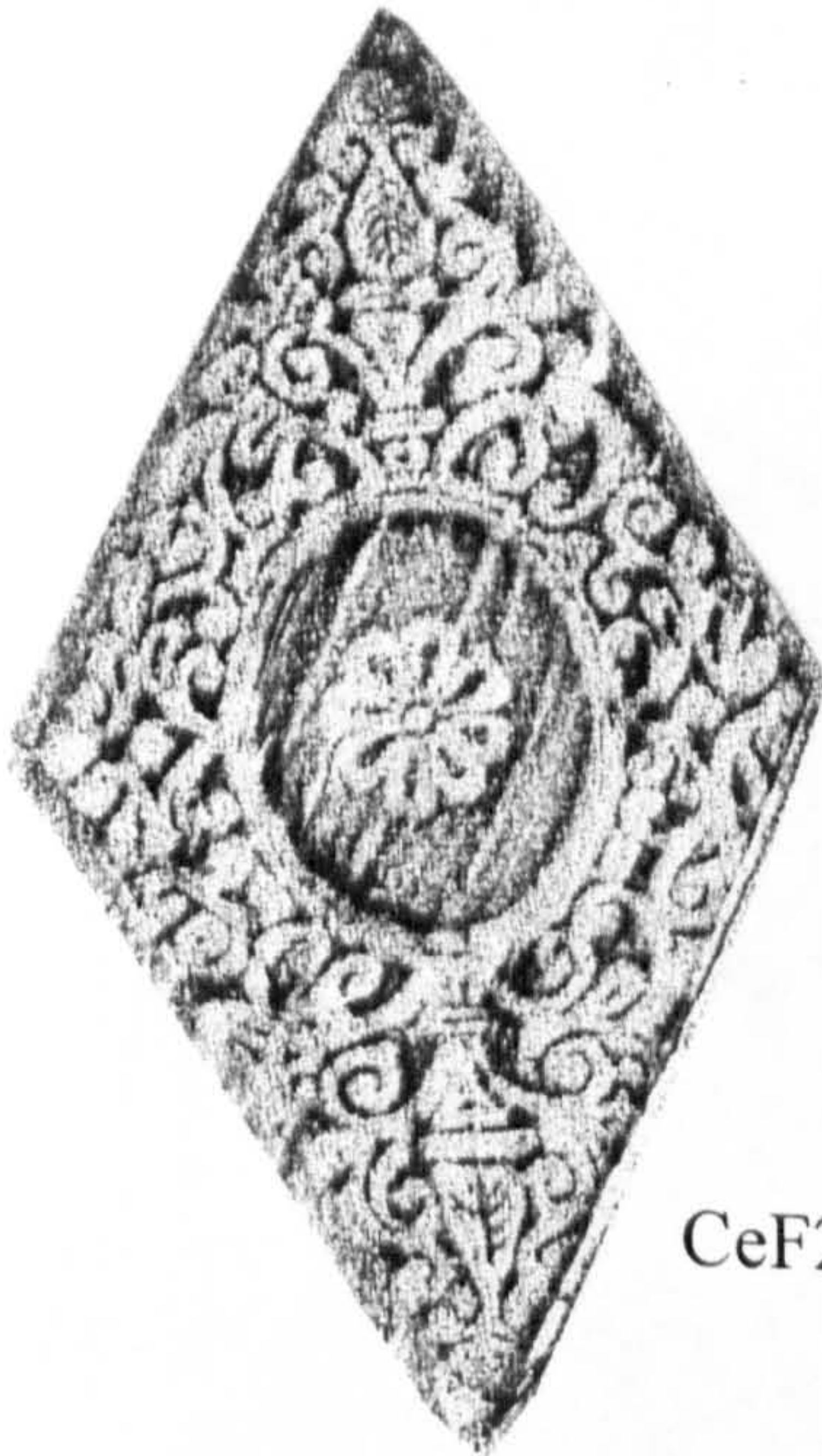

CeF21

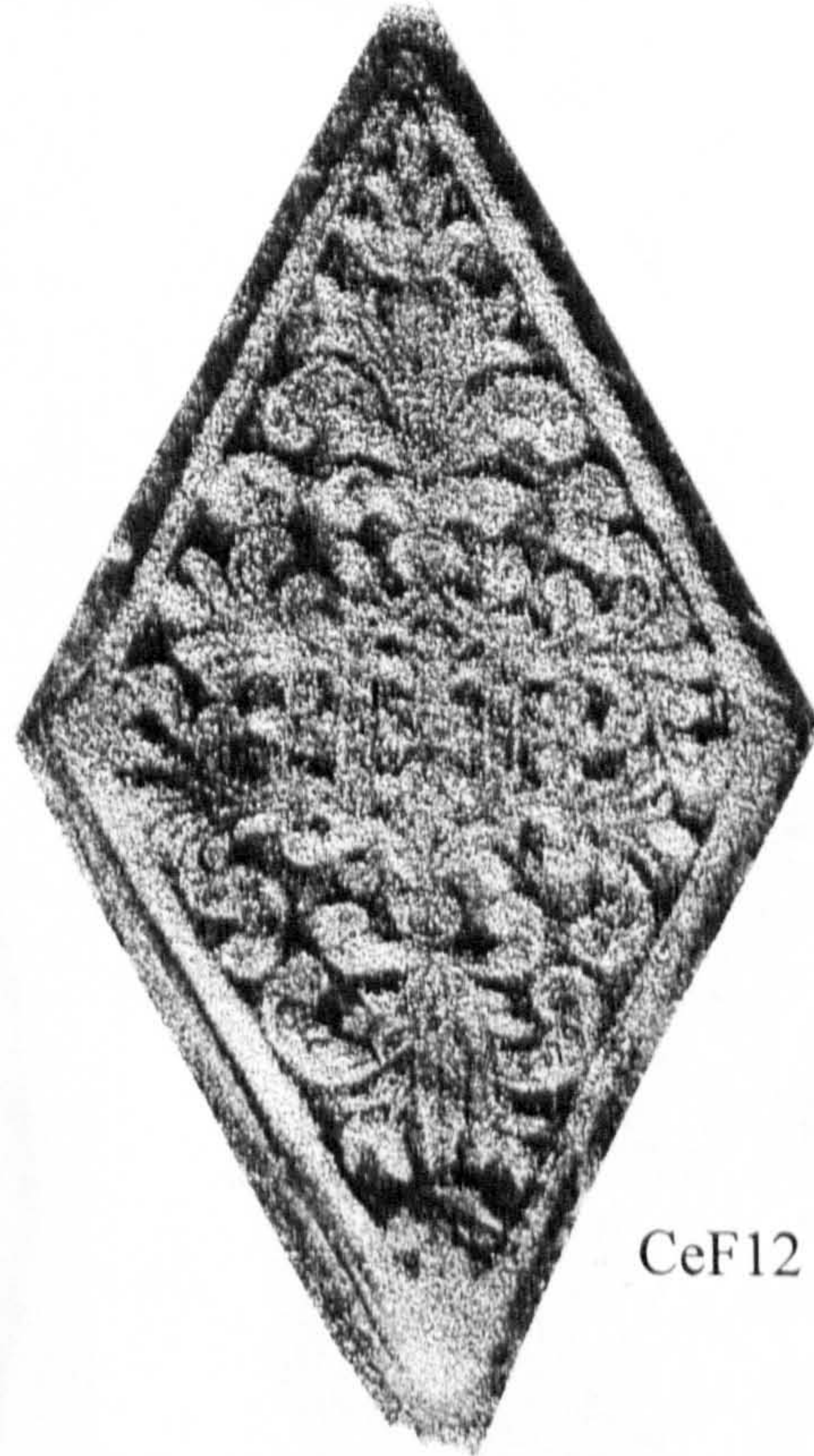

CeF12



CeF47



CeF52

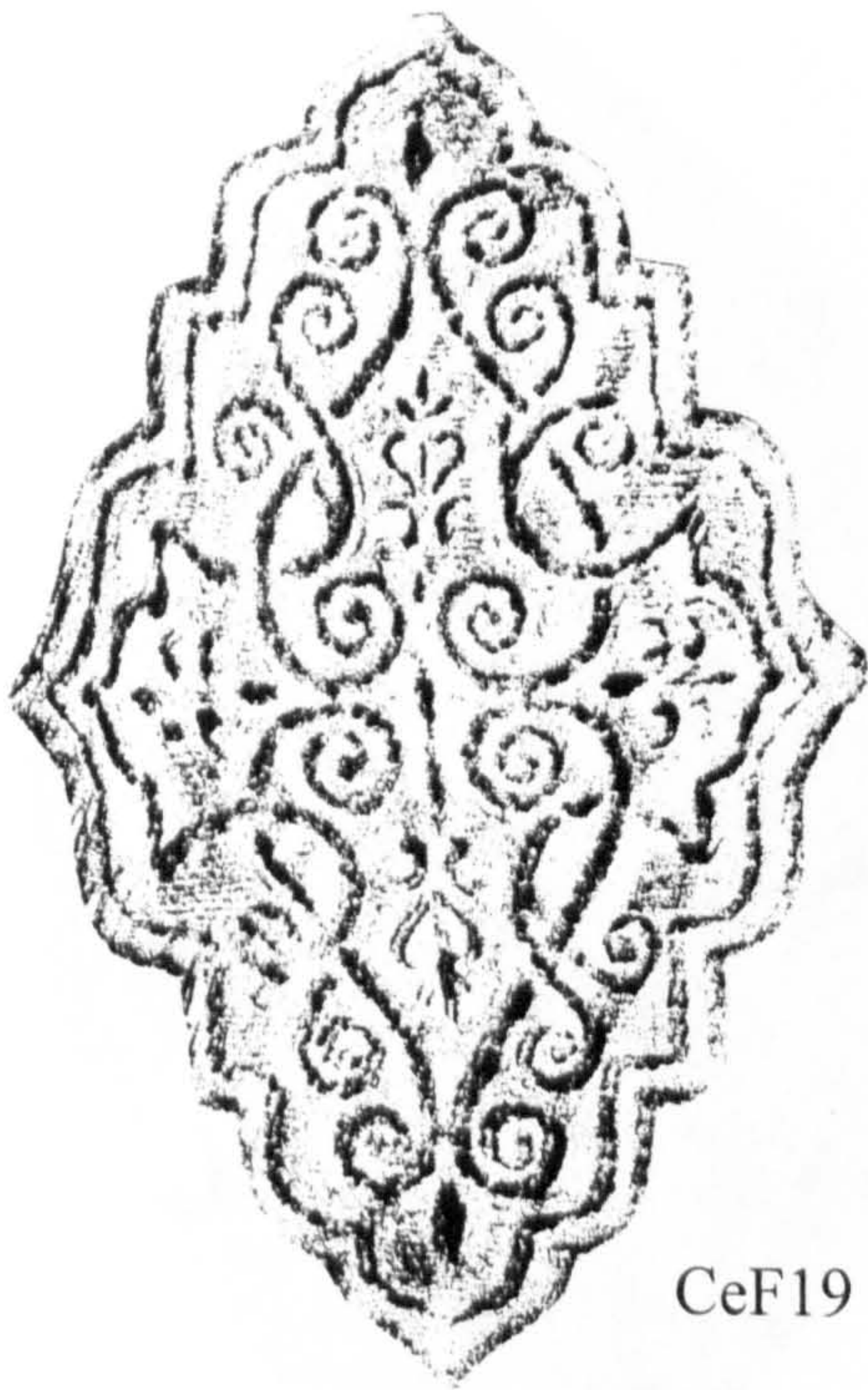

CeF19

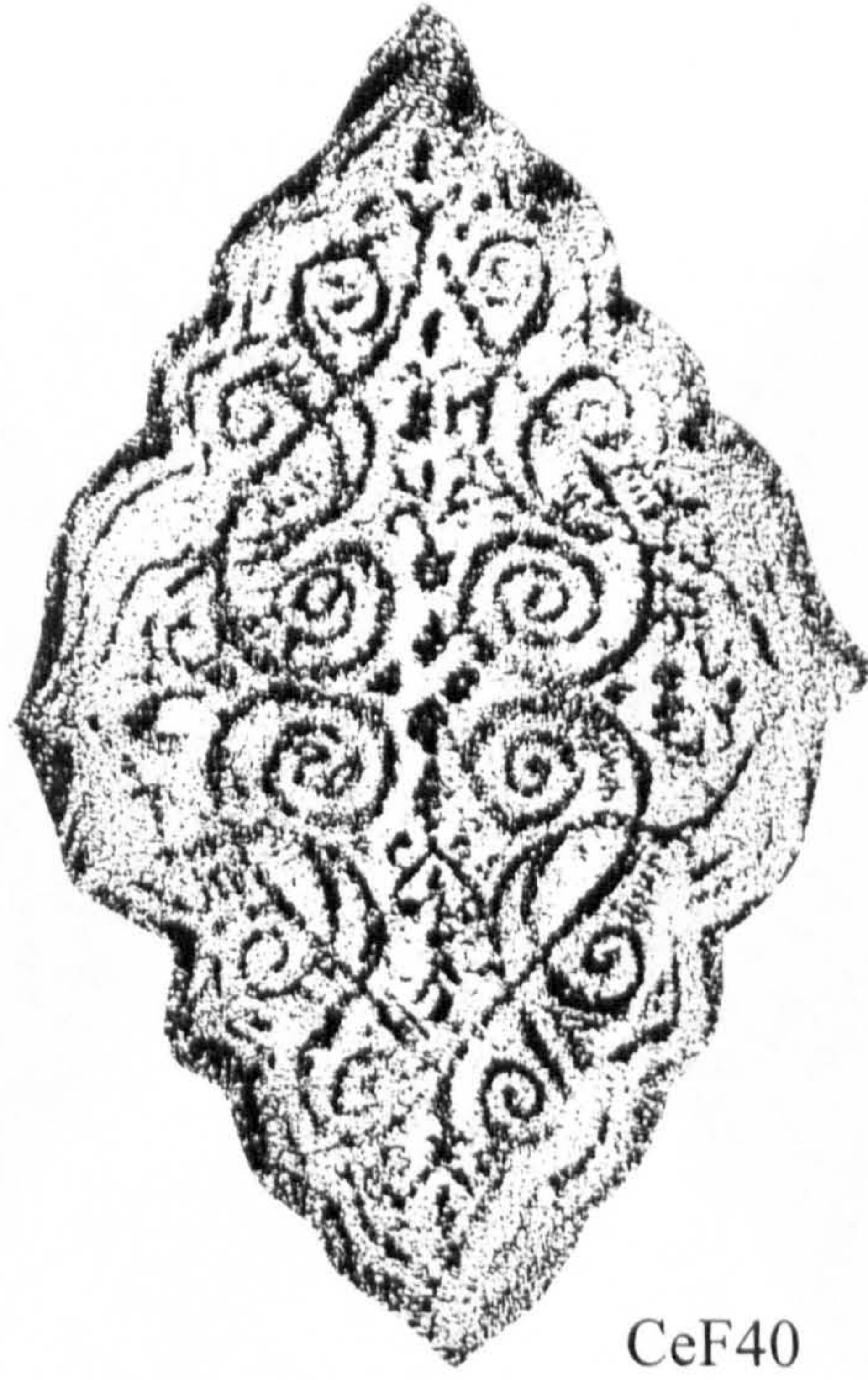

CeF40

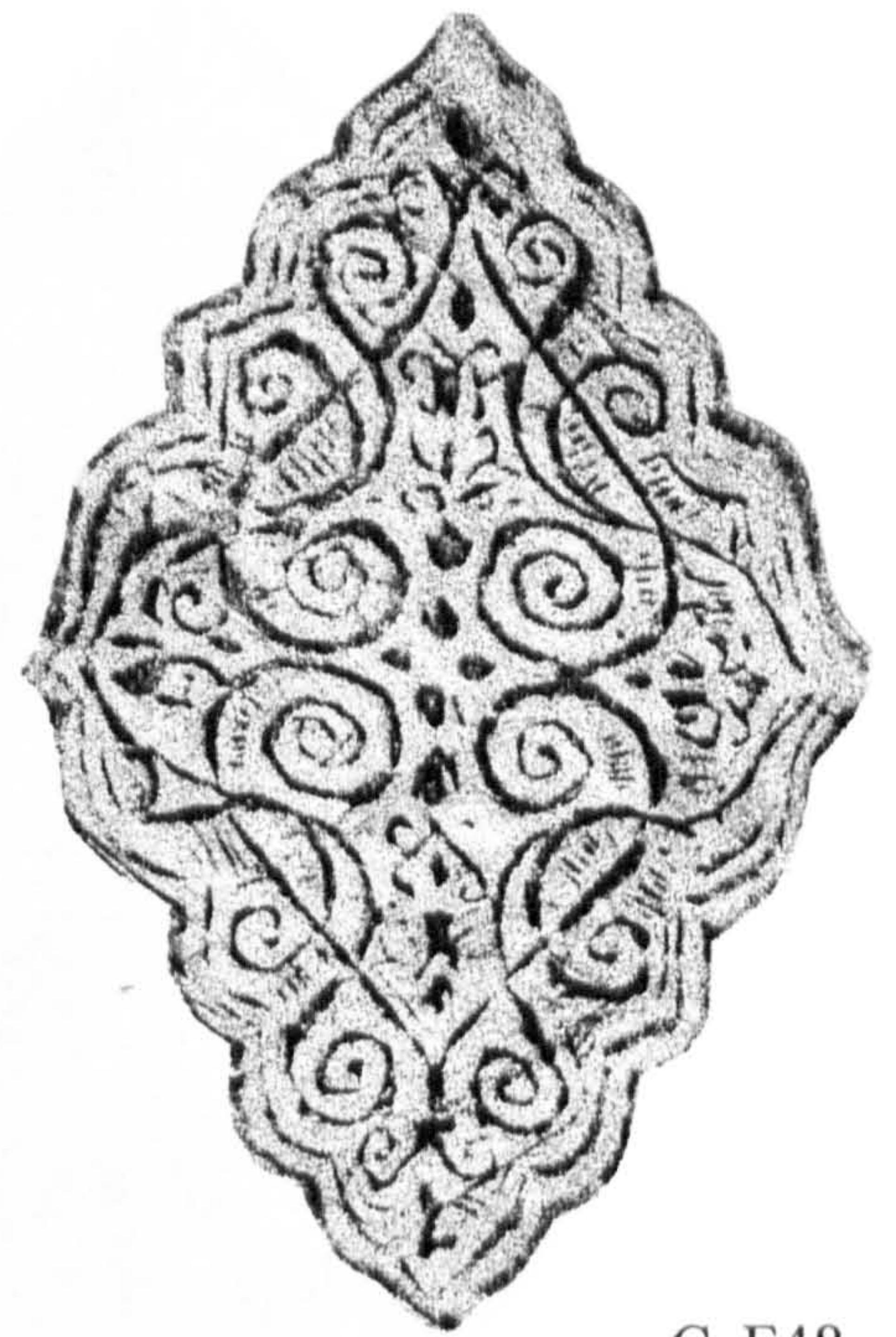

CeF48

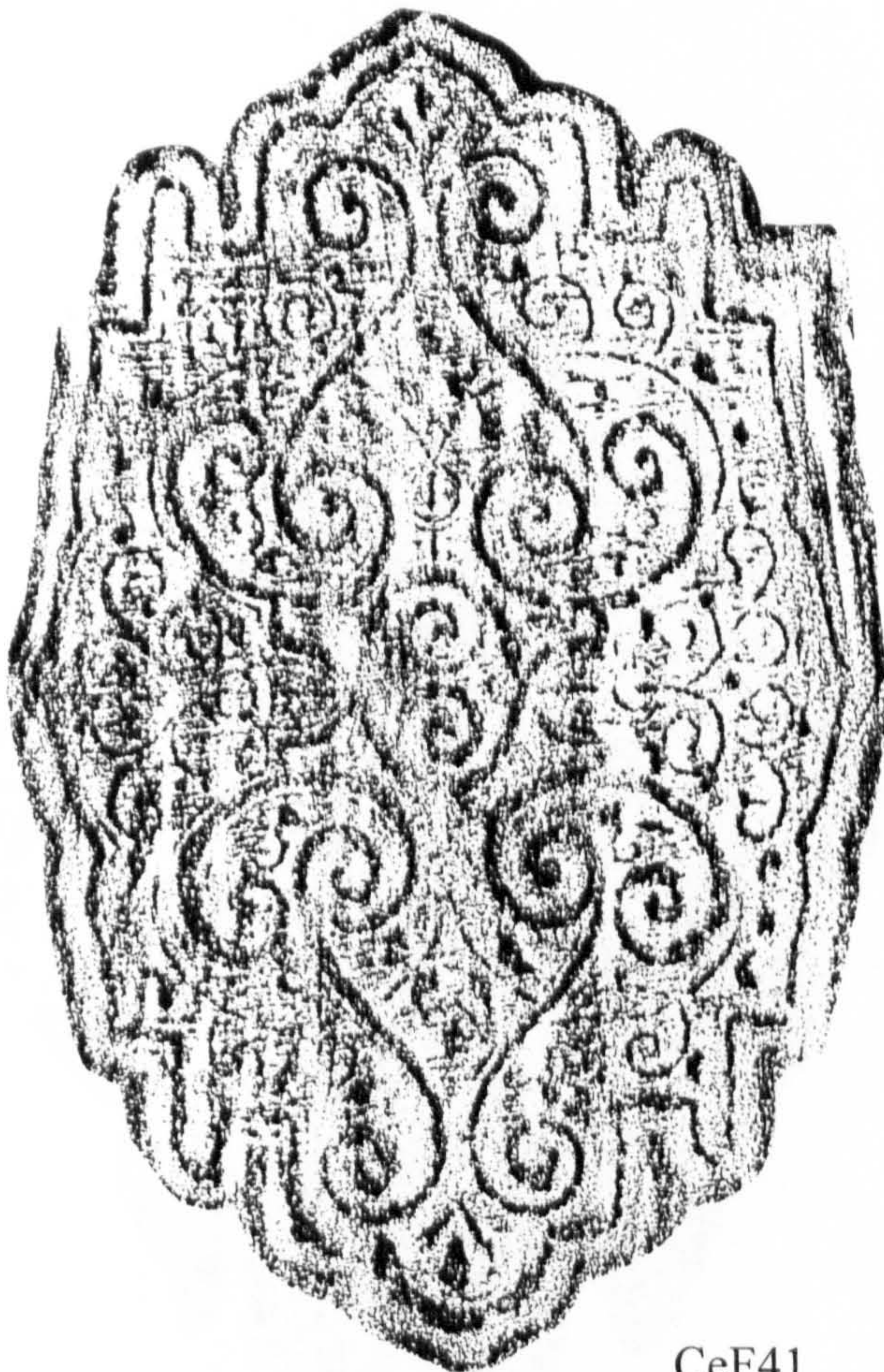

CeF41



CeF55





CeF7



CeF8



CeF10

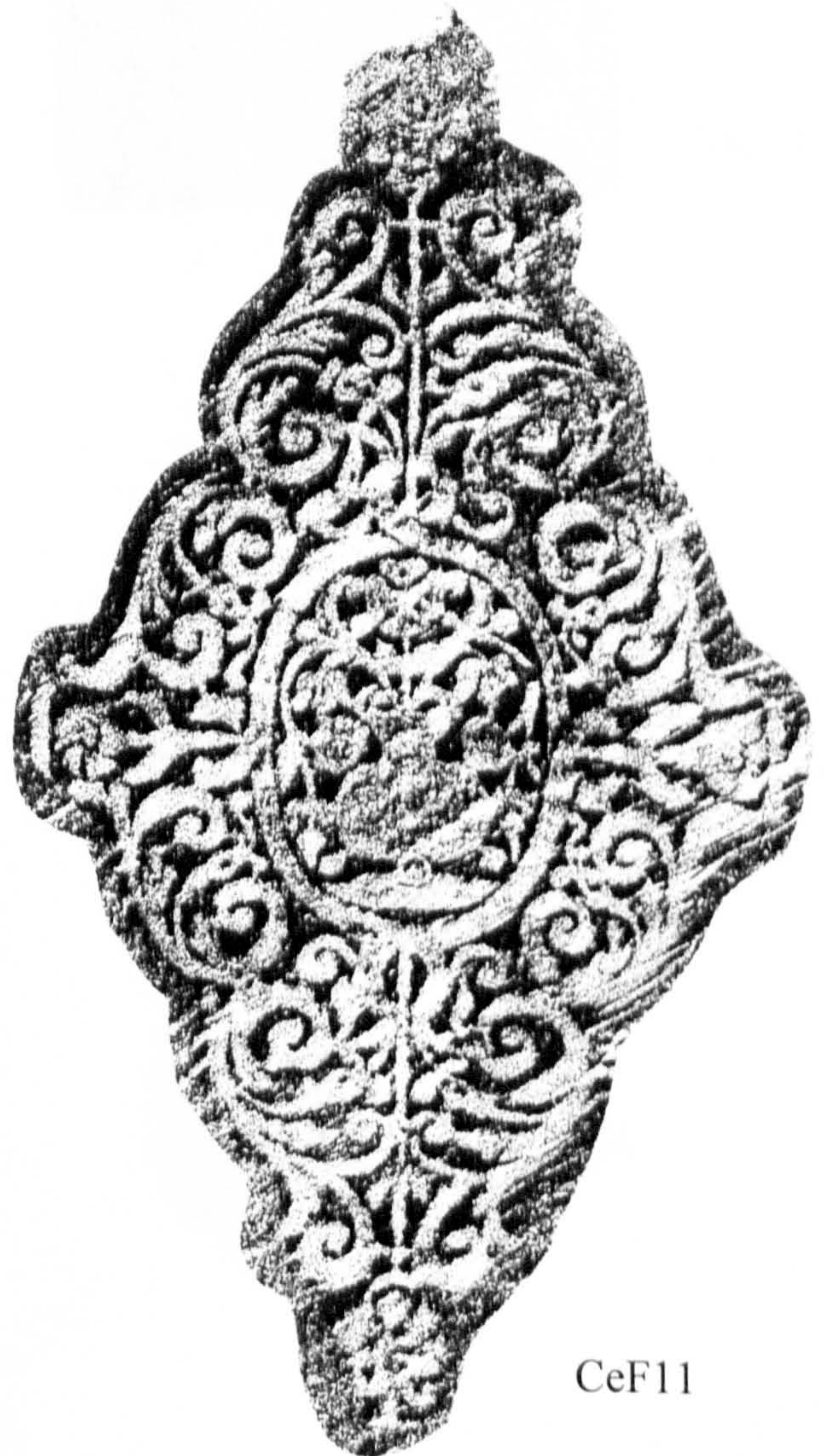

CeF11

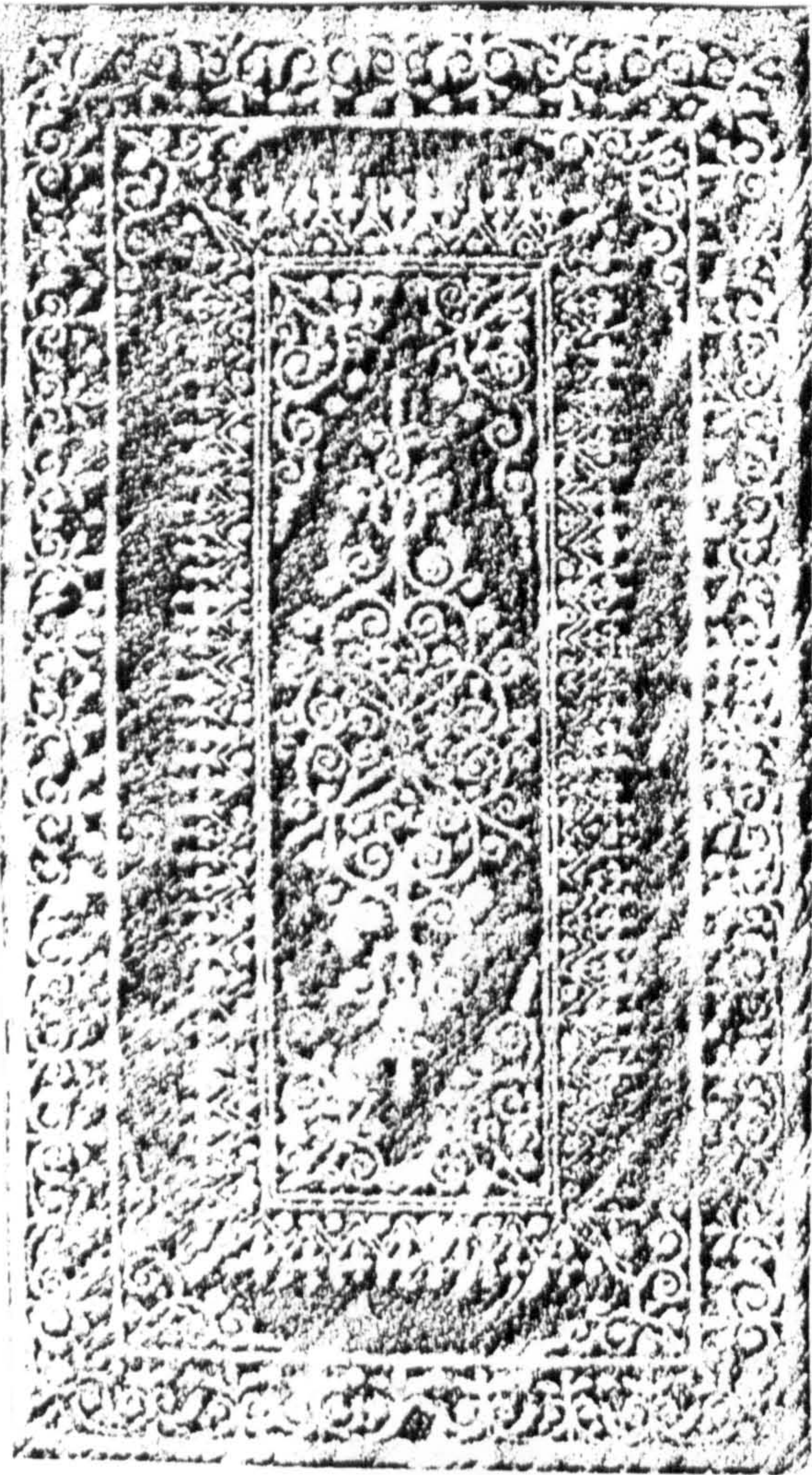

CeF42



CeF57



CeF43



CeF58



CeF54

CER



CeR18



CeR5

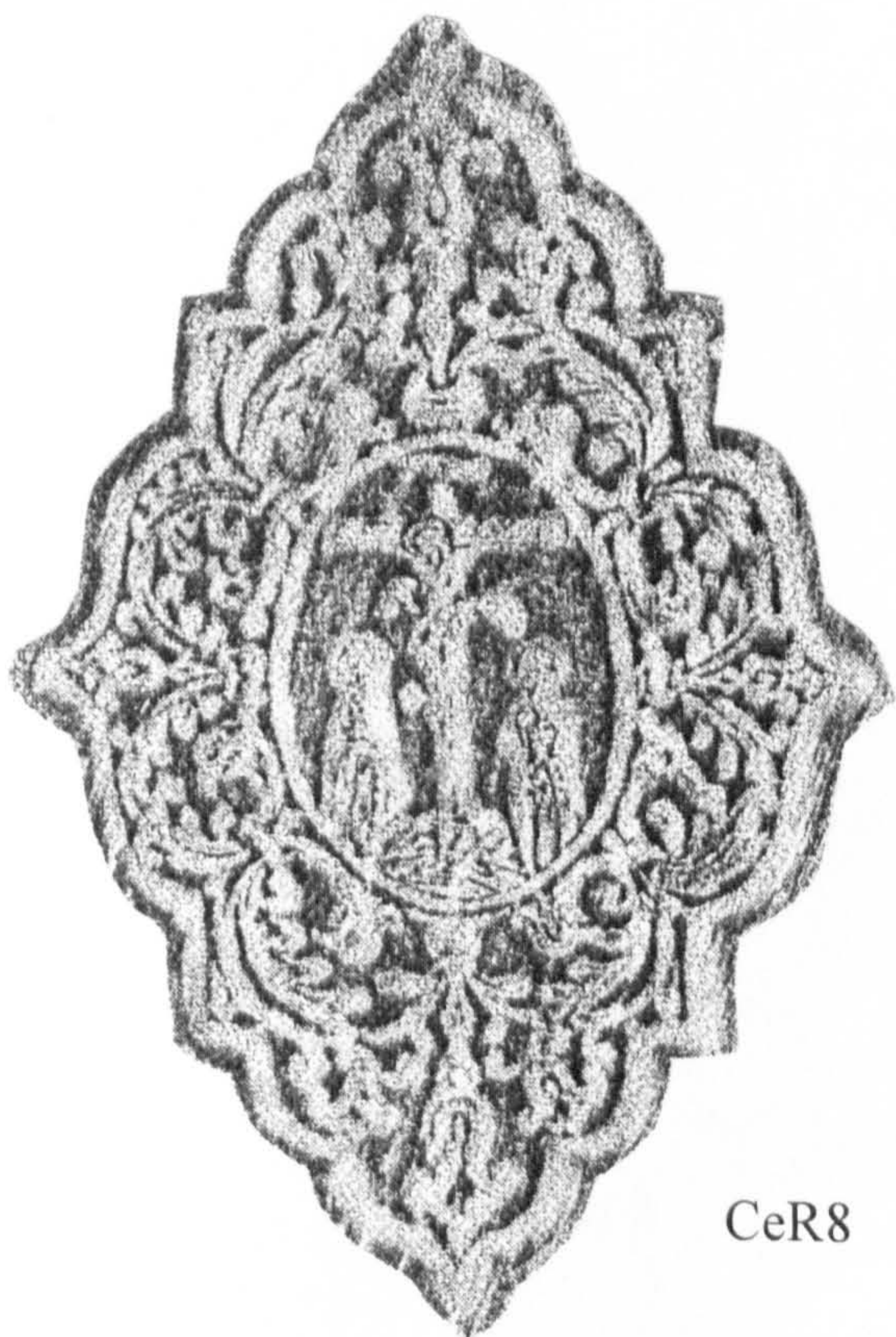

CeR8



CeR9



CeR39

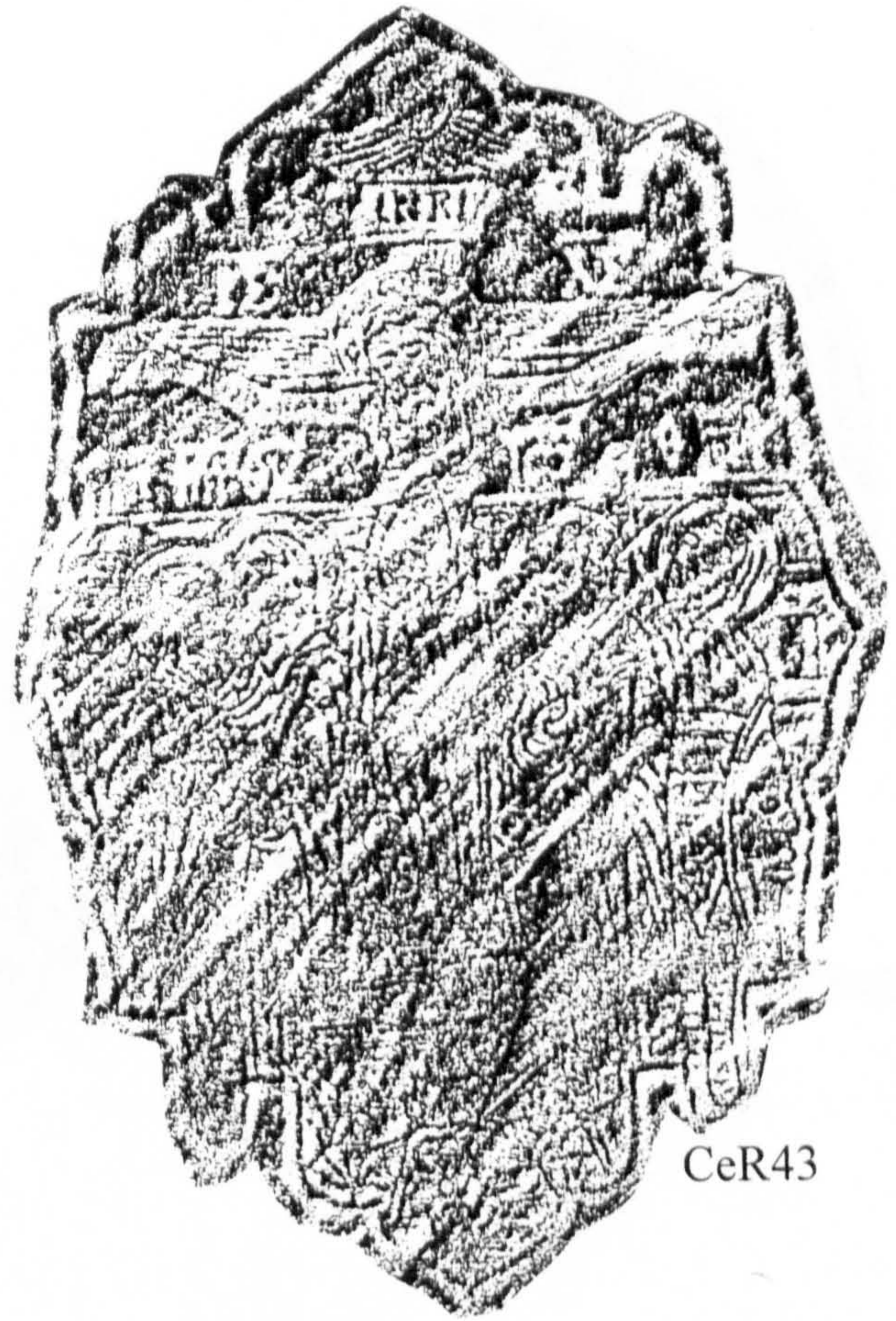

CeR43



CeR45



CeR48



CeR22



CeR34



CeR23



CeR37



CeR38

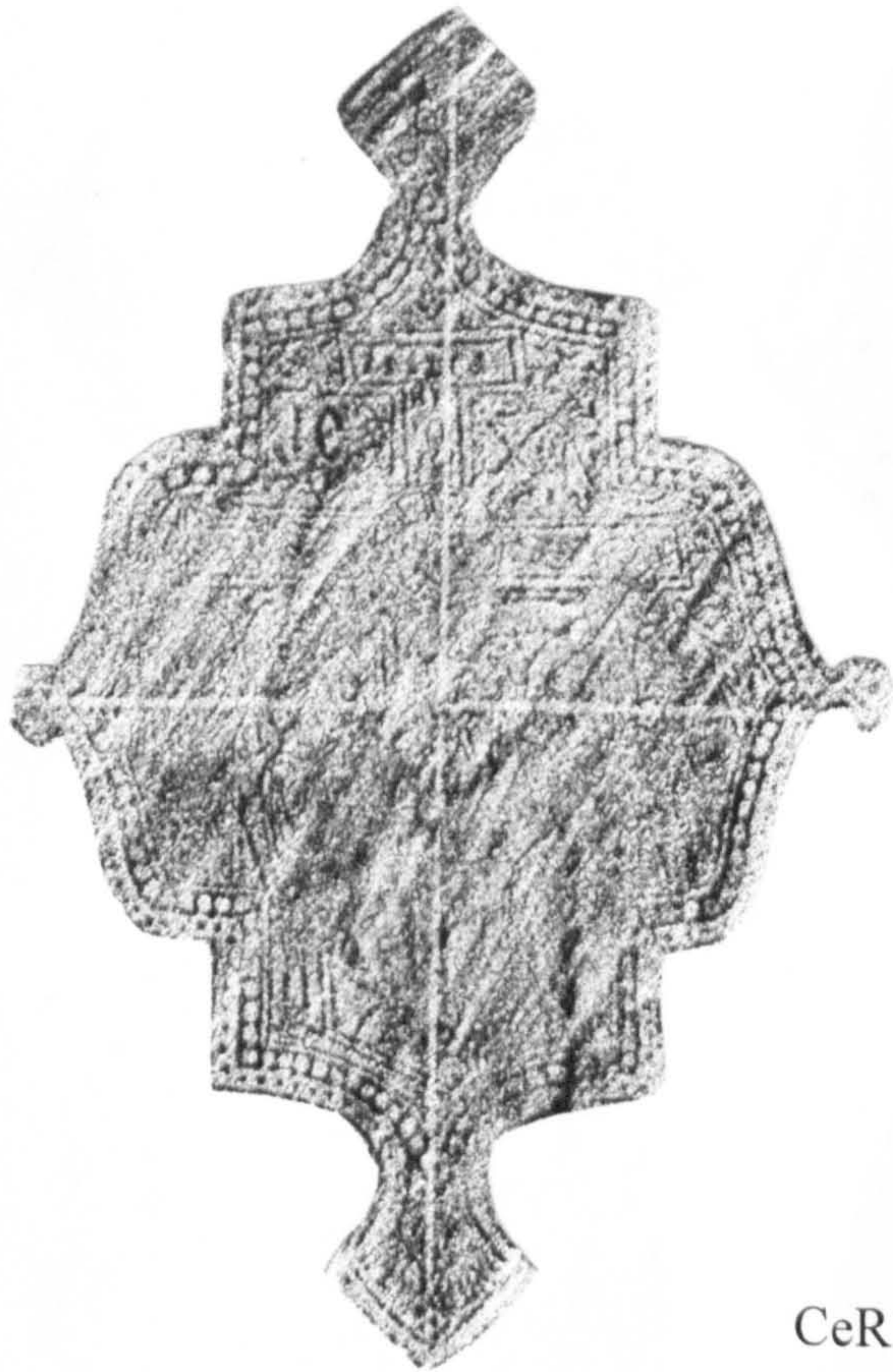

CeR19



CeR41



CeR20



CeR21

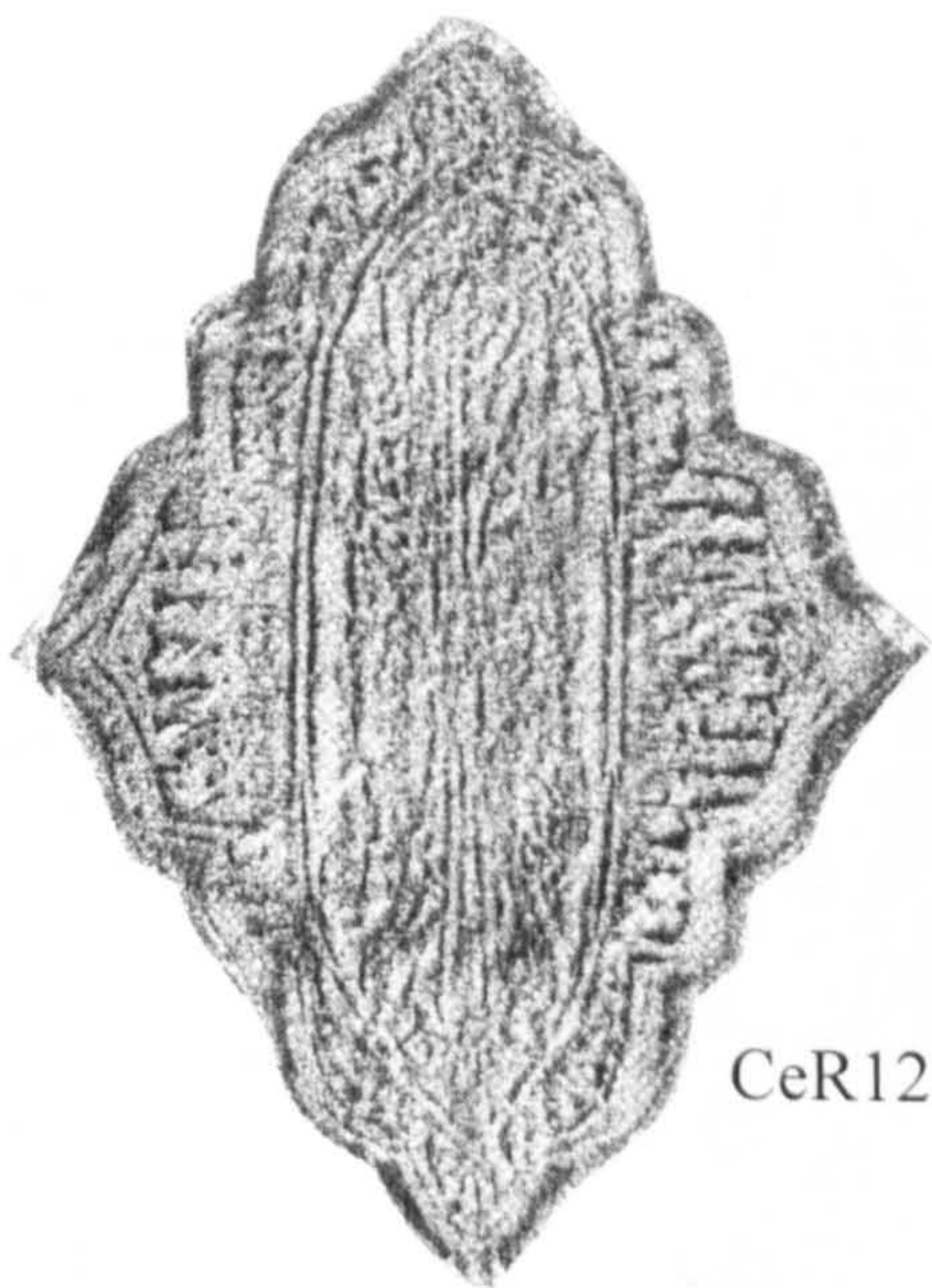

CeR12

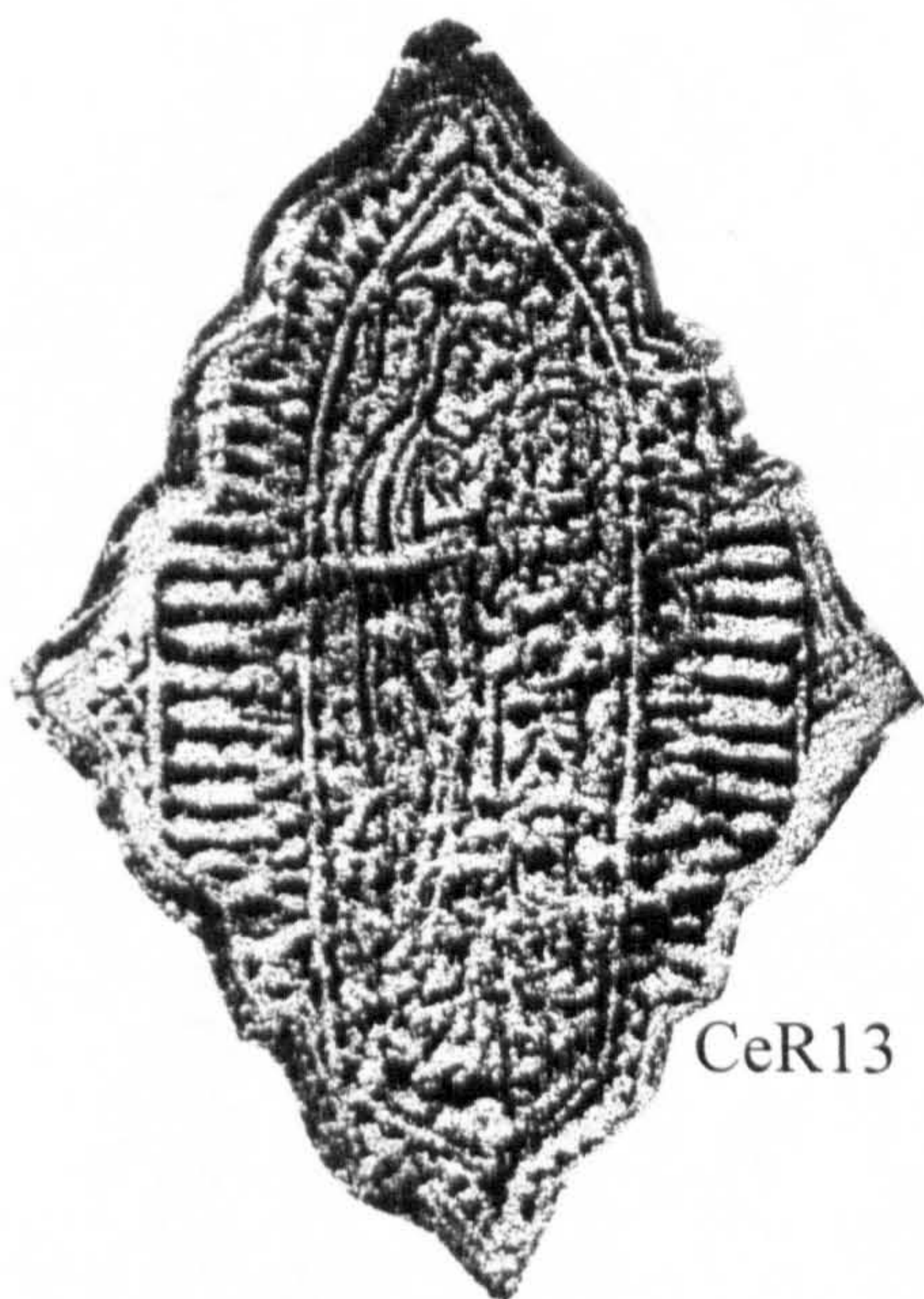

CeR13

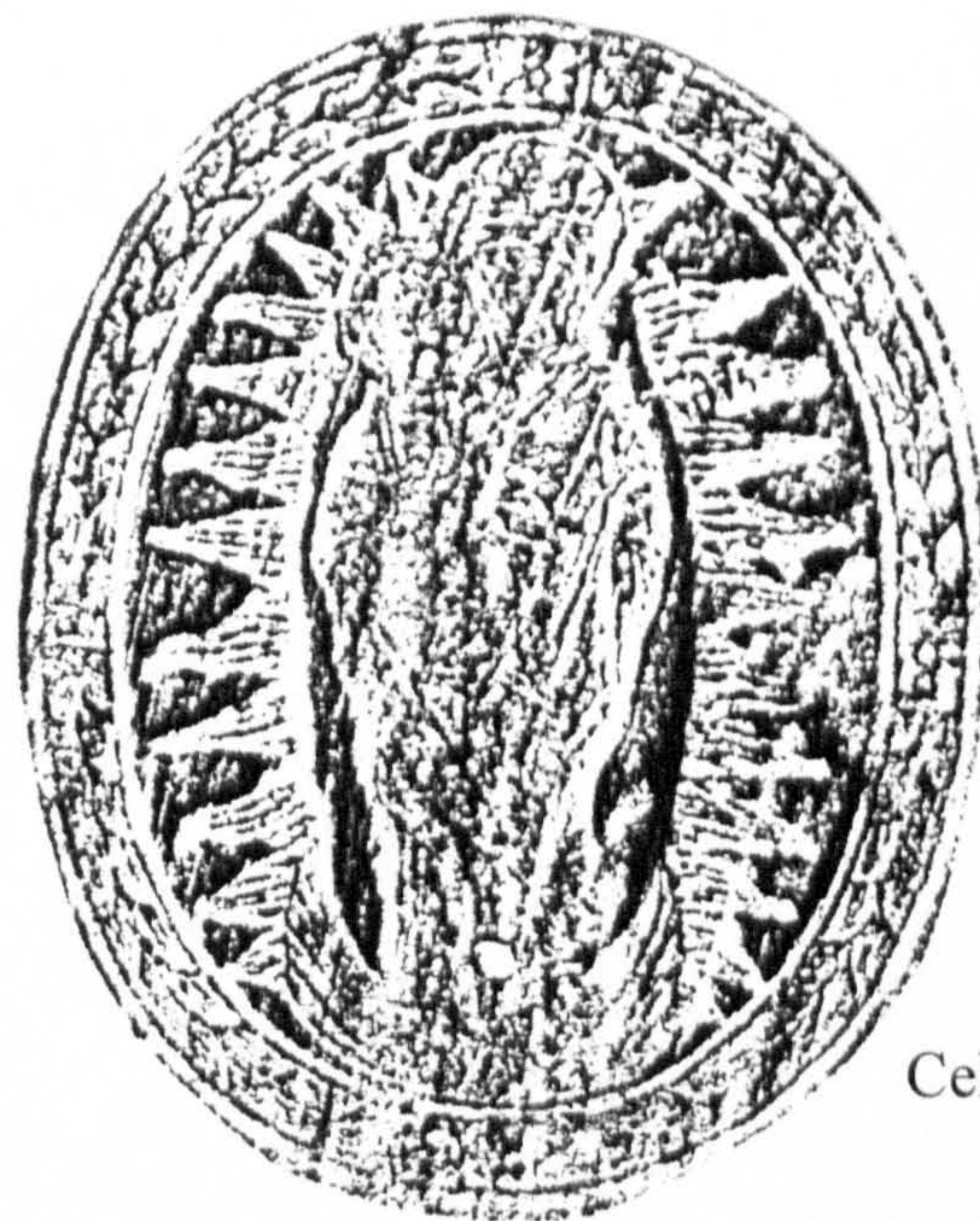

CeR14



CeR26



CeR32



CeR42



CeR46

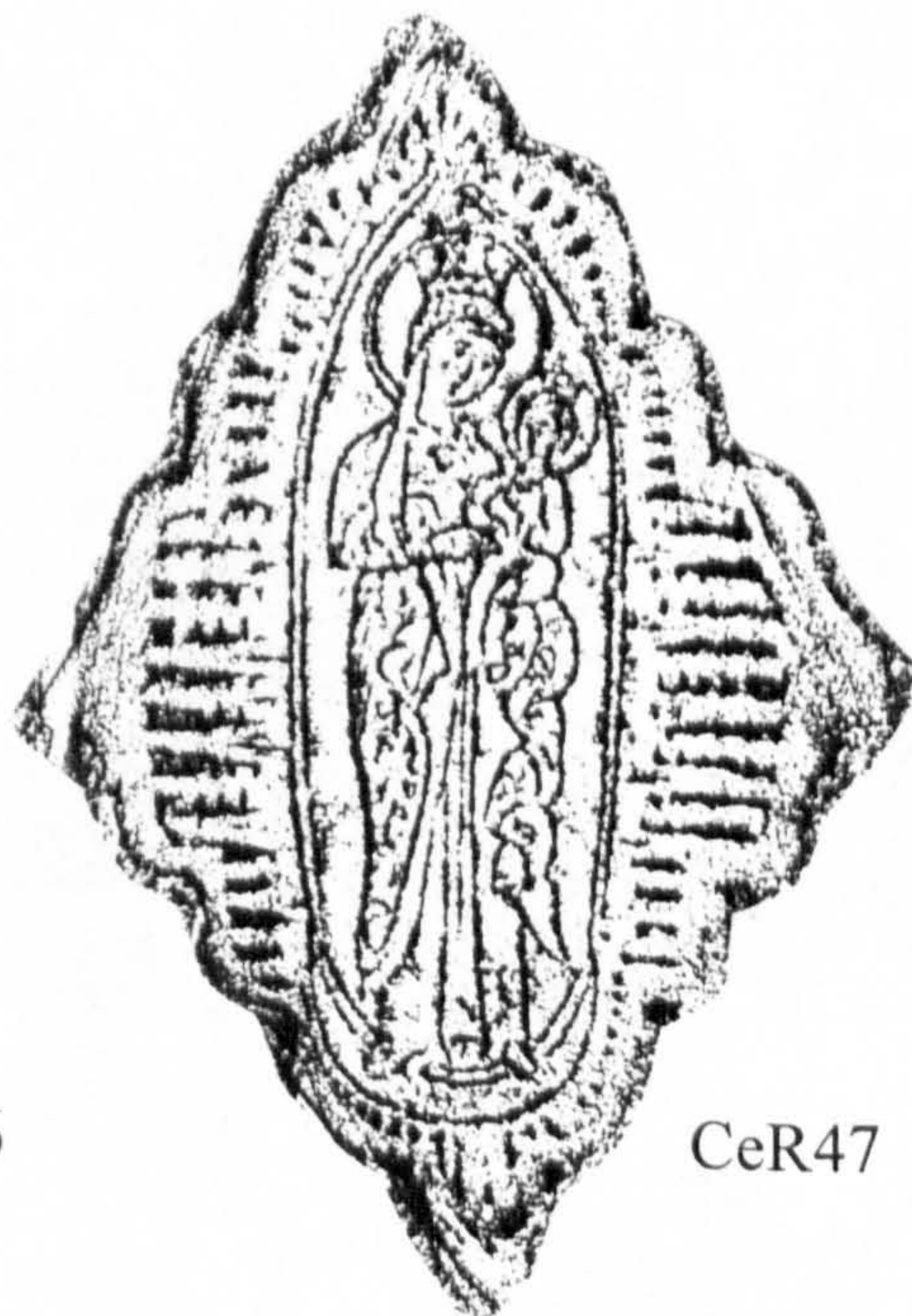

CeR47



CeR4



CeR6



CeR10



CeR24

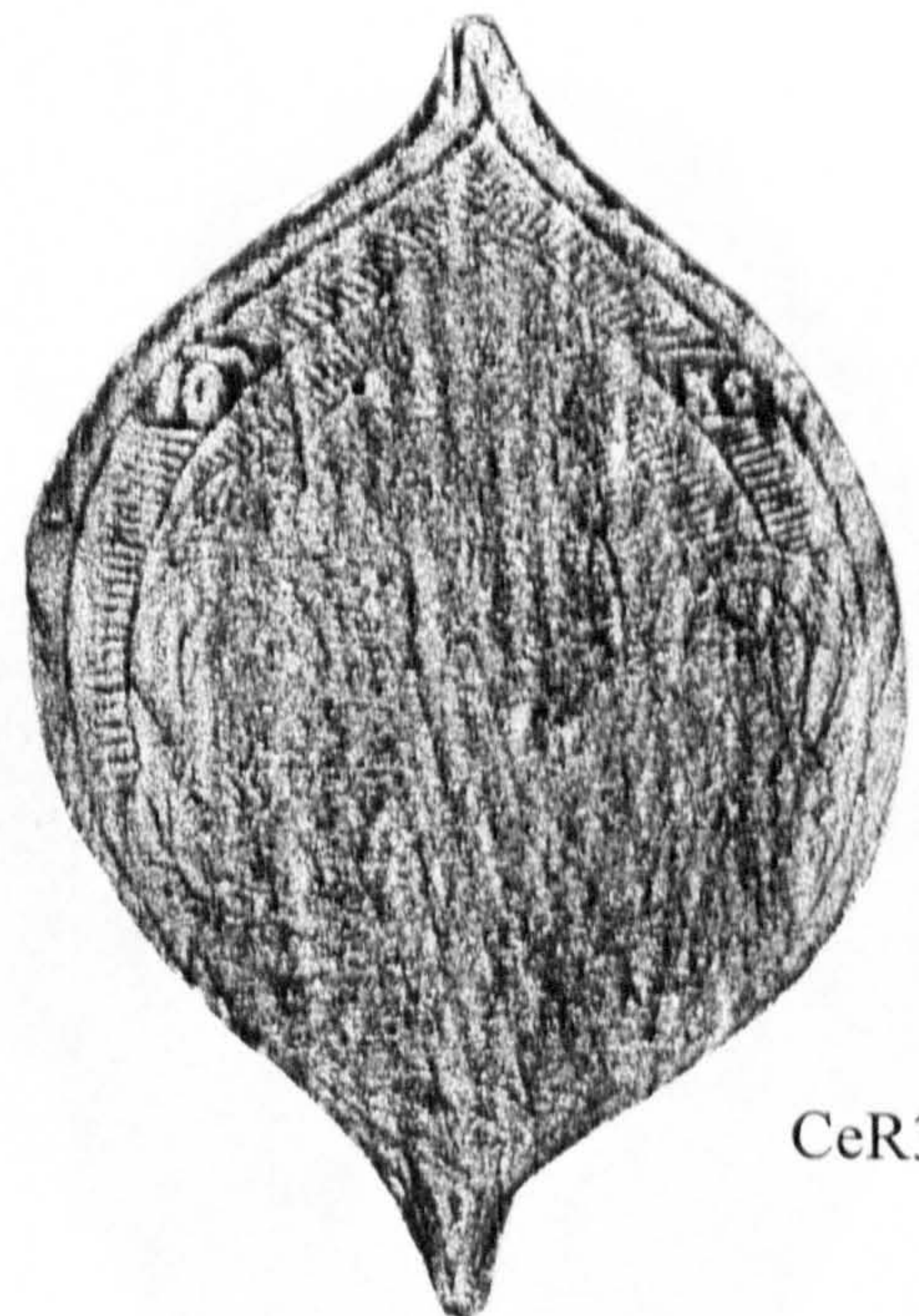

CeR31



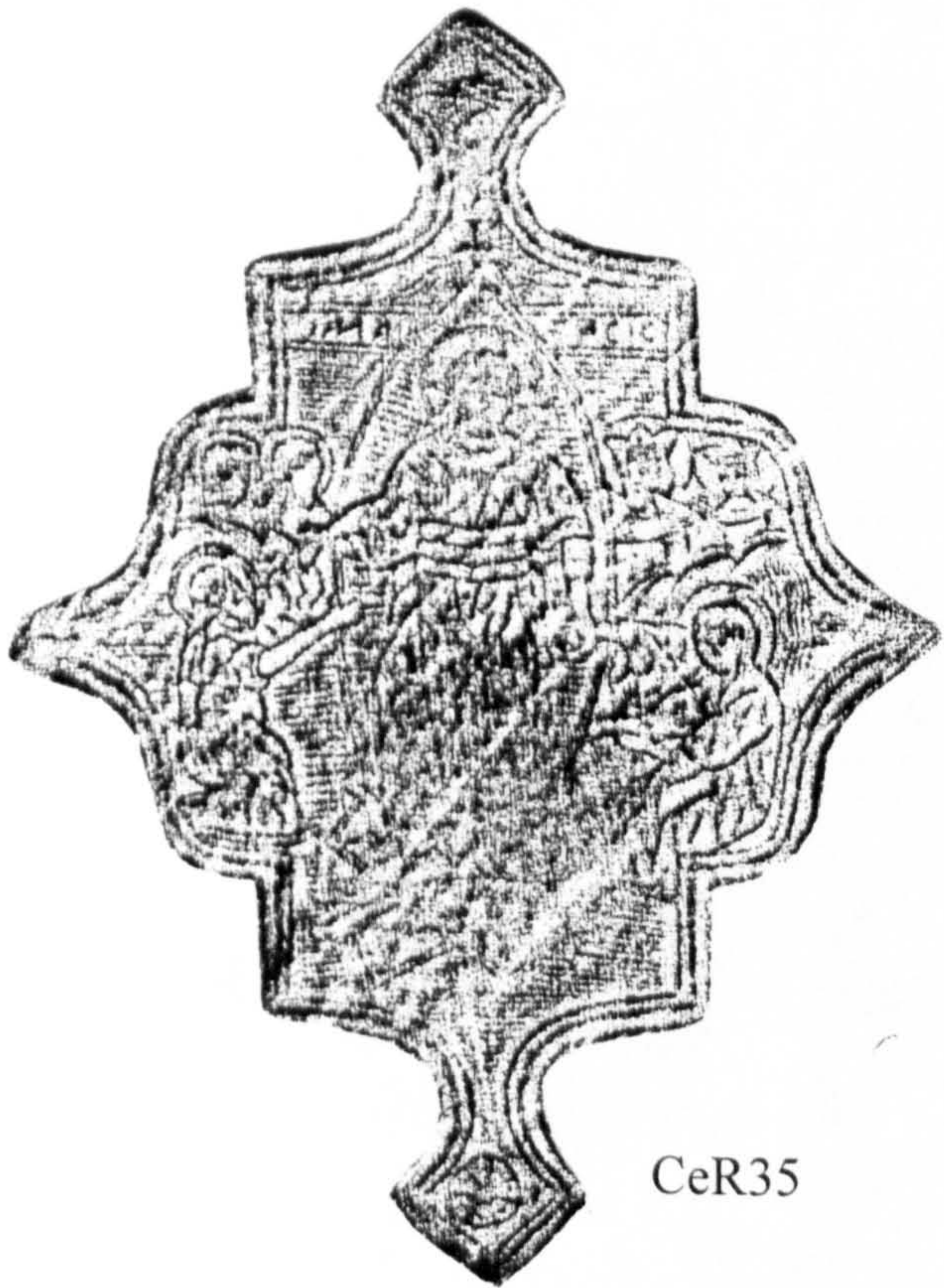

CeR35

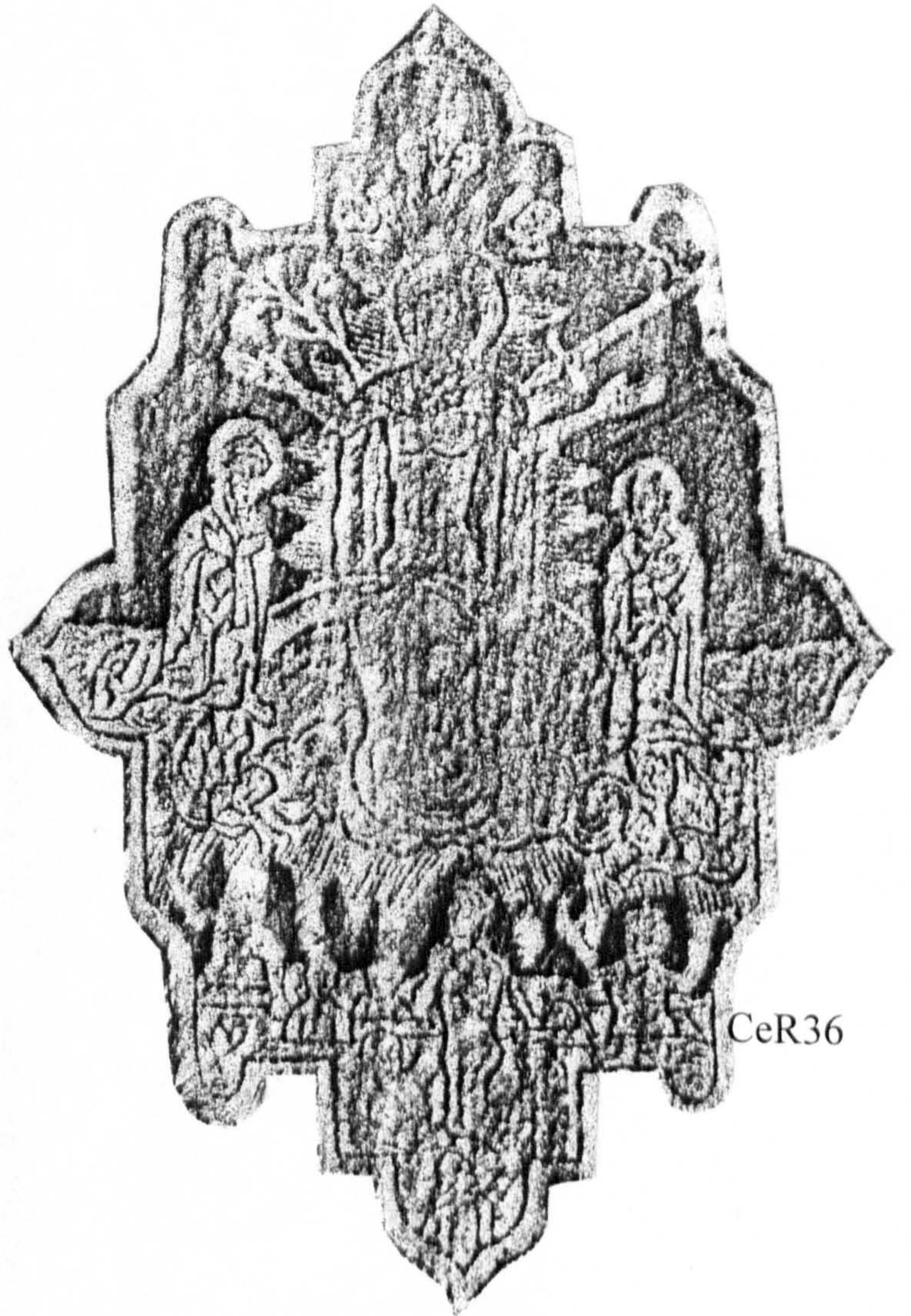

CeR36



CeR49



CeR4



CeR11



CeR17

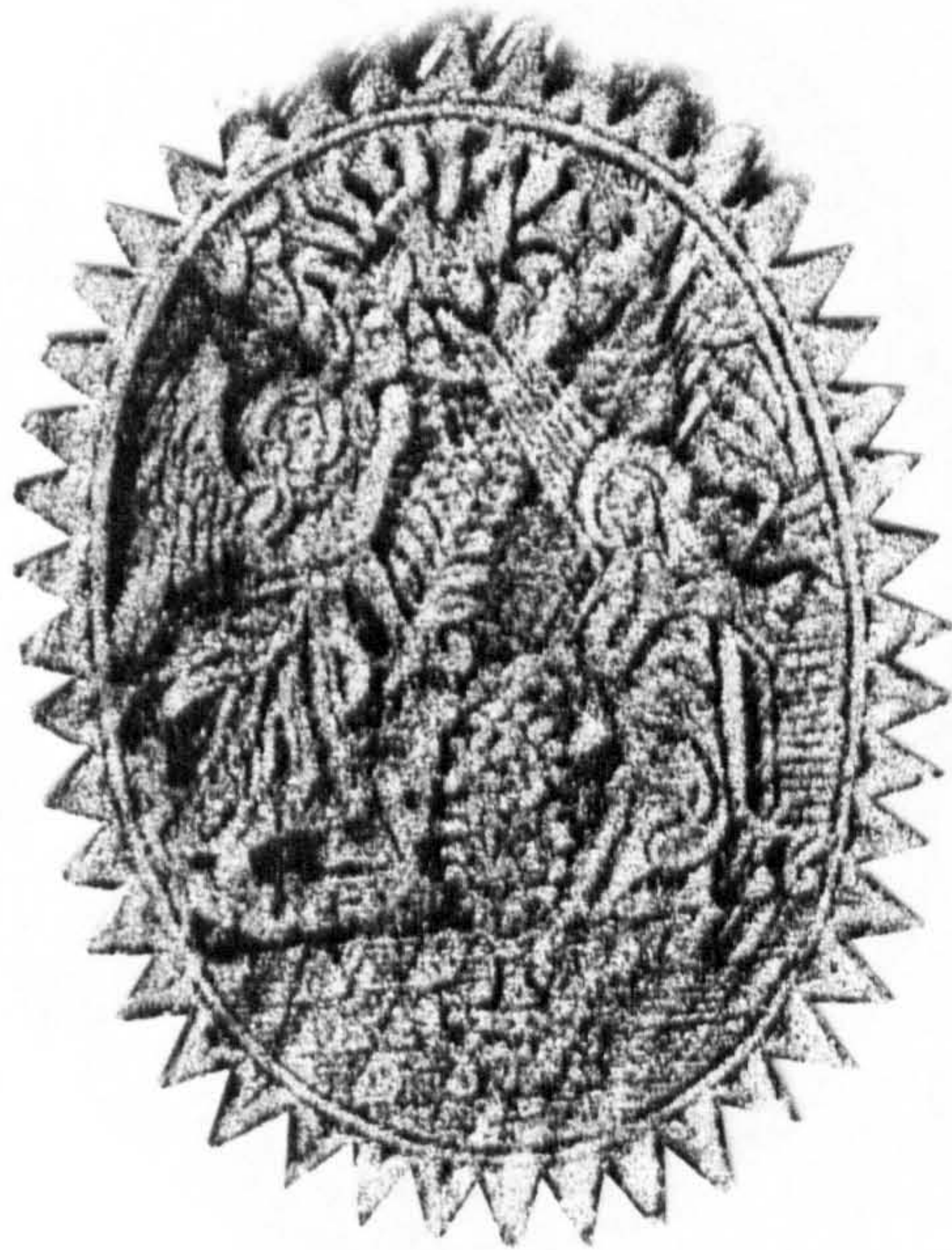

CeR25



CeR44

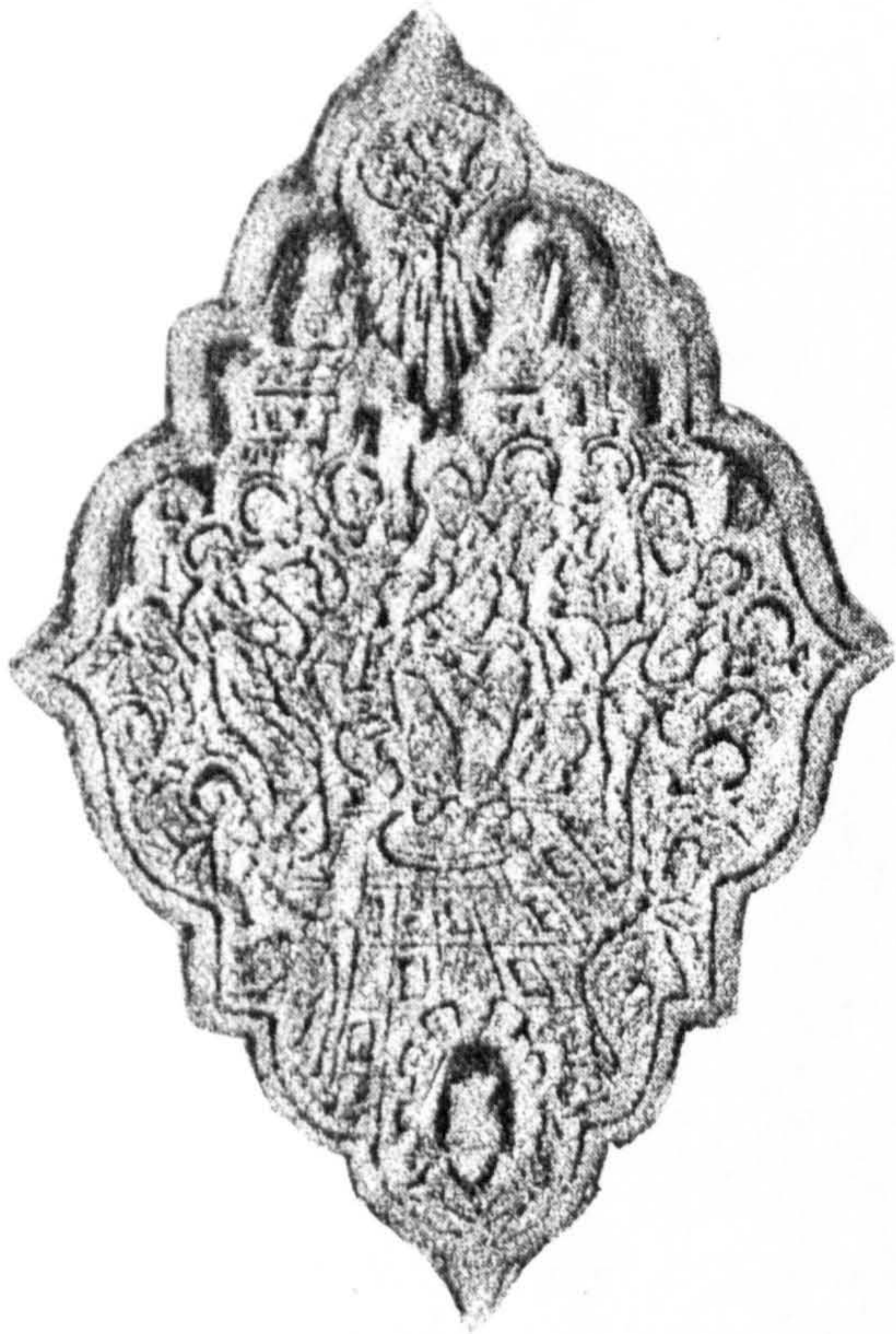

CeR7



CeR16



CeR40



CeR34



CeR15

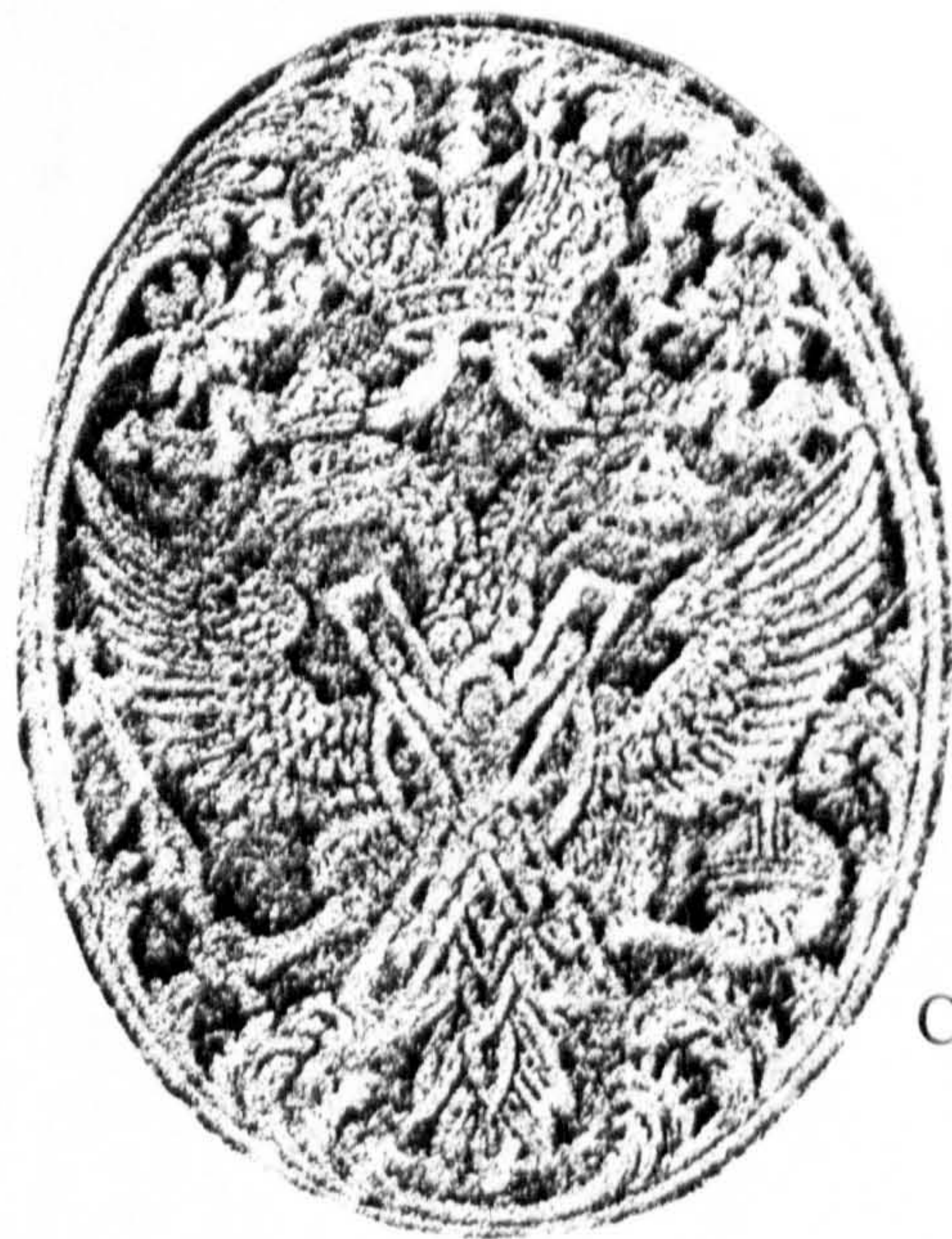

CeR27

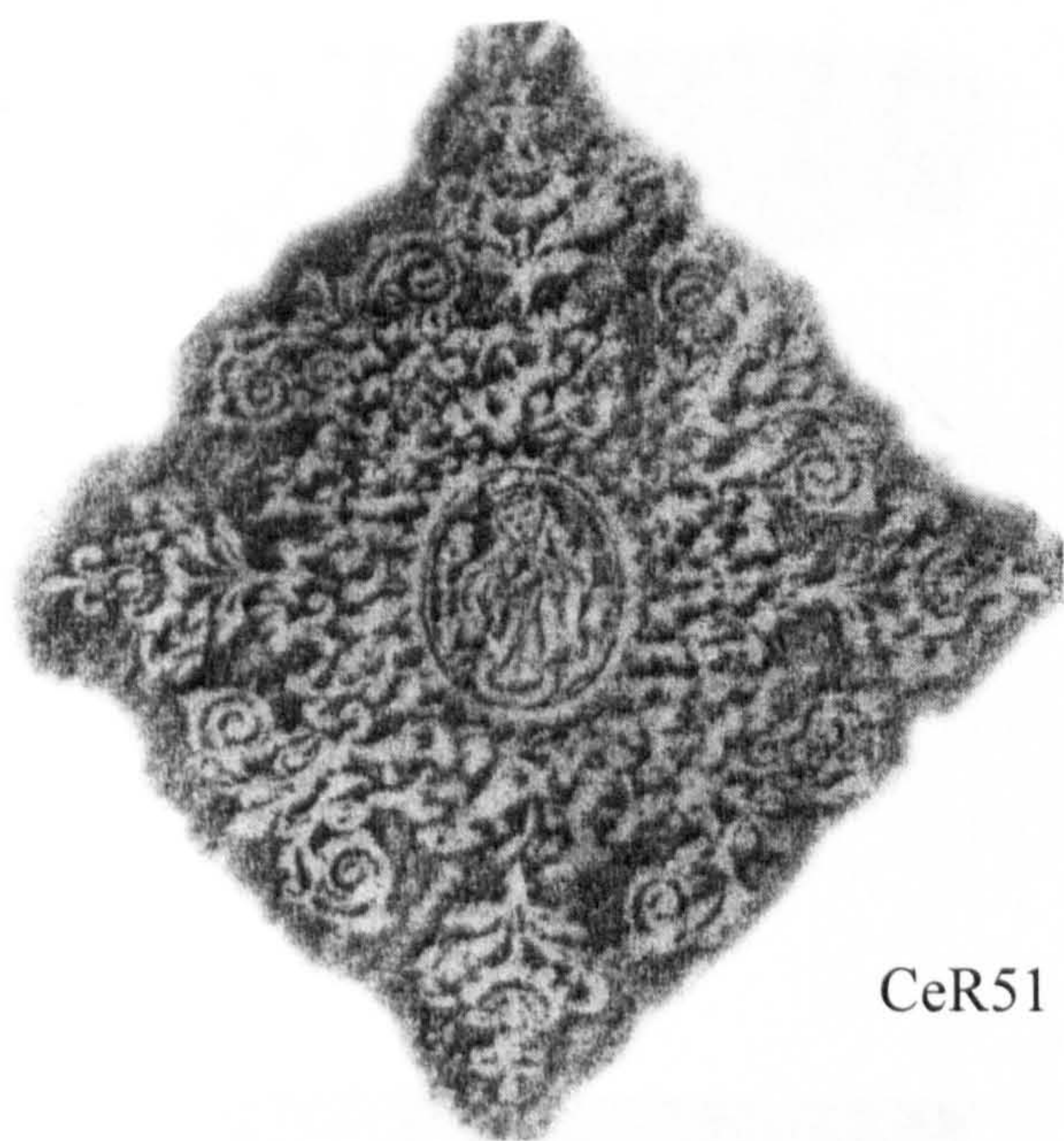

CeR51



CeR1



CeR30



CeR29

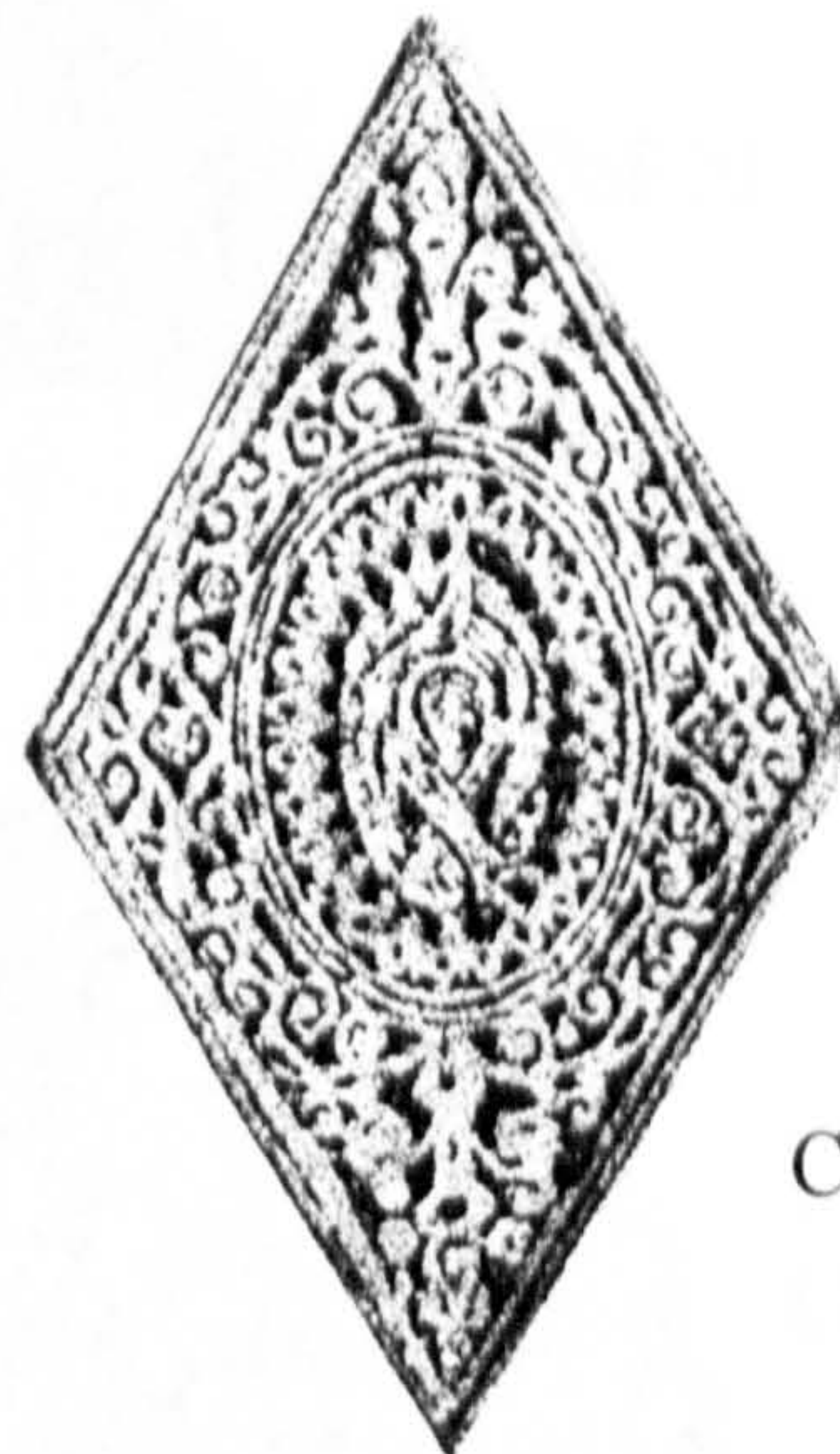

CeR28

COF

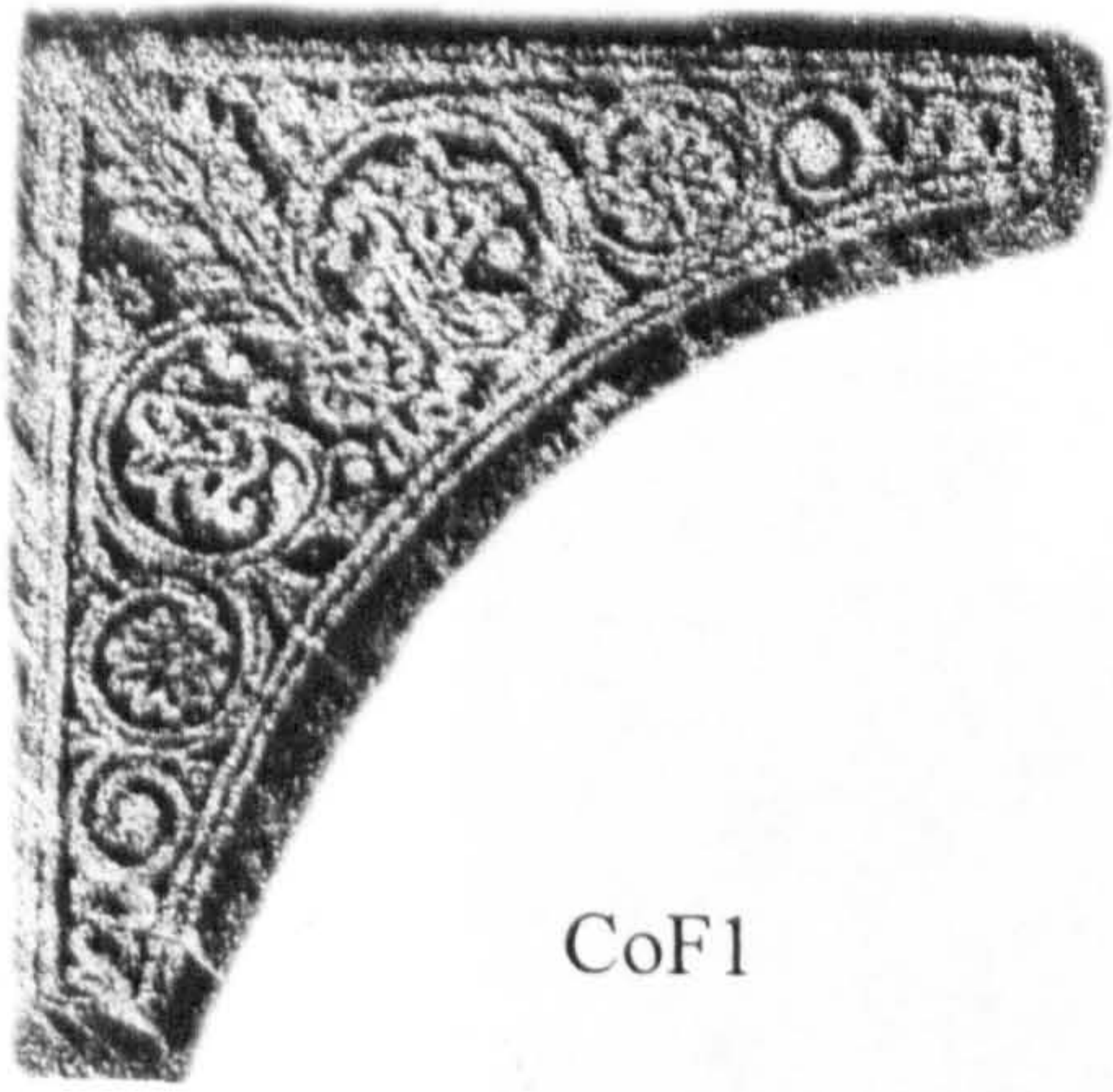

CoF1

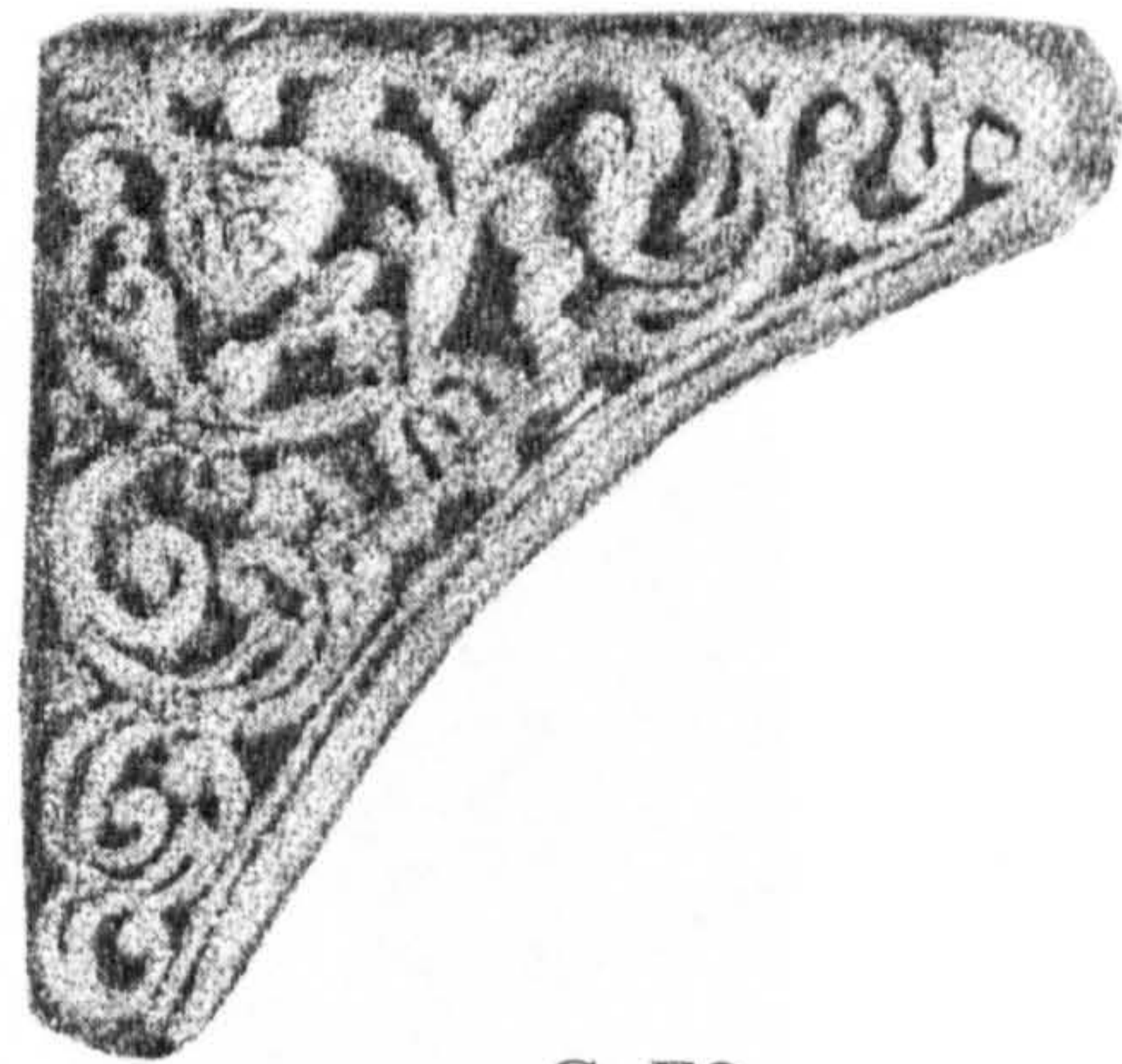

CoF2

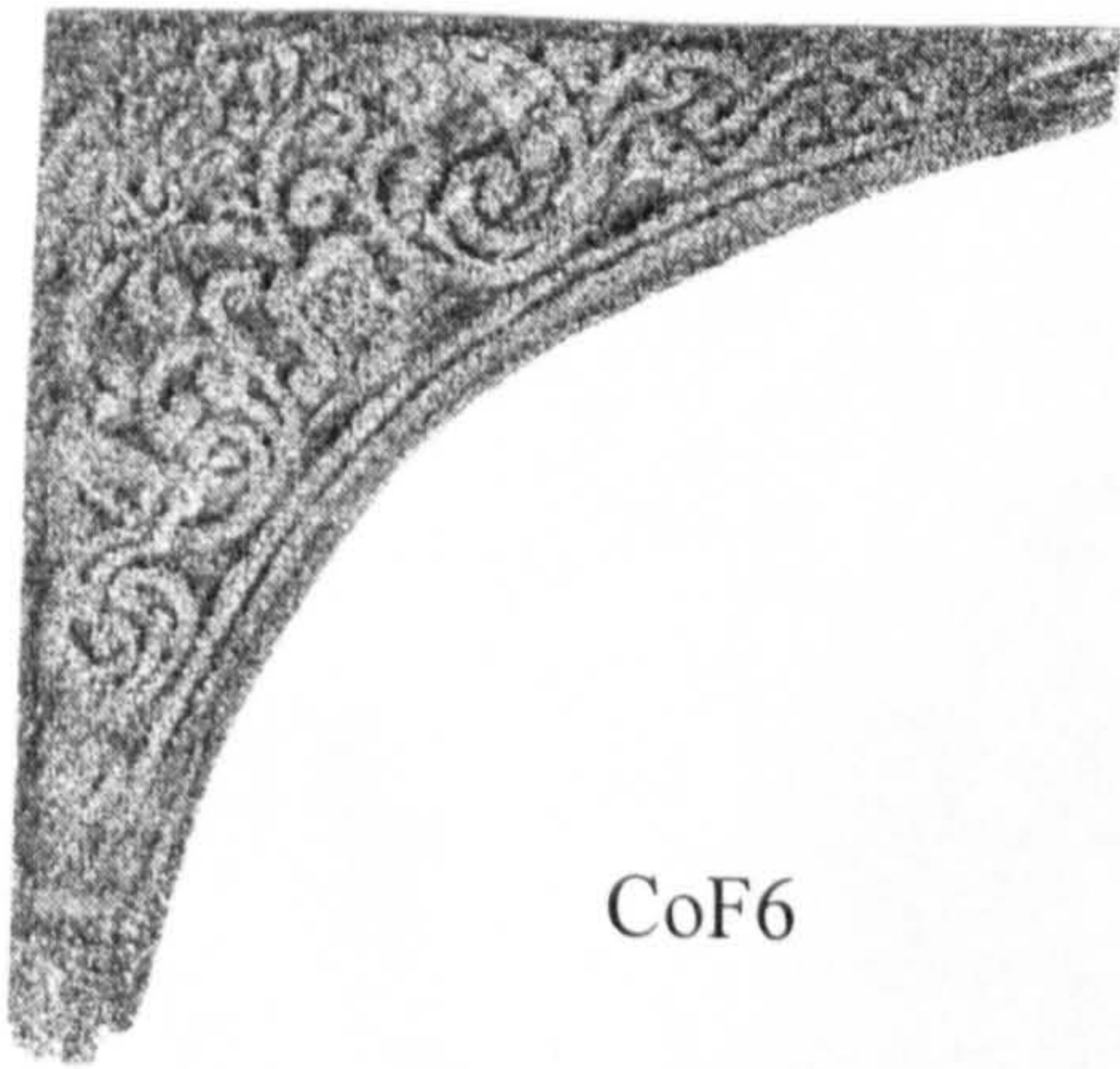

CoF6

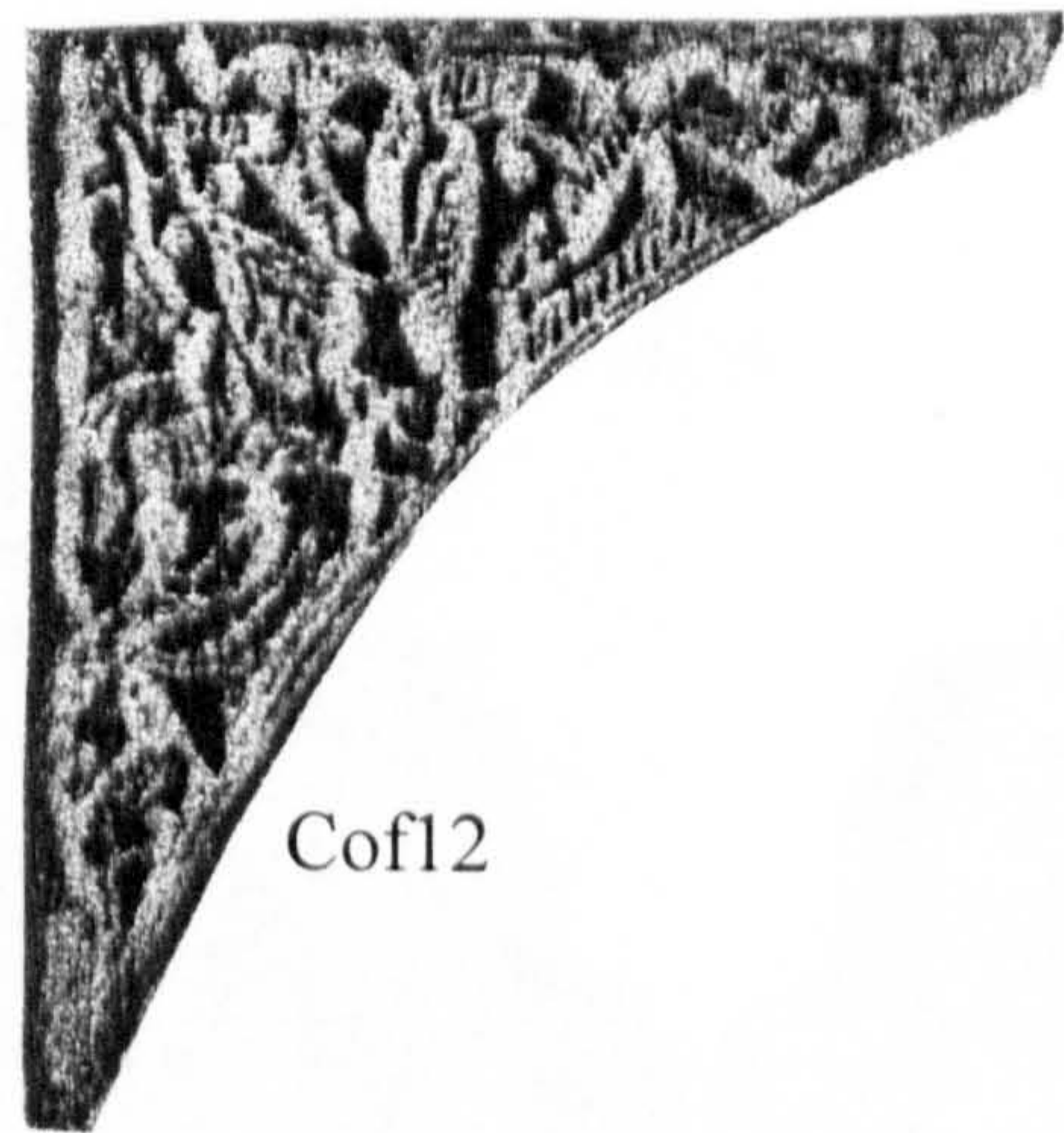

Cof12

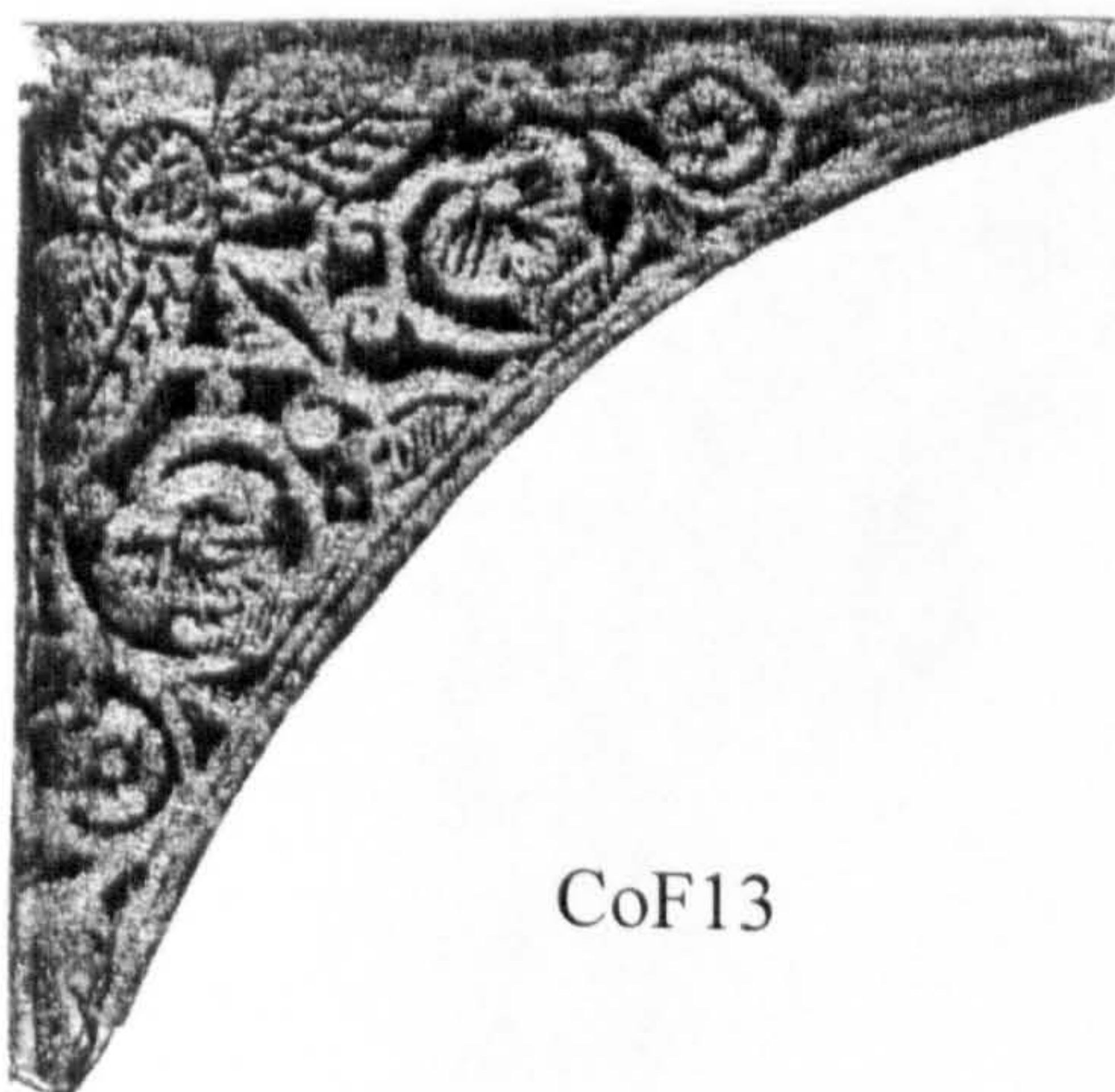

CoF13



CoF20

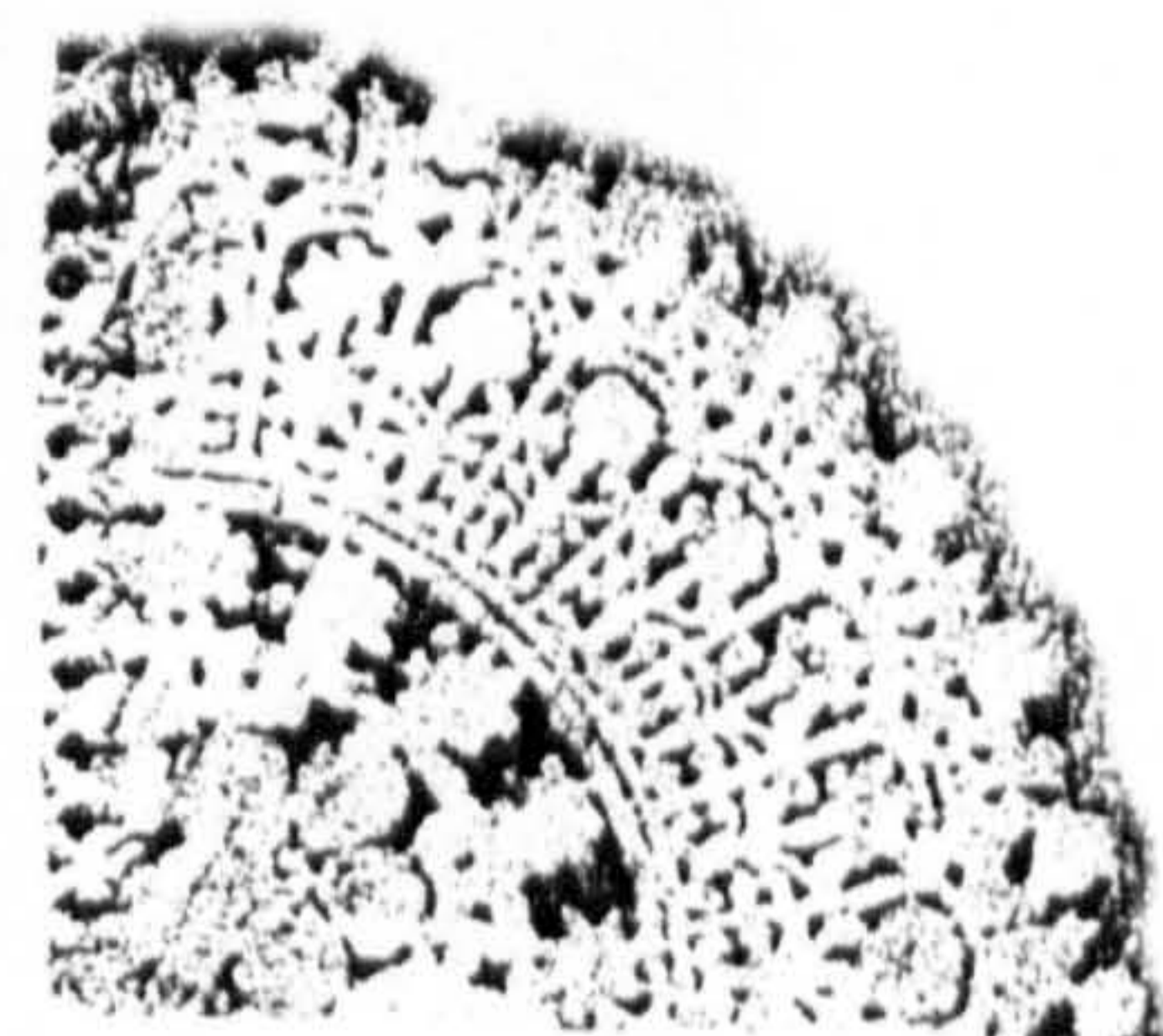

CoF17



CoF3



CoF4



CoF14



CoF21



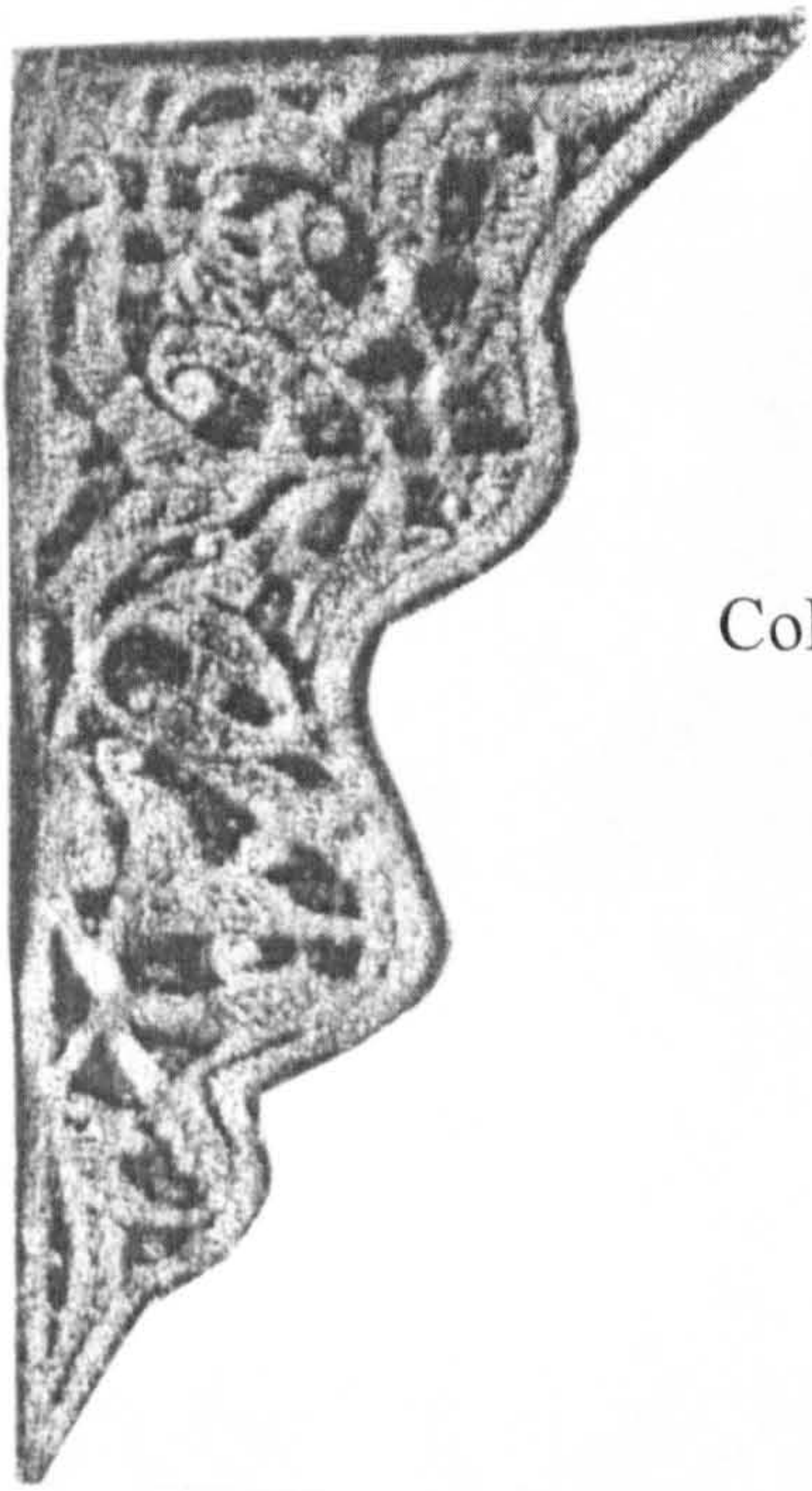

CoF11

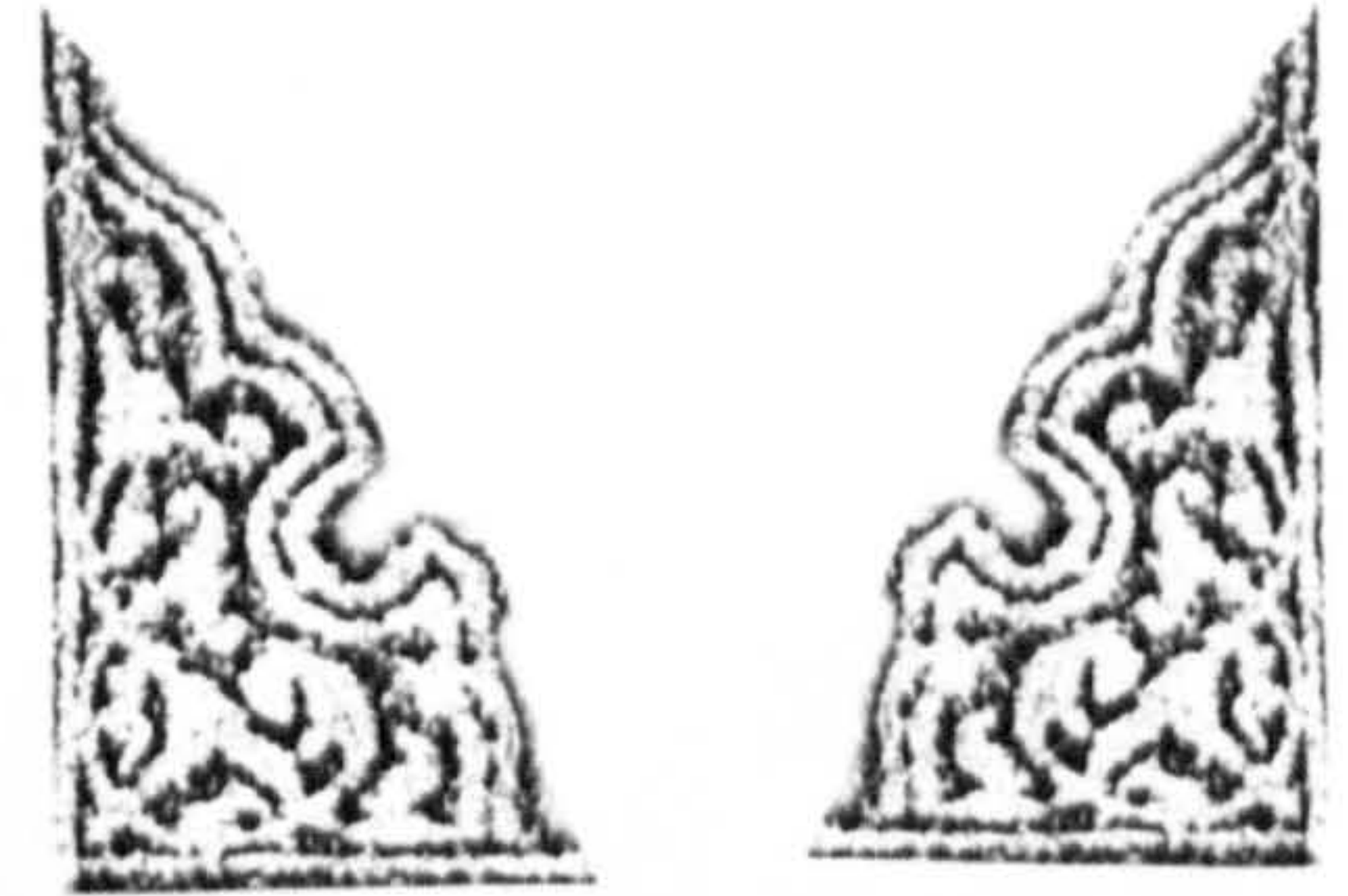

CoF18

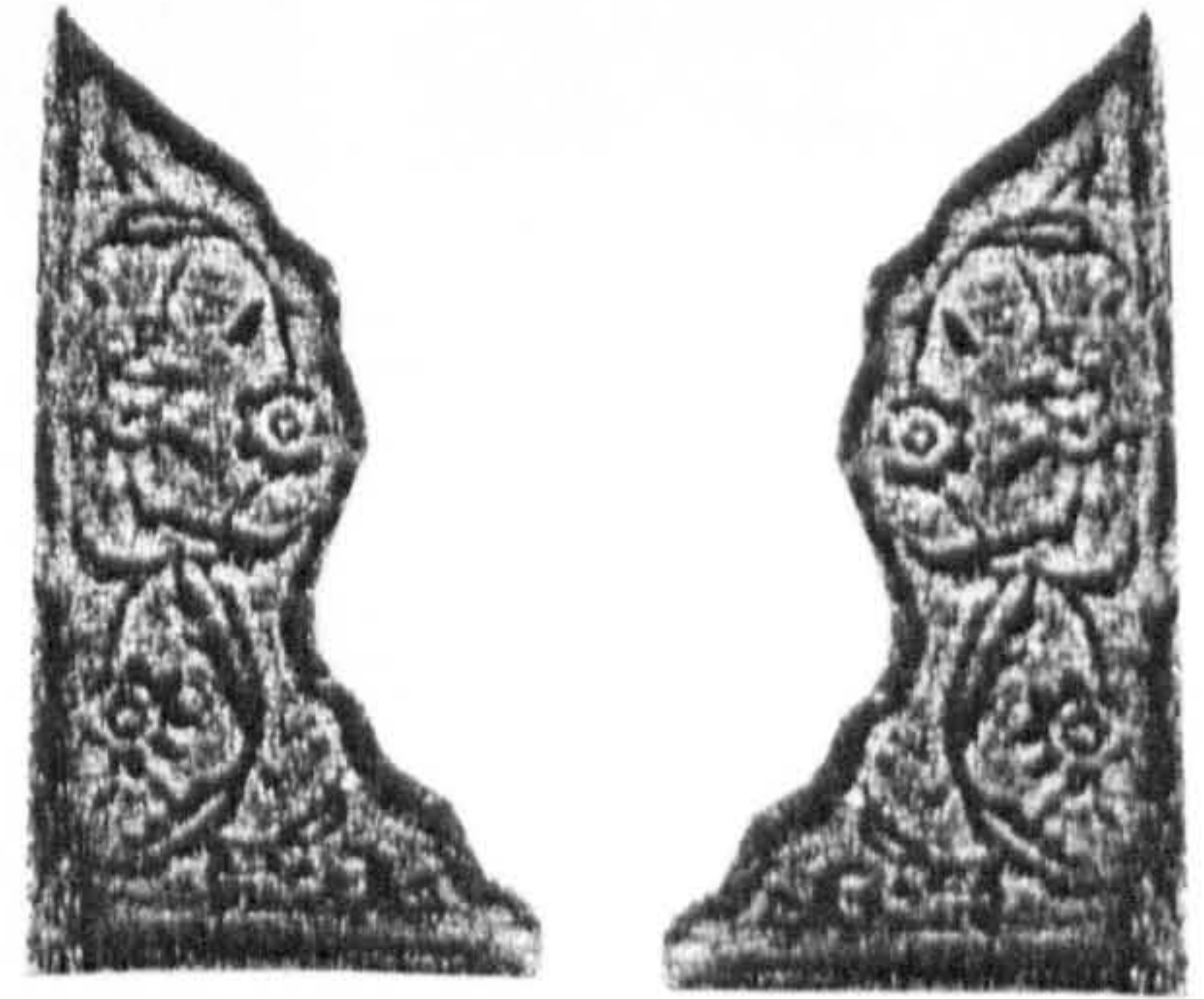

CoF9



CoF10

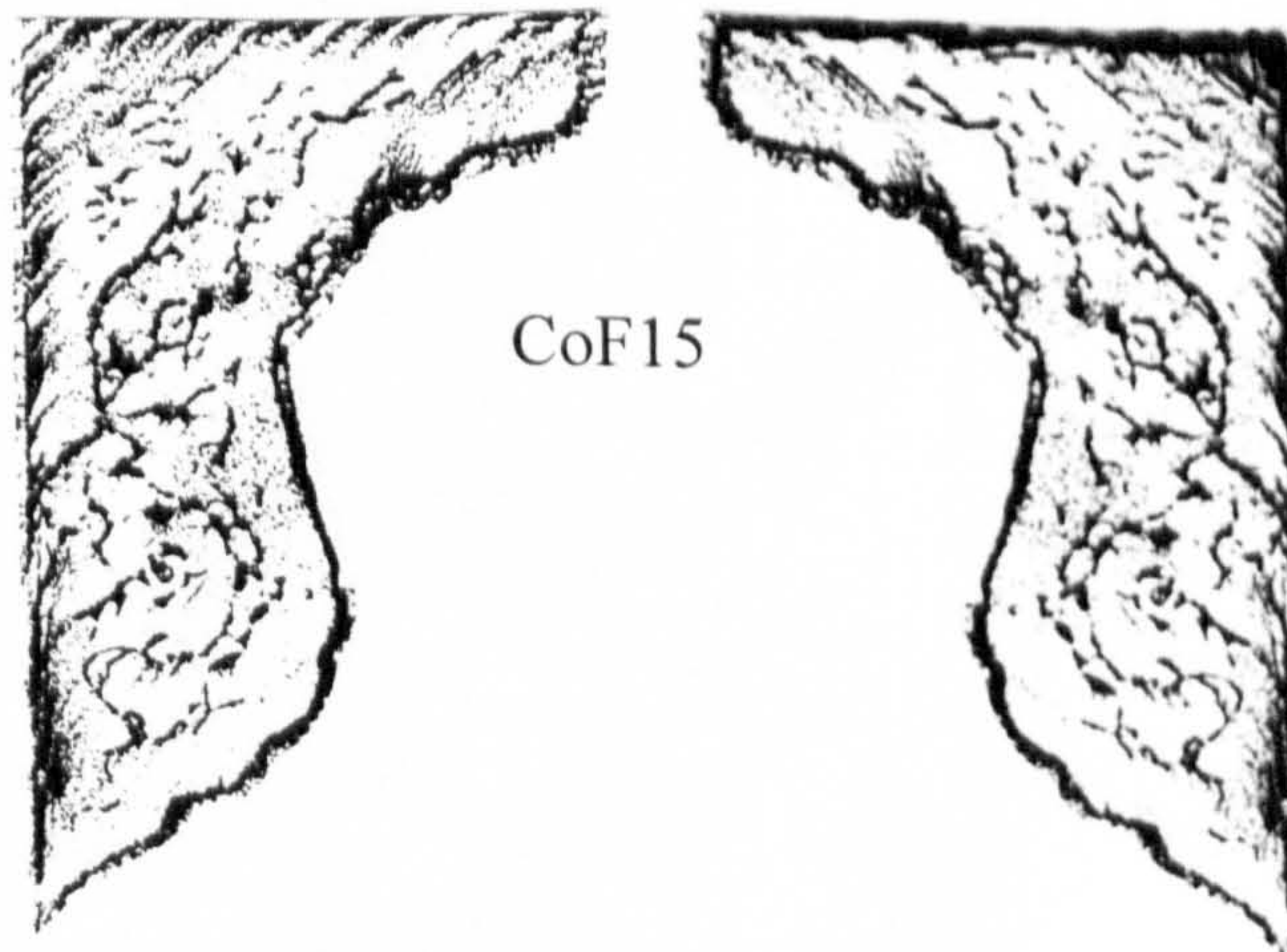
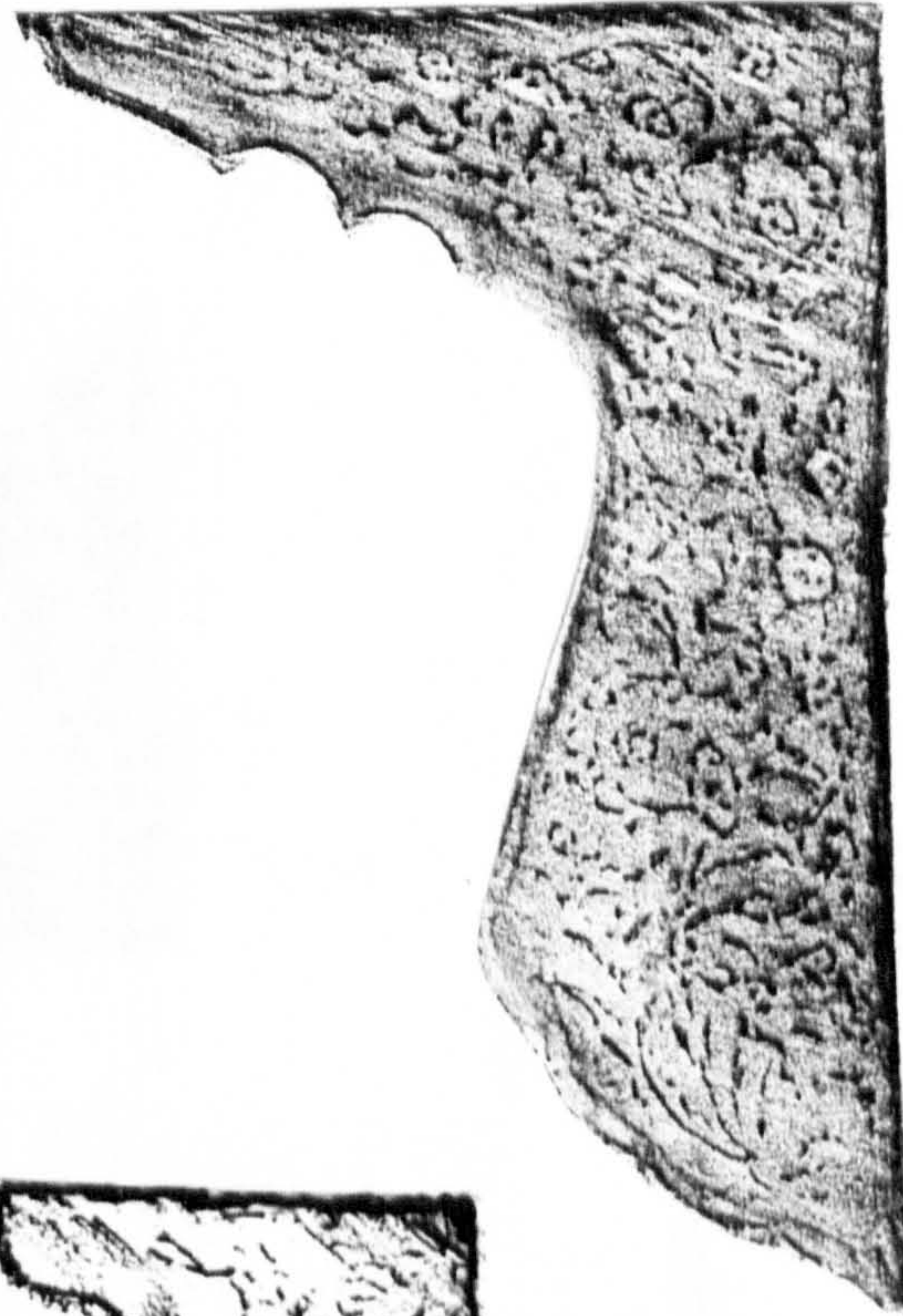

CoF15

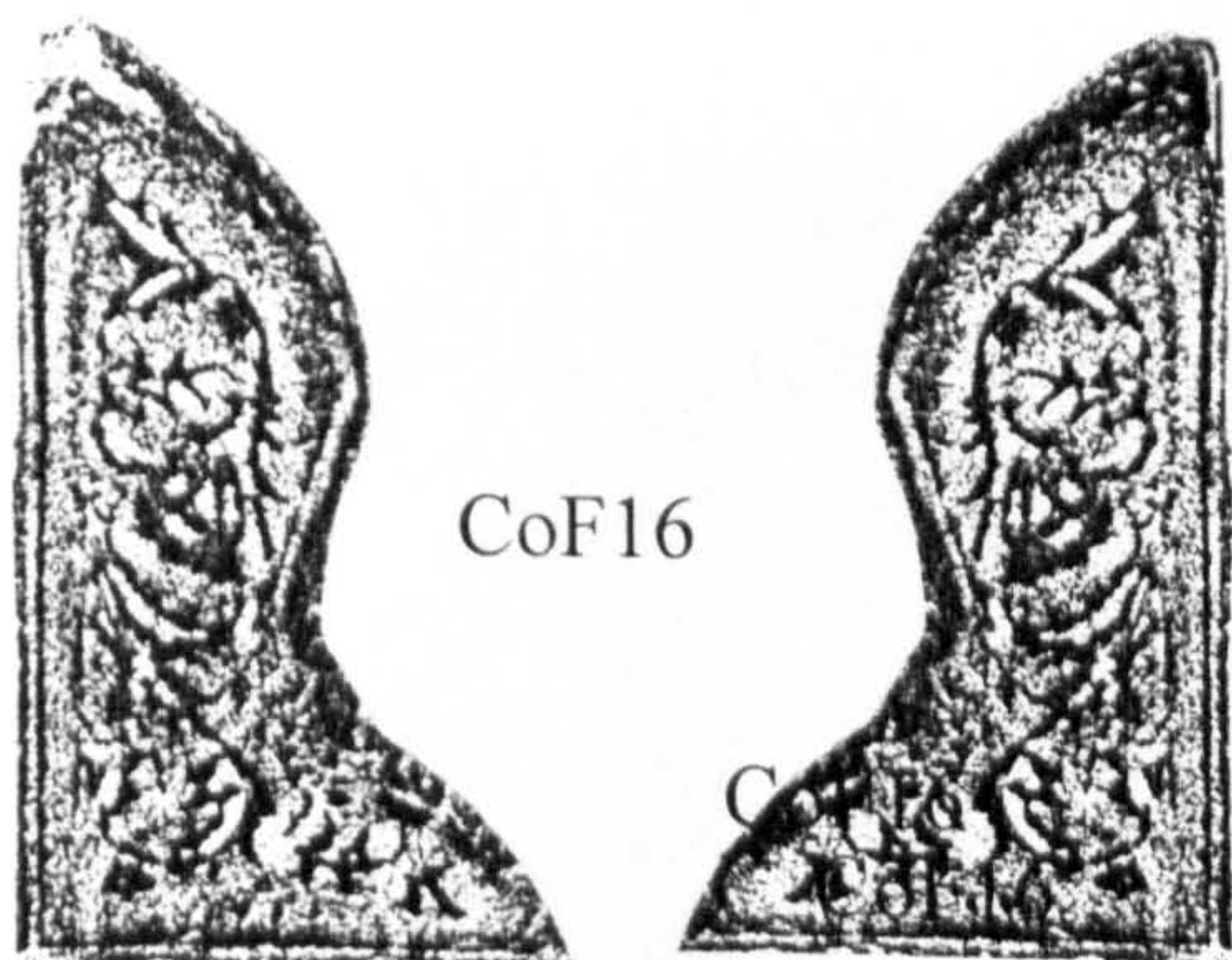

CoF16

CoF16

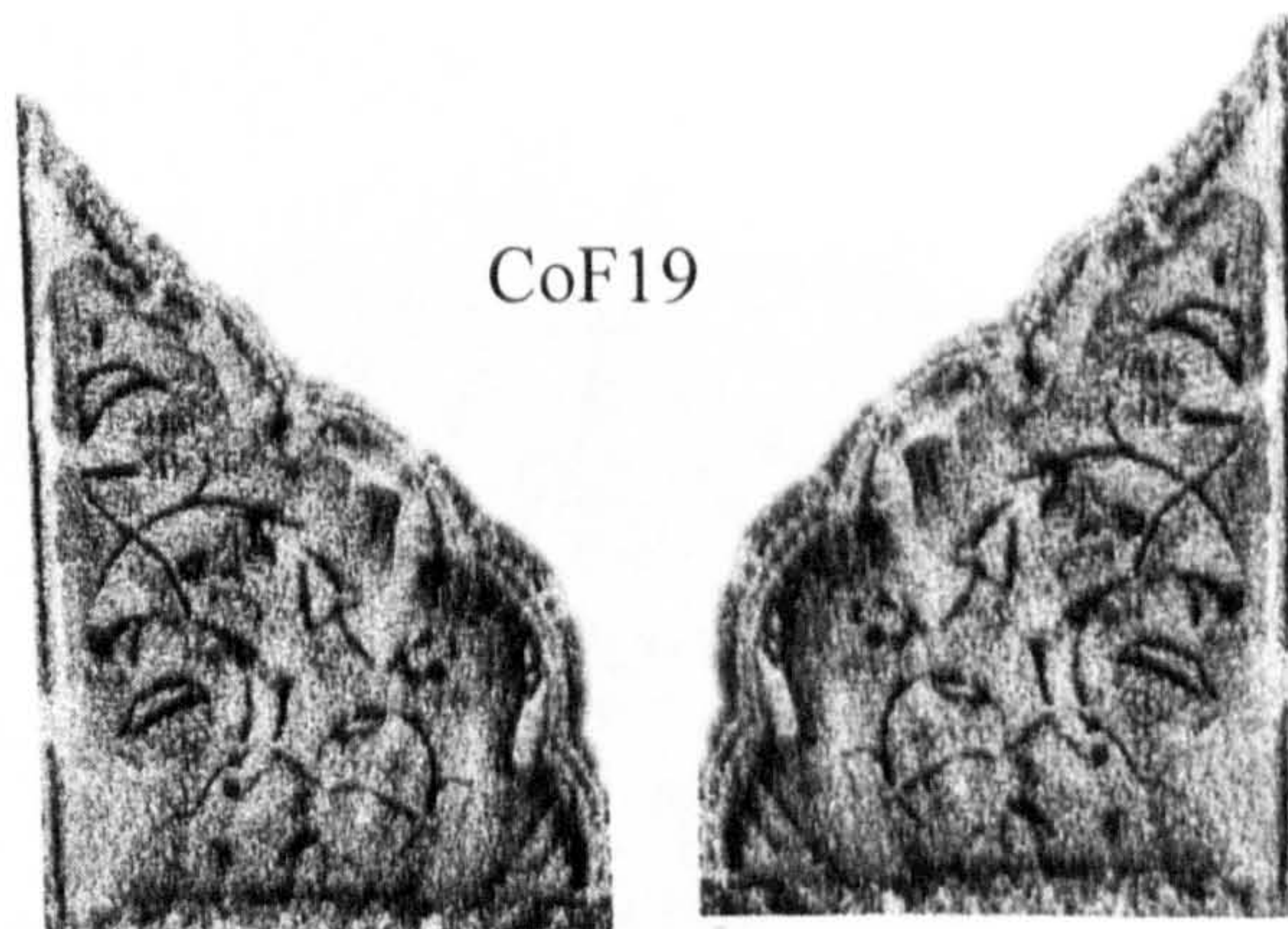

CoF19

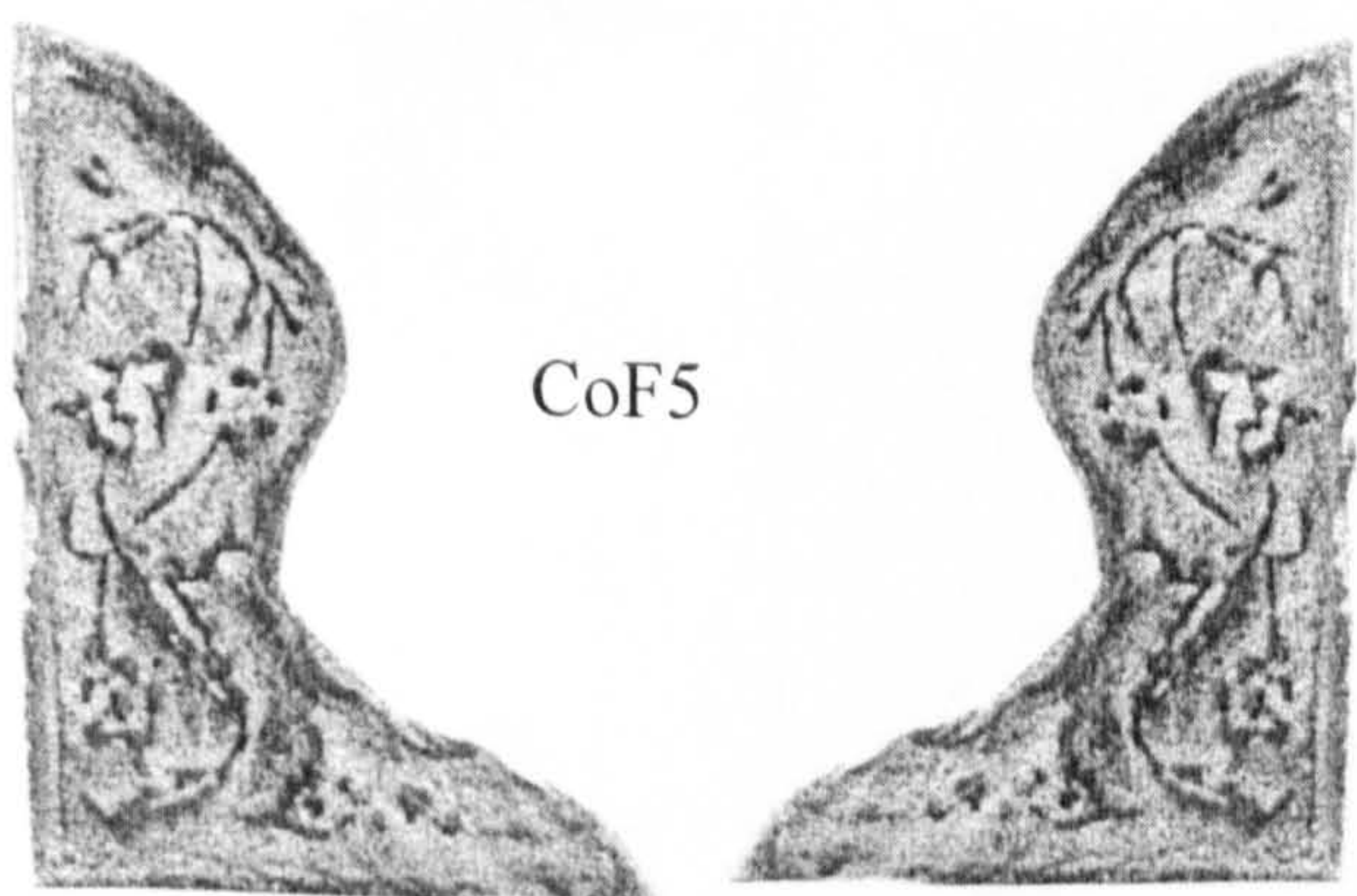

CoF5

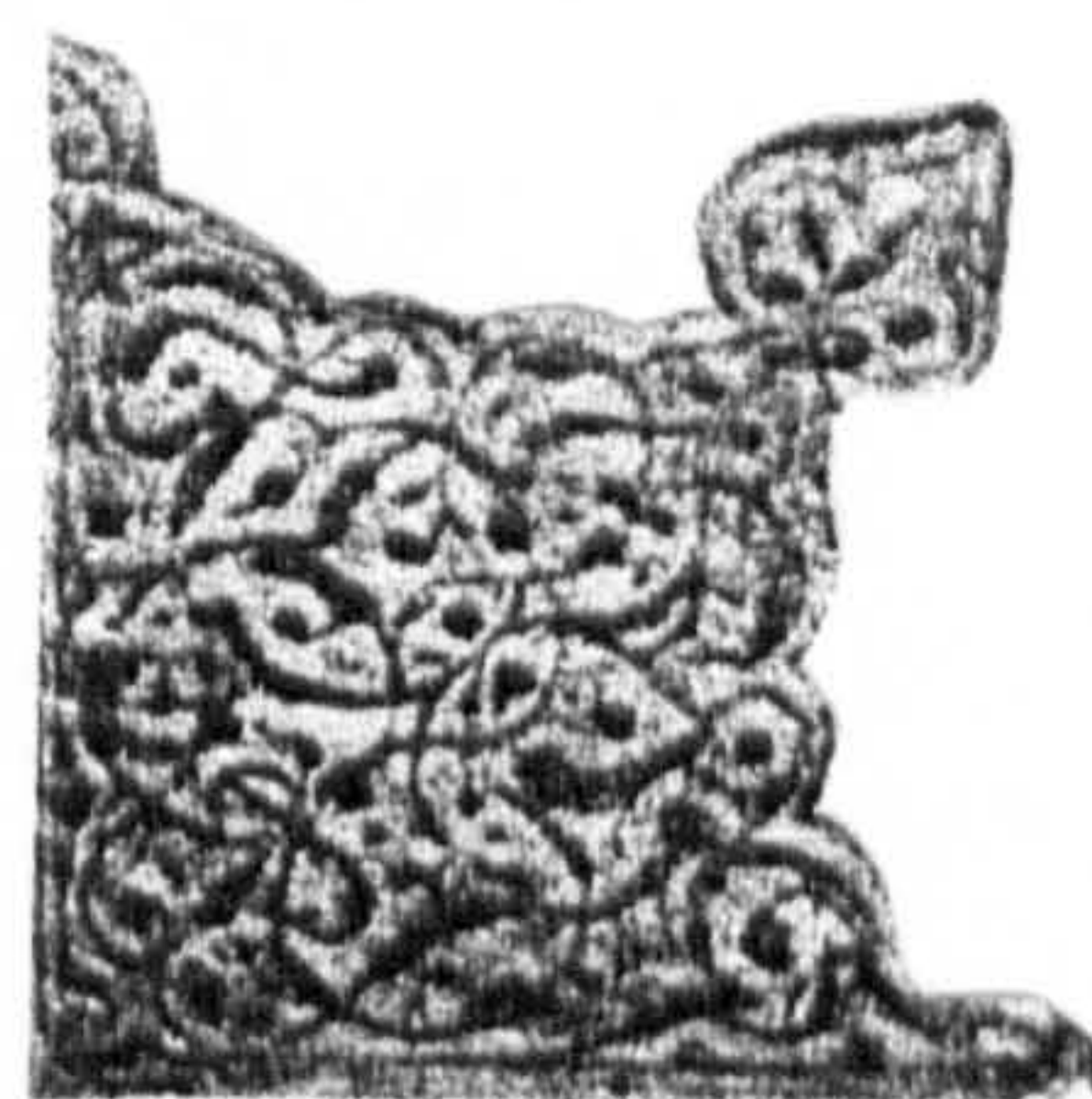

CoF8

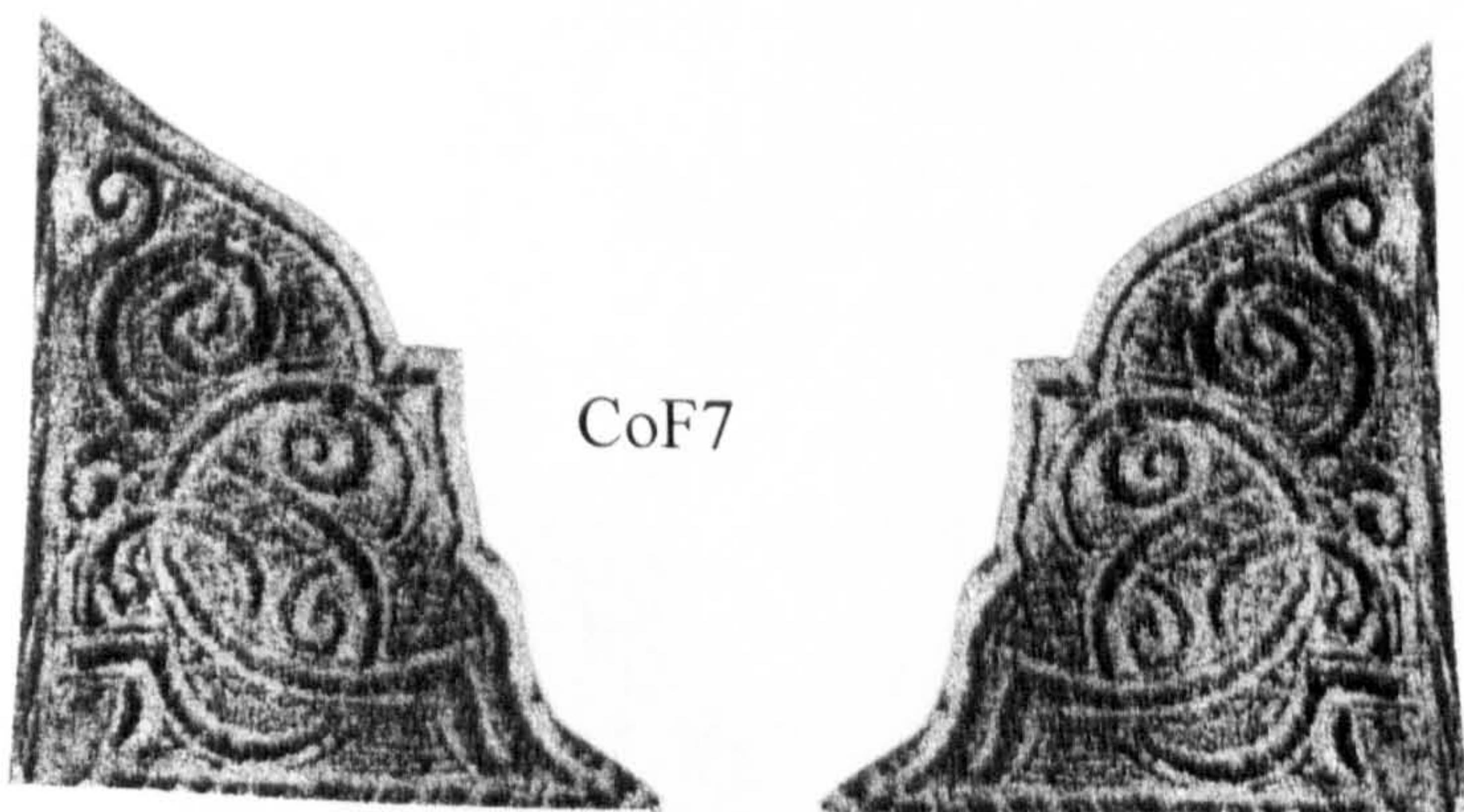

CoF7



CoF22



CoF23



COR



CoR1



CoR2



CoR3

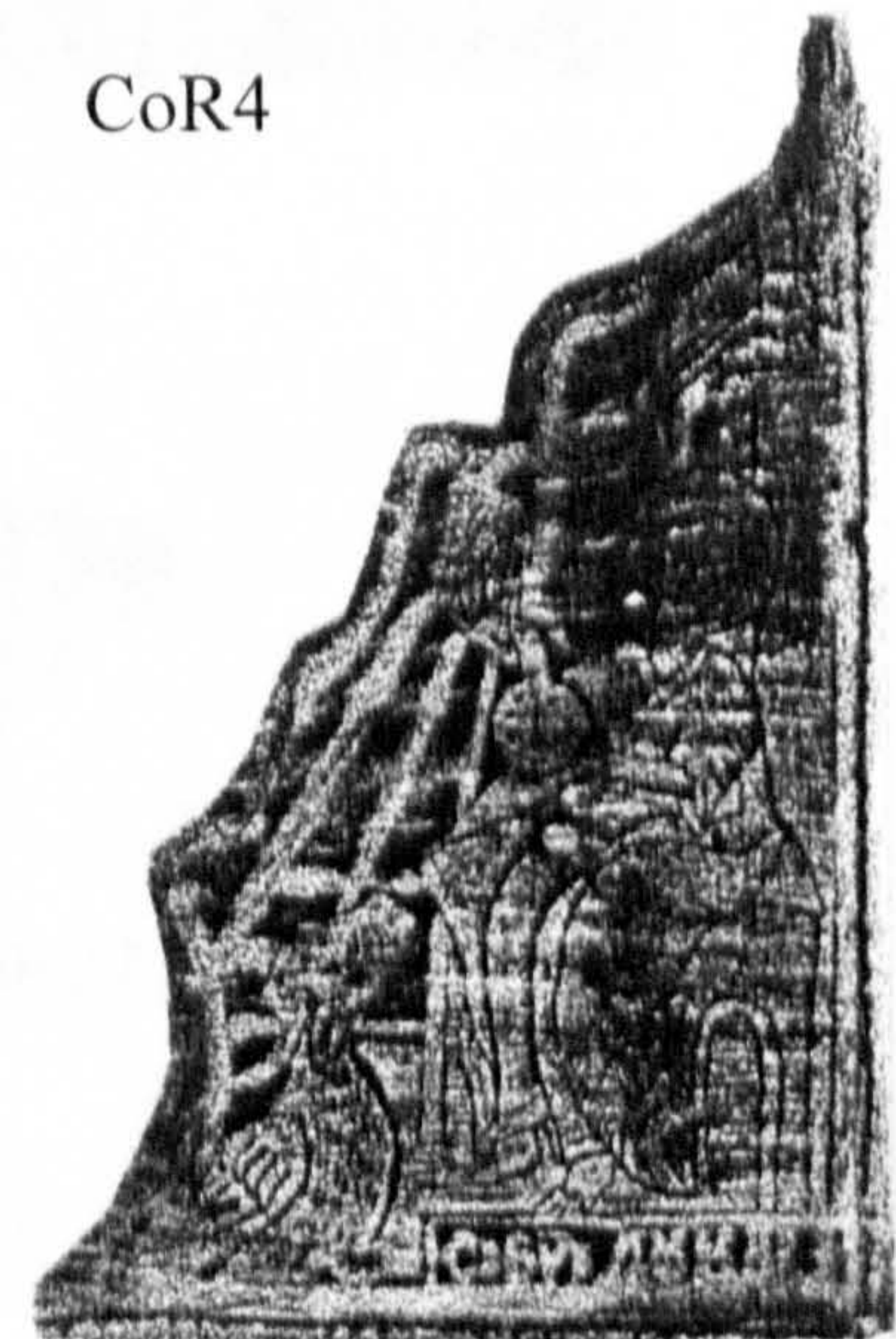

CoR4

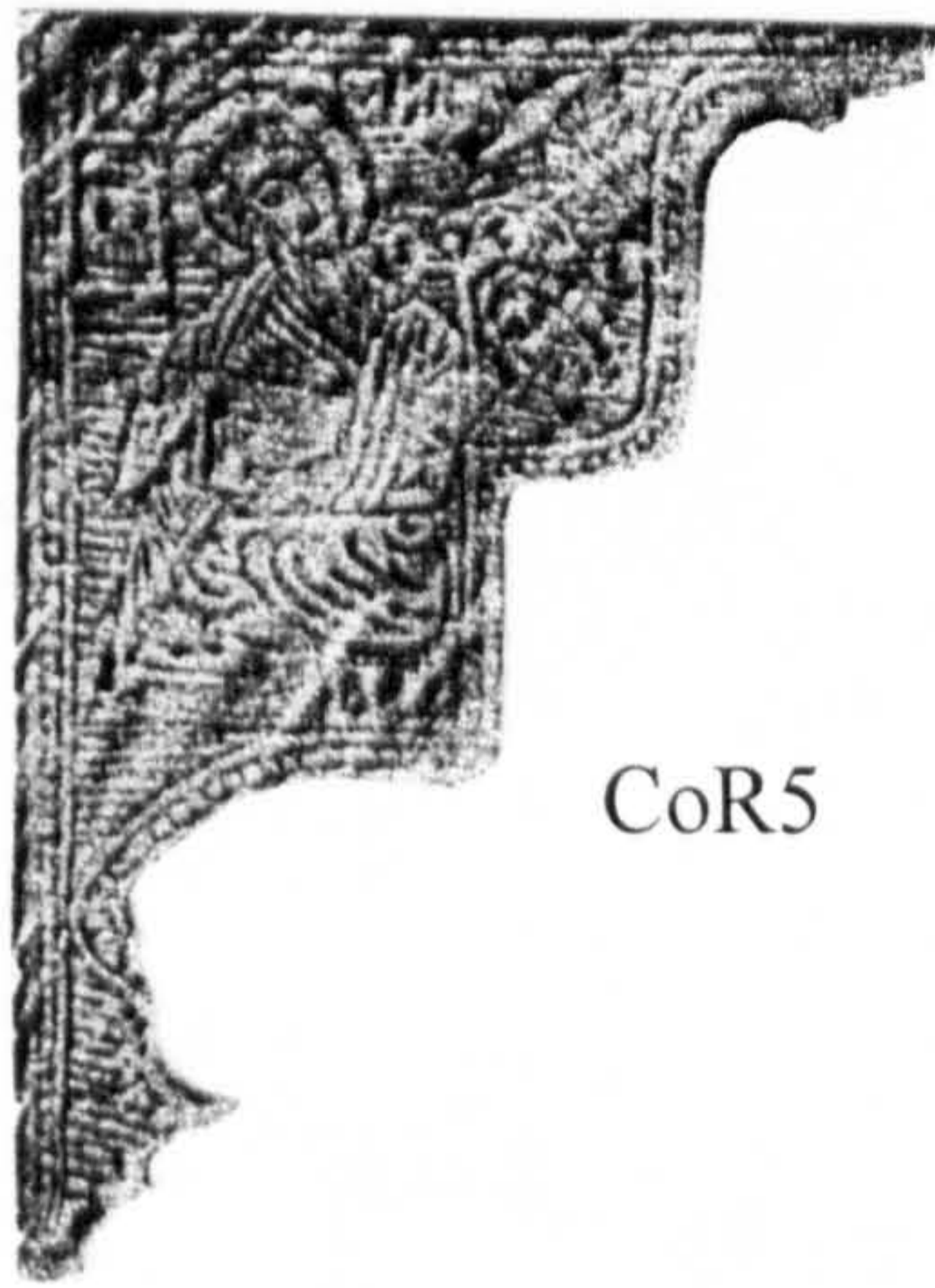

CoR5

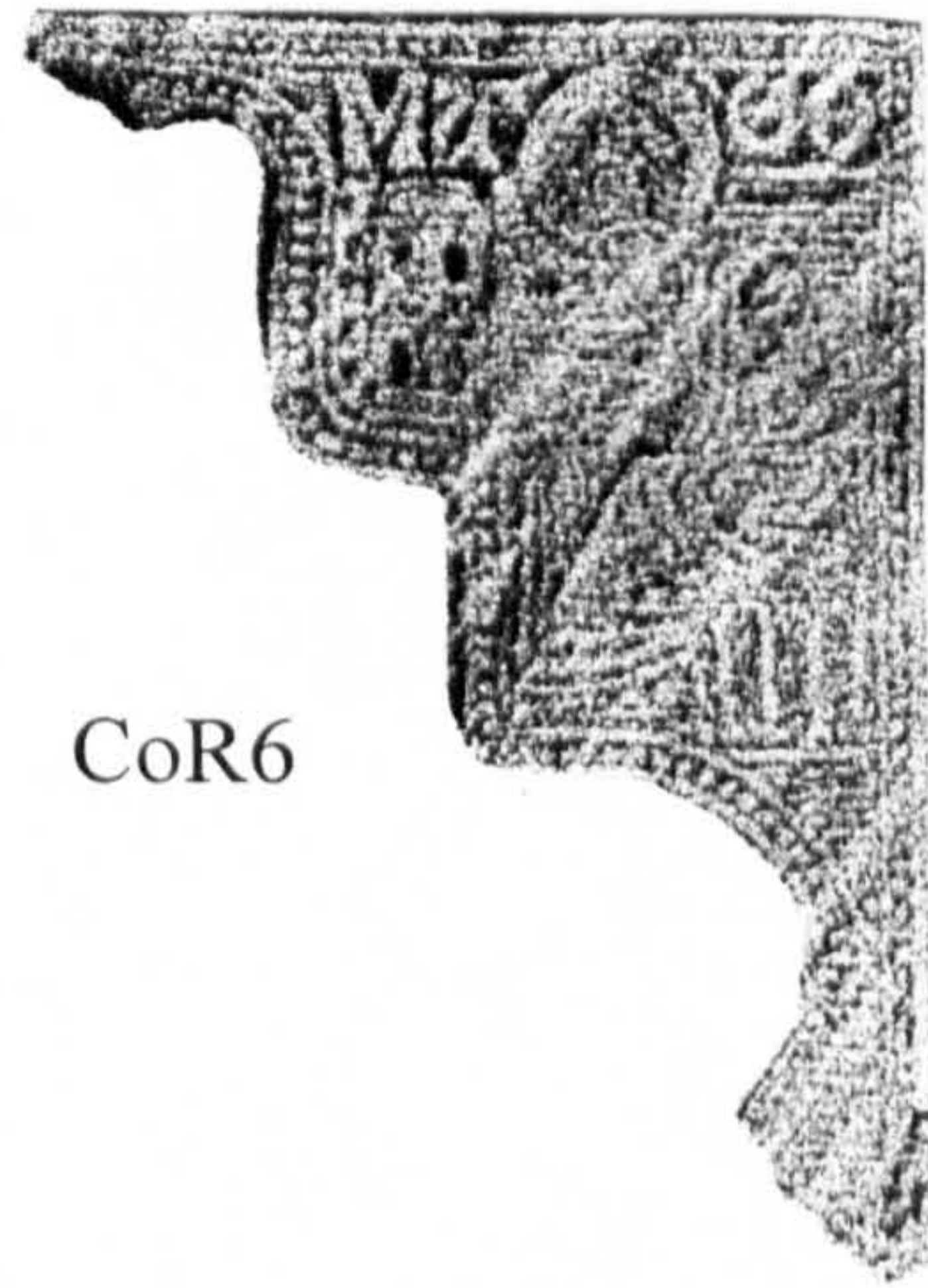

CoR6

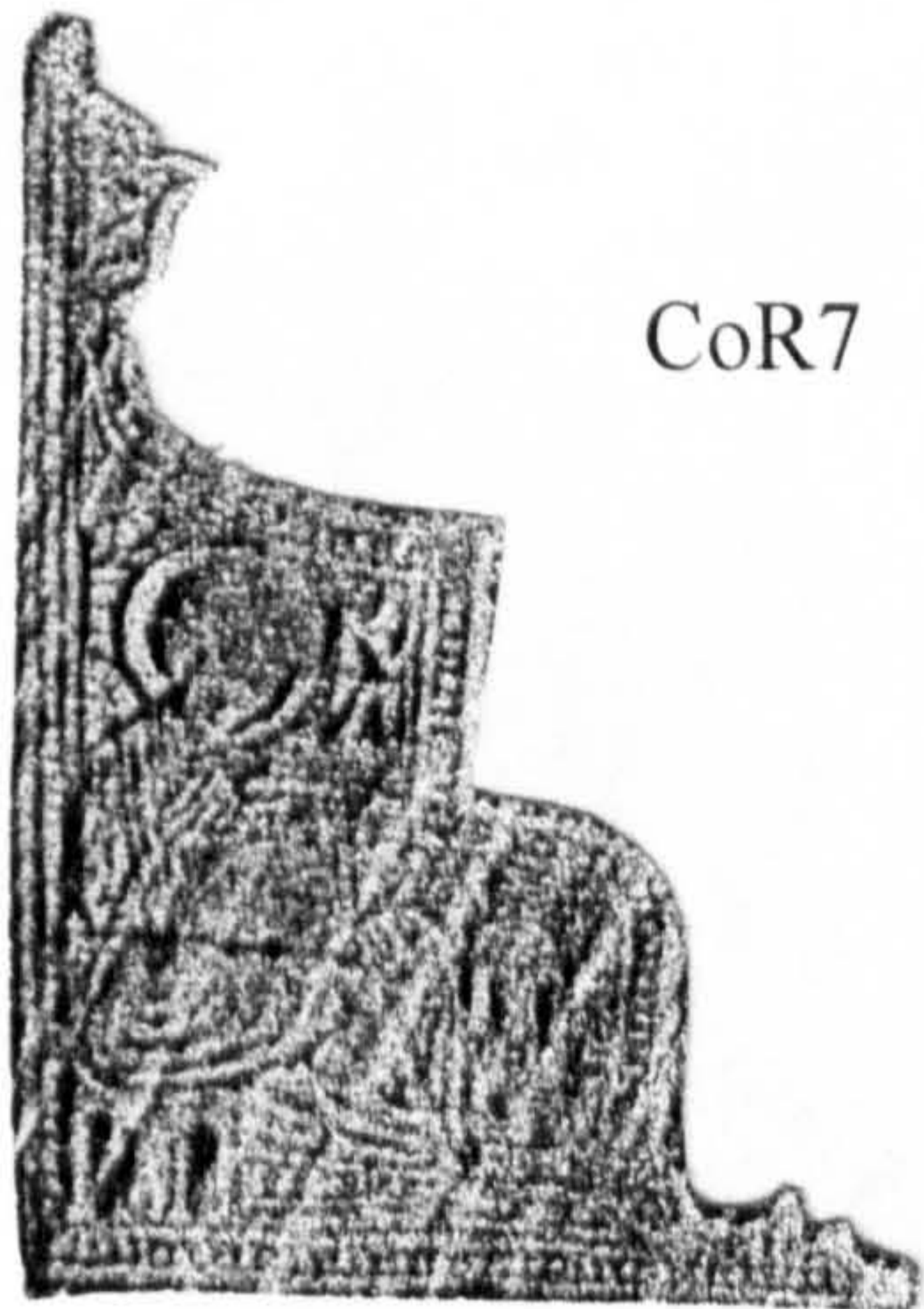

CoR7

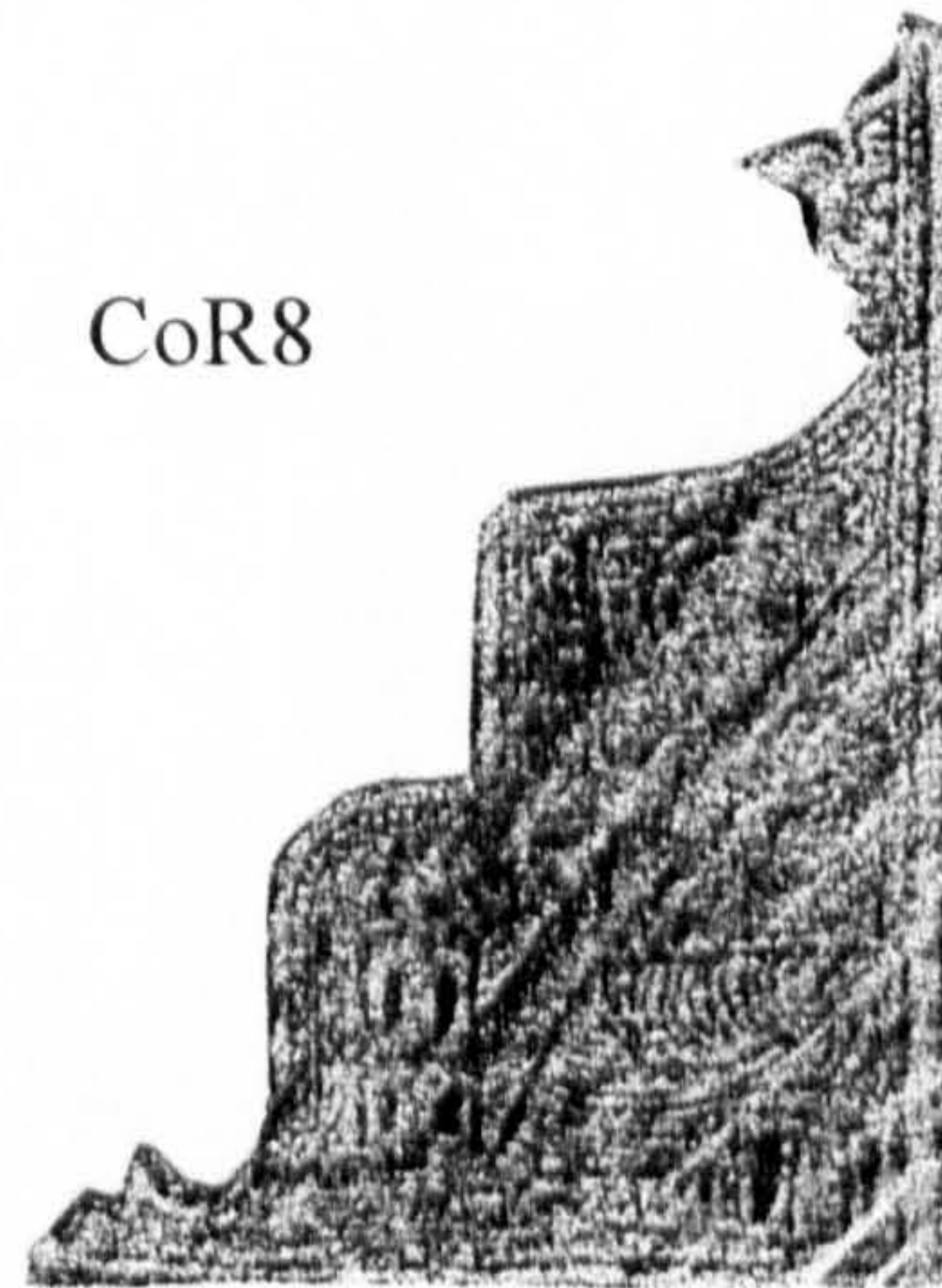

CoR8



CoR27



CoR9



CoR10

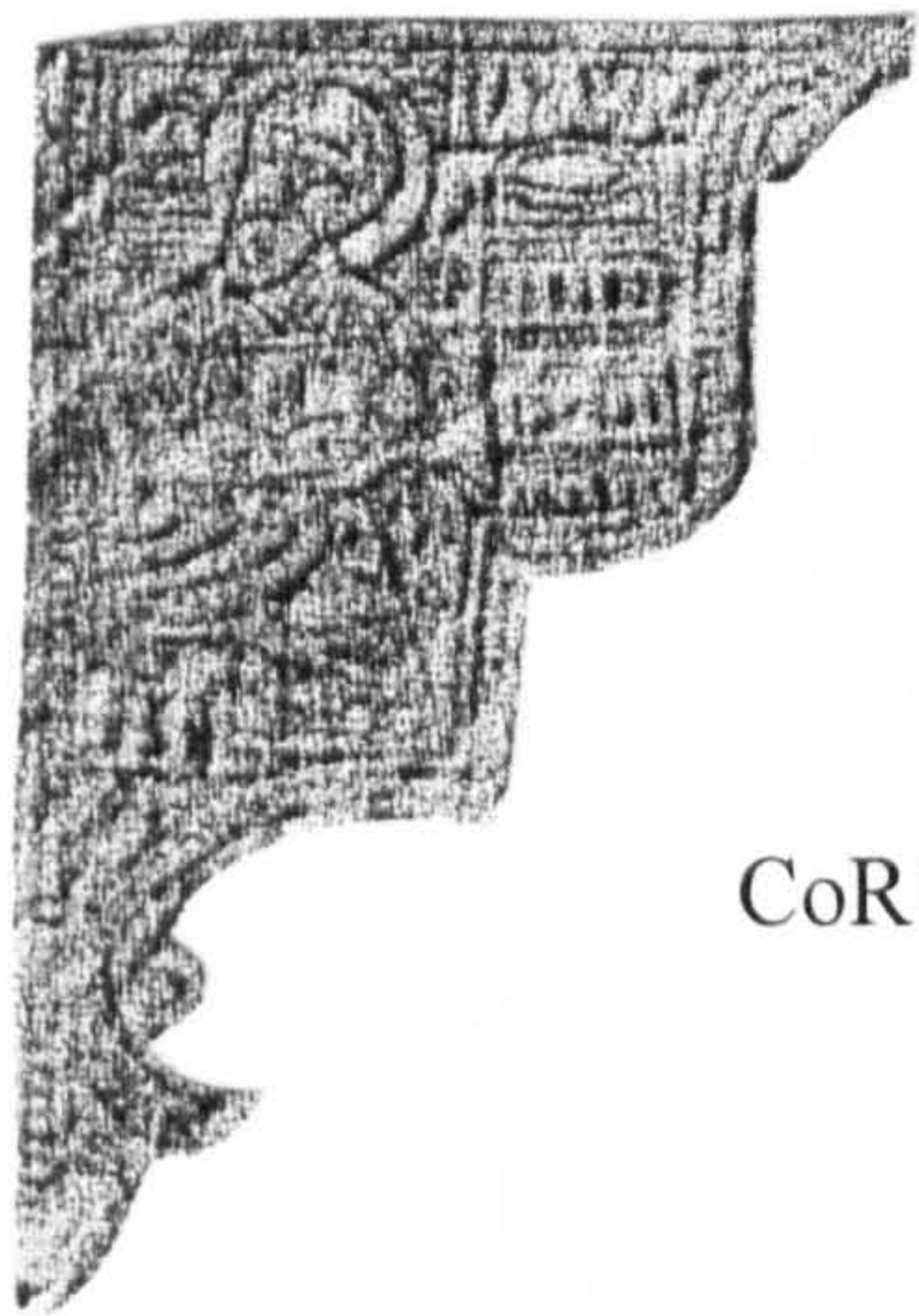

CoR11

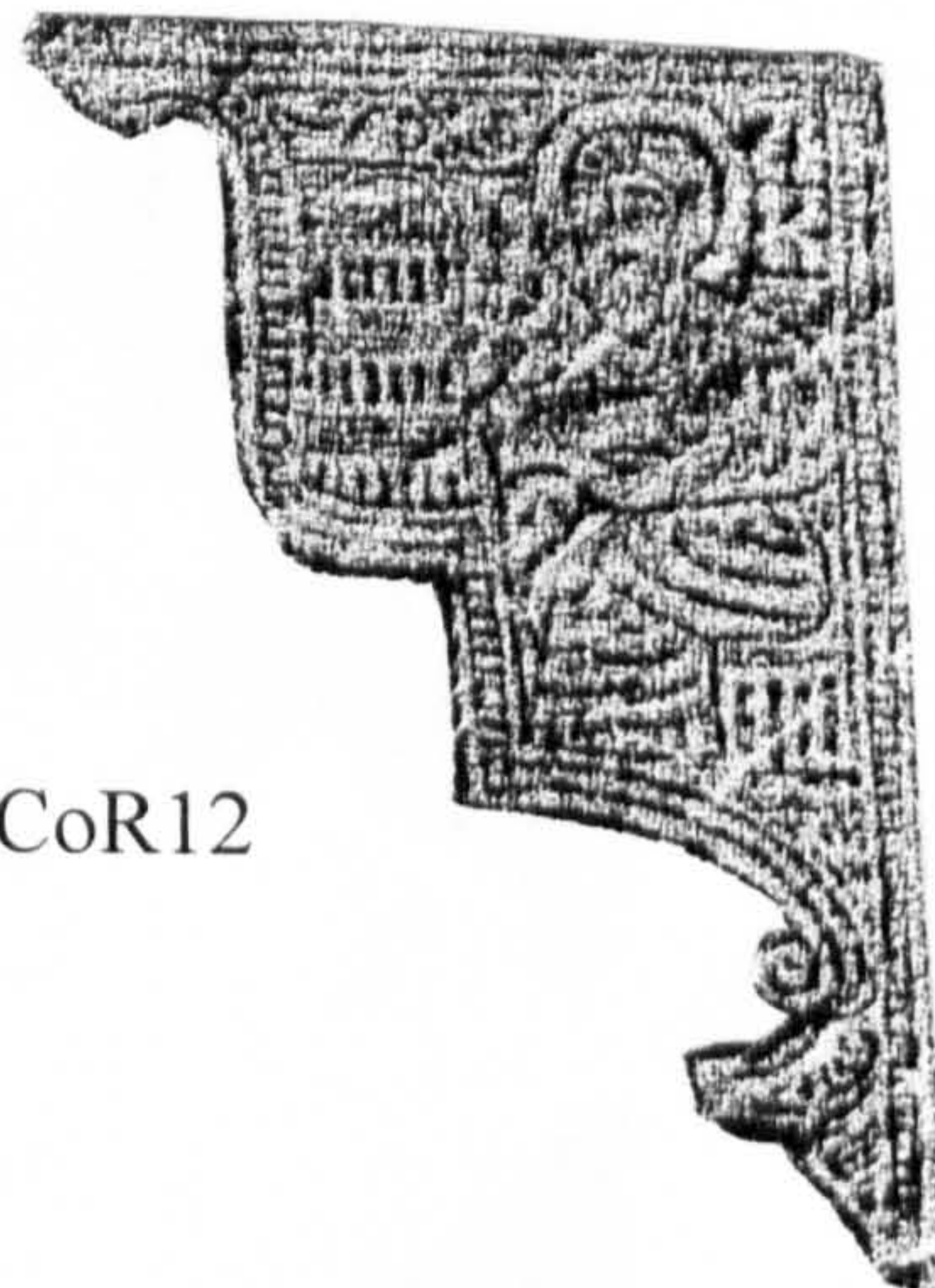

CoR12



CoR13



CoR14

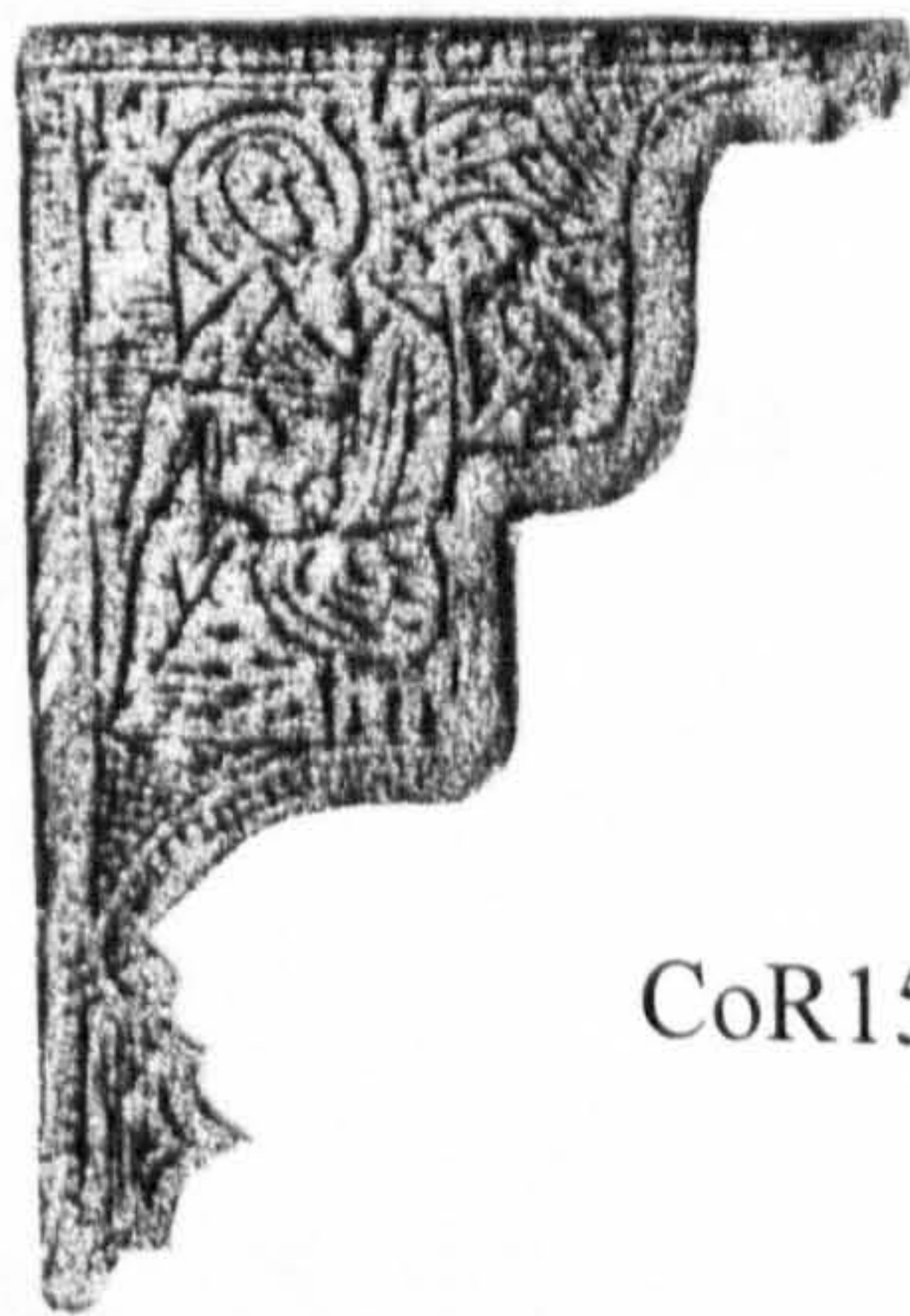

CoR15

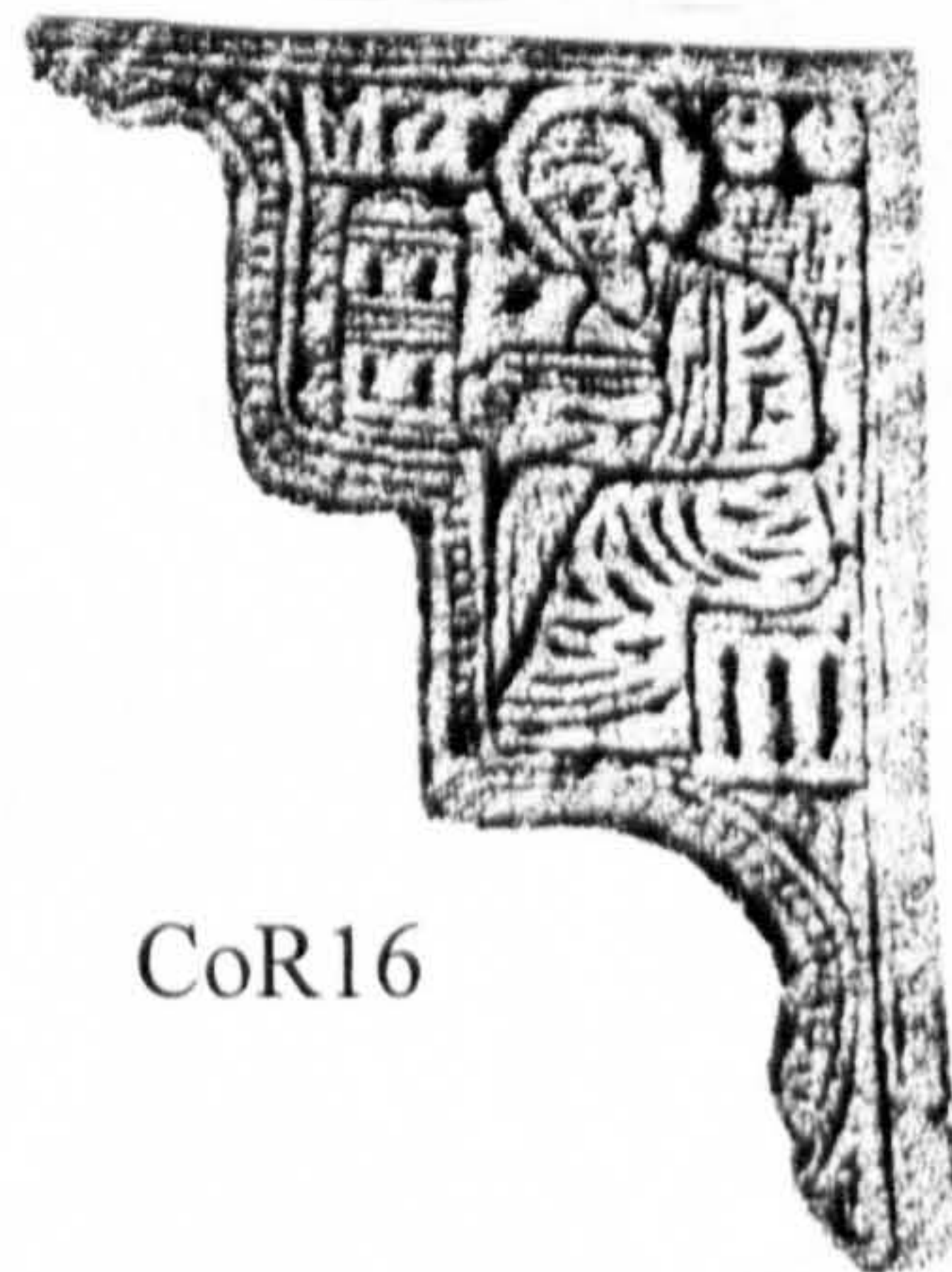

CoR16



CoR17



CoR18

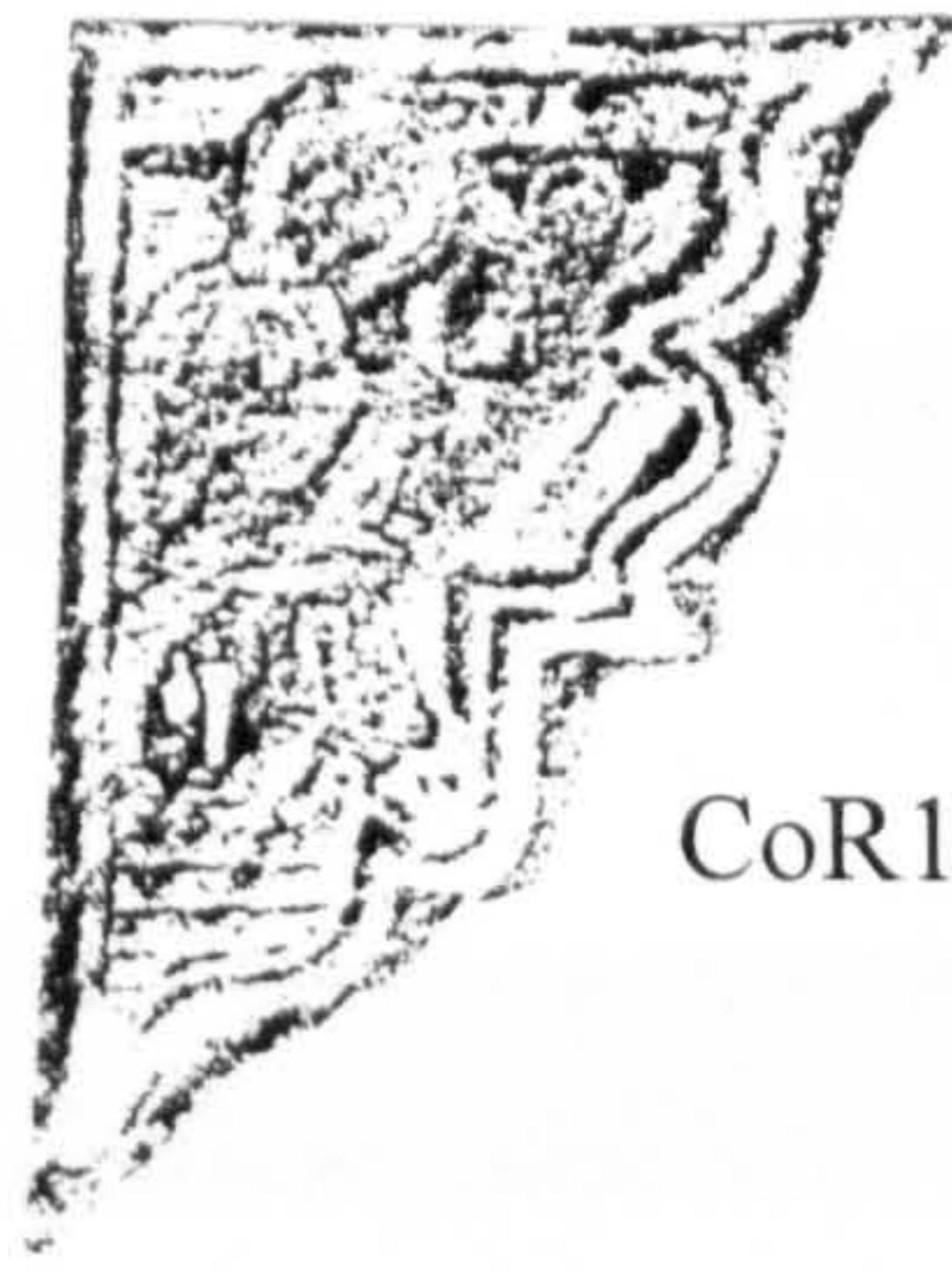

CoR19



CoR20

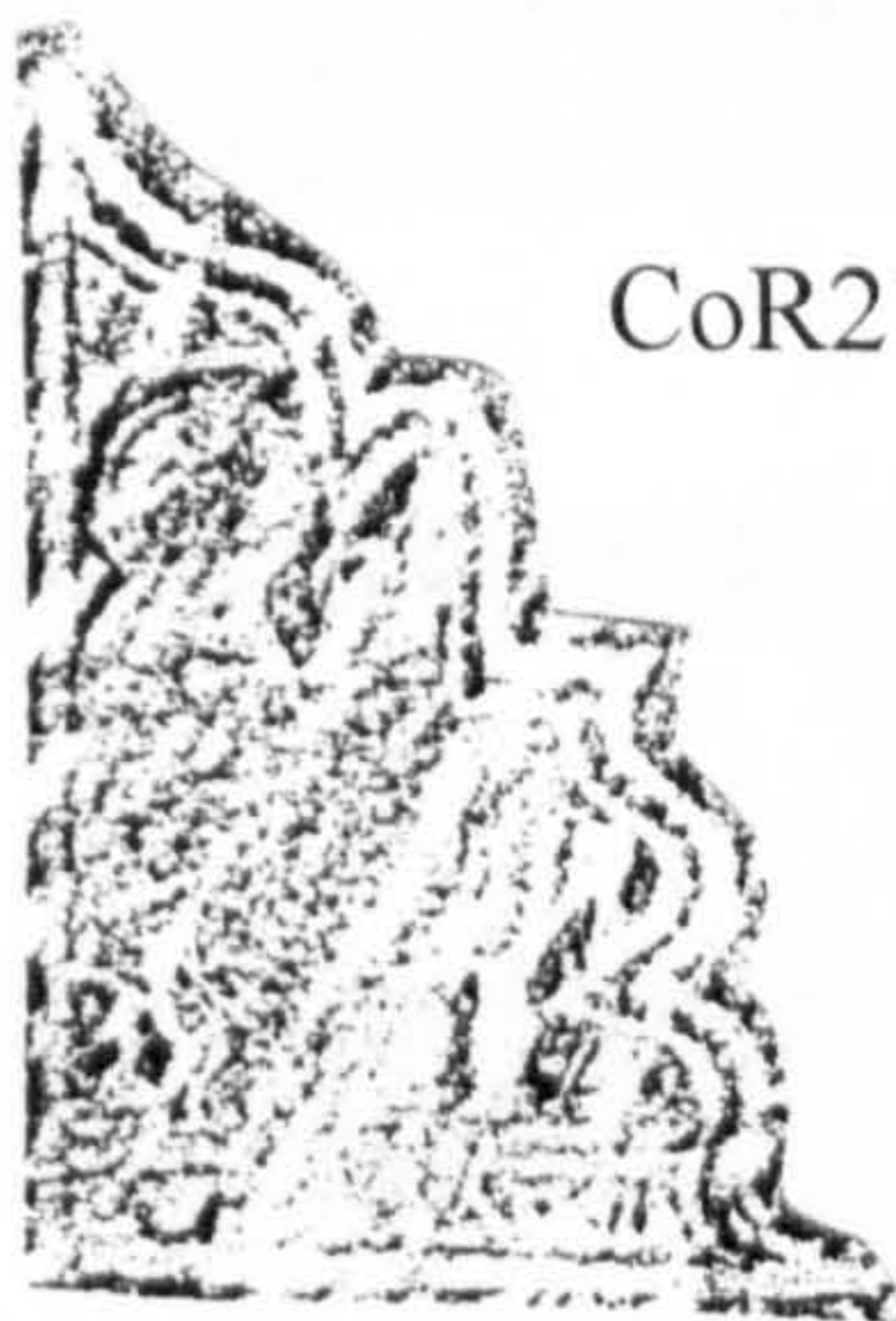

CoR21



CoR22

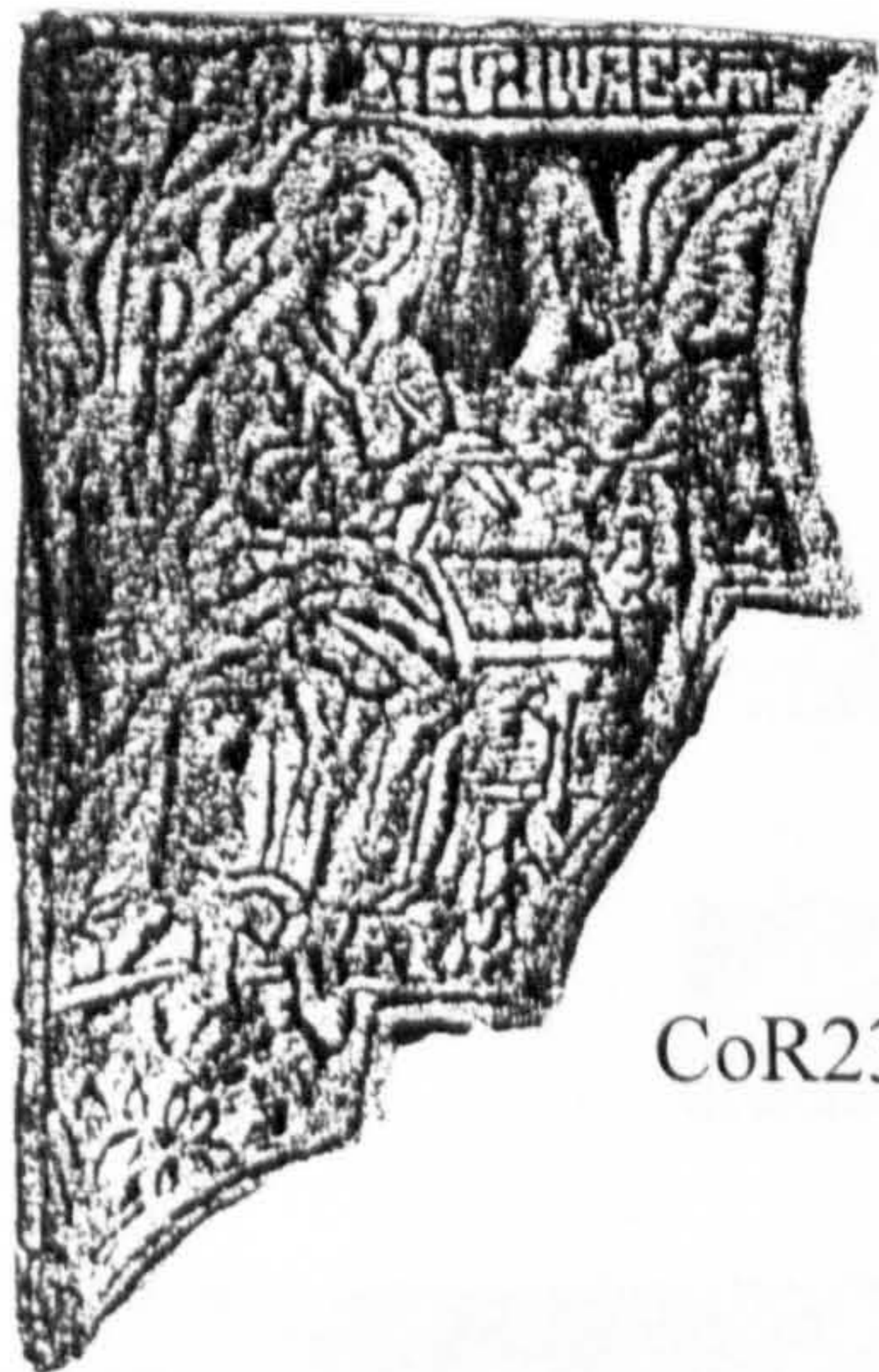

CoR23



CoR24

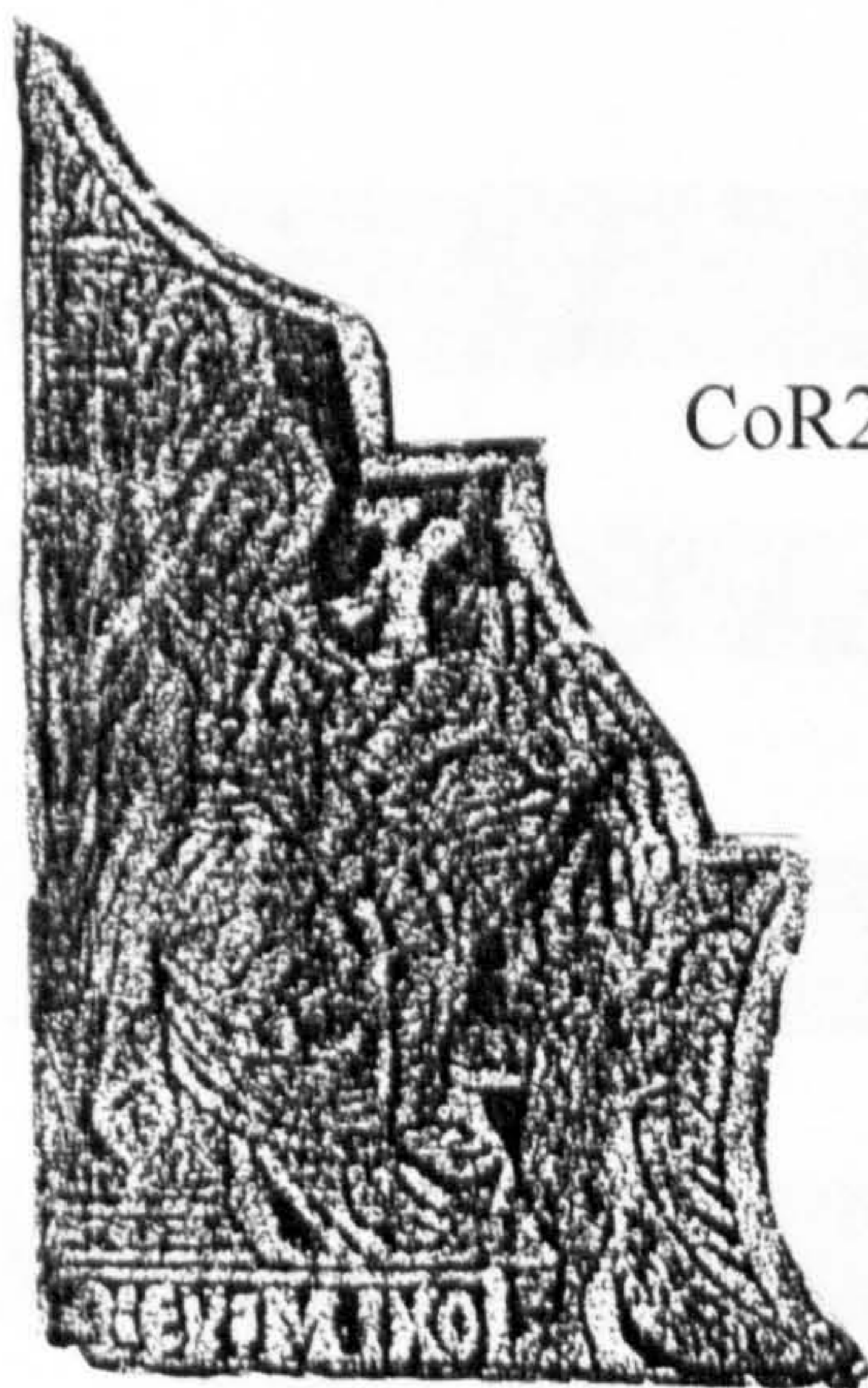

CoR25



CoR26

# CREASERS



C1



C2



C3



C4



C5

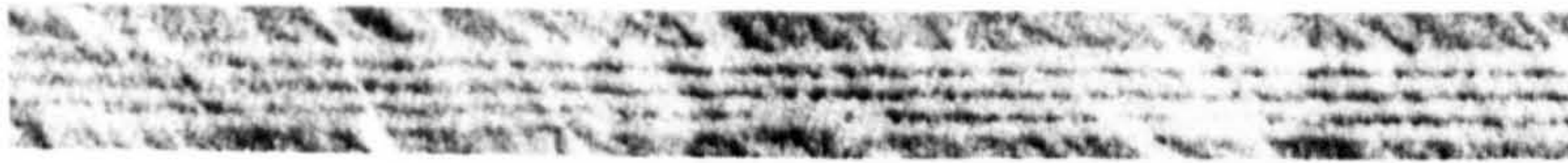

C6



C7



C8



C9

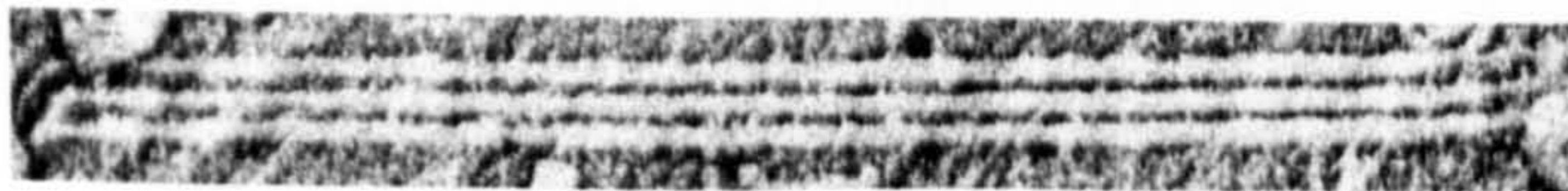

C10



C11



C12

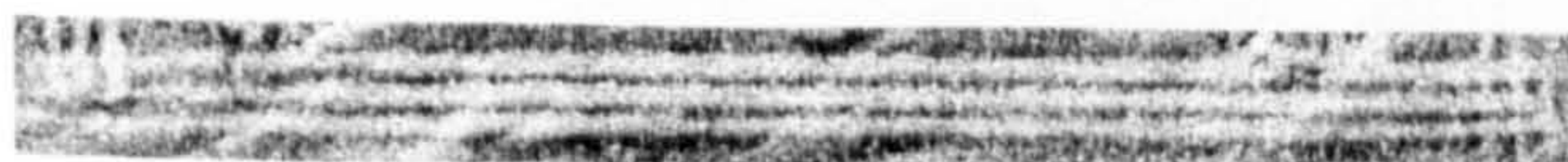

C13

## 5.5. Index of the bindings surveyed and the tools recorded.

Bold letters indicate bindings which have been considered in the statistical analysis in section 4.1. Red colour indicates those bindings which have been attributed to one of the 12 binding ateliers considered in the thesis. The initial in red indicate the specific atelier, IS is for the Ivron Scriptorium bindings, THE is for the Theoklitos bindings, PA is for the Papanephotos bindings, C is for the Cosmas Macedon bindings, CR is for the Cretan bindings, A is for the Antioch bindings, K is for the Klimis bindings, G is for the Giglio bindings, CA is for the Cairo *metochion* bindings, R is for the Raithos bindings, E for the Elusive bindings and NL for the New Library atelier.

Catalogue Num.	Date of Binding	Date of Text	Tools
<b>1.</b> Skiti I. 1	1692/4	1692/4	MuF/c24(?), RoF11, RoF48 (?), RoG16, fillets
<b>2.</b> Skiti I. 3	1709	1709	RoG16, fillets
<b>3.</b> Skiti I. 4	1692	1692	MuF/a51, MuF/a52, CeR35, CeR11(?) and CeF5 or 33, CoF11, fillets
4. I. 0005	16th. c.?	13th. c.	RoF16, MuF/c17, MuG/b5(?), MuF/c21(?), Like MuG/a5, fillets
<b>5.</b> I. 0042 IS	1525	14th. c. & 1525 circa	MuF/a3, MuF/c3, MuF/d19, MuF/d39, MuA/b2, MuG/a6, MuG/c4, C8
<b>6.</b> I. 0046 IS	16th. c. (1 <sup>st</sup> half)	1007	MuF/a3, MuA/b2, MuA/d1, MuG/a6, MuG/c6. C8
<b>7.</b> I. 0146	1611-12?	1611-12	None
<b>8.</b> I. 0147	19th. c. (4 <sup>th</sup> quarter?)	16th. c.	None
<b>9.</b> I. 0173	18th. c.	18th. c.	None
<b>10.</b> I. 0193	19th. c. (4 <sup>th</sup> quarter?)	16th. c. (2nd quarter)	None
<b>11.</b> I. 0205	19th. c.?	1610	None
<b>12.</b> I. 0231	19th. c. (4 <sup>th</sup> quarter)	17th. c.-18th. c.	None
<b>13.</b> I. 0252	1700 ca.	1700 ca.	MuF/a12, MuF/a29, RoG6, CeF14, CoF21, fillets
<b>14.</b> I. 0256	1627	1627	MuF/c24, MuG/a9, RoF27, RoF28, fillets
<b>15.</b> I. 0257	19th. c. (4 <sup>th</sup> quarter?)	1615	None
<b>16.</b> I. 0258 IS	16th. c. (1 <sup>st</sup> half)	13th. c.	MuF/a3, MuF/c3, MuF/c47, MuF/d19, MuF/d39, MuF/c12, MuA/b2, MuA/c1, MuA/d1, MuG/a7, MuG/c6, C8

Catalogue Num.	Date of Binding	Date of Text	Tools
17. I. 0259	19th. c. (4 <sup>th</sup> quarter?)	1534/35	None
18. I. 0260	19th. c. (4 <sup>th</sup> quarter)	1537/38	None
19. I. 0261	1610	1610	MuF/c11(?), MuG/d8(?), RoG1, roF16(?), fillets
20. I. 0267	1690	1690	MuF/a37, RoG16, RoG17, CoF11, CeF5 or CeF33, fillets
21. I. 0278	16th. c. (2 <sup>nd</sup> half)	16th. c. (2nd half)	None
22. I. 0279	17th. c.?	1513	RoF11
23. I. 0289	19th. c. (4 <sup>th</sup> quarter?)	1618	None
24. I. 0297	19th. c. (4 <sup>th</sup> quarter?)	17th. c.	None
25. I. 0299	19th. c. (4 <sup>th</sup> quarter?)	1622	None
26. I. 0304	1622	1622	MuF/c19, MuF/d1, MuF/d7, MuG/b6, fillets
27. I. 0307	17th. c. (2 <sup>nd</sup> quarter)	18th. c.?	MuF/b18, RoG19, fillets
28. I. 0359	19th. c. (4 <sup>th</sup> quarter?)	15th. c.	None
29. I. 0382	19th. c. (4 <sup>th</sup> quarter)	1514	None
30. I. 0388	19th. c. (4 <sup>th</sup> quarter?)	16th. c.	None
31. I. 0392 IS	1534?	1534	MuF/a3, MuF/c12, MuA/b2, MuA/c1, MuA/d1, MuG/a6, MuG/c4, C8
32. I. 0393 PA	19th. c. (4 <sup>th</sup> quarter)	1642	None
33. I. 0395	19th. c. (4 <sup>th</sup> quarter)	1639	None
34. I. 0401	1663	1663	MuF/a43, MuF/a46, RoG18, faint centrepiece, fillets
35. I. 0402	1684	1684	MuF/c11, CeF12, fillets
36. I. 0411	1700 ca.	1700 ca	MuF/a12, MuF/a29, RoG6, CeF14, CeR11, CoF21, fillets
37. I. 0422	19th. c. (4 <sup>th</sup> quarter)	1696	None
38. I. 0423	1586	1586	MuF/a35, MuF/c22, MuF/c23, RoF11, fillets
39. I. 0424	17th. c.?	16th. c.	MuF/a6, MuF/a24, MuF/b7, MuF/a41(?), MuF/c20, CeF10, CeF11, CoR9, CoR10, RoF2 <sup>o</sup> , fillets

Catalogue Num.	Date of Binding	Date of Text	Tools
40. I. 0427	16th. c. (3 <sup>rd</sup> quarter)	1560	MuG/b5, Unidentified, fillets
41. I. 0434	1698	1698	MuF/a5 MuF/a28, MuF/a29, MuF/c13, RoG6, RoG7, CeR11, CeF14, CoF3, CoF4, fillets
42. I. 0436 IS	1512/13?	1512/13	MuF/a3, MuF/c2, MuF/d17, MuF/d39, MuA/b2, MuA/c1, MuA/d1, MuG/a6, C8
43. I. 0458	1652	1625	CeF51, CoF20, RoF3(?), fillets
44. I. 0473 PA	1642	1642	MuF/a14, MuF/c4,, MuG/a6, CeF52, RoF3, RoG4, C11
45. I. 0491	19th. c. (4 <sup>th</sup> quarter?)	17th. c.	None
46. I. 0493	17th. c. -18th c. (late-early)	17th c. (4 <sup>th</sup> quarter)	MuF/a29, MuF/a48, RoG6, CoF3, CeR22, CeR26, fillets
47. I. 0501	1665	1665	None
48. I. 0503	18th. c.?	16th c. (1st half)	MuF/b5, MuF/b6, MuF/b39, MuF/e5, MuF/e7, MuF/a22, CeF6, RoF12, RoF13, fillets
49. I. 0506	17th. c. -18th c. (late-early)	15th. c.	MuF/a15(?), CeF5, CoF4 (?), RoF48, fillets
50. I. 0511	17th. c. -18th c. (late-early)	15th. c.	CeF5, CoF4(?), RoF48, fillets
51. I. 0513	19th. c. (4 <sup>th</sup> quarter)	16th c. (1st quarter)	None
52. I. 0519	18th. c.?	1541/2	None
53. I. 0522	17th. c.	17th. c.	MuF/b1, MuF/b3, MuF/e15, CeR25, CeR27, RoF18, fillets
54. I. 0528 IS	1538	1538	MuF/a3, MuF/d8, MuF/e12, MuA/a4, MuA/c1, MuG/a6, C8
55. I. 0530	18th?	1639/40	MuF/a6(?), MuF/a15(?), RoF2, CeF10, CeF11, CoF4, fillets
56. I. 0564	1679	1679	MuV20, MuF/c45, MuF/b36, MuV2, RoF49 (3 different rolls?), fillets
57. I. 0569	1692	1692	MuF/a12, MuF/a29, RoG6, CeF14, CoF21, fillets
58. I. 0581 IS	17th. c ?	1523	MuF/a6, MuF/a24, MuF/e3, CeF11, CeF10, CoF3, RoF2, RoF17, fillets (tools due to later rebinding)
59. I. 0582	17th. c. (4 <sup>th</sup> quarter)	16th. c. (4th quarter)	MuF/a28, MuF/a39, RoF48, MuG/c7, fillets
60. I. 0583	1697-1707	1697 - 1707	MuF/a12, MuF/a29, RoG6, CeF14, CeR11, CoF21, fillets
61. I. 0584	1707	1707	MuF/a28, MuF/a48, RoG6, RoG7, CeR20, CoR15, CoR16, CoR17, CoR18, fillets
62. I. 0586	1696	1696	MuF/a27, CeF22, CeF33, CeR28, CeR29, CoF12, CoF13, fillets



<b>Catalogue Num.</b>	<b>Date of Binding</b>	<b>Date of Text</b>	<b>Tools</b>
63. I. 0591	19th. c. (4 <sup>th</sup> quarter)	16th c. (2nd quarter)	None
64. I. 0593 IS	1540 ?	1540	MuF/a3, MuF/c3, MuF/d8, MuF/d14, MuF/e12, MuA/a4, MuA/b2, MuA/c1, MuA/d1, MuG/a6, C8
65. I. 0600	1706	1706	MuF/a12, MuF/a29, RoG6, CeR11, CoF21, fillets
66. I. 0608	16th. c. - 17th. c. ?	1337/8	MuA/b6, MuG/b4, MuG/a7, fillets
67. I. 0625 PA	1654	1654	MuF/a14, MuF/c4, MuG/a7, CeR23, CeR24, C10
68. I. 0628	18th. c.?	17th. c.	CeF33, CoF3, RoG16, fillets
69. I. 0644	1685	1685	MuF/a30, MuF/a31, MuF/c16, Like NuG/a6, RoF20, RoF19, Cer18, CeR30, fillets
70. I. 0672	NK	1557	None
71. I. 0673	17th. c. (4 <sup>th</sup> quarter)	14th. c.	RoF48, CeF5(?), CoB(?), fillets
72. I. 0678	19th. c. - 20th. c. (late)	16th c. (1st half)	None
73. I. 0691	19th. c. (4 <sup>th</sup> quarter)	16th c. (1st third)	None
74. I. 0697 IS	1533?	1533	None
75. I. 0712	1666/7	1666/7 (?)	MuF/c8, CeF23 & fillets
76. I. 0724	17th. c. (1 <sup>st</sup> quarter?)	1622 (April)	None
77. I. 0754 IS	16th. c. (2 <sup>nd</sup> quarter)	16th. c. (2nd quarter)	MuA/a4, MuF/c3, MuA/b2, MuA/c1, MuG/a6, C8
78. I. 0755	1677	1677	MuF/b17, MuF/b19, CeR31, CeR32, CoF8, MuF/a41(?), fillets
79. I. 0762	17th. c.?	17th. c.	MuF/c?, MuF/a32, CeF56, fillets
80. I. 0782	19th. c. (4 <sup>th</sup> quarter?)	16th. c.	None
81. I. 0783 IS	1542?	1542	MuF/a3, MuF/c3, MuA/a4, MuA/b2, MuA/d1, MuG/a6, C8
82. I. 0785 THE	17th. c. (1 <sup>st</sup> quarter)	1488	MuF/a3, MuF/c12, MuG/a5, fillets
83. I. 0786	17th. c. (4 <sup>th</sup> quarter?)	16th. c. (2nd quarter)	MuF/a30, MuF/a31, MuF/c16, MuG/a8, RoF20, RoF19, Rog12, CeR14, Cer15 7, fillets
84. I. 0787	17th. c. (4 <sup>th</sup> quarter)	16th. c. (2nd quarter)	MuF/a28, MuF/a29, MuF/c13, RoG6, RoF48, CeF9, CeF14, CeF15, CoF3, CoF4, fillets
85. I. 0788	16th. c. - 17th. c.	1432	MuF/b15, RoF21, creaser(?)

<b>Catalogue Num.</b>	<b>Date of Binding</b>	<b>Date of Text</b>	<b>Tools</b>
<b>86. I. 0790</b>	17th. c. (4 <sup>th</sup> quarter?)	16th. c. (2nd century)	RoF18, RoF20, MuF/a30, MuF/a31, MuF/c16, CeF55, fillets
<b>87. I. 0795</b>	17th. c. (4 <sup>th</sup> quarter)	1537	MuF/a28, MuF/a29, MuF/c13, RoG6, RoF48, CeF9, CeF14, CeF15, CoF3, CoF4, fillets
<b>88. I. 0801</b>	16th. c.	15th. c.	MuF/a74, MuF/a75, MuF/e6 MuF/c46, RoF50, RoF51, fillets
<b>89. I. 0809</b>	20th. c.	1518	None
<b>90. I. 0810 IS</b>	1536?	1536	None
<b>91. I. 0818</b>	18th. c. (1 <sup>st</sup> half)	16th. c.	CoF3, CeR36, CeR37, Similar(?) to RoG17, & various unclear rolls and fillets
<b>92. I. 0833</b>	19th. c. (4 <sup>th</sup> quarter)	1540	None
<b>93. I. 0834</b>	17th. c. (1 <sup>st</sup> quarter)	1514	MuF/c11, MuG/a6, RoG1, RoF16
<b>94. I. 0835 PA</b>	17th. c. (1 <sup>st</sup> half)	1426	MuF/a14, MuF/c4, MuG/a6, CeF52, RoF3, RoG4, C11
<b>95. I. 0837 IS</b>	16th. c. (1 <sup>st</sup> half?)	16th. c. (1st half)	MuF/a3, MuF/c3, MuF/d17, MuF/d19, MuA/b2, MuA/c1, MuA/d1, MuG/a6, MuG/c4, MuG/c6, C8
<b>96. I. 0838 THE</b>	17th. c. (1 <sup>st</sup> quarter)	17th. c.	MuF/a3, MuF/c12, MuG/a5, fillets
<b>97. I. 0839</b>	19th. c. (4 <sup>th</sup> quarter?)	17th. c. (1st half)	None
<b>98. I. 0847</b>	19th. c. (4 <sup>th</sup> quarter)	1900 ca	None
<b>99. I. 0856</b>	19th. c.?	1638	Nk
<b>100. I. 0858</b>	1722	1722	None
<b>101. I. 0862</b>	19th. c. (4th quarter)	1636 (September)	None
<b>102. I. 0864</b>	1601	1601	3 tools very faint and fillets
<b>103. I. 0880</b>	18th. c.?	16th. c. (2nd quarter)	None
<b>104. I. 0899</b>	N.k.	16th. c. (2nd quarter)	None
<b>105. I. 0904</b>	1639, after	1639 & 16th - 17th c.	MuF/a45, MuF/c15, RoF22, 1 unclear tool, fillets
<b>106. I. 0907 IS</b>	16th. c. (1 <sup>st</sup> half?)	16th. c.	MuF/a3, MuF/c3, MuA/b2, MuA/c1, MuG/a6, C8
<b>107. I. 0911</b>	1624/5	1624/5	MuG/a10 (?), MuF/c21(?), CeF28, fillets
<b>108. I. 0927</b>	1682	1682	MuF/a28, MuF/a33, CeF13, RoG13, fillets
<b>109. I. 0928</b>	17th. c.	17th. c.	3 very faint small tools and fillets

Catalogue Num.	Date of Binding	Date of Text	Tools
110. I. 0967	18th. c. (1 <sup>st</sup> half)	18th. c. (1st half)	MuF/c18, MuF/a12, CeF54, CoF23, RoF5, RoG5, fillets
111. I. 0970 C	1689	1686	MuF/a5, RoF48, CeF58, CeR11, CoF4, fillets
112. I. 0971	1737 ?	1737	MuF/a1, MuF/b4, MuF/a25, MuF/a26, CoF1, CeF7, CeF8, RoF14, fillets
113. I. 0978 C	1680 ca	1680 ca.	MuF/a28, RoG6, CeF5, CoF3, fillets
114. I. 0979 C	1680 ca	1680 ca.	MuF/a15(?), RoG6, CeF13, CoF21, fillets
115. I. 0980 C	1680 ca	1680 ca	MuF/a12(?), MuF/a29, RoG6, CeF5(?), CoF21, fillets
116. I. 0983	1762	1762	RoF4, CoF3, CeF16, fillets
117. I. 0991	1670	1670	MuF/a46, Like MuG/d8, RoF23, CeF27, MuG/c8, fillets
118. I. 0993	17th. c. (1 <sup>st</sup> half)	17th. c. (middle)	None
119. I. 1010	1755	1755	MuF/c38, CeR3, thin floral roll, fillets
120. I. 1048 C	1686	1686	MuF/a24?, MuF/a29, RoF48, CeF36, CeR29, CoF3, fillets s
121. I. 1052	17th. c. (4 <sup>th</sup> quarter)	17th. c.	MuF/a76, RoG7, CeF14, CoF21, fillets
122. I. 1053	17th. c.	17th. c.	MuF/c11, Like MuG/d8, Like CeF24, fillets
123. I. 1058	18th. c.	18th. c.	CeF31& fillets
124. I. 1073	18th. c.	18th. c.	MuF/a47, MuF/c13, CeR21, CoF4, RoF48, fillets
125. I. 1074	1682	1682	MuF/a34, MuF/a37, MuF/a44, MuF/b16, MuF/c18, RoF11, RoF25, creaser(?)
126. I. 1078	17th. c.	17th. c.	MuF/a35, Like MuF/c11, RoF11, MuG/a10, fillets
127. I. 1080	17th. c. (3 <sup>rd</sup> quarter)	17th. c. (3rd quarter)	MuF/a36, Like MuF/a43, MuA/a8, MuG/c8, RoG18, RoG15, CeF27, fillets
128. I. 1081	17th. c.?	17th. c.	MuF/b4, Like MuF/a26, RoF1, CeR17, fillets
129. I. 1085	18th. c.	18th. c.	Fillets
130. I. 1092	17th. c. (late)	17th. c.	MuF/a50, MuF/a48, MuF/a49, MuF/c13, RoF24, CoF4, fillets
131. I. 1101	16th. c. - 17th. c.	16th. c. (2nd quarter)	MuA/b6, MuG/b4, MuG/a7, fillets
132. I. 1110	1775 (before of)	1775 (before)	MuF/a72, MuF/a73, MuF/b32, similar to RoF6 (?), RoG2, CoR27, C13

Catalogue Num.	Date of Binding	Date of Text	Tools
133. I. 1112	1671, (before of)	1671 (before)	CeF35
134. I. 1116	17th. c. (4 <sup>th</sup> quarter?)	17th. c. (4th quarter)	CeF(?), CoF9
135. I. 1122	1623	1623	MuF/c12, MuG/a5, CeF32(??), fillets
136. I. 1135	18th. c.?	18th. c.	None
137. I. 1140	17th. c.	17th. c.	MuF/b4, MuF/a11, MuF/e10, CeF9, CeR11, RoF4, RoF6, RoG10, fillets
138. I. 1141	1680	1680	MuF/c8, MuG/a13, DeF23(?), fillets
139. I. 1150	1674	1674	MuF/c18, MuF/a37, MuF/b16, MuF/a34, fillets (?)
140. I. 1166	17th. c.	17th. c.	None
141. I. 1168 PA	17th. c. (1 <sup>st</sup> half?)	17th. c.	MuF/a14, MuF/a38, MuF/c4, CeF52, RoG4, C11
142. I. 1173	17th. c. (early?)	17th. c. (early?)	MuF/a40, MuF/c21, MuG/a12, MuF/c21, MuA/a7, fillets
143. I. 1174	17th. c. (4 <sup>th</sup> quarter)	17th. c.	MuF/a34, MuF/a44, MuF/b16, MuF/c18, RoF25, RoF11, MuF/a43(?), fillets
144. I. 1176	17th. c.	17th. c.	MuF/c20, MuG/a11, CoF22, CeF26, fillets
145. I. 1183 C	1692	1692	MuF/a37?, RoG7, CeF13, CeR11, CoF4, fillets
146. I. 1197	17th. c.	17th. c.	1 centrepiece very faint
147. I. 1200	1674	1674	MuF/c18, MuF/a44, MuF/a34, RoF26, creaser (?)
148. I. 1209	17th. c.	17th. c.	None
149. I. 1211	16th. c. - 17th. c.	16th. c. - 17th. c.	MuF/a23, MuF/e1, fillets
150. I. 1215 THE	17th. c. (1 <sup>st</sup> quarter)	17th. c. (1st quarter)	MuF/c12, MuG/a5, fillets
151. I. 1221 PA	17th. c. (1 <sup>st</sup> half)	17th. c.	MuF/a14, MuF/c4, MuG/a7, MuV2, RoF46, C11
152. I. 1226	1697	1679	CeR33, MuF/b11, MuF/a41, MuF/b29, RoF29, fillets
153. I. 1308	20th. c.	18th. c. (early)	None
154. I. 1337	19th. c. (4 <sup>th</sup> quarter)	1530	None
155. I. 1358	1722 ?	1722	None

Catalogue Num.	Date of Binding	Date of Text	Tools
156. I. 1368	18th. c. (1 <sup>st</sup> quarter)	18th c.	None
157. I. 1447	1807 (September?)	17th c. (1st half)	None
158. I. 1448	17th. c. (4 <sup>th</sup> quarter?)	17th c. (4th quarter) partly	MuF/a52, MuF/a51, MuF/a44, fillets
159. I. 1496	1600	1600	MuF/c44, CeF50, fillets
160. I. 1497	17th. c. ?	17th. c. (1 <sup>st</sup> quarter)	None
161. I. 1498 THE	17th. c. (1 <sup>st</sup> quarter)	1522	MuF/a2, MuF/c12, MuF/c12, MuG/a5, MuV19, fillets
162. I. 1499	16th. c. (3 <sup>rd</sup> quarter)	16th. c. (3 <sup>rd</sup> quarter)	MuF/d18, Muf/c15, MuV7, Muv8, MuV9, MuV10, fillets
163. I. 1500 THE	17th. c. (1 <sup>st</sup> quarter)	1514/15	MuF/a2, MuF/c12, MuG/a5, fillets
164. I. 1501	17th. c. (3 <sup>rd</sup> quarter)	16th. c. (1 <sup>st</sup> half)	MuF/c8, MuF/a9, MuF/d5, RoF15, MuG/a6,
165. I. 1503 THE	16th. c. (3 <sup>rd</sup> quarter)	16th. c. (end)	MuF/c12, MuA/c5, MuG/a5, fillets
166. I. 1505	16th. c. (3 <sup>rd</sup> quarter)	16th. c. (3 <sup>rd</sup> quarter)	MuA/a6, Muf/c14, fillets
167. I. 1506	16th., c. (3 <sup>rd</sup> quarter)	16th. c. (3 <sup>rd</sup> quarter)	MuF/c15, MuF/d18, fillets
168. I. 1508	1603	1603	CeF30, CoF9
169. I. 1513	1613	1613	None
170. I. 1514	1641	1641	More than 20 tools & fillets (NR). Gold and silver tooled Romanian(?) binding
171. I. 1518	1603	1603	Like MuF/c11, Like MuG/a6, CeF24, fillets
172. I. 1519	1615/16	1615/16	MuF/c16, Like MuG/a6, CeF29, CeF1, fillets
173. I. 1522	1685	1685	MuF/b14, MuF/b38, MuA/a2, CoR1, CoR2, CoR3, CoR4, CeR5, CeR2, RoG9, & fillets and 2 unclear tiny tools
174. I. 1524	1613/14	1613/14	Like MuF/c11, Like MuG/a6, CeF25, CeF29, fillets
175. I. 1525	17th. c. (2 <sup>nd</sup> quarter)	17th c. (middle)	None
176. I. 1527	1641	1641	More than 20 tools & fillets (NR). Gold and silver tooled Romanian(?) binding
177. I. 1529	1604	1604	No tools, painted
178. I. 1530	1634	1634	None

Catalogue Num.	Date of Binding	Date of Text	Tools
179. I. 1531	NK	1679	None
180. I. 1532	17th. c. (4 <sup>th</sup> quarter?)	1643?	MuF/a33, CeF33, CoF14, RoF48, CeR19, CoR5, CoR6, CoR7, CoR8, fillets
181. I. 1533 THE	1622	1622	MuF/c12, MuG/a5, CeF32, fillets
182. I. 1552 THE	1606/7	1606/7	MuF/c12, MuG/a5, fillets
183. I. 1555	19th. c- 20th c.	1613/14	None
184. I. 1557	1621 & later	1621	None (only metal fittings)
185. I. 1585 IS	1540?	1540	MuA/b2, C8
186. I. 1588 IS	1544?	1544	N.k.
187. I. 1589 IS	1538?	1538	MuF/a3, MuF/c3, MuF/d8, MuF/e12, MuA/b2, MuA/c1, MuG/a6, C8
188. I. 1590	16th. c.?	1516	MuF/c11, RoF16, MuG/a6,
189. I. 1591	17th. c.?	1522/23	MuF/c11, MuG/a6, CeF, fillets
190. I. 1595	17th. c.?	1522/23	MuF/c11, MuG/a6, CeF, 1 fillets
191. I. 1599	NK	1540	MuF/a3(?), MuF/a27, CeF54 , fillets
192. I. 1604	19th. c.	1611	MuF/b18, RoG19, fillets
193. I. 1605	18th. c. (early)	1647	Fillets
194. I. 1611	1676	1675	MuF/b19, MuG/a8(?), CeF17, CeF18, CoF7, fillets
195. I. 1613	17th. c. ?	17th c. (1st quarter)	None
196. I. 1614	18th. c.?	17th. c. (2nd half)	Fillets
197. I. 1615	1643 ?	1643 (September)	MuA/a1, fillets
198. I. 1618	18th. c.?	17th. c. (early)	None
199. I. 1619	18th. c?	1638	2 small tools and 2 rolls all very faint.
200. I. 1622	1650	1650	MuF/c12, Un1, fillets
201. I. 1624	18th. c. ?	1640 (September)	MuF/b7, MuF/a6, MuF/a24, RoF2, fillets

Catalogue Num.	Date of Binding	Date of Text	Tools
202. I. 1626	1645/7	1645/7	MuF/e40, CeF34, CoF10, RoG14, fillets
203. I. 1627	19th. c.	1618	NR
204. I. 1631	1717	1717	MuF/b7, MuF/a6, MuF/a62(?), MuF/c3, CeF11, RoF2, fillets
205. I. 1656	1702	1702	MuF/b1, MuF/b2, MuF/b3, CeR13, RoF1, RoF6, & fillets
206. S. 0014	17th. c. (1 <sup>st</sup> half)	12th. c.-13th. c.	MuV4, MuA/c3, MuF/d22, MuA/b10, creaser(?)
207. S. 0027 G	17th. c. (1 <sup>st</sup> half)	1452	MuF/c1, MuV3, MuV4, RoF43, C6
208. S. 0030 A	15th c.-16th c. (late-early?)	9th. c.	MuF/a71, MuF/e25, MuA/b7, C2
209. S. 0033	14th. c.?	9th. c.	MuG/c9, fillets
210. S. 0043	15th. c. -16th. c.	12th. c.-13th. c.	MuG/a10 (?), RoF/44, MuF/c39, MuF/e4, MuV16
211. S. 0044	15th. c. - 16th. c.	1121/1122 & late 13th. c.	None
212. S. 0046 G	17th. c. (1 <sup>st</sup> half)	14th. c.-15th. c.	MuF/c1, MuV3, MuV4, RoF10, C5
213. S. 0061 G	17th. c. (1 <sup>st</sup> half)	12th. c.	MuF/c1, MuA/b4, MuV4, fillets
214. S. 0069	1638	1638	Many tools (not catalogued)
215. S. 0070	16th. c. (2 <sup>nd</sup> half)	1488?	MuF/a17, MuF/b10, MuF/c13, MuF/c49, MuF/d12, MuF/d14, MuV5, RoG35, fillets
216. S. 0072	17th. c. (1 <sup>st</sup> half)	17th. c. (1st half)	MuF/c1, MuA/b4, MuG/b3, MuV4, MuF/c36, RoF43, creaser (?)
217. S. 0074	1620?	1620	MuF/c1, MuA/b4(?), MuG/b3, MuV4, RoF/43, creaser(?)
218. S. 0075	17th. c. (3 <sup>rd</sup> quarter?)	16th. c.	MuF/d25, RoF45(?), fillets
219. S. 0076 R	1654 ?	1654	MuF/d25 , fillets
220. S. 0077	1654	1654	MuF/d25, fillets
221. S. 0078	1634?	1634	Fillets
222. S. 0080	1664	1664	MuF/a7, MuF/a8, MuF/c7, MuF/c41, MuF/d1, MuF/d7, MuF/d36, MuG/a4, fillets
223. S. 0087	1564?	1565	MuF/a77, MuF/d40, MuF/e41, MuF/b35, MuA/c10, creaser(?)
224. S. 0088 R	17th. c. (2 <sup>nd</sup> half)	17th. c.	MuA/b5, fillets
225. S. 0089	1706?	1659	MuF/a61(?), creaser (?)

Catalogue Num.	Date of Binding	Date of Text	Tools
226. S. 0091	18th. c. (before 1720?)	1648	Filletts
227. S. 0094	14th. c?	1294	None
228. S. 0106	16th. c. - 17th. c?		MuF/b10?, MuF/e28, RoF/47, filletts
229. S. 0108	17th. c.	17th. c.	Nr
230. S. 0109	17th. c. (1 <sup>st</sup> half)	15th. c.-16th. c.	CeR?, MuA/b12, MuA/b4, MuA/c3, RoF35, filletts
231. S. 0112	17th. c.?	15th. c.	MuF/c27, MuF/d4, filletts
232. S. 0117	1544	1544	MuF/b31, MuF/c42, CeF46, CoF18, MuG/b9, 3 'round' filletts, 1 fillet
233. S. 0120	17th. c. (1 <sup>st</sup> half)	16th. c.	MuV3, filletts
234. S. 0157	16th. c.	1127-1157/8 ca	MuF/d41, MuA/d7, MuA/b4(?), filletts
235. S. 0165 CR	15th. c. (1 <sup>st</sup> half?)	15th. c. (1st half?)	MuF/a63, MuF/d31, MuF/d32, MuF/d33, MuF/e2, MuA/a13, MuA/b4(?), MuG/a22, MuV15, CI
236. S. 0173	17th. c?	11th. c.-12th. c.	Filletts
237. S. 0175 G	17th. c. (1 <sup>st</sup> half)	11th. c.-12th. c.	MuF/c1, RoF10, C5
238. S. 0178	16th. c. (before 1577)	13th. c.	MuF/a70, MuF/b34, MuG/c12, filletts
239. S. 0201	1244?	1244	None
240. S. 0202	17th. c. (2 <sup>nd</sup> quarter)	14th. c.	MuF/c1, MuF/b28(?), RoF43, filletts
241. S. 0203	16th. c.	16th. c.	Leather panel? (Islamic binding with flap)
242. S. 0213	NK	967	None
243. S. 0216 K	16th. c (2 <sup>nd</sup> quarter?)	12th. c. (2nd half) & 15th	MuF/a16, MuF/b10, MuF/c3, MuF/c49, MuV5, C4
244. S. 0237	15th. c. -16th c?	12th. c. (1st half)	MuA/b9, MuF/a53, MuF/d21, RoF30, MuG/a14, filletts
245. S. 0269	17th. c. (1 <sup>st</sup> half?)	15th. c.	MuF/c30, MuF/d3(?), MuF/d23(?), MuG/b3, MuA/d2, filletts
246. S. 0297	17th. c. (1 <sup>st</sup> half)	1510	MuF/c30, MuF/d24, filletts
247. S. 0339	15th. c. (2nd half)	1150	MuF/c38, MuF/d26, MuF/d28, MuF/d29, MuF/e42, MuA/c8
248. S. 0356 CA	1633	10th. c.	MuF/c6, MuF/d3, MuF/e16, MuF/e17, RoF10, filletts
249. S. 0361 G	1632	10th. c.-11th. c.	MuF/c1, MuV4, C6



Catalogue Num.	Date of Binding	Date of Text	Tools
250. S. 0375	16th. c. (1 <sup>st</sup> half)	892/893?	MuF/a62, MuF/c38, MuF/d26, MuF/d28, MuF/d29, MuF/e42, MuA/a14, MuA/c8, C1
251. S. 0379	17th. c. (2 <sup>nd</sup> half)	11th. c.	Unclear, fillets
252. S. 0403 N	1733	15th. c.	RoF7, CeF57, CeR6, fillets
253. S. 0408 G	1632	1371	MuF/c1, MuA/b4, MuV4, C5
254. S. 0420 K	16th. c. (2 <sup>nd</sup> half?)	10th. c.- 11th. c.	MuF/a16, MuF/b10, MuF/c3, MuF/c33, MuF/d12, MuF/e13, MuA/c3, RoF35(?), C4
255. S. 0425	15th. c.	15th. c.	MuA/b8, MuA/a9, MuF/e26, MuF/d20, MuG/A6?, MuG/b7, fillets
256. S. 0426 R	1653	1653	MuA/b5, fillets
257. S. 0433 R	1652	1652	MuA/b5, RoF/40, fillets
258. S. 0443	18th. c.?	18th. c.	MuF/c13, CeF5, RoF31, fillets
259. S. 0448 G	1637	1004	MuF/c1, RoF43(?), C5
260. S. 0475	17th. c. (2 <sup>nd</sup> half)	17th. c.	MuF/b17?, fillets.
261. S. 0500 G	1632	1063 ca.	MuF/c1, MuA/b4, MuV3, CeR4, RoF43(?), C6
262. S. 0520 G	17th. c. (1 <sup>st</sup> half)	11th. c.	MuF/c1, MuA/b4 (?), MuG/b3, MuV4, C7
263. S. 0573 G	1627	1452	MuF/c1, MuG/b3, MuV4, C7
264. S. 0574 CA	17th. c. (1 <sup>st</sup> half)	1465	MuF/c13, MuF/e16, RoF10, fillets
265. S. 0585 G	1626	1453	MuV4, RoF43, C7
266. S. 0604 K	16th. c. (2 <sup>nd</sup> half)	15th. c.-16th. c.	MuF/a16, MuF/b10, MuF/c33, MuF/c37, MuF/d12, MuF/e13, MuF/c49, MuA/c3, MuV3, RoF35(?), C4
267. S. 0605 G	1639	15th. c.-16th. c.	MuF/c1, MuG/b3, MuV4, C5
268. S. 0615 G	17th. c. (1st half)	15th. c.	MuF/c1, MuV3, MuV4, RoF10, RoF37, C6
269. S. 0619 E	17th. c. (3 <sup>rd</sup> quarter)	15th. c.	MuF/a7, MuF/a8 MuF/c7, MuF/c41, MuF/d1, MuF/d7, MuG/a1, MuG/a4, fillets
270. S. 0628	16th. c. (late?)	1457	MuF/c49, MuV3, MuF/c33, Unidentified floral roll (RoF35?), fillets
271. S. 0629 E	17th. c. (3 <sup>rd</sup> quarter)	15th. c.	MuF/a7, MuF/a8, MuF/c7, MuF/c41, MuG/a1, MuG/a4, fillets
272. S. 0634 E	17th. c. (3 <sup>rd</sup> quarter)	15th. c.	MuF/a7, MuF/a8, MuG/a4, MuF/d7, MuF/d1, MuF/d36, MuF/c7, fillets

Catalogue Num.	Date of Binding	Date of Text	Tools
273. S. 0639	17th. c.	1484	MuF/e28, RoF31, C12
274. S. 0649	16th. c. (late?)	15th. c.	MuF/b12, MuF/b13,
275. S. 0663 CR	1520 ?	1520	MuF/a13, MuF/d10, MuF/d29, MuA/a3, MuA/c2, MuA/c4, C1
276. S. 0670	14th. c. - 15th. c. ?	1292	None
277. S. 0678 E	1666 (and later rebacking)	1666	MuF/a7, MuF/a8, MuF/c7, MuF/c41, MuF/d1, MuF/d7, MuG/a4, fillets
278. S. 0710 R	17 <sup>th</sup> c. (2 <sup>nd</sup> half)	17 <sup>th</sup> c.	MuA/b5, fillets
279. S. 0747 G	17th. c. (1 <sup>st</sup> half)	15th. c.	MuF/c1, MuG/b3, MuV4, C7
280. S. 0763 G	1636	16th. c.	MuF/c1, MuF/d4, MuV3, MuV4, C6
281. S. 0764 R	17th. c. (1 <sup>st</sup> half)	15th. c. (1st half)?	MuA/b5, fillets
282. S. 0788	1614?	15th. c.	MuF/e28, RoF10, RoF43,
283. S. 0803 E	17th. c. (3 <sup>rd</sup> quarter)	15th. c.-16th. c.	MuF/a7, MuF/a8, MuF/c41, MuF/d1, MuF/d7, MuG/a1, MuG/a4, MuG/b10, fillets
284. S. 0804 G	1627-8	15th. c.	MuF/c1, MuV4, C6
285. S. 0806 A	16th. c. (1 <sup>st</sup> half?)	16th. c. (1st half)	MuF/a69, MuF/a71, MuF/a78, MuF/c26, MuF/d23, MuF/e25, MuA/a10, MuA/b11, MuA/b17, MuG/a15, MuG/b3, MuG/b8, MuV11, C2
286. S. 0808 E	17th. c. (3 <sup>rd</sup> quarter)	15th. c.	MuF/a7, MuF/a8, MuF/c7, MuF/c41, MuF/d1, MuF/d2, MuF/d6, MuF/d7, MuG/a1, MuG/a4, fillets
287. S. 0931 R	1664	14th. c. - 15th. c.	MuA/b5, fillets
288. S. 0968	1429?	1429	MuF/c40, MuF/d38, MuA/a13(?), MuA/b10, MuV15, MuG/a13(?), fillets
289. S. 0975 A	16th. c. (1 <sup>st</sup> half)	16th. c.	MuF/a71, MuF/a78, MuF/c26, MuF/d23 MuF/e25, MuA/b17, MuG/b3, C2
290. S. 0985 CR	16th. c.	16th. c. (middle)	MuF/c40, MuF/d38, MuA/a13(?), MuA/b10, MuG/a13(?), MuV15, fillets
291. S. 1046	1654	1654	1 centrepiece, 1 cornerpiece, 1 fillet
292. S. 1047	1685?	1685?	1 centrepiece, 1 cornerpiece, 1 fillets
293. S. 1048 G	1637	16th. c.- 17th. c.	MuF/c1, MuG/b3, MuV4, C5
294. S. 1110 E	17th (3 <sup>rd</sup> quarter)	15th. c.-16th. c. (before	MuF/a7, MuF/a8, MuF/c7, MuF/c41, MuF/d1, MuF/d7, MuG/a4, fillets
295. S. 1136	1702 ?	1702	CoF16, CeF39,
296. S. 1159 G	17th. c. (1 <sup>st</sup> half)	17th. c.	MuF/c1, MuA/b4, MuV4, C7

Catalogue Num.	Date of Binding	Date of Text	Tools
297. S. 1162	16th. c. (1 <sup>st</sup> half?)	15th. c.-16th. c.?	MuG/b3, MuF/c1, MuF/c30, MuF/d22, MuA/d2, MuA/d6, fillets
298. S. 1171 G	1632	16th. c.	MuF/c1, MuF/d4, MuV4, C7
299. S. 1174	18th. c (1 <sup>st</sup> half?)	17th. c.?	Fillets
300. S. 1194 CR	1491	1491	MuF/a66, MuF/d20, MuF/d27, MuF/d31, MuF/d33, MuF/e35, MuA/c7, MuG/b11, MuG/c11, fillets
301. S. 1207	17th. c.?	14th. c.	MuF/c31, MuF/c32, MuF/d34, MuG/a18, MuA/d4, MuA/a12.
302. S. 1234 CR	1469	1469	MuF/a66, MuF/d31, MuF/d32, MuF/d33, MuF/e2, MuF/e35, MuA/c7, fillets
303. S. 1246	1691	1691	RoF48, CeR21, CoF3 + 1 centerpiece & 1 single tool not numbered so far
304. S. 1247	15th. c.?	15th. c.	None
305. S. 1262	1437	1437	MuF/c48, MuF/c5, MuG/a2, MuG/b12, MuF/d16, MuA/b1,
306. S. 1297	1665	1665	CeF43, CeR44, CoF17, RoG20(4different rolls), MuF/a56, MuF/b26, MuF/e30, MuF/b33
307. S. 1334	1567	1567	MuF/e32, MuF/e33, MuV12
308. S. 1336	17th. c.?	1564	Unclear
309. S. 1343 CR	15th. c. (2 <sup>nd</sup> -3 <sup>rd</sup> quarter?)	1464 ?	None
310. S. 1370 NL	18th. c (1 <sup>st</sup> quarter?)	18th. c.	MuF/b8, MuV1, CeF2, CeF57, fillets
311. S. 1400	17th. c. - 18th. c.	16th. c.	CeR41, CeR42, MuF/c25, MuF/b17, RoG6
312. S. 1418	18th. c. (1 <sup>st</sup> half)	18th. c.	CeF40, fillets
313. S. 1421 NL	18th. c. (1 <sup>st</sup> half)	18th. c.	Fillets
314. S. 1441	1802	1802	CeR47, CeR48, RoF36, MuF/b20, MuF/c29, MuF/a58, 1 tiny indented roll , 1 fillet
315. S. 1461 NL	18th. c. (1 <sup>st</sup> half)	17th. c.	MuV1, RoF7, fillets
316. S. 1464 NL	1700	1223	RoF7, CeF57, CeR16, fillets
317. S. 1468	18th. C	18th. c.	CoF6, CeF5, Ro28, fillets
318. S. 1469 CR	1689	1689	MuF/a37, MuF/a41, MuF/b21, MuF/b22, RoG16, CeR35, CeR38, CoF11, CoR11, CoR12, CoR13, CoR14, fillets
319. S. 1478 CR	1690	1690	MuF/a5, RoG7, CeF9, CeR11, CoF4, fillets

Catalogue Num.	Date of Binding	Date of Text	Tools
320. S. 1496	17th. c.	17th. c.	MuF/c44, CeF439, fillets
321. S. 1509	17th. c. (late)	17th. c.	MuF/b7, MuF/b37, MuF/a15, CeR12, CeF4, RoF18, fillets
322. S. 1518	1706	1706	MuF/b30, MuF/a21, MuF/a20, RoG8, CeR7, CeR8, fillets
323. S. 1542	18th. c.	18th. c.	RoG6?, fillets
324. S. 1554	16th. c. (2 <sup>nd</sup> half)	1465	MuF/b10, MuF/e13, MuG/b8(?), RoF45(?), fillets
325. S. 1558	17th. c.	17th. c.	CeF44 & tiny tool unclear
326. S. 1595	18th. c. ?	1695	MuV6, fillets
327. S. 1611	18th. c. (1 <sup>st</sup> half?)	1510	Filets
328. S. 1618	16th. c.?	16th. c.	MuF/a65, oblong floral (?) tool unidentified
329. S. 1627	18th. c. (1 <sup>st</sup> half)	1361	MuV1, CeR6, CeF57, RoF7, fillets
330. S. 1629	18th. c. (1 <sup>st</sup> half)	14th. c.	MuV1, RoF7, CeR6, CeF57, fillets
331. S. 1630	1643 ?	1643?	MuF/c3, MuF/d4, & fillets
332. S. 1676 NL	18th. c. (1 <sup>st</sup> half?)	18th. c.	MuF/b8, RoF42, CeF2, CeF57, fillets
333. S. 1683 NL	18th. c. (1 <sup>st</sup> half?)	17th. c.	Fillets
334. S. 1689	18th. c. (1 <sup>st</sup> half)	18th. c.	RoF7, CeF48
335. S. 1691	16th. c. - 17th. c?	16th. c.-17th. c.	MuF/a4, MuF/d9, MuF/c9, MuG/b1, fillets
336. S. 1695	17th. c.-18th c?	1609	Unclear
337. S. 1701 NL	1733	17th. c.	MuV1, RoF7, CeF57, fillets
338. S. 1732	1602	1602	CeF3, CoF5, fillets
339. S. 1756	17th. c.	1544	None
340. S. 1759	1684 ?	1684	Fillets
341. S. 1768 R	17th. c. (2 <sup>nd</sup> half)	15th. c.-16th. c.	MuA/b5, RoF43, MuF/a59, fillets
342. S. 1793 K	16th. c. (2 <sup>nd</sup> half)	16th. c.	MuF/a16, MuF/a17, MuF/b10, MuF/c3, MuF/d11, MuF/d12, MuF/d13, MuF/d14, MuF/e13, MuA/c3, MuV5, C4

<b>Catalogue Num.</b>	<b>Date of Binding</b>	<b>Date of Text</b>	<b>Tools</b>
343. S. 1814 R	1660	1660	MuA/b5, fillets
344. S. 1819 NL	18th. c. (1 <sup>st</sup> half)	17th. c.-18th. c.	MuF/b8, RoF7, CeR1, fillets
345. S. 1824	1737	1737	None?
346. S. 1841	1715	1715	MuF/b8, CeF57, CeF2, fillets
347. S. 1856 R	1662	1662	MuA/b5, MuF/d25, fillets
348. S. 1871	18th. c?	18th. c.	MuF/a61, fillets
349. S. 1889 NL	18th. c. (1 <sup>st</sup> quarter)	1572	MuF/b8, CeF2, CeF42, fillets
350. S. 1890 NL	18th. c. (1 <sup>st</sup> quarter)	18th. c. (1st quarter)	MuF/b8, CeF2, CeF42, fillets
351. S. 1924	1737?	1737	Fillets
352. S. 1931	17th. c.?	17th	MuF/e8, RoF9,
353. S. 1939	17th. c.	17th. c.	CeF45
354. S. 1953	18th. c.	18th. c.	MuF/b4, CeR16, fillets
355. S. 1955	18th. c.	18th. c.	MuF/a61& fillets
356. S. 1963 E	1667?	1667	MuF/a7, MuF/a8, MuF/c41, MuF/d1, MuF/d7, MuG/a1, MuG/a4, fillets
357. S. 1966 NL	1778 (before of)	1711	MuF/b8, fillets
358. S. 1976 G	1655	1655	MuF/c1, MuA/b4, MuV4, C7
359. S. 1991 A	15th. c.-16th. c.(late-early?)	14th. c.-15th. c.	MuF/a68, MuA/b15, MuG/a19, C3?
360. S. 1996 R	1657	1657	MuA/b5, fillets
361. S. 2000	17th. c.?	17th. c.	MuF/a57, RoF34, RoG21, MuV13, fillets
362. S. 2002 CA	17th. c. (1 <sup>st</sup> half)	17th. c.?	MuF/d4, MuV4, CeR40, fillets
363. S. 2008	NK	17th. c.	None
364. S. 2013	17th. c.	17th. c.	CoF15, CeF37, fillets
365. S. 2014	17th. c.	17th. c.	One cornerpiece, 1 centrepiece, a trifolium tool, a tiny roll(?), fillets, all typical Islamic
366. S. 2021	18th. c. (1 <sup>st</sup> half)	18th. c.	MuF/b8, CeR16

Catalogue Num.	Date of Binding	Date of Text	Tools
367. S. 2029 NL	18th. c. (1 <sup>st</sup> quarter)	1628	CeF2, CeR16, fillets
368. S. 2048	17th. c. (3 <sup>rd</sup> quarter?)	16th. c.	MuF/e27, MuA/a10, Mua/c3, fillets
369. S. 2056 R	1660?	1660	MuF/d25(?), fillets
370. S. 2060	1686	1686	RoF48, CoF3, CeF5, MuF/15, fillets
371. S. 2062 E	1660?	1660	MuF/a7, MuF/a8, MuF/c7, MuF/c41, MuF/d1, MuF/d7, MuF/d36, MuG/a4, fillets
372. S. 2065	17th. c. (late?)	1629	MuF/a64, fillets
373. S. 2071	18th. c. (1 <sup>st</sup> half)	1697	MuF/d8, fillets
374. S. 2101 CR	1478?	1478	MuF/a62, MuF/c38, MuF/d26, MuF/d28, MuF/d29, MuA/a14, MuA/c8, unclear concentric rings tool, fillets
375. S. 2105	17th. c. (3 <sup>rd</sup> quarter?)	17th. c. (before 1667)	MuF/a10, MuF/b11, CeR9, CeR10, CoF2, RoF19, fillets
376. S. 2111	1594	1594	MuF/c10, MuG/d8?, CeF53, fillets
377. S. 2123	18th. c.	1242	CoR23, CoR24, CoR25, CoR26, CeR45, CeR46, MuF/e9, like RoG10
378. S. 2136	1777	1777	RoG6, CeR49, fillets
379. S. 2137 NL	18th. c. (1 <sup>st</sup> quarter)	1672- 1719	CeF42, CeF47, fillets
380. S. 2140 R	1689	1689	MuF/d25, MuF/a60, RoF/41, fillets
381. S. 2151	18th. c.?	16th. c.	Only fillets
382. S. 2197	18th. c?	17th. c.-18th. c.	RoG6, MuF/b17, CeR41,
383. S. 2205	1648?	1648	MuF/c35, MuA/c3, rof41, faint lozenge tool, fillets
384. S. 2238	18th. c.	1720	None
385. S. 3135/22746	1733	1523	CeR6, MuV1, RoF7, fillets
386. S. A. 0013	15th. c. - 16th. c.	1222	MuA/b3, MuA/a5, fillets
387. S. A. 0014	17th. c.-18th. c?	17th. c.	RoF31, MuF/b17, MuF/c13, CeR41,
388. S. A. 0061 G	1641	1641	MuF/c1, MuG/b3, MuV4, C7
389. S. A. 0067	1537?	1537	None

Catalogue Num.	Date of Binding	Date of Text	Tools
390. S. A. 0068	15th. c. (and later repair)	14th. c.	MuF/c43, MuG/c3, CeF49, CoF19, fillets
391. S. A. 0072	14th. c. -15th. c. ?	897	G10, MuG/b2, MuG/c1, MuG/c2, MuG/a3, MuF/a18, MuF/a19, fillets
392. S. A. 0076 K	16th. c. (2 <sup>nd</sup> half)	13th. c.	MuF/a16, MuF/b10, MuF/d12, MuF/e13, MuF/c49, MuA/c3, RoF 35(?), C4
393. S. A. 0080 CR	1479	1479	None
394. S. A. 0089 A	15th c.-16th c.?(late-early)	1285	MuF/a71, MuF/d37, MuF/e25, MuA/b13, MuG/a6(?), C2
395. S. A. 0095	1277	1277	MuF/d15, and 2 more unclear
396. S. A. 0119	18th. c.?	1245	Fillets
397. S. A. 0158	18th. c. ?	1232	CeF41, CeR43, MuF/b17, RoF33
398. S. A. 0170 A	15th. c. -16th c. (late-early?)	1285	MuF/a71, MuF/c28, MuF/d22, MuF/e25, MuA/a11, MuA/b13, MuA/b18, MuA/c6, C2
399. S. A. 0270 G	1625 or 1639	1625 or 1639	MuF/c1, MuA/b4, MuV4, C7
400. S. A. 0325 G	1639	1639	uF/c1, MuG/b3, MuV4, C7
401. S. A. 0334 A	15th. c. (late?)	1321	MuA/b13, MuV17, MuV 18, C3
402. S. A. 0337 G	1622	1622	MuF/c1, MuA/b4, MuV4, fillets
403. S. A. 0339 N	1736 (before of)	14th. c.	MuF/b8, fillets
404. S. A. 0340 A	16th. c. (1 <sup>st</sup> half?)	13th. c.	MuF/a71, MuF/e25, MuA/b17, MuA/c3, C2
405. S. A. 0344	15th- 16th. c (late-early?)	13th. c.	MuF/d37, MuF/a71(?), MuF/e25, MuA/b13, MuG/a6(?), RoG24
406. S. A. 0351 CA	1635-39	1635 & 13th c.	MuF/c6, MuF/e16, MuF/c17, RoF10, fillets
407. S. A. 0390	15th. c.- 16th. c. (late-early?)	1164	MuF/d37, MuF/a71(?), MuF/e25, MuA/b13, MuG/a6(?), RoG24
408. S. A. 0397	15th. c. - 16th. c. (late-early?)	1333	MuF/a71, MuF/e36, MuA/c9, C2 (?)
409. S. A. 0398	15th. c.- 16th. c. (late-early?)	1258	MuF/e36, fillets
410. S. A. 0403	15th. c. - 16th. c. (late-early?)	1258	MuF/a71, MuA/b13(?), MuV17, MuV18, fillets(?)
411. S. A. 0409 A	15th. c.- 16th. c. (late-early?)	13th. c.	MuF/a71, MuF/d22, MuF/e36, MuA/a11, MuA/c6, MuA/c9, C2
412. S. A. 0423 G	1626	1626	MuF/c1, MuG/b3, MuV4, C7
413. S. A. 0435	18th. c.	13th. c.	MuF/b8, fillets

<b>Catalogue Num.</b>	<b>Date of Binding</b>	<b>Date of Text</b>	<b>Tools</b>
414. S. A. 0452	17th. c. (1 <sup>st</sup> half)	12th, 13th , 16th.	MuV3, MuF/c30, fillets
415. S. A. 0565 G	17th. c. (1 <sup>st</sup> half)	1622	MuF/c1, MuA/b4, MuV4, C7
416. S. A. 0676 NL	18th. c. (1 <sup>st</sup> half?)	1607	MuF/a54, MuF/a55, MuF/b8, fillets
417. S. Ge. 0016	17th. c. (1st half?)	992	MuF/d10, MuA/b13(?), Mua/c3, creaser (?)
418. S. Sl. 0015	16th. c.- 17th. c.	1627	MuF/a8, MuF/c35, MuF/d35, MuG/a20, MuG/a2, creaser (?)
419. S. Sl. 0048	17th. c. - 18th. c.		Cor19, CoR20, CoR21, CoR22, CeF38, MuF/b24, MuF/b25, MuF/b23, RoF32,



## **Appendix 7**

## Index of the scribes of the manuscripts surveyed

Date of text	Catalogue Number	Scribe/s-Printer/s
864	S. Ge. 0032	Nk
892/893?	S. 0375	Nk
897	S. A. 0072	Nk
967	S. 0213	Eustathios the presbyter
977	S. Ge. 0047	Nk
978	S. Ge. 0046	Nk
987	S. Ge. 0031	Nk
992	S. Ge. 0016	Gabriel
1004	S. 0448	Leo [..]?
1007	I. 0046	Theophanis monk
1063 ca.	S. 0500	Nk
1121/1122 & late 13th c.	S. 0044	Nk
1127-1157/8 ca.	S. 0157	Nk
1150	S. 0339	Iosiph abbot
1164	S. A. 0390	NK
1222	S. A. 0013	Nk
1223	S. 1464	Nk
1232	S. A. 0158	Nk
1242	S. 2123	Theodoros Trichas
1244	S. 0201	Nk
1245	S. A. 0119	Nk
1258	S. A. 0398	Zouan of Demetrios of Ioannis of hamza
1258	S. A. 0403	Gregorios monk and deacon son of
1277	S. A. 0095	Nk
1285	S. A. 0170	Nk
1285	S. A. 0089	Nk
1292	S. 0670	Nk
1294	S. 0094	Arsenios archbishop
1306	S. A. 0386	Nk
1321	S. A. 0334	Arsenios
1333	S. A. 0397	Simeon Basam priest of Iosiph from Santnaia
1337/8	I. 0608	Nikolaos
1361	S. 1627	Nk
1371	S. 0408	Nk
1426	I. 0835	Nk
1429	S. 0968	Bartholomaios priest (Rossos)
1432	I. 0788	Methodios monk
1437	S. 1262	Gregorios Alliatas

<b>Date of text</b>	<b>Catalogue Number</b>	<b>Scribe/s-Printer/s</b>
1452	S. 0027	Markos Pavlopoulos(?)
1452	S. 0573	Manuel Trapezountios
1453	S. 0585	Nicholaos priest tou Paraskevas
1457	S. 0628	Georgios priest Tsagaropoulos
1464 ?	S. 1343	Nk
1465	S. 0574	Nikolaos Skouras
1465	S. 1554	Georgios Gregoropoulos
1469	S. 1234	Ioannis priest protopapas (Plousidianos)
1478	S. 2101	Mathaios Trapezountios
1479	S. A. 0080	Nk
1484	S. 0639	Nk
1488	I. 0785	Nk
1488?	S. 0070	Nk
1491	S. 1194	Aristoboulos Apostolis
1510	S. 0297	Nk
1510	S. 1611	Seraphim deacon?
1512/13	I. 0436	Hosios Theophilos
1513	I. 0279	Hosios Theophilos
1514	I. 0382	Dionisios Proigumenos
1514	I. 0834	Hosios Theophilos
1514/15	I. 1500	Hosios Theophilos
1516	I. 1590	Hosios Theophilos
1518	I. 0809	Hosios Theophilos
1520	S. 0663	Nk
1522	I. 1498	Hosios Theophilos
1522/23	I. 1591	Hosios Theophilos
1522/23	I. 1595	Hosios Theophilos
1523	I. 0581	Hosios Theophilos
1530	I. 1337	Dionisios proigumenos
1533	I. 0697	Dionisios proigumenos
1534	I. 0392	Dionisios proigumenos
1534/ 35	I. 0259	Pahomios Rousanos
1536	I. 0810	Theodoros Ariologas
1537	S. A. 0067	Ioakim Basam from Gaza
1537	I. 0795	Theodoros Ariologas
1537/38	I. 0260	Pahomios Rousanos
1538	I. 1589	Neophitos <i>hieromonk</i>
1538	I. 0528	Hosios Theophilos
1540	I. 0593	Pahomios Rousanos
1540	I. 1599	Neophitos <i>hieromonk</i>
1540	I. 1585	Neophitos <i>hieromonk</i>

<b>Date of text</b>	<b>Catalogue Number</b>	<b>Scribe/s-Printer/s</b>
1540	I. 0833	Hosios Theophilos
1541/2	I. 0519	Hosios Theophilos
1542	I. 0783	Hosios Theophilos
1544	I. 1588	Neophitos <i>hieromonk</i>
1544	S. 0117	Nk
1544	S. 1756	Paphnoutios
1557	I. 0672	Lavrentios
1560	I. 0427	Theoclitos <i>hieromonk</i> (a)
1564	S. 1336	Germanos <i>hieromonk</i>
1565	S. 0087	Hieromonk Nikephoros Nathanailou
1567	S. 1334	Makarios <i>hieromonk</i> from Crete
1572	S. 1889	Nk
1586	I. 0423	Daniel
1594	S. 2111	Leontios <i>hieromonk</i>
1600	I. 1496	Seraphim monk
1601	I. 0864	Ginos
1602	S. 1732	Makarios <i>hieromonk</i> Sinaitis
1603	I. 1508	Seraphim monk
1603	I. 1518	Seraphim monk
1604	I. 1529	Seraphim monk
1606/7	I. 1552	Theoclitos <i>hieromonk</i> (a)
1607	S. A. 0676	Nk
1609	S. 1695	Ioakim <i>hieromonk</i> Sinaitis
1610	I. 0205	Avesalom <i>hieromonk</i>
1610	I. 0261	Daniel
1611	I. 1604	Daniel
1611-12	I. 0146	Avesalom <i>hieromonk</i>
1613	I. 1513	Seraphim monk
1613/14	I. 1524	Seraphim monk
1613/14	I. 1555	Seraphim monk
1615	I. 0257	Kirilos monk
1615/16	I. 1519	Loucas Bozau
1618	I. 0289	Ginos
1618	I. 1627	Kirilos monk
1620	S. 0074	Ieremias Sinaitis (Magafouris)
1621	I. 1557	Mathaios Mireon
1622	S. A. 0565	Simcon Basam
1622	S. A. 0565	Nk
1622	S. A. 0337	Simeon Basam
1622	I. 1533	Mathaios Mireon
1622	I. 0304	Stilianos priest from Ioannina
1622	I. 0299	Ginos

<b>Date of text</b>	<b>Catalogue Number</b>	<b>Scribe/s-Printer/s</b>
1622 (April)	I. 0724	Avesalom <i>hieromonk</i>
1623	I. 1122	Cosmas (not Macedon)
1624/5	I. 0911	Antonios Ksiropotaminos
1625	I. 0458	Kirilos monk
1625 or 1639	S. A. 0270	Simeon Basam
1626	S. A. 0423	Simeon Basam
1627	I. 0256	Kirilos monk
1627	S. Sl. 0015	Nk
1628	S. 2029	Philotheos <i>hieromonk</i>
1629	S. 2065	Nk
1634	I. 1530	Iakovos archiereas
1634	S. 0078	Ieremias Sinaitis (Magafouris)
1635 & 13th c.	S. A. 0351	Simeon Basam
1636 (September)	I. 0862	Avesalom <i>hieromonk</i>
1637	MBP. 12(ΒΧφ 8)	Anthimos <i>hieromonk</i> from Ioannina
1638	I. 0856	Anthimos <i>hieromonk</i> from Ioannina
1638	S. 0069	Anthimos <i>hieromonk</i> from Ioannina
1638	I. 1619	Antonios <i>hieromonk</i> (Ksiropotaminos?)
1639	I. 0395	Ginos
1639	S. A. 0325	Nk
1639 & 16th - 17th c.	I. 0904	Theoclitos <i>hieromonk</i> [c]
1639/40	I. 0530	Antonios Ksiropotaminos
1640 (September)	I. 1624	Avesalom <i>hieromonk</i>
1641	I. 1514	Anthimos <i>hieromonk</i> from Ioannina
1641	I. 1527	Anthimos <i>hieromonk</i> from Ioannina
1641	S. A. 0061	Simeon Basam
1642	I. 0393	Simeon <i>hieromonk</i> & Papasophronios
1642	I. 0473	Simeon <i>hieromonk</i> & Papasophronios
1643 (September)	I. 1615	Avesalom <i>hieromonk</i>
1643?	I. 1532	Anthimos <i>hieromonk</i> from Ioannina
1643?	S. 1630	Nk
1645/7	I. 1626	Mathaios Mireon / Theodosios
1647	I. 1605	Antonios <i>hieromonk</i> Ksiropotaminos
1648	S. 0091	Mathaios
1648	S. 2205	Nk
1650	I. 1622	Theoclitos <i>hieromonk</i> (a)
1652	S. 0433	Mathaios <i>hieromonk</i>
1653	S. 0426	Mathaios <i>hieromonk</i>
1654	I. 0625	Antonios Ksiropotaminos
1654	S. 1046	Neophitos <i>hieromonk</i>
1654	S. 0076	Mathaios tlipathis
1654	S. 0077	Mathaios <i>hieromonk</i>

<b>Date of text</b>	<b>Catalogue Number</b>	<b>Scribe/s-Printer/s</b>
1655	S. 1976	Iosiph hieromonk
1657	S. 1996	Gerasimos <i>hieromonk</i>
1659	S. 0089	Mathaios anaksios <i>hieromonk</i>
1660	S. 2056	Mathaios & Ioannikios
1660	S. 1814	Mathaios
1660	S. 2062	Mathaios
1662	S. 1856	Leontios monk
1663	I. 0401	Cosmas Macedon
1664	S. 0080	Mathaios
1665	S. 1297	Dimitrios Ioannou
1665	I. 0501	Theoclitos <i>hieromonk</i> (b)
1666	S. 0678	Mathaios tlipathis
1666/7 (?)	I. 0712	Antonios (Ksiropotaminos?)
1667	S. 1963	Gregorios
1670	I. 0991	Kosmas Macedon
1671 (before)	I. 1112	Nathanail metropolitan from Crete
1672- 1719	S. 2137	Ioannikios Mitilineos
1674	I. 1150	Cosmas Macedon
1674	I. 1200	Cosmas Macedon
1675	I. 1611	Theoclitos <i>hieromonk</i> (b)
1677	I. 0755	Cosmas Macedon
1679	I. 0564	Cosmas Macedon
1679	I. 1226	Cosmas Macedon
1679	I. 1531	Cosmas Macedon
1680	I. 1141	Cosmas Macedon
1680 ca	I. 0980	Cosmas Macedon (Thesis)
1680 ca.	I. 0979	Cosmas Macedon (Thesis)
1680 ca.	I. 0978	Cosmas Macedon (Thesis)
1682	I. 0927	Theoclitos <i>hieromonk</i> (b)
1682	I. 1074	Cosmas Macedon
1684	S. 1759	Galaktion
1684	I. 0402	Agapios Iviritis <i>hieromonk</i>
1685	I. 0644	Iosiph from Sinopi
1685	I. 1522	Agapios <i>hieromonk</i>
1685?	S. 1047	Maximos <i>hieromonk</i>
1686	I. 1048	Cosmas Macedon
1686	S. 2060	Theoclitos
1686	I. 0970	Cosmas Macedon
1689	S. 1469	Cosmas ek ton Iviron (Macedon?)
1689	S. 2140	Nk
1690	I. 0267	Iosiph from Sinopi
1690	S. 1478	Cosmas Macedon

<b>Date of text</b>	<b>Catalogue Number</b>	<b>Scribe/s-Printer/s</b>
1691	S. 1246	Nektarios <i>hieromonk</i> from Cyprus
1692	Skiti I. 4	Iosiph from Sinopi (partly)
1692	I. 0569	Iosiph from Sinopi
1692	I. 1183	Cosmas Macedon (Thesis)
1692/4	Skiti I. 1	Iosiph from Sinopi
1695	S. 1595	Athanasios <i>hieromonk</i> from Naousa
1696	I. 0422	Agapios <i>hieromonk</i> from Veroia
1696	I. 0586	Iosiph from Sinopi
1697	S. 2071	Silvestros & Anastasios
1697 - 1707	I. 0583	Iosiph from Sinopi
1698	I. 0434	Theoclitos <i>hieromonk</i> (b)
1700 ca	I. 0411	Iosiph from Sinopi
1700 ca.	I. 0252	Iosiph from Sinopi
1702	I. 1656	Agapios <i>hieromonk</i>
1702	S. 1136	Christophoros <i>hieromonk</i> from Sopiki
1706	S. 1518	Nikephoros Glikis
1706	I. 0600	Iosiph from Sinopi
1707	I. 0584	Iosiph from Sinopi
1709	Skiti I. 3	Iosiph from Sinopi
1711	S. 1966	Ioannikios from Crete
1715	S. 1841	Nk
1717	I. 1631	Agapios <i>hieromonk</i>
1720	S. 2238	Ioannikios from Lesvos
1722	I. 0858	Agapios Iviritis <i>hieromonk</i>
1722	I. 1358	Avimelech Iviritis ek Zakinthou
1737	S. 1824	Pagratios from Cyprus
1737	I. 0971	Ignatios from Skopelos
1737	S. 1924	Pagratios from Cyprous
1755	I. 1010	Theoclitos <i>hieromonk</i> [c]
1762	I. 0983	Theoclitos <i>hieromonk</i> [c]
1775 (before)	I. 1110	Nk
1777	S. 2136	Zacharias
9th. c.	S. 0033	Nk
9th. c.	S. 0030	Nk
10th. c.	S. 0356	Nk
10th. c.- 11th. c.	S. 0420	Nk
10th. c.-11th. c.	S. 0361	Nk
11th c.	S 0379	NK
11th. c.	S. 0520	Nk
11th. c.-12th. c.	S. 0175	Nk
11th. c.-12th. c.	S. 0173	Nk

12th, 13th , 16th. c.-17th.? c.	S. A. 0452	Nk
12th. c.	S. 0061	Nk
12th. c. (1st half)	S. 0237	Nk
12th. c. (2nd half) & 15th c.	S. 0216	Nk
12th. c.-13th. c.	S. 0043	Nk
12th. c.-13th. c.	S. 0014	Nk
13th c.	I. 0005	Nk
13th. c.	S. A. 0344	Arsenios
13th. c.	S. A. 0409	Ioannis tou Douka from Antioch
13th. c.	S. A. 0340	Ephraim from Tripoli
13th. c.	S. 0178	Nk
13th. c.	I. 0258	Nk
13th. c.	S. A. 0076	Nk
13th. c.	S. A. 0435	Nk
14th c.	MBII 25	Efraim
14th. c.	S. 0202	Nk
14th. c.	S. A. 0068	Nk
14th. c.	S. A. 0339	Nk
14th. c.	S. 1629	Nk
14th. c.	I. 0673	Nk
14th. c.	S. 1207	Nk
14th. c. - 15th. c.	S. 0931	Nk
14th. c. -15th. c.	S. 1991	Nk
14th. c.& 1525 circa	I. 0042	Hosios Theophilos
14th. c.-15th. c.	S. 0046	Nk
15th. c.	S. 0629	Nk
15th. c.	I. 0506	Nk
15th. c.	S. 0747	Nk
15th. c.	S. 0619	Nk
15th. c.	S. 0634	Nk
15th. c.	S 0425	Nk
15th. c.	S. 0808	Nk
15th. c.	S. 0403	Nk
15th. c.	I. 0359	Theoclitos from Magoula
15th. c.	S. 0615	Nk
15th. c.	S. 0112	Nk
15th. c.	S. 0269	Nk
15th. c.	I. 0801	Nk
15th. c.	S. 0804	Nk
15th. c.	S. 0788	Nk
15th. c.	S. 0649	Nk
15th. c.	S. 1247	Nk
15th. c.	I. 0511	Nk



15th. c. (1st half)?	S. 0764	Nk
15th. c. (1st half?)	S. 0165	Hio[..]
15th. c.-16th. c.	S. 0604	Nk
15th. c.-16th. c.	S. 0803	Nk
15th. c.-16th. c.	S. 1768	Nk
15th. c.-16th. c.	S. 0109	Nk
15th. c.-16th. c.	S. 0605	Nikodemos & Priest Petros
15th. c.-16th. c. (before 1523 )	S. 1110	Ioakim
15th. c.-16th. c.?	S. 1162	Nk
16 th. c. (1st half)	I. 1501	Hosios Theophilos
16th c. (1st half)	I. 0503	Dionisios Proigumenos
16th c. (1st half)	I. 0678	Hosios Theophilos
16th c. (1st quarter)	I. 0513	Hosios Theophilos
16th c. (1st third)	I. 0691	Dionisios Proigumenos
16th c. (2nd quarter)	I. 0193	Pahomios Rousanos
16th. c. (2nd quarter)	I. 0754	Pahomios Rousanos
16th c. (2nd quarter)	I. 1101	Pahomios Rousanos?
16th c. (2nd quarter)	I. 0591	Pahomios Rousanos
16th. c.	I. 0907	Nk
16th. c.	S. 0763	Nk
16th. c.	S. 1793	Nk
16th. c.	I. 0388	Theophanis Eleavoukos
16th. c.	S. 1171	Nk
16th. c.	S. 0203	Nk
16th. c.	S. 2048	Nk
16th. c.	I. 0818	Nk
16th. c.	S. 0120	Nk
16th. c.	S. 0975	Nk
16th. c.	I. 0424	Daniel
16th. c.	I. 0147	Theophanis Eleavoukos
16th. c.	I. 0782	Nk
16th. c.	S. 1618	Nikolaos Kolivitzas (?)
16th. c.	S. 2151	Nk
16th. c.	S. 1400	Mk
16th. c.	S. 0075	Nk
16th. c. (1st half)	S. 0806	Nk
16th. c. (1st half)	I. 0837	Nikephoros & Hosios Theofilos
16th. c. (2nd century)	I. 0790	Theodoros Ariologas
16th. c. (2nd half)	I. 0278	Theoclitos hieromonk (a)
16th. c. (2nd quarter)	I. 0787	Theodoros Ariologas
16th. c. (2nd quarter)	I. 0786	Theodoros Ariologas
16th. c. (2nd quarter)	I. 0880	Pahomios Rousanos
16th. c. (2nd quarter) partly	I. 0899	Pahomios Rousanos(ff. 1-95)

16th. c. (3rd quarter)	I. 1499	Laurentios
16th. c. (3rd quarter)	I. 1505	Laurentios
16th. c. (3rd quarter)	I. 1506	Laurentios
16th. c. (4th quarter)	I. 0582	Iosiph from Sinopi (partly)
16th. c. (end)	I. 1503	Laurentios
16th. c. (middle)	S. 0985	Nk
16th. c.- 17th. c.	S. 1048	Nk
16th. c.-17th. c.	S. 1691	Nk
16th. c.-17th. c.	I. 1211	Nk
17th	S. 1931	Neophitos <i>hieromonk</i> Cretan?
17th c.	S. 0108	Nk
17th c.	I. 1209	Nk
17th c. ( middle)	I. 0993	Cosmas Macedon?
17th c. (1st half)	I. 1447	Avesalom <i>hieromonk</i>
17th c. (1st quarter)	I. 1613	Nk
17th c. (3rd quarter)	I. 1080	Nk
17th c. (4rth quarter)	I. 0493	Iosiph from Sinopi
17th c. (4th quarter)	I. 1116	Nk
17th c. (4th quarter) partly	I. 1448	Iosif from Sinopi (partly)
17th c. (middle)	I. 1525	Anthimos <i>hieromonk</i> from Ioannina
17th. c.	S 0710	Nk
17th. c.	S. 1701	Nk
17th. c.	S. 0475	Nk
17th. c.	I. 1052	Nk
17th. c.	S. 2216	Anthimos <i>hierodeacon</i>
17th. c.	I. 1081	Nk
17th. c.	I. 0297	Nk
17th. c.	I. 0628	Theoclitos <i>hieromonk</i> (d)
17th. c.	I. 0522	Daniel
17th. c.	S. 1461	Nk
17th. c.	S. A. 0014	Nk
17th. c.	S. 2000	Nk
17th. c.	I. 1140	Nk
17th. c.	I. 1078	Nk
17th. c.	S. 1159	Nk
17th. c.	I. 1221	Nk
17th. c.	I. 1053	Nk
17th. c.	I. 0491	Theoclitos <i>hieromonk</i> (a)
17th. c.	I. 1197	Nk
17th. c.	I. 0762	Theoclitos <i>hieromonk</i> (a)
17th. c.	I. 0838	Theoclitos <i>hieromonk</i> (a)
17th. c.	I. 0928	Nk
17th. c.	S. 1939	Nk

17th. c.	I. 1174	Cosmas Macedon
17th. c.	S. 1558	Nk
17th. c.	S. 0088	Nk
17th. c.	I. 1168	Nk
17th. c.	S. 1509	Nk
17th. c.	S. 2013	Nk
17th. c.	S. 2008	Nk
17th. c.	I. 1166	Nk
17th. c.	S. 1683	Nk
17th. c.	I. 1092	Nk
17th. c.	I. 1176	Nk
17th. c.	S. 2014	Nk
17th. c.	S. 1496	Nk
17th. c. (1st half)	S. 0072	Ieremias Sinaitis (Magafouris)
17th. c. (1st half)	I. 0839	Daniel
17th. c. (1st quarter)	I. 1497	Iosiph Savaitis
17th. c. (1st quarter)	I. 1215	Nk
17th. c. (2nd half)	I. 1614	Daniel
17th. c. (early)	I. 1618	Daniel
17th. c. (early?)	I. 1173	Nk
17th. c. ?(Kamil dates it in the 18th)	S. 2002	Nk
17th. c.(before 1667)	S. 2105	Nk
17th. c.?	MBP. 13(Bχφ 11)	Mpalasios priest
17th. c.?	S. 1174	Nk
17th. c.-18th. c.	S. 1819	Nk
17th. c.-18th. c.	I. 0231	Avimelech Iviritis from Zakynthos
17th. c.-18th. c.	S. 2197	Nk
18th c.	S. 1689	Nk
18th c.	I. 1368	Avimelech Iviritis from Zakynthos
18th. c. (1st quarter)	S. 1890	Nk
18th. c.	S. 1542	Ioannis protopsaltis?
18th. c.	S. 1370	Nk
18th. c.	I. 1135	Nk
18th. c.	No num	Nk
18th. c.	I. 0173	Nk
18th. c.	I. 1058	Nk
18th. c.	I. 1073	Nk
18th. c.	S. 1468	Nk
18th. c.	S. 1418	Nk
18th. c.	S. 0443	Nk
18th. c.	S. 1421	Timotheos
18th. c.	S. 1676	Nk
18th. c.	S. 1955	Nk

18th. c.	S. 1953	Gerasimos Bizantios?
18th. c.	S. 1871	Neophitos <i>hieromonk</i>
18th. c.	I. 1085	Nk
18th. c.	S. 2021	N.k (same as 1841)
18th. c. (1st half)	I. 0967	Damaskinos Iviritis ?
18th. c. (early)	I. 1308	Iosiph from Sinopi
18th. c?	I. 0307	Ginos

## **Appendix 8**

**Diakonima:** the specific responsibility or work of a monk in the context of the every day life in a monastrey.

**Dodekaorto:** The representation of the 12 major feasts of the year.

**Hexameros** Book of the Old Testament.

**Hierodeacon:** a monk who is at the same time a deacon.

**Hieromonk:** a monk who is at the same time a priest, that is, higher up in the hierarchy than a deacon or hierodeacon.

**Hosios :** amonk or hieromonk who has given signs of sanctification after death.

**Ipotaktikos:** a monk or hieromonk with an older monk as a mentor.

**Idiorithmic:** a monastic system where every monk makes hi own schedule and meet together only for the liturgical and ecclesiastical needs of the community.

**Kathisma, kathismata :** the place where hermits live.

**Katholicon:** the main, central church of a monastery.

**Kalivi, kalives:** another word for *kathisma*.

**Keli, kelia:** another word for *kathisma*.

**Megalo Schema:** the procedure through which a novice becomes a monk.

**Menaion / Menaia:** book containing the lives of saints which have their feast day in in one of the 12 months.

**Metochion :** a dependency of a monastery often far away from the it.

**Mesi;** a storage room inside the monastery where all sort of things, including food, was stored.

**Panagia:** The Virgin Mary.

**Patericon:** book containing the lives of saints.

**Pentikostarion:** part of a *sticherarion* used in the period between the Easter Sunday to the All Saints Sunday.

**Pneumatikos:** a priest with the capacity of confessor.

**Portaitisa :** a specific icon of the Virgin preserved in the Iviron monastery.

**Proigoumenos :** the second after the abbot in the hierarchy of a monastery.

**Prosmonarios :** monk charged with the welcoming of guests.

**Silitourgia:** a liturgy where more than one priests are reciting.

**Skevophilakion:** the Treasury

**Skiti, skites:** an independent small idiorithmic monastic settlement for only a few monks. Normally more *skites* found close one to the other will have a common church where the gather every Sunday for the liturgy.

**Synodikon:** the ceremonial room of a monastery where important events take place like the reception of important visitors, the celebration of the monastery etc.

**Taktikon:** catalogue of political and ecclesiastical officials.

**Tetraevangelion:** book containing the three synoptic Gospels (Luke, Mark, Mathew) and the Gospel of John.

**Thikaras:** book containing hymns and blessings.

**Tipicon:** the rules under which a monastic brotherhood is organised.

**Triodion:** part of a *sticherarion* used in the period between the Sunday of the Phariser to Easter Sunday.

**Vrefokratousa:** an iconographical type of the Virgin holding infant Christ in her hands.

## **Appendix 9**

**Adam 1923-1924:** P. Adam, Die griechische Einbandkunst und das fruchchristliche Buch', *Archiv für Buchbinderei*, 1923 (pp. 89-91), 1924 (21-4, 31-3, 41-3, 51-3, 61-4, 78-80, 82-4, 97-9).

**Angelou 1965:** A. Angelou. 'J.D.Carlyle's Journal of Mount Athos (1801)', *O Epavιστής* 3 (1965) 50, pp. 33-71.

**Astruc 1982:** Ch. Astruc, 'Isidore de Thessalonique et la relieure à monogramme du Parisinus graecus 1192', *Revue Francaise d' Histoire du Livre* 36 (1982), pp. 261-272.

**Atsalos 1976:** B. Atsalos, 'Sur quelques termes relatifs a la reliure des manuscrits grecs', *Actes du XIV Congres International des Etudes Byzantines*, Bucuresti 1976, pp. 43-49.

- 2000: B. Atsalos, 'Termes Byzantines relatifs a la decoration des manuscrits Grecs', *I Manoscritti Greci tra riflessione e dibattito. Atti del V Colloquio Internazionale di paleografia Greca (Cremona, 4-10 ottobre 1998)*, Edizioni Gonnelli, Firenze 2000, pp. 446-511.

**Baras et al. 1978:** E. Baras, J.Irigoin, J. Vezin, 'Le relieur byzantine', *Le relieur medievale. Trois conférences d' initiation*, Paris 1978, pp. 23-54.

**Benešević 1911 :** V. N. Benešević, *Catalogus Codicum mancriptorum graecorum qui in Monastreio Sanctae Catharinae in Monte Sina asservantur, tomus I.: Codices manuscripti notabiliores bibliothecae Sinaitici ejescueMetochii Cahirensis, at archimandrita Porphyrio (Unspenskiio) descripti*, Petropoli 1911.

- 1917 : *Catalogus Codicum Mancriptorum Graecorum qui in Monastreio Sanctae Catharinae in Monte Sina asservatur, Tomus III. 1. Codicus numeris 1224-2150 signati*, Petrograd 1917.

**Blaser 1982:** L. Blaser, 'The development of endpapers', *Guild of Book Workers Journal* , volume XXXII, Number 1, Spring 1994, pp.1-29.

**Bosch et al. 1981:** G. Bosch, J. Carswell, G. Petherbridge, *Islamic Bindings and Bookmaking. A catalogue of an exhibition*, The Oriental Institute, May 18-August 18, The University of Chicago, 1981.

**Bourbon 1998.** F. Bourbon, *Petra and the Holy Land. Lithographs of David Roberts*, R.A. Edizioni White Star, Vercelli 1998.

**Briquet 1907:** C.M. Briquet, *Les filigranes. Dictionnaire historique des marques du papier des leur apparition vers 1282 jusqu'en 1600*, volumes I-IV, Paris 1907.

**Buchthal and Belting 1978:** H. Buchthal and H. Belting, *Patronage in thirteenth-century Constantinople. An atelier of late Byzantine book Illumination and Calligraphy*, Dumbarton Oaks, Washington, 1978.

*Byzantine books and bookmen*, Dumbarton Oaks Symposium, April 1971, Dumbarton Oaks, Washington, 1975

**Canart 1990-1991:** P. Canart, 'Reliure et codicology. Perspectives de la recherche', *La legatura dei libri antichi tra conoscenza, valorizzazione e tutela Convegno internazionale, Parma, 16-18 novembre 1989, Bolletino dell' Istituto Centrale Patologia del Libro* 44-45 (1990-1991), pp. 55-73.

**P. Canart et al 1991 :** P. Canart, D. Grosdidier de Matons , Ph. Hoffmann, 'L' analyse technique des reliures byzantines et la determination de leur origine géographique (Constantinople, Crete, Chypre, Grece)', *Scritture, Libri e Testi nelle Aree Provinciali di Bisanzio*, (Erice 18-25 Settembre 1988), Spoleto, Centro Italiano di Studi sull' Alto Medioevo, 1991, pp. 751-768, and plates I-VIIIb.



**Cataldi 1986:** P. Cataldi, 'Un gruppo di manoscritti greci del primo quarto del XVI secolo appartenenti alla collezione di Filippo Sauli', *Codices Manuscripti* 12 (1986), pp. 93-124.

**Cavallo 1981:** G. Cavallo, 'Il libro come oggetto d'uso nel mondo Bizantino', *XVI Internationaler Byzantinistenkongress (Wien, 4-9. Oktober 1981)*, Verlag Der Osterreichischen Akademie der Wissenschaften, Wien 1981. pp. 395-423.

**Clark 1953:** K. Clark. 'Exploring the manuscripts of Sinai and Jerusalem', *The Biblical Archeologist*, vol, XVI No 2, (May 1953), pp. 22-43.

- **1960:** 'Research Resources in St. Catherine's Monastery in Sinai', in *Trudy XXV-go mezdunarodnogo Kongressa Vostokovedon*. Moskva 9-16 Augusta 1960, Moskau 1960. pp. 517-522.

**Curzon 1849 :** R. Curzon, *Visits to the Monasteries in the Levant*, London 1849 916, eighth edition 1916.

**Dahari 2000,** U. Dahari, *Monastic settlements in South Sinai in the Byzantine period. The archaeological remains*. Israel Antiquities Authority, Jerusalem 2000.

**De Carthage à Kairouan 1983:** *De Carthage à Kairoua, 2000 ans d'art et d'histoire en Tunisie, Mesees du Petit palais de la Ville de Paris 20 octobre 1982-27 fevrier 1983, Paris 1983.*

**De Gregorio 1993:** G. De Gregorio, 'Per uno studio della cultura scritta a Creta sotto il Dominio Veneziano: I codici Greco-Latini del secolo XI', *Scrittura e Civiltà* 17 (1993), pp. 103-201.

**De Marinis 1960:** Tamaro De Marinis, *La legatura artistica in Italia nei secoli XV e XVI, Notizie ed elenchi, vols 1,2,3*, Fratelli Alinari / Istituto di edizioni artistiche, Firenze 1960.

**De Matons 1991:** D. Grosdidier. de Matons, 'Nouvelles perspectives de recherche sur la reliure byzantine', *Paleografia e codicologia greca. Atti del II Colloquio internazionale* (Berlino-Wolfenbüttel, 17-21 Ottobre 1983), Alessandria : Edizioni dell' Orso, vol. 1, 1991.

**De Matons et al 1998:** D. Grosdidier de Matons, and Ph. Hoffmann, 'La couture des reliures byzantine', *Rescherches des codicologie compare. La composition du codex au Moyen Age, en Orient et en Occident*, Paris: Presses de l'Ecole normale superieure, 1998, pp. 205-254.

- **1990-1991 :** De Matons D. G, and Ph. Hoffman, 'Un groupe de reliures byzantine provenant du monastere athonite de Kastamonitou', *La legatura dei libri antichi tra conoscenza, valorizzazione e tutela* (Convegno internazionale, Parma, 16-18 novembre 1989), Bolletino dell' Istituto Centrale patologia del Libro. 44-45 (1990-1991), pp. 327-402.

**Doresse 1961 :** J. Doresse, 'Les reliures des manuscrits gnostiques decouverts a Khonoboskion', *Revue d' Egyptologie*, 13 (1961), pp. 27-49.

**Droulia 1982:** 'Les foyers de culture en Grece pendant la domination ottomane: le cas des bibliotheques', *To Βιβλίο στις προβιομηχανικές κοινωνίες*, Κέντρο Νεοελληνικών Ερευνών, Εθνικό Κέντρο Ερευνών, Αθήνα 1982, pp. 189-206.

**Džurova 2000:** 'La synthèse Slavo-Byzantine dans les manuscrits Grecs dits de 'Grand luxe', créés en Valachie et en Moldavie aux XVIe-XVIIe siècles', *Η Ελληνική γραφή κατά τους 15<sup>ο</sup> και 16<sup>ο</sup> αιώνα*, Εθνικό Ίδρυμα Ερευνών, Ινστιτούτο Βυζαντινών Ερευνών, Διεθνή Συμπόσια 7, Αθήνα 2000. pp. 499-521.

**Emery 1994:** I. Emery, *The primary structures of fabrics. An illustrated classification*, Washington: Washington, The textile museum, 1966, reprinted in 1994.

**Ettinghausen 1958:** R. Ettinghausen, 'Near eastern book covers and their influence on European bindings. A report on the exhibition "History of

Bookbinding'' at the Baltimore Museum of Art', 1957-58, *Ars orientalis*, 3, pp. 113-131.

**Federici and Houlis 1988:** C. Federici & K. Houlis, *Legature Bizantine Vaticane*, Istituto Centrale Patologia del Libro 1988.

**Foot 1979:** M. M. Foot, 'Influences from the Netherlands on bookbinding in England during the late fifteenth and early sixteenth centuries', *Actes du Xie Congrès International de Bibliophilie*, Brussels, 1979, pp. 39-64.

-1997: M. Foot, *The History of bookbinding as a mirror to society*, The Panizzi Lectures, 1997, The British Library, 1998.

**Galavaris 1984:** G. Galavaris, ' "Sinaitic" Manuscripts in the time of the Arabs', *Δελτίο της Ελληνικής Αρχαιολογικής Εταιρείας*, IB', (1984), Αθήνα 1986.

- 2000: 'The ornamentation of 15<sup>th</sup>/16<sup>th</sup> century "Sinaitic" manuscripts', *Η Ελληνική γραφή κατά τους 15<sup>ο</sup> και 16<sup>ο</sup> αιώνες*, Εθνικό Ίδρυμα Ερευνών, Ινστιτούτο Βυζαντινών Ερευνών, Διεθνή Συμπόσια 7, Αθήνα 2000. pp. 443-463.

**Gamillscheg 1981:** E. Gamillscheg, 'Die Handschriftenliste des Johannes Chortasmenos im Oxon. Aed. Chr. 56', *Codices Manuscripti* 7 (1981), Heft 2, pp. 52-56.

**Gardthausen 1886:** V. Gardthausen, *Catalogus Codicum, Graecorum, Sinaiticorum*, Oxonii, 1886.

**Garitte 1956:** G. Garitte, *Catalogue des Manuscrits Georgiens littéraires du Mont Sinai*, Louvain 1956.

**Geanakoplos 1958:** D. J. Geanakoplos, 'A Byzantine looks at the renaissance. The attitude of Michael Apostolis toward the rise of Italy to cultural eminence', *Greek and Byzantine Studies* 1. 1958.

-1962: *Greek Scholars in Venice. Studies in the dissemination of Greek learning from Byzantium to Western Europe*, Cambridge Mass. 1962.

**Codoñer 1996 :** J. S. Codoñer, 'Le Diplomacia del libro en Bizancio', *Scrittura e Civiltà* , XX, 1996, pp. 11-187.

**Gratziou 1982:** O. Gratziou, *Die Dekorierten handschriften des schreibers Matthaios von Myra (1596-1624)*, Athens 1982.

**Greenfield and Hille 1990,** J. Greenfield and J. Hille, *Hendbands. How to work them*. Newcastle, DE, Oak knoll Books, 1990.

**Gunter 2000,** Q. Guner (ed) *Vom Kettenbuch zur Collage, Bucheinbände des 15. bis 20. Jahrhunderts aus den Sammlungen der Universitäts- und Stadtbibliothek Köln*, Köln 2002.

**Haldane 1983:** D. Haldane, *Islamic bokkbindings in the Victoria and Albert museum*, London, 1983.

**Harlfinger et al 1983:** D. Harlfinger, D. R. Reinsch, J. A. M. Sonderkamp, G. Prato, *Specimina Sinaitica. Die datierten griechischen Handschriften des Katharinen-Kloster auf dem Berge Sinai. 9 bis 12. Jahrhundert*, Dietrich Reimer Verlag, Berlin 1983.

**Hobson 1979:** A. Hobson, 'Bindings à la Grecque', *X International Congress of Bibliophiles* (Athens, 30 September - 6 October 1977), Athens 1979, pp. 59-60.

- 1989: 'Humanists and Bookbinders. The origins and diffusion of the humanistic bookbinding 1459-1559 with a census of historiated plaquette and medallion bindings of the renaissance', Cambridge Univeristy Press, 1989.

**Hobson 1988:** G. D. Hobson, 'Some early bindings and binder's tools', *Studies in the history of bookbinding*, The Pindar Press, London 1988, pp. 1-54.

**Hoffmann 1942:** Ph. Hoffmann, 'La bibliotecha scientifica del monastreo di San Francesco a Candia nel medio evo', *Orientalia Christiana Periodica* 8 (1942), pp. 317-360.

- **1982:** 'Reliures Crétoises et Vénitiennes Provenant de la Bibliothèque de Francesco Maturanzio et Conservées a Pérouse', *Mélange de l' Ecole Française de Rome, Moyen Age- Temps Moderns*, 94 (1982.), pp. 729-757.

- **1983:** 'La Collection de Manuscrits Grecs de Francesco Maturanzio, erudite Perugin (ca. 1443-1518)', *Mélange de l' Ecole Française de Rome, Moyen Age- Temps Moderns*, 95, (1983), pp. 89-147.

- **1985:** 'Une nouvelle relieure Byzantine au monogramme des paléologues (Ambrosianus M 46 sup. =GR. 512)', *Scriptorium* 39, 2 (1985), pp. 274-281.

-**1992:** 'L' art de la reliure à Byzance sous les Paléologues', *Byzance. L'art byzantine dans les collections publiques française (Musée du Louvre, 3 novembre 1992-1<sup>er</sup> février 1993)*, Bibliothèque Nationale, 1992, pp. 467-471.

**Holton 1991:** D. Holton (ed), *Literature and Society – Renaissance Crete*, Cambridge 1991.

**Houlis 1993:** K. Houlis, 'A research on structural elements of Byzantine bookbindings', *Ancient and Medieval Book materials and Techniques, (Erice, 18-25 September 1992)*, Studi e Testi 357, Citta del Vaticano, Biblioteca Apostolica Vaticana, 1993.

**Houlis et al. 1999:** K. Houlis, S. Sampaziotou, G. Boudalis, 'The Restoration of manuscripts in Byzantine and post-Byzantine Greece', *International Conference on Conservation and Restoration of Archival and Library material (Erice, 22-29 April 1996)*, Palumbo Editore, 1999, pp. 517- 536.

**Hutterell 1998:** A. Hutterell, The Latin East, in *The New Cambridge Medieval History*, vol. VII, ch. 31, Cambridge 1998.

**Icone Arabes. Art Chretien du levant.** Exposition presente a l' Institut du Monde Arabe du 6 mai au 17 août 2003. Editions Gregoriens, Paris 2003.

**Irigoin 1961-62:** J. Irigoin, 'Un groupe de reliures Crétoises, XV siecle, Πεπραγμένα του Α' Διεθνούς Κρητολογικού Συνεδρίου, Κρητικά Χρονικά, τόμος ΙΕ'-ΙΣΤ', τεύχος ΙΙ, 1961-62, pp. 102-112.

**Kamil 1970:** M. Kamil, *Catalogue of all the manuscripts in the Monastery of St. Catherine on Mount Sinai*, Otto Harrassowitz, Wiesbaden 1970.

**Klepikov 1961:** S.A. Klepikov, 'Russian Bookbinding from the 11th to the Middle of the 17th century', *The Book Collector* 10 (1961), pp. 408-422.

**Laffitte and Bars 1999:** M.-P. Laffitte et F. le Bars, *Reliures royales de la Renaissance. La librairie de Fontainebleau (1544-1570)*, Seuil-Paris, 1999.

**Le Tranchefiles brodées 1989:** *Le Tranchefiles brodées. Etude historique et technique.* Paris, Bibliothèque Nationale, 1989.

**Lindsay 2001:** J. Lindsay, 'The Edfu collection of Coptic books', *The New Bookbinder*, volume 21, 2001, pages 31-51.

**Maniaci 1993:** M. Maniaci, 'Che fare del proprio corpus? I. 'Costituzione e descrizione di una popolazione di libri a fini statistici', *Gazette du Livre Medieval*, 22, 1993, pp. 27-37

II. 'L' osservazione sperimentale e l' interpretazione dei risultati', *Gazette du Livre Medieval*, 23, 1993, pp. 18-27.

**Manoussakas and Staikos 1987:** M. Manoussakas & K. Staikos, *The publishing activity of the Greeks during the Italian Renaissance (1469-1523)*, Athens 1987.

**Marian de la Croix 2002:** Mère Agnès-Mariam de la Croix. 'Christian Arabic Art between the 13th and 20th centuries', *The splendor of Christian orient*, Frankfurt 2002.

**Mioni 1977:** E. Mioni, *Introduzione alla Paleografia Greca*, Padova 1973, and Greek translation *MIET*, Athens 1977.

**Muthesius 1997:** A. Muthesius, *Byzantine silk weaving, AD 400 to 1200*, Verlag Fassbaenedr, Vienna 1997.

**Needham 1979:** *Twelve centuries of bookbindings 400-1600*, New York: the Pierpont Morgan Library, Oxford University Press 1979.

**Nersessian et al. 2002:** V. Nersessian, C. Pitrovano (eds) *Treasures from the Arc, 1700 years of Armenian Christian Art*. British Library, London 2002.

**ODB:** *The Oxford Dictionary of Byzantium*, A. P. Kazhdan (editor in chief, A.-M. Talbot (executive editor), A. Cutler (editor for art history), T. E. Gregory (editor for archaeology and historical geography), N. P. Sevchenko (associate editor), volumes 1, 2, 3, Oxford University Press, 1991.

**Petherbridge 1991:** G. Petherbridge, 'Sewing structures and materials: a study in the examination and documentations of Byzantine and post-Byzantine bookbindings', in *Paleographia e Codicologia Greca*, Atti del II Colloquio Internazionale (Berlino – Wolfenbüttel) 17-21 Ottobre 1983, Alesandria 1991, pp. 363-408.

**Pickwood 1991:** N. Pickwood, 'Italian and French sixteenth-century bookbindings', *Gazette of the Grolier Club*, 43, 1991, pp. 55-80.

- 1994: 'Onward and Downward: How Binders Coped with the printing press before 1800', *A millennium of the Book. Production, Design and Illustration in manuscript and Print. 900-1900*, Manchester: St Paul's Bibliographies/Delaware: Oak Knoll Press 1994, pp. 61-106.

- 1995: 'The interpretation of bookbinding structure. An examination of sixteenth-century bindings in the Ramey collection in the Pierpont Morgan Library', *The Library*, sixth series 17 (1995), pp. 209-249.

**Pitrovano 2001:** C. Pitrovano 2001, *Arte e Sacro Mistero. Tesori dal museo Russo di San Petrobourgo*. Electa 2001.

**Prato and Sonderkamp 1985:** G. Prato-J. A.M. Sonderkamp, 'Libro, Testo, Miniature: il caso del cod. Sinait. Gr. 2123', *Scrittura e Civiltà* 9 (1985), pp. 309-323.

**Rabi and Tanindi 1993:** J. Raby and Z. Tanindi, *Turkish bookbinding in the 15<sup>th</sup> century. The foundation of an Ottoman court style*, Azimuth editions on behalf of L' Association Internationale de Bibliophilie, London 1993.

**Rabino 1935:** M. H. L. Rabino, *Le monastère de Sainte Catherine (Mont Sinai), Souvenirs Epigraphiques des Anciens paliers*, Le Caire 1935.

**Regemorter 1953:** B. van Regemorter, 'La relieure des manuscrits grecs et l' Egypte', *Bibliothèque Patriarchale (Institut d' Etude Orientales), Publications, 2, Tome commémoratif du Millenaire de la Bibliothèque patriarchale d' Alexanrie*, 62, Alexandria 1953, pp. 62-66.

- 1954: 'La relieure des manuscrits grecs', *Scriptorium* 8 (1954), pp. 3-23.

- 1961: *Some Oriental Bindings in the Chester Beatty Library*, Dublin, Hodges Figgis & Co Ltd. 1961.

- 1967: 'La reliure byzantine', *Revue Belge d' archeologie et d' histoire de l'art*, 36 (1967), pp. 247-312.

**Roberts and Etherington 1982 :** M. T. Roberts and D. Etherington, *Bookbinding and the Conservation of Books. A dictionary of descriptive terminology*. Washington, 1982.

**Schunke 1964:** Il. Schunke, 'Venezianische Einbände "Alla greca" aus der Meerman-Phillips-Sammlung in Berlin', *Gutenberg Jahrbuch*, (1964), pp. 375-383.

**Sinai, Byzantium, Russia, 2000:** *Sinai, Byzantium, Russia*, The St Catherine's Foundation, London, The State Hermitage Museum, St Petersburg, 2000.

**Sonderkamp 1991:** J. A.M. Sonderkamp, 'Zu einigen Einbänden in der Bibliothek des Katharinenklosters' *Pelografia e codicologia greca. Atti del II Colloquio internazionale* (Berlino-Wolfenbuttel, 17-21 Ottobre 1983), Alessandria: Edizioni dell' Orso, vol. 1, 1991, pp. 431-439, 213-220.

**Spitzmuller 1982/83:** P. Spitzmuller, 'A trial terminology for describing sewing through the fold', *The Paper Conservator*, volume 7, 1982/83, pp. 44-46.

**Soucek 1998:** P. Soucek. 'Byzantium and the Islamic East', *The Glory of Byzantium. Art and culture of the middle Byzantine era. AD 843-1261*. Metropolitan Museum of Art, 11 March - 6 July 1997. The Metropolitan Museum of Art. pp. 402-411.

**Szirmai 1996:** J. Szirmai, 'The Archeology of Bookbinding and Book Restoration', *The New Bookbinder*, vol. 18, 1998. Reprinted from *Quarendo* 26/2 1996.

- 1999: *The Archeology of the medieval bookbinding*, Ashgate, 1999.

**Tarnanidis 1988:** I. C. Tarnanidis, *The Slavonic manuscripts discovered in 1975 at the St. Catherine's monastery in mount Sinai*, Thessaloniki 1988.

**The Splendor of Christian Orient 2002:** *The Splendor of Christian Orient*, Iconen Museum 24 November 2002- 2 March 2003. Frankfurt am Main, 2002.

**Thornton 1998:** P. Thornton, *Form & Decoration. Innovation in the decorative arts 1470-1870*, Weidenfeld & Nicholson, London 1998.

**Velmans 2001:** T. Velmans, 'La couverture de l' Evangelie dit de Morozov et l' évolution de la reliure byzantine', *Byzance, Les Slaves et l' Occident*, The Pindar Press, London 2001, 405.

**Weitzman and Galavaris 1990:** K. Weitzman and G. Galavaris, *The Illuminated Greek Manuscripts, I: from the ninth to the twelfth century*. Princeton University Press, New York, 1990.

**Willoughby 1939:** H. R. Willoughby, 'Greek rebinding colophons in Chicago manuscripts', *Annales de l' Institut Kondakov* 2 (1939), pp. 21-32.

-1940: 'A contribution to knowledge of Greek monastic bookbindings', *The Elizabeth Day McCormic Apocalypse*, volume 1, Chicago 1940, pp. 66-70.

**Wittek 1953:** M. Wittek, 'Pour un étude du scriptorium de Michel Apostoles et consorts', *Scriptorium* 7 (1953). pp. 290-297.

**Woodcock and Robinson 1988 :** Woodcock and Robinson, *The Oxford Guide to Heraldry*, Oxford University Press, 1988.

**Αμάντος 1928:** Κ. Αμάντος, *Σιναϊτικά μνημεία ανέκδοτα, Ελληνικά, Παράρτημα 1*, 1928.

-1953: Κ. Αμάντος, *Σύντομος Ιστορία της Ιεράς Μονής του Σινά, Ελληνικά, Παράρτημα 3*, 1953.

**Ασπρά 1992:** Μ. Ασπρά- Βαρδαβάκη: *Οι μικρογραφίες του Ακάθιστου στον κώδικα Garrett 13, Princeton*, Αθήνα 1992.

**Άτσαλος 1997:** Β. Άτσαλος, 'Τα Ελληνικά χειρόγραφα του Αγίου Όρους', *Θησαυροί του Αγίου Όρους*, Θεσσαλονίκη 1997, pp. 583-588.

**Αθανασιάδης 1994:** Χ. Αθανασιάδης, 'Συναγωγή βιβλιοδετικών διακοσμητικών θεμάτων σε Ελληνικά χειρόγραφα και παλαιά έντυπα', *Μορφωτικό*

*Ίδρυμα Εθνικής Τράπεζας, Δελτίο του Ιστορικού και Παλαιογραφικού Αρχείου, στ' 1988-1992, Αθήνα 1994, pp. 647-714.*

**Γαλάβαρης, 1994:** Γ. Γαλάβαρης 'Βιβλιογραφικές ενασχολήσεις του επισκόπου του Σινά Ασένιου τον 13<sup>ο</sup> αιώνα', *Σύμμεικτα*, τόμος 9, μέρος Α', Εθνικό Ίδρυμα Ερευνών, Κέντρο Βυζαντινών Ερευνών, Αθήνα 1994. pp. 133-139.

-2000: *Ιερά Μονή Ιβήρων, Εικονογραφημένα Χειρόγραφα, Άγιον Όρος 2000.*

**Γκράτζιου 2000:** Ό. Γκράτζιου 'Επαγγελματίες γραφείς και περιστασιακοί μικρογράφοι κατά τον 16<sup>ο</sup> αιώνα', *Η Ελληνική γραφή κατά τους 15<sup>ο</sup> και 16<sup>ο</sup> αιώνες*, Εθνικό Ίδρυμα Ερευνών, Ινστιτούτο Βυζαντινών Ερευνών, Διεθνή Συμπόσια 7, Αθήνα 2000. pp. 466-483.

**Δαμιανός 1998:** Δαμιανού, Αρχιεπισκόπου Σινά, Φαράν και Ραιθώ, 'Το ιστορικόν της ευρέσεως των νέων ευρημάτων του Σινά', *Τα Νέα Ευρήματα*, Υπουργείο Πολιτισμού – Ίδρυμα Όρους Σινά, Αθήνα 1998. pp. 1-24.

**Δημαράς 1982:** Κ. Θ. Δημαράς, 'Το δυτικό βιβλίο στον Ελληνικό χώρο', *Το Βιβλίο στις προβιομηχανικές κοινωνίες*, Κέντρο Νεοελληνικών Ερευνών, Εθνικό Κέντρο Ερευνών, Αθήνα 1982, pp. 169-188.

**Ευστρατιάδης 1918:** Σ. Ευστρατιάδου, *Κατάλογος των εν τη μονή Βλατάδων (Τσαούς Μοναστήρι) αποικείμενων κωδικών*. Εν Θεσσαλονίκη Τύποις Παντελή και Ν. Ξενοφωντίδου, 1918.

**Hunger 1995:** H. Hunger, *Ο κόσμος του Βυζαντινού βιβλίου. Γραφή και ανάγνωση στο Βυζάντιο*, Ινστιτούτο του Βιβλίου – Μ. Καρδαμίτσα, Αθήνα 1995.

**Θεολόγος 1998:** Μοναχός Θεολόγος Ιβηρίτης, 'Ιστορικό περίγραμμα της συλλογής των Ελληνικών χειρογράφων της Ιεράς Μονής Ιβήρων', *Ιερά Μονή Ιβήρων Κατάλογος Ελληνικών Χειρογράφων*, τόμος Α', Άγιον Όρος 1998, pp. 237-254.

**Θησαυροί:** Σ. Μ. Πελεκανίδου, Π. Κ. Χρήστου, Χ. Μαυροπούλου-Τσιούμη, Σ. Ν. Καδά, *Οι Θησαυροί του Αγίου Όρους. Εικονογραφημένα χειρόγραφα, παραστάσεις, επίτιτλα, αρχικά γράμματα*, volumes Α, Β, Γ, Δ, Αθήνα 1973, 1975, 1979, 1991.

**Reynolds and Wilson 1989:** L. D. Reynolds & N. G. Wilson, *Αντιγραφείς και Φιλολόγοι. Το ιστορικό της παράδοσης των κλασικών κειμένων*, ΜΙΕΤ, Αθήνα 1989.

**Καδάς 1984:** Σωτήρη Καδά, *Το Άγιον Όρος, τα μοναστήρια και οι θησαυροί του*, Εκδοτική Αθηνών, Αθήνα 1984.

**Λάμπρος, 1900:** Σπυρίδωνος Π. Λάμπρου, *Κατάλογος των εν ταις βιβλιοθήκας του Αγίου Όρους Ελληνικών κωδικών*, τόμος Β', Κανταβριγία της Αγγλίας 1900.

**Λέγγας 1998:** Μπ. Λέγγας, 'Μοναστηριακή βιβλιοδεσία. Τα εργαστήρια της μονής Δουσίκου, Αγίου Όρους και Πατριαρχείου Ιεροσολύμων', *Τέχνη της Βιβλιοδεσίας*, Καθημερινή Επτά Ημέρες, 8 Φεβρουαρίου 1998, pp. 11-13

-1999: Μπ. Λέγγας, *Το βιβλιοδετείο 'Ο Άθως'*, Βιβλιοαμφιάστης, 1999, pp. 207-233.

**Λιάτα 1996:** Ε. Δ. Λιάτα, *Φλωρία δεκατέσσερα στέγουν γρόσια σαράντα. Η κυκλοφορία των νομισμάτων στον Ελληνικό χώρο, 15<sup>ο</sup>-19<sup>ο</sup> αιώνες*. Κέντρο Νεοελληνικών Ερευνών, Εθνικό ίδρυμα Ερευνών 58, Αθήνα 1996.

**Μαμαλάκης Ι.Π.** 'Το Άγιον Όρος (Άθως) δια μέσου των αιώνων', Μακεδονική Βιβλιοθήκη 33, Εταιρεία Μακεδονικών Σπουδών, Θεσσαλονίκη 1971.

**Μαραβά and Τουφεξή 1978, 1985:** Α. Μαραβά-Χατζηνικολάου, Χ. Τουφεξή-Πάσχου, 'Κατάλογος μικρογραφιών Βυζαντινών χειρογράφων της Εθνικής Βιβλιοθήκης της Ελλάδος', τόμοι Α', Β'. Ακαδημία Αθηνών, Athens 1978, 1985.

**Μπαλλιάν 1998:** Α. Μπαλλιάν, 'Αργυρά καλύμματα Ευαγγελίων. Εικονογραφικά θέματα, τεχνικές. Επιδράσεις και εξέλιξη στην βυζαντινή και

μεταβυζαντινή περίοδο', *Τέχνη της Βιβλιοδεσίας*, Καθημερινή Επτά Ημέρες, 8 Φεβρουαρίου 1998, pp. 9-10.

**Μπουδαλής 2004:** Γ. Ν. Μπουδαλής, 'Ισλαμικές σταχώσεις και η επίδρασή τους στις Ελληνικές σταχώσεις της μεταβυζαντινής εποχής', Βιβλιοαμφιάστης, τόμος 2, Due to publication in summer 2004.

**Νικολόπουλος 1998:** Π.Γ. Νικολόπουλος, 'Συνοπτική καταγραφή των νέων ευρημάτων Ελληνικών χειρογράφων του Σινά', *Τα Νέα Ευρήματα*, Υπουργείο Πολιτισμού – Ίδρυμα Όρους Σινά, Αθήνα 1998, pp.71-288.

**Ντιγκμπασάνη 1993:** Ιερομόναχου Σιναίτου Δ. Ντιγκμπασάνη, 'Η Σιναιτική βιβλιοθήκη', *Θεολογία*, 1992, τεύχος Γ', pp. 555-583, τεύχος Δ', pp. 826-847, 1993, τεύχος Α'-Β', pp. 255-282.

**Οικονομίδης 1997:** Ν. Οικονομίδης, 'Η Ιστορία του Αγίου Όρους κατά την Βυζαντινή περίοδο', *Θησαυροί του Αγίου Όρους*, Θεσσαλονίκη 1997, pp. 4-9.

**Παπαστράτου 1986:** Παπαστράτου Δ. *Χάρτινες εικόνες, Ορθόδοξα θρησκευτικά χαρακτηριστικά 1665-1899*, τόμοι 1, 2, Αθήνα 1986.

**Πατρινέλης, 1961:** Χ. Γ. Πατρινέλη, 'Έλληνες κωδικογράφοι των χρόνων της Αναγεννήσεως', *Επετηρίς του Μεσαιωνικού Αρχείου* 8/9 (1958/9), Αθήνα 1961, pp. 53-124.

**Πολίτης 1957:** Λ. Πολίτης, 'Αγιορείτες βιβλιογράφοι του 16<sup>ου</sup> αιώνα', *Ελληνικά* 15, Θεσσαλονίκη 1957, Reprinted in L. Politis, *Paléographie et littérature Byzantine et néo-grecque, Recueil d' études*, pp. 355-384, Variorum reprints, London 1975.

-1961: *Οδηγός Καταλόγου Χειρογράφων*, Γενικόν Συμβούλιον Βιβλιοθηκών της Ελλάδος 17, Αθήνα 1961.

-1979: *Το Βιβλιογραφικό Εργαστήριο και η βιβλιοθήκη της Μονής Προδρόμου Σερρών*, Αθήνα 1979.

**Πολίτης and Πολίτη, 1994:** Λίνος Πολίτης & Μαρία Πολίτη, 'Βιβλιογράφοι 17<sup>ου</sup> –18<sup>ου</sup> αιώνας: Συνοπτική καταγραφή', *Δελτίο του Ιστορικού και Παλαιογραφικού Αρχείου* 6 (1988-1992), *MIET*, Αθήνα 1994, pp. 313-646.

**Ραπτάρης 1869:** Ι. Μ. Ραπτάρη, *Εντυπώσεις περιηγήσεων εις Άθωνα, Επτάλοφος* 6 (1869), pp. 206-207.

**Reynolds and Wilson 1989:** L. D. Reynolds & N. G. Wilson, *Αντιγραφείς και φιλόλογοι. Το ιστορικό της παράδοσης των κλασικών κειμένων*, [Ελληνική μετάφραση από το Αγγλικό πρωτότυπο Ν. Μ. Παναγιωτάκης, Μορφωτικό Ίδρυμα Εθνικής Τράπεζας, Αθήνα 1989, pp. 269-84

**Σαθά 1872:** Κ. Σαθά, 'Κατάλογος των εν Άθωνι Βιβλιοθηκών', *Μεσαιωνική Βιβλιοθήκη*, том 1, Αθήνα 1872

**Σιναϊτικόν Ημερολόγιον 1977:** *Σιναϊτικόν Ημερολόγιον μετά ιστορικών και άλλων πληροφοριακών στοιχείων*, έκδοσις Ιεράς Μονής Σινά, 1977.

**Σκλαβενίτης 1982:** Ε. Τ. Σκλαβενίτης, 'Η δυσπιστία στο έντυπο βιβλίο και η παράλληλη χρήση του χειρογράφου', *Το Βιβλίο στις προβιομηχανικές κοινωνίες*, Κέντρο Νεοελληνικών Ερευνών, Εθνικό Κέντρο Ερευνών, Αθήνα 1982, pp. 283-293.

**Σπυριδάκης 1962:** Γ. Κ. Σπυριδάκης, 'Ο δικέφαλος αετός ίδια ως σύμβολον ή ως θέμα κοσμήσεως κατά την Βυζαντινή και Μεταβυζαντινήν μέχρι των νεωτέρων χρόνων περίοδον', *Επετηρίς Εταιρείας Βυζαντινών Σπουδών*, τόμοι ΛΘ'- Μ', Θεσσαλονίκη 1962.

**Στάθης 1993:** Γρ. Θ. Στάθη, *Τα χειρόγραφα Βυζαντινής μουσικής, Αγιον Όρος. Κατάλογος περιγραφικός των χειρόγραφων κωδίκων Βυζαντινής μουσικής των αποκειμένων εν ταις βιβλιοθήκες των Ιερών μονών και σκητών του Αγίου Όρου*, Τόμος Γ', Αθήνα 1993.