

PROJECTIVE SPACE



KENNETH WILDER

PROJECTIVE SPACE

Structuring a Beholder's Imaginative Response

Doctor of Philosophy
Awarded by University of the Arts London

March 2009

Abstract

The thesis explores the reciprocal relationship between an artwork and the space of its reception. It proposes a distinctive position on spatiality and the virtual. The thesis is submitted in two parts: a written thesis (Part One), and a documentation of my own art practice (Part Two).

The artwork that comprises the practice component is not that of a painter, and yet the sculptural installations I present allude to perspectival paintings. Utilising perspectival geometry, these site-responsive works engage the threshold between two and three-dimensional representation in a way whereby implicit and actual beholder's viewpoints are contrasted or fused.

The written thesis focuses on the reception of perspectival painting, rather than on my own artworks. Referencing analytical philosophical arguments on representational seeing, and the reception aesthetics of Wolfgang Kemp, it puts forward a distinctive position that contends that while the visual imagination does not define depiction, it plays a pivotal role in supplementing perception in works where the spectator attends to and/or imagines away the threshold separating the real and fictive realms. After Merleau-Ponty, I call such an imaginative engagement *seeing-with*, which describes a particular *use* to which painting is put. In providing a strongly felt pictorial depth, I argue that such an implied pictorial space incorporates the space between painting and spectator position.

I investigate two categories of works where such imagining facilitates a distinctive access to the picture's content: (i) paintings containing what Wollheim refers to as an 'internal spectator'; and (ii) paintings integrated into their architectural settings, where the internal onlooker is fused with the external spectator. I highlight differences afforded internal and external spectators: with the former, the viewer identifies with a spectator who already occupies an unrepresented extension of the 'virtual' space; with the latter, the beholder enters that part of the fictive world depicted as being *in front of* the picture surface, the work thus drawing the 'real' space of the spectator into its domain.

This distinction mirrors two distinct types of visualization: where a scene is imagined as *elsewhere*, and where it is situated, juxtaposed with an existing reality. Imagination provides a reciprocity that replicates the experience of our bodily situatedness, in that it structures our implied spatial access to the depicted scene. In establishing a bodily frame of reference, it draws upon nonconceptual content. The thesis tests the philosophical argument against specific paintings, including works that introduce a break from a situated relationship in order to depict the supernatural or the unconscious.



To the memory of my mother

Acknowledgments

I would like to thank my three supervisors, David Ryan, Dr Brendan Prendeville and Dr Laura Jacobus, for their kind and enthusiastic support, and for the high level of intellectual debate they have provided. I would also like to thank Professor Stephen Scrivener and the staff of the research office for the financial and administrative support I have been given as a member of academic staff at Chelsea College of Art and Design. Peter Stickland played an invaluable role in fostering my research interests in this territory. My PhD has benefited from fruitful discussions with fellow academic staff and research students, too numerous to mention. I would like to thank the invaluable technical input of Stefan Willis and Mick Stickland in constructing a number of the works. All the metal elements of my installations have been fabricated by my friend Michael Sanders, whose work is always of the highest quality. The computer drawings of the installations are by an outstanding former student of mine, Ge Fei Dong. I would finally like to thank my good friend Sharon McDuell for her perceptive comments on a draft version of the thesis.

During the time I have undertaken my PhD, I have lost my mother, a very close friend, Jayne Comins, and a valued work colleague, Shelagh Cluett. While I have dedicated this thesis to the memory of my mother, Jayne and Shelagh are both sorely missed.

Contents

Preface	11
Introduction	17

Part One

1. A Phenomenological Distinction?	35
2. The Case for an External Spectator	51
3. Seeing Depth and Nonconceptual Content	63
4. Two Modes of Situated Relationship	79
5. <i>Las Meninas</i>	111
6. A Displacement Device	125
7. On Projection and Sublimation	153
Conclusion	169
Notes	183
References and Bibliography	209
List of Illustrations	217
List of Published and Exhibited Works	221

Part Two

Catalogue of Artworks + DVD	223
-----------------------------	-----

Preface

This thesis constitutes a heterogeneous mix of contemporary art practice, analytic philosophy of art and perspectival painting. Given that I studied architecture, rather than fine art, philosophy or art history, the content of the research will perhaps be surprising. While I now practice as an artist, the concerns that underlie my art practice nevertheless reflect an ongoing dialogue with architectural space. And it is this long-standing concern with the relationship between an artwork and the space of its reception that is key to understanding the seemingly diverse nature of the material presented.

The artwork that forms the practice component of my submission is not that of a painter, and yet the works themselves allude to painting. More particularly, they allude to a certain kind of painting: perspectival works implying the presence of a spectator as part of their content. A philosophical consideration of the beholding of such works will constitute the larger part of the written thesis. My interest lies less with such paintings' narrative or religious content, and more with how this content is structured by the implied spatial relationship between different parts of the painting and the viewer. Of course, this spatial relationship is not, in itself, 'real', in that painting presents two perspectives, that of the spectator and that of the implied spatial scene; as the Italian philosopher Paolo Spinicci has suggested, the figurative space of painting does not readily integrate itself with real space (2008).¹ While the structuring of a work's reception is a function that is already *implicit* to the work of art, the experience of pictorial depth on which it rests is in itself dependent upon an imaginative engagement on the part of the spectator - one that is prompted and licensed by the work, but requires the beholder's imaginative consent. It is a concern with the spatial implications of this structuring role for imagination that distinguishes the theoretical position the thesis proposes.

After Maurice Merleau-Ponty, I shall call such a projective engagement *seeing-with*, a seeing according to the painting (1993c, p. 126). I do not consider such an experience of pictorial space as necessarily internal to the virtual world painting presents: I make a distinctive case that certain works imply (and, more strongly, anticipate) the presence of an

external spectator, the beholder of the picture. In so doing, I will draw distinctions between the imaginative engagements I argue are afforded internal and external spectators.

As will already be apparent, my account therefore allocates considerable importance to the role of imagination in 'pictorial seeing', a term I take to have a wider remit than that of depiction. Nevertheless, I argue that the projection of the third dimension into the two-dimensional marked surface is ancillary to an experienced resemblance: it is not a necessary condition for depiction, but a particular *use* to which pictures are put. It is also independent from any attention to the nature of the marked surface: how a painting utilizes the medium of paint.² And yet, as Malcolm Budd notes, it is only with imagination that we gain a 'vivid' experience of pictorial depth, providing the work in question supports such an engagement (2004, p. 392). This vivid experience of pictorial depth is essential for the richer experience of pictorial perception considered in this thesis, in paintings implying a reciprocity between the work of art and its beholder. Two things follow, which tend not to be fully acknowledged in philosophical accounts of depiction. Firstly, pictorial depth is generally experienced as being relative not to a picture's surface, but to a point of view, and therefore, I would argue, includes an experience of the space between the virtual space of the painting and the implied but unrepresented spectator position (whether or not this position is 'occupied'). This inclusion of an awareness of the space *between* the represented scene and what Robert Hopkins terms the depiction point (2004, pp. 150-151) is essential for the kind of reciprocity I am proposing is a factor of works completed by the presence of a viewer, where the external beholder identifies with the implied, but absent, spectator. Secondly, different works construct this relationship in different ways, dependent upon whether the implied spectator is conceived as *internal* to the fictive space of painting, occupying an implied extension of the represented scene, or whether the work activates the 'real' space of the beholder, in a way whereby internal and external spectators either fuse, *or* (in some instances) clash. The latter engagements are not the full kinetic activation of sculpture in-the-round, but invoke a kind of bodily readiness: itself dependent upon a special role for the imagination (both visual and bodily) in drawing an awareness of the surrounding architecture into the internal *imaginative* experience such paintings afford.

Given that the writing will focus on a philosophical position informed by examples largely drawn from Renaissance and Dutch genre painting, I feel some obligation to say something here about the relationship between the writing and the practice component catalogued in Part Two of the thesis. A connection to a very different kind of painting is self-evident in the smaller of two groups of works that I present. This is a series of artworks that, to reverse the trajectory of Michael Fried's disapproving comment on Donald Judd's predilection for a certain kind of painting, comprise *objects on the verge of becoming paintings*.³ The viewer adopts a stance that initially replicates the position taken up by a spectator in

front of a certain kind of Minimalist painting or sculpture. The pieces comprise continuous folded forms (in effect, unbroken 'frames'), their outward manifestations registering as discrete blocks of monochrome colour. A more intimate stance is required to view narrow stepped passages that lead to spaces beyond. These concealed internal spaces exclude the external beholder, and can only be accessed through the imagination. The spectator must peer into these works' hidden recesses in order to fully experience the artwork, and it is the establishing of two very different modes of viewing that connects such works to the philosophical argument presented by the thesis.

I have referenced perspectival painting, particularly (though not exclusively) Italian Renaissance works, in a second body of work that integrates video projection and sculptural object. The connection here with painting is not intended as an illustrative one. Rather, what I take from painting is a shared concern with the conditions of spectatorship, and with notions of coexistent or duplicated realities. I problematize the perspectival structure of film in relation to three-dimensional sculptural objects. These installations address the relationship between the representational space of the moving image (filmic space) and the 'space of reception', the reality of the architectural space in which the projected image is seen. By juxtaposing filmic and 'real' space, the works both draw attention to while simultaneously negating the presence of the screen as two-dimensional surface and projected reality.

My artwork is thus fundamental to the submission, and replicates many of the concerns addressed in the text with respect to perspectival paintings. The art practice is in itself considered a legitimate mode of 'theoretical' enquiry, in that it materializes ways of thinking about space: the theoretical component is embedded within text *and* art practice, and the interaction between these parallel but interrelated elements is central to my concerns. Nevertheless, I find myself at odds with the common premise that contemporary art practice favours the conceptual or hermeneutic condition of the object rather than the direct experiential encounter. I contest the supposition that there needs to be such a polarization of the conceptual and the experiential. Artworks that explore the phenomenology of their reception can legitimately be seen as examples of practices that also engage particular ways of thinking; after all, as Richard Wollheim has noted, both perception and imagination are highly permeable to thought.

It is also important for me that many of the theoretical propositions underlying the research into painting have genuinely emerged out of parallel concerns arising from my art practice. The sculptural installations I construct do not 'illustrate' a preconceived theoretical position, and while here framed by the thesis, are decidedly not to be experienced solely in this light. The work engages many concerns that fall outside of the remit of the thesis itself.⁴ While such works are undoubtedly part of the research process (and within the context of the thesis must be considered as such), they are intended to be experienced *as* artworks,

rather than *as* research.

As such, I have chosen not to write at great length about the works themselves, nor to 'interpret' them for the benefit of the reader. I begin each chapter with a short front-piece, a description of one of the sculptural installations catalogued in Part Two. Each piece is chosen for its relevance to the theoretical concerns of the particular chapter. Art practice and text are thus juxtaposed. But, by and large, I leave it to the reader to make the necessary connections. I do not reflect, at great length, on the practice itself. Rather, the artwork is left to stand on its own terms – a deliberate choice, as I am dubious about the strategy of placing one's own work at the very centre of the written thesis.

The thesis is presented in two parts: a written thesis (Part One), and a comprehensive documentation of my own art practice (Part Two). The latter includes an attached DVD documenting work incorporating the moving image.

In the Introduction, I set out my methodological position, referencing reception aesthetics, phenomenology and (crucially) analytic philosophy. In particular, I distinguish my position from semiotic accounts of representational seeing, where, to quote Wollheim, 'the grasp of representational meaning is fundamentally an interpretative, not a perceptual, activity' (2001a, p. 15). While broadly supportive of aspects of Wollheim's alternative notion of a *criticism as retrieval*, I agree that its 'archaeological' emphasis has a particular blind spot in that, by and large, it excludes the work's reception from contributing to its meaning-bearing properties. The role imagination plays in an extended account of depiction can, I contend, make good something of this deficiency.

The philosophical investigation into the respective spatial relationships implied between artwork and beholder will form much of the substance of the first three chapters. In Chapter One, I address Merleau-Ponty's dilemma of '*where* the painting is' (1993c, p. 126), relating this to the issue of painting's double-aspect, where we see both a marked surface and an absent scene. In considering how the absent object enters into the experience, I engage with a number of analytic theories of depiction. I go on to argue a particular role for the imagination in an expanded account of representational seeing, a role in negotiating painting's two perspectives – that of the absent scene, and that of an external beholder.

In Chapter Two, I question the assumption that painting always presents a self-contained world, isolated from the external beholder. While the vast majority of representational works have no implied spectator (other than generally being depicted from a more, or less, specific point of view), the issue of self-containment has particular relevance to works where the presence of a beholder forms part of the work's content. While acknowledging that some works do, indeed, engage a spectator internal to painting's virtual world, I use Masaccio's *Trinity* to claim that in other paintings, integrated into their architectural settings, the *internal* onlooker is fused with the *external* spectator. Here the

imaginative engagement is situated. I highlight differences afforded internal and external spectators: with the former, the viewer identifies with a spectator who already occupies an unrepresented extension of the 'virtual' space; with the latter, the beholder enters that part of the fictive world depicted as being *in front of* the picture surface, the work thus drawing the 'real' space of the spectator into its domain. This is particularly relevant to a type of fictive chapel that uses 'illusory' means not to fool the eye, as in *trompe l'oeil* works, but as an imaginative prop, where different parts of the painting are allocated different levels of painted reality.

In Chapter Three, I reference Merleau-Ponty's situated perception; in particular, I extend Sean Kelly's (2005) interpretation of what he terms Merleau-Ponty's 'bodily readiness' to the role imagination plays in painting. This is the way the viewer is "'potentially lodged in" the other points of view on the object' (p. 100), a nonconceptual situatedness that is analogous to Merleau-Ponty's account of the body's motor intentionality. I draw parallels between such a proposition and Christopher Peacocke's notion of a *positioned scenario*, used in relation to 'nonconceptual representational contents' (1992, ch. 3). Referencing Hopkins's chapter on visualization in *Picture, Image and Experience* (1998, ch. 7), I argue that it is the shared perspectival nature of ordinary vision, visualization and *seeing-in* that affords such an imagined experience of depth in painting.

Chapter Four then applies the philosophical position in a more concrete way to particular paintings, referencing the rich tradition of art historical writing on spectatorship. I test my philosophical position against individual artworks and their art historical literature. I investigate works implying either external or internal spectators, and works that construct a tension between the two modes of viewing. In so doing, I critically reference a number of prominent art historical accounts that address a work's reception as part of its semantic content.

In Chapter Five, I consider Velázquez's *Las Meninas*, a painting sufficiently complex in its relation between artwork and spectator to demand its own chapter. This is a work that blurs the boundaries between the modes of engagement considered in Chapter Four: while it presents possible identifications with figures represented *within* the scene, it also references our physical arrival in front of the work. I argue that it might be considered as 'two' distinct works, a fictional portrait of the royal couple and the very group portrait that confronts us.

The preceding chapters prepare the ground for Chapter Six, the subject of which is closest to the original question the thesis set out to address. Here I maintain that early Renaissance painters faced a real problem as to how to depict visionary states within the unified space of perspective. Such *unreal* states demand further differentiation from the implied continuity of the fictional space lying behind (and sometimes in front of) the picture plane. I identify a number of works which incorporate a *break* or *gap* from a situated

relationship between the pictorial space and the space of the viewer in order to represent the supernatural: a displacement that is nevertheless predicated for its experiential impact upon the suggestion of a spatial continuity between pictorial space and viewer. I argue that an imaginative engagement is essential for the effectiveness of such a device. I then develop the argument in relation to one strategy applicable to smaller works, where the implicit viewer is internal to the virtual world. I claim that a *doorsien*, a narrative device utilizing a secondary picture-within-a-picture, has the potential to be modified to psychological ends; with Vermeer, it is adapted as a means to materialize unconscious states of mind of a figure within the work.

In the final chapter I raise the question of how works depicting supernatural or unconscious states gain emotive content. In so doing, I critically evaluate Wollheim's theory of artistic expression. While acknowledging problems with Wollheim's account, I salvage elements of the theory to argue that certain works' aligning of structure to religious content can invoke the intimation of processes of projection, introjection and sublimation.

In the Conclusion, I ask whether the argument constructed in relation to the beholding of paintings might have relevance beyond the confines of perspectival painting. In so doing, I reference Postminimalist and expanded cinema practices from the late 1960s and 1970s. Sceptical of drawing too direct parallels, I nevertheless acknowledge a similar concern in terms of the drawing of architectural space into the experience of an artwork, and in constructing different degrees of spatiotemporal reality. But how does the engagement of a spectator differ when she is a literal rather than implied presence? I argue that the use of 'situated' video and film installations introduces elements of spatial and temporal reciprocity that draw the spectator into the work's content. Such works overlay time frames and juxtapose filmic and real space. These are devices that are similarly utilized by works presented in Part Two of the thesis.

Introduction

1.

In this thesis, I question the assumption that painting always presents a self-enclosed world, 'bracketed off' from real space. Or more accurately, I question the assumption that the imaginative *use* to which representational painting is put must necessarily imply such a split between fictive scene and embodied beholder. In so doing, I address distinctions and tensions between the different imaginative engagements which I argue are afforded paintings¹ implying an *internal* or *external* spectator: that is works where the beholder is considered as internal to the representational world of the artwork, against works that can be said to engage something of the 'real' space of an embodied spectator. Whereas with an internal spectator, the external beholder identifies with an implied spectator who is intrinsic to the essentially closed structure of the work, paintings implying a role for an external spectator (that is, where the physical presence of a viewer is *implicit* to the painting's content) engage the space of reception, drawing the surrounding architecture into the work's content. While this may not be the kinetic activation of the beholder's space that Susanne Langer (1953) insists is involved in the viewing of sculpture, the engagement such works imply nevertheless constitutes a special case demanding a particular role for imagination: such works are completed by the external presence of a spectator in such a way that the internal and external spectators *fuse*, in a way whereby the beholder draws an awareness of the work's architectural context into the imaginative engagement with the painting.

In both variations, the relations between artwork and viewer originate in, and are instantiated by, the work itself. With the former, the engagement with the painting has an independence from its place of viewing, the work's frame separating out a fragment of a prior reality; with the latter, the artwork addresses the boundary between the virtual space of the work and the beholder's location, so that the work *functions* more directly within what Wolfgang Kemp terms its 'conditions of access' (1994, p. 366).² Here, the frame is integrated into the painting's host architecture, but also into the fictional realm. But

it is important to note that such a relationship *does not replicate our experience of ordinary visual space*, in that this is an imaginary not illusory experience, regardless of the use of so-called 'illusory' devices. I am not therefore claiming that non-inferential control is present, precisely because distinctions between the painting's different levels of reality are fundamental to the work's meaning. This requires the beholder's imaginative consent.

As such, my theoretical context can legitimately be seen as falling within territory characterized by Kemp as the 'aesthetics of reception' (1998).³ As Kemp notes, a defining premise of reception aesthetics is that 'the function of beholding has already been incorporated into the work itself' (p. 181). It is a Hegelian premise with which I agree, in so far as it is taken to mean that a work structures and anticipates the reciprocal encounter between an implicit spectator and artwork.⁴ However, I am reluctant to be *too* narrowly bound by the theoretical concerns of *Rezeptionsästhetik*. My reservation stems from an unease with its interpretative bias, an over emphasis on the 'reading' of signs. Thus, Kemp argues that the aesthetics of reception 'has to discern the signs and means by which the work establishes contact with us' (p. 183). He has in mind something like the 'focusing' gesture of the maid in Nicolaes Maes's *The Eavesdropper* (fig. 1), part of the Collection of Harold Samuel, a painting that I will go on to argue creates a tension between rather than a merging of the engagements afforded an as yet unrealised notion of an internal spectator and the external viewer.

Now my disagreement with Kemp is not in the discernment of such signs in itself, but rather the uses to which the interpretation is put. The maid's overtly 'theatrical' gesture, where we are urged to be silent, might indeed be interpreted as an *indexical* sign,⁵ in that it reaches out from the fictional world of the painting to the world of the external beholder *as* audience (in much the same way as a character in a play might, as an aside, directly address the audience). The indexicality of the sign follows from its prepositional nature: it refers to an assumed viewer in a way that is analogous to what Charles S. Peirce describes as 'a situation relative to the observed, or assumed to be experientially known, place and attitude of the speaker relatively to that of the hearer' (1985, p. 16). Indeed, Peirce, contrary to the use to which he is frequently put, emphasises the *experiential* nature of such indexical directions. He argues that 'some indices are more or less detailed directions for what the hearer is to do in order to place himself in direct experiential or other connection with the thing meant' (p. 15). And this is precisely what Maes's gesture encourages the spectator to do.

I also accept that aspects of such an engagement are conventionalised. To use Kemp's terminology, such signs belong to the work's 'outer' rather than 'inner' apparatus (1998, p. 191), in that they are there to be interpreted by the spectator *of* the picture, the viewer standing before the work. Spinicci has similarly referred to what he terms the '*meta-iconic* message', in that the message is 'aimed at the spectator from the painting, in a gesture that



Fig. 1 Nicolaes Maes: *The Eavesdropper* (1655), Collection of Harold Samuel, London.

seems to invite the viewer to comment on the scene, rather than play a part in it' (2008). With Maes's work, our role in interpreting the maid's gesture is not that of a spectator as yet *internal* to the fictional world, a participant within the work's inner narrative, but as an audience member, external to the fiction, and who is made aware of the conceit behind the painting's appeal to an external beholder. The work thus foregrounds its own fictional nature.

That it is the external spectator that is here addressed is made clear from the half-drawn curtain (a familiar Dutch genre device), a *trompe l'oeil* version of the covers that once protected paintings in Dutch interiors.⁶ The curtain both encourages and delimits our participation; it entices us to draw it open while detaching us from the fictional space depicted 'behind'. It introduces what Hanneke Grootenboer would refer to as a 'rhetorical dimension', in that it establishes contradictory points of view that 'at the level of referentiality are mutually exclusive' (2005, p. 149). According to Grootenboer, such an example of a 'double manifestation of perspective' calls for an 'allegorical mode of looking', because it draws attention to a work's two-dimensionality, 'thus undermining perspective's promise of depth' (p. 165).

So how does my position differ from Kemp's? While I fully acknowledge the status of such signalling elements, and their prepositional role in establishing a work's conditions of access, I want to emphasize their functional role in structuring an encounter between work and beholder. Kemp's discursive emphasis, which focuses on the *interpretation* rather than the *experience*, underplays *The Eavesdropper's* use of its different levels of painted reality. Maes's use of the gesture and curtain might alternatively be understood as signs which

function as imaginative props, whereby we are invited to imaginatively reflect upon our spatial and psychological access to the virtual world the painting presents - and ultimately upon our effective exclusion. The semiotic function of the curtain cannot adequately account for our very real desire to imagine pulling it back in order to reveal more of the 'painting' it part conceals. The 'thought' this work provokes permeates the imaginative experience, and in turn impacts upon *how* we see the work when we revert from imagination to perception. The signs are imaginatively activated as a process whereby the contradictory viewpoints are experienced in the process of viewing, in a way that engages our spatial position directly in front of the work.

Moreover, I will argue that in replicating a bodily frame of reference, works that imaginatively engage a spectator (and particularly an *external* spectator) draw upon non-conceptual content - something denied in accounts where viewing is largely conceived as an interpretive activity. The perception of distance cues is transformed into a nonconceptual engagement that is dependent upon shared frames of reference between ordinary vision, seeing-in and visualization.

Ironically, Wolfgang Iser's *The Act of Reading: A Theory of Aesthetic Response* (1978), a work so important to the development of Kemp's project (Iversen 1993, p. 138), offers a phenomenological account of reading at odds with the privileging of the work *as* sign. For Iser, the reading process is 'a dynamic *interaction* between text and reader', whereby the text 'can activate the individual reader's faculties of perceiving and processing' (p. 107). Indeed, Iser's emphasis on the reader entangled in a situation constitutes what is more accurately described as a 'theory of aesthetic response (*Wirkungstheorie*)', rather than a theory of reception (*Rezeptionstheorie*) (p. x).⁷ Iser maintains 'it is called aesthetic response because, although it is brought about by the text, it brings into play the imaginative and perceptive faculties of the reader, in order to make him adjust and even differentiate his own focus' (p. x). This has obvious relevance to Maes's painting. If the function of beholding has already been incorporated into the work of art, it is because the work *structures* an encounter with its beholder, the reciprocity it prompts being very much an imaginative and perceptual response by a viewer reacting to both marked surface *and* fictive scene. It is the latter that concerns this thesis. And as Iser notes, such a structuring avoids the so-called 'affective fallacy',⁸ where the work and its effect are confused, in that the concern of an aesthetics of response is 'with the structure of the "performance" which precedes the effect' (p. 27).

In constructing what might be termed an *experiential*, and, indeed, *psychological* version of reception aesthetics, sensitive to the role signs play in structuring the conditions of access, the thesis will focus on the particular role imagination plays in a work's reception, and on the reciprocal interaction engendered between artwork and beholder. After Merleau-Ponty, I refer to this as a kind of *seeing-with*, a seeing 'according to' the painting (1993c, p.

126). It is a use to which pictures are put. I believe that imagination, and particularly 'iconic' imagination,⁹ is pivotal to the implied reciprocity between painted scene and beholder. As Spinicci has observed, this is *not* an objective spatial relation, but 'an apparent spatiality in which – *in the form dictated by the image* – this relationship between the depicted scene and *possible observer* unfolds' (2008). Crucially, the work is able to structure such an interaction only because imagination provides a vivid experience of pictorial depth, providing the work in question supports such an engagement. As such, I question Wollheim's assumption that while an internal spectator offers a distinctive access through the role imagination plays in pictorial seeing, paintings that engage an external spectator can only do so through illusory means.

Unlike Kendall Walton (1990), I am not here arguing that imagination grounds *seeing-in*,¹⁰ an activity that I would contend is *prior* to *seeing-with*. Rather, imagination plays an ancillary but nonetheless important role in the beholding of many representational paintings: and particularly those completed by the presence (or, indeed, absence) of an implied spectator. As Spinicci puts it, 'the imaginative dimension is called into play not by the concept of depiction as such, but only by the *use* we make of depictions when we are willing to take part in the game they propose' (2008). *Seeing-with* is supplementary to an experienced resemblance,¹¹ and plays little or no part in the recognitional aspects of depiction – what it is to see an absent object in a marked surface. But a theory of resemblance, with its risk of a referential bias, only gets us so far; not only does it fail to explain our enjoyment of representational diversity (the *way* pictures represent) (Lopes 1996, pp. 8-11), it cannot account for the interaction common to so many works that engage us spatially and psychologically. As such, while I do not here claim to present a comprehensive theory of pictorial representation, I develop what I believe to be a key aspect of an 'expanded' account of representational seeing: 'expanded', in that while I do not believe imagination is essential to what Budd refers to as the 'unadorned experience' of representational seeing (1992, p. 275), it *is* essential to the vivid experience of pictorial depth, and to the reciprocal engagement that accompanies an identification with the implied spectator position.¹² *Seeing-with* involves a perceptual shift in gear, where the perception of a marked surface is augmented by the imagination, within a framework set by (and anticipated by) the work. The thoughts and emotions this encounter engenders permeate subsequent perception, in a way that makes the engagement with the painting more replete.

2.

I situate my philosophical line of enquiry primarily within the tradition of analytic philosophy of art. As such, my position is at odds with much contemporary visual art theory, with its predilection for structuralism or poststructuralism in all their guises. But I do not limit my enquiry to analytic sources, in that I also reference the reception aesthetics

of Kemp and the phenomenology of Merleau-Ponty. I do not attempt a systematic reconciliation of these different frames of reference and styles of argument, nor do I attempt a survey of the relevant literature. Rather, I have allowed the argument itself to determine the points of reference on which the thesis draws. My interest lies with the pursuing of the argument rather than an interrogation of the diverse resources on which I draw.

The perceptual and experiential emphasis of many analytic and phenomenological theories of representational seeing is in marked contrast to the dominance of linguistic derived theories with their distinctive vocabularies.¹³ But I am also aware that the rather too casual dismissal of structuralist and poststructuralist theories can be at the expense of a genuine engagement with contemporary debates within the art school context I teach in: an environment where analytic approaches are all too seldom addressed. Moreover, in addressing theories of an artwork's reception, I am forced to confront semiotic accounts that have rather staked out this territory as their own.¹⁴

Wary of the charge of too easy a dismissal, let me briefly set out my position in relation to one of the more plausible semiotic accounts of painting. Outside of the analytic tradition, there is wide acceptance that paintings are 'read' rather than perceived. Despite the currency of this notion, a claim for the vulnerability of semiotic accounts is made by Wollheim, who argues that, unlike language, 'in the relevant, or combinatory, sense, pictures lack structure. There is no non-trivial way of segmenting pictures without remainder into parts that can be categorized functionally, or according to the contribution they make to the meaning of the whole' (2001a, p. 14). Wollheim's target here is a family of theories that 'ground representation in a system of rules or conventions that link the pictorial surface, or parts of it, with things in the world' (p. 14).¹⁵

While I broadly agree with this in terms of recognitional aspects of painting, unlike Wollheim I believe that certain paintings do structure their conditions of access: and this is precisely a functional, rather than formal, categorization. But acknowledging a work's propositional structuring of the conditions of access is not the same as grounding depiction upon a system of rules or conventions that connect image to object, and can remain ancillary to an experienced resemblance. I would argue that perspective, combined with framing, has a particular role in structuring our implied spatial relationship to painting. Masaccio's *Trinity* (fig. 2), a work central to my argument, represents a rare paradigmatic shift in the history of reception, precisely because it engages a spectator position as part of the work's semantic content. As we shall see, *Trinity* distinguishes between those parts of the painting implied as spatially in front of the fresco's supporting surface, and those implied as behind: a categorical distinction that, contrary to Wollheim's argument, is fundamental to the work's meaning.

Now this might initially seem to have something in common with Hubert Damisch's structuralist position, which argues for an alternative 'semiological analysis that does not

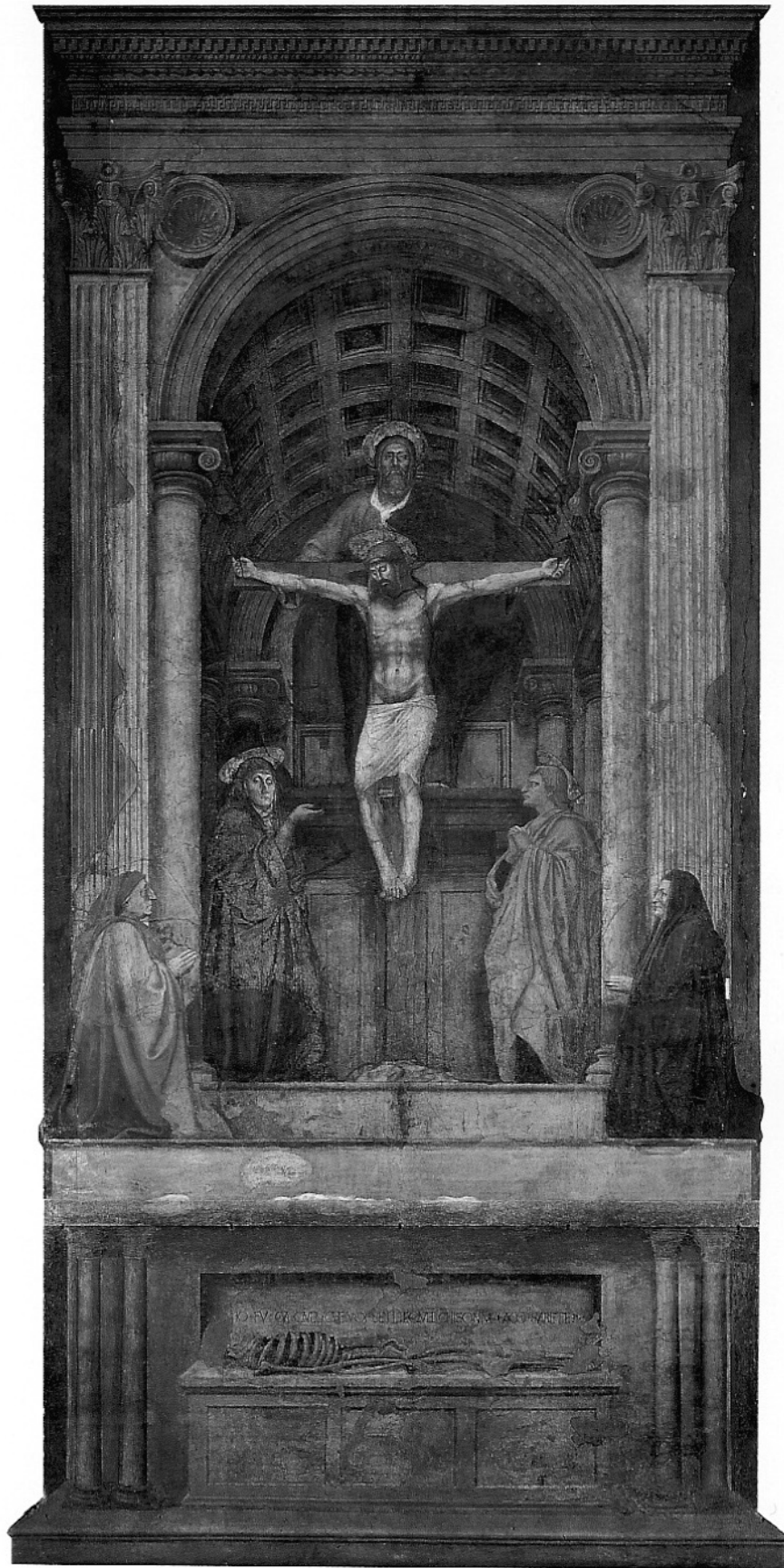

Fig. 2 Masaccio: *Trinity* (c. 1425-27), Santa Maria Novella, Florence.

set out by acknowledging its dependence upon the linguistic (phonetic) model' (2002, p. 14). In *A Theory of /Cloud/* (2002) Damisch claims:

Such an analysis cannot possibly proceed simply by a functional division of the painted surface into its constitutive parts, and then by breaking down these parts, in their turn, into the elements of which they are composed. On the contrary, it needs to circumvent the flat surface upon which the image is depicted in order to target the image's texture and its depth as a *painting*, striving to recover the levels, or rather the registers, where superposition (or intermeshing) and regulated interplay – if not entanglement – define the pictorial process in its signifying materiality. (p. 14)

Indeed, I agree with Damisch that a functional relationship must circumvent the two-dimensional surface, and address a picture's depth as a painting. Damisch likewise assigns a particular epistemological status to perspective, in terms of its structuring of pictorial depth. And yet Damisch's structuralist position is still heavily dependent upon theories of language taken from Émile Benveniste and Jacques Lacan, positing a *subject position* rather than an implied spectator as such. Now, analogies with language have their uses, as we have seen in an earlier note with regard to Wollheim's characterisation of 'iconic' states; however, the notion of subjectification tends to limit how we might experience painting's depth, and specifically curtails the kind of experiential encounter I propose is provided by iconic imagination – an encounter between painting and an *embodied* viewer.

In *The Origin of Perspective* (1994), Damisch puts forward a complex argument that painting is a form of thinking. In claiming that perspective 'functions' as a model of thought, he proposes that it is perspective which structures a picture's situatedness. Damisch argues that perspective is not a code, nor, in itself, a symbolic form;¹⁶ rather, 'the formal apparatus put in place by the perspective paradigm is equivalent to that of a sentence, in that it assigns the subject a place within a previously established network that gives it meaning, while at the same time opening up the possibility of something like a statement in painting' (p. 446). Perspective provides a formal apparatus replete with deictic references such as '*here, there, and over there*' (p. 446).¹⁷ It is a *spatial* thinking: the subject is 'always posited in relation to a "here" or "there", accruing all the possibilities for movement from one position to another this entails' (p. 53).

However, it is a spatial thinking that is conceived within discursive limits, where the emphasis on a structure akin to a sentence assigns an implied subject position within a closed interpretive network.¹⁸ Crucially, it does not adequately distinguish between the kind of spatial access afforded a description and that afforded a painting. Thus while Damisch refers to 'entering into the painting as if it were a "scene"', whereby both 'subject' and the 'other' are conceived as 'already there' (p. 446), the flat surface of painting is ultimately only circumvented within the closed loop of the symbolic order, thus requiring no role for a spectator – whether conceived as internal or external to the work. This means

that the painting is 'read' rather than 'experienced', an essentially interpretive rather than perceptual activity.

Like Damisch, I also believe perspective, or more accurately perspective 'combined with framing' (Maynard 1996, p. 27), structures a pictorial situatedness. This is, in part, undoubtedly conventional. Not in Erwin Panofsky's sense of perspective as a symbolic form, nor Damisch's notion of perspective as a signifying system; rather, perspective structures its conditions of access through the integration, or non-integration, of bounding frame (and/or projection plane) into the implied figurative space. As Svetlana Alpers notes, one might compare Italian picture frames, which resemble architectural elements such as window or door surrounds, with Dutch frames, that 'resemble instead the frames on mirrors' (1989, p. 42). One lends itself to a suggested continuity, the other a cutting into a prior reality. With perspectival representation, distance cues, such as foreshortening and occlusion, are readily transformed into an imaginative engagement that admits a strongly felt pictorial depth: an engagement that includes an iconic identification with the spectator position relative to the virtual world of the painting. While analogies with language, such as Benveniste's 'I-You' polarity (1971, p. 218), might serve some *explanatory* use in terms of distinguishing between relative positions of beholder and fictional space, the prepositional role imagination plays in experiencing pictorial depth affords something a description cannot, an implied *spatial* access to the scene. And, at least with certain works, this engages the 'real' space of the beholder in a way that draws upon nonconceptual content.

3.

Damisch's account nevertheless has much to recommend it, not least its recognition of perspective as an extraordinary cognitive achievement and paradigmatic shift (Iversen 2005). I will go on to reference Damisch at a number of points, and in Chapter Six I refer to his *A Theory of /Cloud/* (2002) in discussing the depiction of supernatural phenomena that lie 'beyond' perspectival representation. Semiotic accounts of painting that import linguistic terms such as denotation and connotation fare much worse, and fail to capture the distinctive phenomenology of pictorial representation. Denotation cannot explain *how* it is that we 'see' something within a marked surface. As Paul Crowther notes 'denotation – in all its varieties – does not define pictorial representation, but is, rather, one of its major uses' (2002, p. 90).¹⁹ It is a non-pictorial form of representation that pictures utilize. Accounts reliant on denotation and connotation prove inadequate in answering Merleau-Ponty's question as to '*where* the painting is I am looking at' (1993c, p. 126), which I pose in Chapter One, precisely because they jettison any such need for a 'spatial' engagement with the work.

What is not at issue here is the fact that many depictions do, indeed, employ signalling elements. Paintings represent in more ways than one, including the use of signs and symbols

that have to be interpreted. But this is different from claiming that what is distinctively *pictorial* about how pictures represent is their status *as sign*. Hopkins makes the distinction clear:

Many pictures from the religious art of the West represent the Holy Spirit by depicting a dove. I suggest that there is not one form of representation here, but two. The dove is depicted, but the Holy Spirit is represented in some other way. After all, the Spirit is only represented by virtue of the fact that the dove is, but the converse is not true. This suggests that the representation of the Holy Spirit is a far more complex, more derived phenomenon than the representation of the dove. Further, a description of the scene which mentioned a dove might represent the presence of the Holy Spirit in a similarly derived manner. This provides at least some reason for thinking that the description and the picture represent the Spirit in the same way, a way that will not therefore be distinctively pictorial. In contrast, they represent the dove in very different ways, and the difference is precisely that between pictorial and linguistic representation. (1998, p. 9)

As Budd notes, in such circumstances 'what a picture represents on the basis of its pictorial content can exceed what it depicts' (2004, p. 394). A work can gain content from wider associations outside of what is depicted in its marked surface, including extra-pictorial meanings. Indeed, often such associations are provided by the work's title. Wollheim's chapter on 'Painting, Textuality, and Borrowing' in *Painting as an Art* (1987, ch. IV) describes how certain paintings gain *textual meaning* when a text enters the content of a painting (p. 187). As Wollheim acknowledges, such 'propositional meaning' might be seen to conflict with his argument about the differences between pictorial and linguistic meaning. And yet there is no inconsistency, in that 'to maintain that pictorial and linguistic meaning are quite unlike is not to claim that a painting can never mean what a piece of language means' (p. 187). The important distinction is that while such extra-pictorial meanings require interpretation, depiction itself is 'bound to the visual', in that, to quote Hopkins, it 'involves a special visual *experience* on the part of the viewer' (1998, p. 15). It is this requirement to account for the visual aspects of depiction that ultimately rules out semiotic accounts from providing an adequate account of the pictorial aspects of representational seeing. And if indexical signs are used to structure our implied spatial relationship to painting, they do so because they function as prompts for an imaginative engagement that, in its reciprocity between work and beholder, far exceeds the notion of the 'reading' of signs.

4.

Some semiotic accounts are openly hostile to a role for perception. Despite arguing for a 'visual' semiotics, Norman Bryson's *Vision and Painting* (1983) – a work I reference in Chapter Four – maintains that Ernst Gombrich's assertion that a painting is a record of a perception is not only wrong, but '*fundamentally wrong*' (p. xii). He argues that 'it is not in

the contingent and undemonstrable mysteries of perception that realism forges the special relationship between denoted and connoted meaning ... but in the contradiction installed by a univocal iconology, between the necessary and the gratuitous' (p. 65). Bryson has in mind what he terms the excess of information presented by realist painting, beyond the requirements of denotation.²⁰

In Bryson's account, meaning is not to be 'discovered *in* the painting' but in the 'interaction of painting with social formation' (p. 85). Here Bryson acknowledges a debt to Roland Barthes's reader-oriented notion of 'The Death of the Author' (1977), in that meaning for Bryson accrues in the shifting relationship between the painting and its subsequent reception rather than the work of art. Consistent with its status as one of the first attempts to apply reception history (*Rezeptionsgeschichte*) to painting, *Vision and Painting* shifts meaning from the work itself to its subject-oriented reception; meaning for Bryson becomes a 'variable term fluctuating according to the fluctuations of discourse' (Bryson 1983, p. 85). And with Bryson's frequent collaborator, Mieke Bal, *every* detail, however seemingly insignificant, becomes a sign to be obsessively interpreted. For Bal the constantly shifting interpretant means that: 'As soon as the mental image takes shape, it becomes a new sign, which will yield a new interpretant, and we are in the middle of a process of *semiosis*' (1998, p. 75). Interpretation becomes an end in itself, rather than a means to experience the work.

The contrast with experiential accounts of depiction has particular relevance to the *beholding* of paintings. We are here faced with conflicting paradigms: on the one hand, accounts where interpretation is a *construction* of meaning by the viewer, and on the other, accounts of representational seeing that demand a specifically visual experience in order to unlock meaning embedded in the work. This might be registered as a methodological divide between anti-intentionalist accounts, where interpretation is assigned to a work's reception, against 'retrieval' accounts, where meaning resides primarily in an internal arc between artist and artwork, and therefore involves necessary constraints. In 'Criticism as Retrieval' (1980c) and *The Mind and its Depths* (1993), Wollheim sets out just such an opposition. For Wollheim, meaning is also not to be found *solely* in the painting, although he identifies the work of art 'as the proper object of critical attention' (1980c, p. 200).²¹ Wollheim observes: 'Where meaning is thought of as something to be discovered, the critical aim is Retrieval: where meaning is something to be constructed and imposed and (presumably) done so afresh from age to age, the critical aim is Revision' (1993, p. 134). Importantly, for Wollheim a criticism as retrieval includes the creative process itself as part of the 'meaning-bearing properties of the work' (1980c, pp. 199-200).

5.

The question arises as to the relationship between critical retrieval and the artist's intention. One of the benefits of shifting focus onto the creative process is that it can avoid extreme forms of intentionality, without denying that a painting is a product of intentional activity.²² As Carolyn Wilde has noted, Wollheim's insistence on a psychological account to meaning in painting does 'not need to assume that artistic intention is something separable from what is presented in the work'; moreover, nor should 'any statement of the artist's intentions, should they be presented independently from scrutiny of the work, have any over-riding authority about what is to be seen in it' (Wilde 2001, pp. 123-124). This is important in that we cannot know an artist's *actual* intentions - even when we have access to the artist's own words. But this problem is alleviated if we distinguish between the creative process and the artist's intention. Wollheim argues that the former is more inclusive than the latter, in that 'the creative process includes the many background beliefs, conventions, and modes of artistic production against which the artist forms his intentions'; this is an inclusive list that includes 'current aesthetic norms, innovations in the medium, rules of decorum, ideological or scientific world-pictures, current systems of symbolism or prosody, physiognomic conventions, and the state of tradition' (1980c, pp. 200-201).

Moreover, the most important consequence of such a distinction for a criticism as retrieval directly follows:

In recording an artist's intention the critic must state it from the artist's point of view or in terms to which the artist could give conscious or unconscious recognition. The critic must concur with the artist's intentionality. But the reconstruction of the creative process is not in general similarly restrained. The critic must certainly respect the artist's intentionality, but he does not have to concur with it. On the contrary he is justified in using both theory and hindsight unavailable to the artist if thereby he can arrive at an account of what the artist was doing that is maximally explanatory ... Anachronism arises not when the critic characterizes the past in terms of his own day, but only when in doing so he falsifies it. (Wollheim 1980c, p. 201)

The argument that we cannot claim absolute knowledge of the object of art history therefore misses the crucial point. When the process of understanding is seen as 'essentially experiential', even when there is a large gap between the perspective of the artist and of the interpreter, reinterpretation *requires* that we look again: 'understanding a work of art is ... understanding by acquaintance' (Wollheim 1993, p. 142). We test our renewed understanding against the works themselves, in the light of our being an *appropriate* audience, in that we have put ourselves in the best possible position with respect to the work's reception.

6.

Now, while broadly sympathetic to Wollheim's methodological arguments for a *criticism as retrieval*, I believe they have a particular blind spot. The emphasis on the archaeological analogy of retrieval means that Wollheim, by and large, excludes the work's reception from its meaning-bearing properties; and yet I see no reason why an experiential account of the aesthetics of reception cannot be reconciled with a criticism as retrieval, if we consider what is being retrieved in the experience of a painting as a structured relationship between artwork and viewer that is *implicit* to the artwork. Importantly, an implicit observer need not rule out a 'dialogic' dimension: imagination can provide just such a dialogic relation, without falling into claims of beholder authorship. Wollheim does, in fact, allow one such possibility for a distinctive imaginative access to a work, but one that he limits to very specific paintings. Wollheim argues:

I too find a place for imagination in my account of representational meaning, but it is a place that is ancillary to seeing-in, and is relevant only to certain paintings. These are paintings in which the suitable spectator is offered a distinctive form of access through the presence in the represented space - though not in that part of it which is represented - of a figure, whom I call the Spectator in the Picture. The Spectator in the Picture has, amongst other things, a psychological repertoire: a repertoire of beliefs, desires, attitudes, responses. What then happens is that the suitable spectator, the suitable *external* spectator we might say, starts to identify with the internal spectator: that is, to imagine him centrally, or from the inside, interacting with the represented scene as the repertoire assigned to him allows or constrains him to. The net result will be that the external spectator will find himself in a residual state analogous to that of the internal spectator, and this state will in turn influence what he sees in the picture when he reverts from imagination to perception. (2001a, p. 25)

Here, unlike the viewer of Maes's painting (fig. 1), the implicit viewer occupies an unrepresented extension of the fictional world of the painting. The key point for Wollheim is that this imaginative engagement influences what is seen in the picture - it *adds* something unavailable to perception alone. As Wollheim notes elsewhere, such works have 'a representational content in excess of what they represent' (1987, 101), an excess that accrues from the reciprocal interaction that follows between internal spectator and depicted scene.

Leaving aside, for now, the issue of whether there can be more open-ended intentions on the part of the artist in imagining such internal spectators, I want to briefly examine the implications of this representational excess: an excess that arises from a change in perceptual gear, where perception is supplemented by imagination. It follows an identification, on the part of the external beholder, with a figure occupying what Hopkins terms the 'depiction point' - a point '*implicit* in the picture', which is to be distinguished from the place occupied by a spectator standing, for instance, within a gallery space or museum (2004, pp. 150-151). Now I have already indicated that I will go on to argue that in certain works the position

of the internal and external spectators can merge: in such cases, the depiction point is integrated into the processional demands of the picture's host architecture. But, likewise, leaving this issue aside for now, it seems to me that such an identification with a point of view offers a representational excess unavailable to figurative sculpture. This directly follows on from the fact that, as Hopkins has argued, sculpture presents no depiction point, no position (or multiple positions) *implicit* to the work (p. 166).²³ Although sculpture can undoubtedly suggest the presence of implied spectators, perhaps by 'inviting' us to occupy a position as part of a figurative group where an appropriately vacant place has been left to occupy,²⁴ it cannot - in the manner of painting - present a scene from one particular *point of view*, 'through the eyes of' a protagonist who is implied but unrepresented.

Now, in that this aspect of representational seeing seems genuinely to distinguish painting from representational sculpture, it seems to me of such significance that we might question the restriction of the role of imagination to such tightly constrained cases presented by Wollheim's spectator in the picture. While only certain works imply an unrepresented internal presence, it is more widely through the imagination that we are able to see a fictive scene as if from a particular 'point of view'. Indeed, one can accept that there is a difference in role, a 'division of labour ... between perception and imagination in our interaction with representational paintings' (Wollheim 2001a, p. 26), and still argue for a widening of the criteria to which such an engagement might apply. As Walton justifiably asks of Wollheim's position:

Why cannot the viewer imagine seeing the depicted objects from a given perspective without having such a spectator to identify with? (2002, p. 30)

Indeed, as Walton notes, given his 'marvelously rich and perceptive explorations of pictorial representation', it is perhaps surprising that Wollheim has so 'little to say about the perspectives or points of view from which things are depicted' (p. 29).

Wollheim's objection would no doubt be to ask: What is gained by such imaginings, over and above that available to perception? While it might indeed be argued that perception, unaided, is sufficient to provide the necessary information a beholder requires to comprehend the scene, the imagination provides an additional *experienced* reciprocity, but only if, as Spinicci remarks, we are prepared to '*accept the game proposed by the image*' (2008). Crucially for my position, if imagination provides a vivid experience of pictorial depth, over and above the registering of distance cues, surely this must *include the space between beholder and picture*: it structures our implied conditions of access, and the intimacy of our proximity to figures within the fictive scene. This notion of an experienced reciprocity, spatial *and* psychological, is at the very heart of my argument. As I will attempt to show, this reciprocity can be a factor even when the beholder identifies with a depiction

point that is unoccupied. As we shall see, the absence of a viewer can have equal pictorial significance to her implied presence. There is a direct parallel here with Iser's argument with respect to the implied reader of literature:

The concept of the implied reader is therefore a textual structure anticipating the presence of a recipient without necessarily defining him: this concept prestructures the role to be assumed by each recipient, and this holds true even when texts deliberately appear to ignore their possible recipient or actively exclude him. (1978, p. 34)

The thesis thus fuses the concept of the implicit observer, taken from reception aesthetics, with an analytic derived theory of the structuring role of the imagination - a theory itself founded upon the structuring possibilities of perspective *combined* with framing. While linguistic clues may play some part in understanding such relationships, this structuring is conceived not as a 'subject position', internal to the work's symbolic order, but rather utilizes indexical signs as to our implied access as imaginative props: props that determine the nature of our spatial and psychological participation or exclusion.

7.

I offer one final methodological note. This is *not* an art historical study. While at a number of points I illustrate the theoretical ideas by examples of painting, these examples are drawn from a range of art historical periods, consistent with an emphasis on the phenomenology of the seeing of painting rather than art historical analysis. Such examples are not offered as comprehensive interpretations of individual works, but serve to clarify the general theoretical argument.²⁵ One possible accusation that could therefore be made against my position is that of ahistoricism, a charge that has been made against both analytic philosophy and phenomenology. Indeed, I am substantially in agreement with the claim that *many philosophical problems persist outside of narrow historical and cultural constructs*. I do not aim at an historical account of painting - in all its positivist applications - nor its reception - an approach that characterizes *Rezeptionsgeschichte* (reception history). Equally, it is not my intention, as with Michael Baxandall (1988), to construct a period gaze, and hence reconstruct a 'real' historical viewer. My interest is with the viewer implicit to the work. To adapt Iser, this viewer is 'a construct', and 'in no way to be identified' with any real viewer (p. 34).

Yet, I am not indifferent to issues of context. Kemp argues for a sensitivity towards the historical and cultural circumstances of the beholding of painting, while likewise differentiating *Rezeptionsästhetik* from those studies 'devoted to the historical reception of art' (1998, p. 181). Nevertheless, Kemp (and here we part company) distinguishes the aesthetics of reception from the 'psychology of reception', claiming that the latter 'necessarily entails an ahistorical way of proceeding', in that 'this approach removes the process of

reception from the conditions of reception' (p. 182). He has in mind Gombrich's notion of the 'beholder's share' (1977), but he might equally point to Wollheim's psychological account in *Painting as an Art* (1987). However, in insisting on an experiential account that is *psychological*, does this necessarily imply such ahistoricism? A psychological account involving a reciprocity arising from embodied perception does not, by definition, negate a sensitivity toward the historical and cultural circumstances of its beholding. And here, sensitive to a work's conditions of reception, I have tried, wherever possible, to draw upon my own experience of viewing the artworks referenced (with some minor exceptions), a number of which are still in their original architectural and institutional contexts. Given my concern with the conditions of reception, this aspect of the research has been a necessary but hugely enjoyable requirement, and reason enough to undertake a doctorate.

Part One

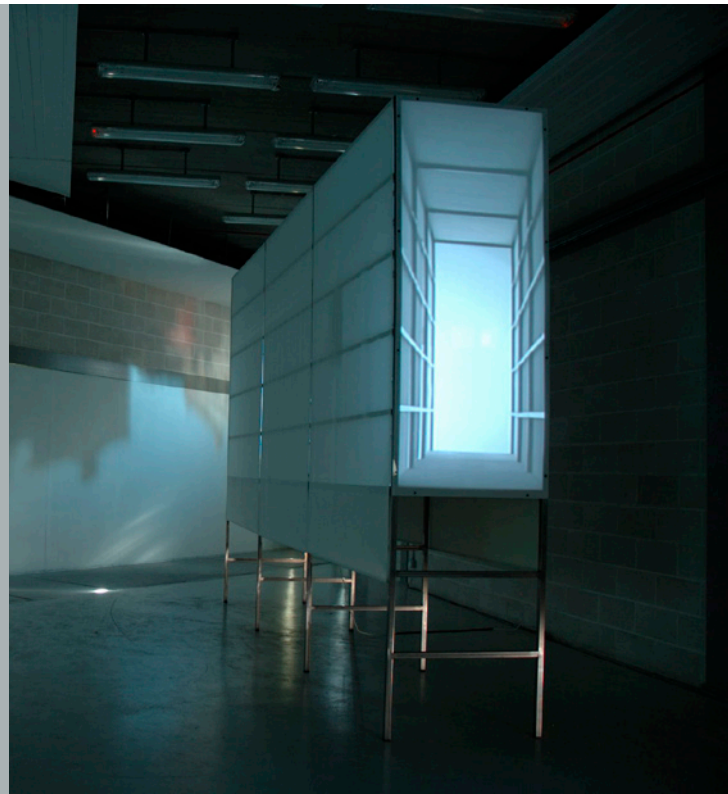

INTERSECTION

2006

The work comprises a metal structure 3230mm high, 830mm wide and 4710mm long. This structure is responsive to its site, but is not site-specific. Two films are back-projected onto acrylic screens that enclose the object at either end, the framed construction housing the mechanisms of projection. The looped films record a woman walking through the space, filmed from either end. The woman appears, and disappears, just as she enters and departs the raised corridor space, her presence contrasted with long periods where the projections appear as still images. The strong orthogonals of the structure form a kind of 'perspective box'. Projected and spatial realities are thus duplicated, in that a filmic space is overlaid onto its originating object. The projected images are cropped to the precise proportions of the acrylic screens, the vanishing points corresponding to an eye height of 1615mm. The installation thus suggests two implicit viewpoints, correlating to the original camera positions. From here, reality and projected reality overlap. But this doubling-up is contradicted by the multiplicity of other possible viewpoints a spectator adopts towards the sculptural object. From oblique viewpoints, the two-dimensional reality of the screens is juxtaposed with the 'real' space behind. While evidently flat, the viewer tries to spatially resolve the projected space that now detaches itself from the three-dimensional space behind. The implied filmic space compresses in relation to the three-dimensional reality of the containing metal structure.

1

A Phenomenological Distinction?

The animals painted on the walls of Lascaux are not there in the same way as are the fissures and limestone formations. Nor are they *elsewhere*. Pushed forward here, held back there, supported by the wall's mass they use so adroitly, they radiate about the wall without ever breaking their elusive moorings. I would be hard-pressed to say *where* the painting is I am looking at. For I do not look at it as one looks at a thing, fixing it in its place. My gaze wanders within it as in halos of Being. Rather than seeing it, I see according to, or with it. (Merleau-Ponty 1993c, p. 126)

1.

The above quotation from 'Eye and Mind' poetically captures some of the richness and complexity of the representational seeing distinct to pictures. The deceptively simple question of '*where* the painting is I am looking at', which Merleau-Ponty admits to being hard-pressed to answer, is an inherent concern of the thesis. More specifically, I address the question in relation to the implied spectator position, relative to the fictional world of the painting. What is it for a painting to be from a particular point of view, from a particular perspective? I will argue that different paintings structure this relationship between viewer and painting in different ways, with particular consequences for works where the implied presence of a beholder forms part of the painting's content.

Merleau-Ponty's question suggests a phenomenological distinction in the seeing of such an 'absent' scene from ordinary vision: what he refers to as a kind of seeing 'according to' or seeing 'with'. Merleau-Ponty states that we do not look at the depicted scene in the same way as we might look at the cracks in the wall's surface. But what is the nature of this phenomenological distinction? The question of '*where* the painting is' arises from a particular feature of pictorial representation that Merleau-Ponty only partially addresses: that representational painting has two distinct perspectives, (i) the absent scene, essentially of a three-dimensional world, represented by a picture's two-dimensional marked surface, and (ii) the external point of view of a spectator occupying 'real' space.¹ Patrick Maynard refers to this feature of pictorial perception as 'Seeing Double' (1994).² The difficulty in saying where the painting is directly follows from this doubling up: we see both a marked surface and the fictive scene, but a scene which excludes the third dimension. And yet we undoubtedly experience the scene as spatial, as having pictorial depth.

It might be argued that Merleau-Ponty's example of the animals at Lascaux confuses the issue, in that we are not here talking about the 'bounded image' of the Western painting

tradition, nor indeed a 'flat' surface.³ As Thomas Puttfarcken notes, 'the cave painters of the stone age knew neither a smooth surface on which one draws nor a clearly defined format' (2000, p. 20). The animals' figural presence was undoubtedly enhanced by the flickering lighting, the darkness of the cave extending beyond the beholder's angle of vision. This thesis, however, will focus on works incorporating what Meyer Schapiro refers to as the 'late' invention of the frame as 'a finding and focusing device placed between the observer and the image' (1985, p. 212). A framed image establishes a self-containment for the absent scene, a separation that significantly impacts upon the question of 'where the painting is'. As we shall see in the next chapter, in certain works the frame itself belongs to both the real world *and* to the painting's fictive reality: to the work's outer and inner apparatus. These are works that establish a concrete tie to the location of the image. But Merleau-Ponty does well to remind us that, with the earliest paintings, it is their very unboundedness that secures a tie to their location – 'elusive moorings', which the images radiating about the wall never quite break.

2.

How is painting's loss of depth overcome? Leaving aside the issue of *trompe l'oeil* works, I will put forward a case that argues that the loss is only really surmounted through the active role imagination plays in pictorial seeing.⁴ I will argue that there are, in fact, two perceptual shifts involved in seeing double: firstly, where we recognize an object as having three-dimensional properties within the pattern of a marked surface, which requires distinguishing an object from its ground, through either outline or occlusion shape;⁵ secondly, where (in works that support such an engagement) we use this prior recognition to imagine the scene in a way that admits a strongly felt pictorial depth. I have termed the latter engagement, after Merleau-Ponty, *seeing-with*, which I claim is an elaboration or augmentation of *seeing-in* rather than constitutive of it. *Seeing-with* describes a particular *use* of pictures. While imagination is not necessary to the registering of distance cues, such as occlusion or outline shape, overlapping, shading and foreshortening, it is essential to a 'vivid' experience of painting's depth, which I contend (and this is not an insignificant point) encompasses the distance between implied spectator and pictorial space. It is one thing to recognize objects as having three-dimensional properties, or that they are depicted as spatially related in terms of being in front of or behind another object: it is quite another to utilize such a recognition in a way that registers our implied position relative to the virtual space painting presents. *Seeing-in* has one phenomenology, distinct from ordinary vision, *seeing-with* another, in that its phenomenology is that of an imaginative engagement licensed by the work, and requiring the spectator's consent. Wollheim's division of labour between perception and imagination is thus maintained.

As such, Merleau-Ponty's question of 'where the painting is' is only really intelligible

with respect to an imaginative or *projective* engagement with painting.⁶ Such a question makes little sense in terms of basic depiction, in that there is no spatial relation other than with the marked surface. My position echoes that of Budd, who in 'How Pictures Look' maintains that it is the 'imaginative projection of the third dimension into the marks on the picture's surface' that provides a 'vivid' experience of pictorial depth, providing the work in question supports such a projection (2004, p. 392).⁷ However, I go further than Budd might countenance, in that I propose that in affording an intense experience of depth in realist painting, imagination also replicates something of the experience of our bodily situatedness in - and reciprocity with - the world. It does so not in a way that merely replicates a *face-to-face* situation. Rather, to adapt Iser's argument in relation to literature, the viewer's projections allows him to experience something 'that would otherwise be precluded by his entanglement in the pragmatic world around him' (1978, p. 167). It allows for *sustained* viewing, a process that unfolds in time. Pictures do not replicate reality, but transform it. This is in part a factor of painting's suspension of time, a suspension of the moment of viewing - a *presentness* of beholding.⁸ But the imaginative projection that forms part of this sustained viewing also has phenomenological consequences beyond what is immediately seen in the picture, in that it implicitly raises the question of a work's *point of view*.

In imagining a painting's depth, the imagined distance (as opposed to the objective distance) is generally relative not to the surface plane or frame (although it is fundamental to my argument that certain, very specific works incorporate the frame and surface into the imaginative project), but to a point of view: namely, the particular perspective that the painting presents, the point of view presented by a work's depiction point. This is a position that lies 'outside' of the painted or drawn surface, but is nevertheless '*implicit in the picture*' (Hopkins 2004, pp. 150-151). It cannot directly be represented within the painting itself.⁹ The distinctiveness of my position directly follows. I argue that Merleau-Ponty's ambiguity of '*where the painting is*' is replicated by an equivalent lack of assurance about our own *whereness*: an ambiguity that I maintain has pictorial significance, in that it is utilized by certain painters in a way that draws the resulting uncertainty of experience into a work's content. And with situated religious paintings, completed by the presence of a spectator, this uncertainty persists *despite* the engaging of the external, whereby the viewer is situated with her feet firmly on the ground in *real space*, yet also *elsewhere*. Indeed, its persistence in the form of a graduated reality is vital to providing a necessary distance from God or Christ. This gradation from the sacred to the actual is, I contend, reliant on an imaginary - not illusory - engagement. Paradoxically, by asserting a separation from the illusory, by giving me work to do, the painter makes it possible for me to believe in the very fictionality of the scene I face.¹⁰

Analogous to Merleau-Ponty's claim that depth is not an 'objective' property, but

something belonging to the perspective of a situated viewer (2002, p. 298), Walton argues that 'it would be a mistake to identify the experience of seeing from a particular perspective with the properties of the thing one sees' (Walton 2002, p. 29). Now the subjectivism of such an argument is open to question: as John Hyman cautions, occlusion shape and size are 'perfectly objective' properties of the things one sees, so that 'whatever a picture depicts, it depicts relative to an implicit line of sight' (2006, p. 82).¹¹ But even if we concede to the objectivist an objective basis to such relational properties, it is surely right to argue for a *pictorial significance* of 'what it is for a depiction to be from one point of view rather than another, or as we sometimes put it, what it is to depict something as *seen* from a certain perspective' (Walton 2002, p. 29). This is precisely the philosophical point I intend to draw out. The objectivist account fails to take into account how pictures manipulate their point of view in ways that support the work's content: for instance, when we are shown something hidden to a protagonist within the pictorial space; alternatively, where something (or someone) absorbs the attention of a figure within the scene, but lies 'off-stage', outside of the bounded image; or where the point of view is analogous to the perspective of a figure within the scene.¹²

A work's frame plays a particular role in structuring such a point of view. As Puttfarcken argues, we should not regard a picture's frame or format, nor its surface or plane, 'as barriers, protecting a "higher-reality-inside" from a "lower-reality-outside", but rather as a structure organizing the relationship between picture and viewer' (2000, p. 20). Importantly, in perspectival works the relation or non-relation between the frame and the depicted scene structures the imaginative relationship between a picture and viewer. It also structures a particular bodily frame of reference relative to a 'line of sight'. And there is a fundamental difference in how such a frame of reference functions between works where the frame is part of the pictorial content, and where it is not.¹³

In order to realize this frame of reference, it is not always necessary (and with frescos is often physically impossible) to take up the precise position immediately opposite the work's vanishing point. As Maynard argues, and many others have noted, perspective is accepting of 'a wide variety of viewing positions' (1996, p. 30). Nevertheless, with certain situated paintings, the representational excess afforded an imaginative engagement is given a greater intensity with the implied positioning of the viewer, who stands or (very likely) kneels before the work.

The significance of imaginatively identifying with a point of view holds, I would argue, even when an implied viewpoint is 'unoccupied'. Indeed, such imaginative projection is surely necessary in order to *determine whether a painting implies a spectator or not*. In some works the viewer's imaginative input can be said to complete the work even when there is no such implied presence: the 'felt' absence of a beholder can be equivalent to an implied presence, such as is the case with Vermeer's *The Music Lesson* (fig. 3). Here, despite signs



Fig. 3 Johannes Vermeer: *The Music Lesson* (c. 1662-65), Her Majesty Queen Elizabeth II, London.



Fig. 4 Johannes Vermeer: *The Music Lesson* (detail).

of the artist's presence reflected in the mirror on the rear wall (fig. 4), the painter himself is absent, and the painting imparts a strongly felt absence that cannot disturb the palpable tension between the man and woman.¹⁴ This is a work that denies the presence of an internal spectator; and yet the viewpoint presented is no less significant in that it allows the painting's beholder to witness in the mirror the subtle twist of the woman's body towards the man, with all its psychological implications (Snow 1994, p. 114).

The importance of taking the viewer's position into account is registered by Puttfarken:

The bounded image is thus described as a two-dimensional structure, which somehow organizes our vision of a pictorial world behind it. Yet before we look at what is behind the picture, we must gain a clearer view of what is in front of it. We must look not only at the relationships between boundary, surface and space behind, but also at the relationships of all three to the viewer: to the fictive space behind the surface we must add both fictive and real space in front of it, between the picture and the viewer. (2000, p. 24)

Indeed, that fictive space encroaches into our reality raises problems with Panofsky's much-

quoted claim that ‘the entire picture has been transformed ... into a “window”’ (1991, p. 27).¹⁵ The simile of ‘seeing through’ fails to account for the fact that so much of a work such as Masaccio’s *Trinity* (fig. 2) is notionally on ‘our’ side of the wall. While a number of art historians have noted this, the theoretical implications are most clearly drawn by Maynard, who argues that the theoretical ‘mix-up of pictorial and (transmission) projection planes’ leads to a conflation of ‘pictures with their real or hypothetical projection surfaces’ (1996, p. 27).¹⁶ While this conflation can occur (and, in part, does so in *Trinity*), Maynard notes that ‘the history of depiction shows we can imagine depicted scenes (perspectival or not), in whole or in part, to be behind picture surfaces, also at those surfaces, in front of them – or in no spatial relationship to them’ (p. 27). This has particular relevance for *Trinity*, in that the space that we imaginatively enter is not that of the religious representation, but the space we ‘share’ with the donors and skeleton, depicted as being in front of the supporting wall.

But as Kemp notes, ‘perspective achieves more than connecting the space of the beholder with the space of the painting’, in that it also ‘regulates the position of the recipient with regard to the inner communications; that is to say, the presentation of the painting with its demands on how it should be viewed’ (1998, p. 187). I would argue that this reciprocity follows from the fact that imagination replicates the experience of our bodily situatedness in two distinct but interrelated ways, which I have already indicated will be the subject of Chapters Two and Three. It structures our implied spatial access to the depicted scene, and – in establishing a bodily frame of reference – it draws upon nonconceptual content.

3.

Before expanding upon my account of the role of *seeing-with* in a work’s reception, some brief consideration must first be given to the claim of a phenomenological distinction between representational seeing and ordinary vision (seeing ‘face-to-face’). We have seen that this is the dilemma of painting’s double aspect: as Budd puts it (1992, p. 264), ‘What is it to see one thing in another?’

In *Picture, Image and Experience* (1998), Hopkins argues that seeing-in does indeed have its own distinctive phenomenology, a special kind of experience that differs from seeing something face-to-face or in visualization. This is evidenced by the fact that there is a phenomenological shift when the marks of a patterned surface are seen as being ‘organized in a particular way’ (p. 16). Hopkins claims:

There seem to be two different experiences here, one preceding understanding the picture, the other accompanying it. The thought ... is that every picture admits of an experience akin to this latter experience. Moreover, the idea is that this second sort of experience holds the key to depiction. If we can discover what is special about it, in particular how it differs from the ‘before’ experience, then, the thought runs, we can analyse picturing. (p. 15)

As such, Hopkins proposes that seeing-in has the following features: (i) it involves 'an experience whose content somehow includes the picture's object'; (ii) that unlike visualizing an object, seeing-in retains 'the awareness of the marked surface before one'; (iii) seeing-in 'is an integrated whole', in that the experience is not fragmented into its constituent parts, and it 'cannot be broken down into elements which could stand alone', in that 'if either the thought of the absent object or the awareness of the marked surface occurred in isolation, the phenomenology of each would be different'; (iv) it sustains the experience of the picture's object in a precise way, whereby seeing-in determines 'what each picture depicts' in a way whereby a picture of a horse 'sustains an experience permeated by the thought of a horse' (pp. 16-17). Nevertheless, Hopkins maintains that these features, while generally accepted by any credible experiential account of depiction, are insufficient in themselves for a theory of depiction: primarily because, as Hopkins suggests, they do not, alone, clarify 'the nature of the involvement of the absent object in the experience' (p. 17).

While offering no supporting arguments,¹⁷ or any attempt to distinguish between the various versions on offer, I believe that what we might refer to, after Budd, as the 'unadorned' account of depiction is best explained by a theory of experienced resemblance - a recognition that is *prior* to any subsequent elaboration. As Budd notes, 'the only relevant sense in which a picture, seen as a depiction of its subject, can look like its subject is with respect to the two-dimensional aspect of the subject's visual appearance' (2004, p. 384). It seems to me that an experienced resemblance is best placed to account for how an absent object enters into the experience of perceiving the painting, whether this is based upon a perceived isomorphism between a two-dimensional painting and a visual field (Budd 2004, or Peacocke 1987), or outline shape (Hopkins 1998). However, it is important to also register the limitations of such a resemblance theory.

Hyman's objectivist account (2006) does just this. Based on occlusion shape, Hyman's theory has much in common with the positions of Budd, Peacocke and Hopkins, but questions the notion of an 'experienced' resemblance.¹⁸ Hyman rejects the need to refer to 'the psychological effect the picture produces in a spectator's mind' (p. 73) on the grounds that it is bound to fail, because 'if we conceive of a picture as an artifact that produces a distinctive kind of experience, we shall find ourselves unable to define this kind of experience, except as seeing a picture and seeing what it depicts' (pp. 142-143). He limits his theory to objective properties of the objects depicted, properties that are independent of our experience of perceiving them. In so doing, he places strict limitations on the remit of any feasible theory of resemblance:

First, the defensible residue of the resemblance theory is not a comprehensive theory of pictorial art. Nothing beyond the basic representation of visible objects falls within its scope. Second, it is a theory of depiction. It purports to define the relationship between the visible objects depicted and the marks and colors on a picture's surface and not the relationship between these marks and colors and the



Fig. 5 Rembrandt: *Jan Six* (1654), Foundation Six, Amsterdam.

person, object, place, or event, if any, that is portrayed. Third, it is not a theory of pictorial perception. And finally, it is also not a theory of artistic perception. For it does not purport to define either the kind of experience that occurs when we look at pictures and see what they represent or the kind of experience an artist needs to have or should be encouraged to cultivate. (2006, pp. 71-72)

Do I agree with these limitations? I accept Hyman's first and second points. (Given my earlier arguments, the reasons should already be apparent.) I also agree with the final point, in that in so far as I understand Hyman's use of the term, I believe artistic perception must incorporate an enriched account of representational seeing, that includes something of Wollheim's notion of twofoldness and what I have termed *seeing-with*.¹⁹ But the advantage of a theory of experienced resemblance seems to me precisely its claim to be a theory of pictorial perception.

Hyman is very insistent that he does not claim to define the relationship between an occlusion shape and colour and the 'person, object, place, or event, if any, that is portrayed' (p. 71). This acknowledges the role non-pictorial factors, including the work's title, can play in defining such a relationship. But at least part of Hyman's reasoning is that certain objects share occlusion shapes – as the duck-rabbit figure demonstrates. As Anthony Savile notes, in his 'Critical Notice' (2007) of Hyman's book, the principles of whether 'it is a rabbit's ears or a duck's bill, or both, or neither' are 'unlikely to be fully elucidated in terms that are

other than mentalistic ones', with the result that for Hyman 'the status of the notions that presuppose [such an idea] is left entirely open' (p. 436).

Hyman's negation of an 'experienced' resemblance therefore sets what I regard as an unnecessarily strict limit where philosophical analysis can go no further. This is revealed in a key passage that references Rembrandt's *Jan Six* (fig. 5), where he writes:

What is needed, in order to achieve a resolution, is a willingness to make concessions on both sides. The subjectivist will have to acknowledge that the occlusion shape principle and the other basic principles of pictorial art relate the surface and the content of a picture without referring to its psychological effect. And the advocate of the resemblance theory will have to concede that these same principles indicate the limit of any definition we could give, of the visible relationship between the marks on a picture's surface and the objects they depict. They indicate this limit because they indicate how far the visible properties of an object in a picture that are expressly marked on the picture's surface leave its exact character unfixed. Its occlusion shape is fixed, but whether it is a piece of gold braid or a pile of books is not. (2006, p. 147)

But if, in the case of ambiguous figures or forms (as opposed to the identity of, for instance, a particular saint), the objective properties of the object are not, in themselves, sufficient to sustain a definitive recognition, then surely the contribution of the suitably qualified spectator is, in such cases, fundamental to the correct perception. The artist relies on the viewer having the requisite knowledge to recognize such objects. Indeed, that the awareness of what a picture depicts is *experiential*, rather than a mere dispositional form of visual awareness (the capacity to recognize or interpret an object in the marked surface) is, as Budd notes, 'seen most economically in the switching of awareness that can take place in the perception of ambiguous figures' (1992, p. 275). What Hyman's account omits is what Wollheim usefully refers to as 'the interlock between perception and cognition' (1980c, p. 134), where in this switching of awareness the concept permeates the perception so that 'experience and concept change not merely simultaneously but as one' (1980b, p. 220). As Wollheim notes, the viewer's 'cognitive stock' (i.e. knowledge, belief, and conceptual holding), whether gained through perception or from factors external to the work, affects *how* we see the painting.²⁰

Indeed, Alpers offers a useful example of how ambiguity is not merely a 'problem' for a philosophical account of representational seeing, but is fundamental to the richer process of artistic perception. In relation to the hand of the painter in Vermeer's *Artist in his Studio* (figs. 6, 7), Alpers writes:

Why such an ill-defined blob? One could say that the painter has not yet realized his hand, in the double sense of not yet having fully perceived the object before his eyes as a hand and not yet having painted it as a hand. An experience of ambiguity is part of the process of perceiving. By pictorial ambiguity I refer to the possibility of the painter representing the perception of a thing, and representing it for viewers, in such a way as to encourage the mind to dwell on perceiving as a



Fig. 7 Johannes Vermeer: *Artist in His Studio* (detail).



Fig. 6 Johannes Vermeer: *Artist in His Studio* (c. 1666-67), Kunsthistorisches Museum, Vienna.

process: the painter's experience of an object as coming into its own, distinguishing itself from other things, taking shape. (2005, p. 27)²¹

This richer notion of perceiving as a process takes us beyond mere recognition. But it is nevertheless grounded upon the very need to incorporate subjective visual experience into a theory of resemblance. And this is the real concession the objectivist must make. To refuse to build this experiential aspect into a theory of resemblance is to limit the remit of the theory one step too far.

4.

If we accept a theory of experienced resemblance as providing the essential involvement of the absent object in the experience, then we can alleviate imagination from having to play any part in the recognitional aspects of depiction. This is the real problem underlying Walton's account of representational seeing, in that he ties the perception of the marked surface and the imagining it prompts into a single phenomenological whole (1990, p. 295).²² And yet, relieved of this commitment, Walton's notion of painting *functioning* as props in games of make-believe (p. 11) might readily be incorporated into an account of representational seeing without the baggage of having to integrate recognitional (or configurational) aspects into the model.

Here it is worth briefly considering Michael Podro's position, which like Walton's, assigns imagination a significant role in the kind of seeing appropriate to representations. Podro, like Walton, asserts that the imagination is central to depiction. 'We use the representation to imagine what we recognize in it': not a free projection or association, but a kind of licensed projection where we represent the thing to ourselves in a way that is corroborated by what the depiction (or its tradition) affords (2001, p. 113). This has the great advantage in that, unlike Walton's account, the imagination is not constitutive of the recognitional aspect itself. But while I agree with Podro that we *can* 'use the representation to imagine what we recognize in it', I do not believe that 'this sense of function or purpose is a defining condition of depiction' (p. 113). Podro fails to explain the very act of recognition that precedes the imaginative project. But as an expansion of the limited remit a theory of resemblance should set itself, then Podro's position can, like Walton's notion of the imaginative prop, be successfully incorporated into the richer account.

As such, for Podro what is important is *how* the marked surface and the content recruit each other 'to make our awareness of the other more replete' (p. 115). Podro argues:

Recognition is the starting point of an elaboration that does not simply return our experience to the pictorial world but brings about a new system of relations in which the recognized subject is suspended and reconstituted. It is critically important and not only philosophically perspicacious to keep in mind the distinction between the functions of recognizing and representing, and given each

its place in an account of depiction, for depiction's mode of representing makes something new for recognition. (2001, p. 116)

By distinguishing between a theory of depiction and a theory of pictorial art, we might better address Podro's objection that recognition does not in itself characterise seeing a scene as a picture. Podro claims that 'depiction is not a matter of some relation like resemblance between the material of representation and the subject matter that it represents: we use the one to represent the other whether to ourselves or to others' (p. 113). Yet we can concede that in its 'unadorned' state depiction might be just such a resemblance, while agreeing that this is an insufficient determinant for representation (a more complex phenomenon, that might also involve extra-pictorial meanings) and for artistic perception. It is with this richer experience that we can likewise acknowledge Podro's claim that we see the 'coincidence between figure and the corresponding areas of paint' in a 'more replete or nuanced way' once recognized, and 'by virtue of the subject that they represent' (p. 115).

5.

We are now in a position to set out the key aspects of the imaginative engagement with painting that I have termed (after Merleau-Ponty) *seeing-with*. I will go on to expand upon this argument in the following chapters. I have argued that: (i) *seeing-with* is ancillary to, rather than constitutive of seeing-in, and is thus *supplementary* to an experienced resemblance; (ii) as such, it describes a particular *use* or *function* of painting, where we see according to the work with the beholder's imaginative consent; (iii) it is independent of (though potentially might enhance) any aesthetic appreciation of twofoldness; (iv) *seeing-with* utilizes imagination to provide a 'vivid' experience of pictorial depth; (v) this imaginative engagement encompasses the distance between implied spectator and pictorial space, and hence our orientation towards the work. In the following chapters I will further argue that: (vi) *seeing-with* allows our presence (or absence) at the fictive scene to become part of a work's content; (vii) *seeing-with* is dependent upon a work's perspective, combined with framing, structuring our implied spatial access, and the means by which the picture surface is traversed; (viii) in providing an intense reciprocity with realist painting, *seeing-with* replicates the experience of our bodily situatedness through a shared frame of reference between ordinary vision, seeing-in and visualization, thus drawing upon nonconceptual content.

6.

It is important to note that such an imaginative engagement is, contrary to Walton's view, essentially *active* rather than *passive*, an activity that has to be sustained. This distinction is consistent with my argument that *seeing-with* is a use of painting. This is most obviously

apparent with regard to an imaginative identification with an implied spectator. But what Budd terms the reversing 'in our imagination the activity of the artist' in order 'to overcome the loss of the third dimension' (2004, p. 392) is equally a directed form of imagination, subject to (if not completely controlled by) the will. I agree with Jerrold Levinson that imagining is 'necessarily *active or contributory*', although, like Levinson, I believe that it is 'not necessarily something one is aware of initiating, and not necessarily something under the complete control of one's will' (2001, n. 3., pp. 36-37).

As such, *seeing-with* has something in common with Wittgenstein's account of seeing an aspect. This is not an account of representational seeing, but raises analogous questions. Wittgenstein famously utilizes the so-called duck-rabbit figure in order to differentiate the "continuous seeing" of an aspect and the "dawning" of an aspect' (2001, p. 166^e). He notes that it is quite feasible that someone might only see the figure as a picture of a rabbit. In such circumstances - where the potential ambiguity of the figure is not noted - it would make little sense to refer to seeing the picture as a rabbit: as little sense as saying, on seeing a knife and fork, "Now I am seeing this as a knife and fork" (p. 166^e). Wittgenstein asks what changes when both figures - rabbit *and* duck - are perceived? Clearly something has changed:

But what is different: my impression? my point of view? - Can I say? I *describe* the alteration like a perception; quite as if the object had altered before my eyes ... The expression of a change of aspect is the expression of a new perception and at the same time of the perception's being unchanged. (p. 167^e)

The experience of seeing an aspect is thus 'half visual' and 'half thought' (p. 168^e), because unlike the perception that a leaf is green, seeing an aspect is, by distinction, subject to the will (p. 182^e). Wittgenstein argues: "Seeing as ..." is not part of perception. And for that reason it is like seeing and again not like' (p. 168^e).²³ As Wollheim argues after Wittgenstein, 'the concept does not stand outside the perception' (1980b, pp. 219-220).

Wittgenstein applies this notion of *seeing-as* to the sudden 'seeing' of a likeness in a face, whereby the same face - which has not changed - is nevertheless seen differently; this involves a different use of the word 'see' to that of a description "What do you see there?" - "I see *this*" (2001, p. 165^e). Wittgenstein's position therefore involves what Budd characterizes as 'an internal relation between the seen object and others' (1992, p. 276), which has obvious potential in relation to the construction of a theory of pictorial experience. And while Budd regrets that 'Wittgenstein does not characterize the nature of the internal relation that is perceived to hold between a depiction and what it depicts' (p. 276), if we accept that an experienced resemblance provides *just* such an internal relation Wittgenstein's account can more usefully be applied as a mechanism for how thoughts prompted by the spatial and psychological reciprocity provided by imagination might permeate subsequent perception.

Wollheim's objection that 'seeing-as draws upon no special perceptual capacity over and above straightforward perception' (1980b, p. 219) is therefore no longer an issue, in that painting's distinct phenomenology is *already* accounted for by an experienced resemblance. Perhaps *seeing-with* might simply be thought of as a variation of Wittgenstein's *seeing-as*, a variation specifically utilizing a beholder's imaginative consent. Here, (i) a perception of a marked surface provides an experienced resemblance that (ii) prompts an imaginative and psychological engagement that includes our implied spatial relation to the virtual scene, and (iii) this in turn leads to a more replete experience where the subsequent thoughts evoked fuse with the original perception, so that the marks – which have not altered – are now 'seen' differently. I would argue that much of the reciprocity we experience with a painting's content follows from this interlock between perception, imagination, cognition and subsequent perception. It provides what Merleau-Ponty refers to as 'the imaginary texture of the real' (1993c, p. 126).

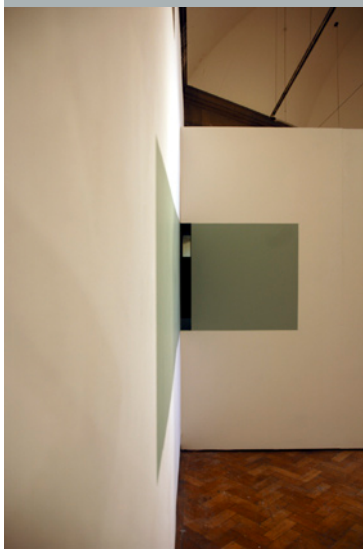

MONOCHROME PASSAGE

2007

Monochrome Passage comprises two 'paintings' in two adjacent spaces, separated by a dividing wall. The work outwardly manifests as four blocks of monochrome colour, two of which are square (800mm x 800mm and 240mm x 240mm) and two rectangular (800mm x 2400mm and 240mm x 720mm). These rigorously geometrical 'paintings' are connected to each other by an internal stepped passage, just 80mm wide. The passage contains seven steps, each 80mm high and 240mm long; the height of this passage thus reduces from 800mm to 240mm. The positioning on the wall enables a viewer to peer from one space to the other, an activity that unwittingly draws the spectator into the work's content. It is only through such an intimate stance, physically pressed against the wall, that the viewer grasps the spatial relationship between the two spaces. As such, what initially appears as separated artworks now registers as one continuous folded form, in effect an unbroken 'frame' belonging to both the work's outer and inner apparatus. The rationality of the work's outward proportions, which uses simple whole number proportions, is sharply contrasted with the essential irrationality of the passage, with its disconcerting ambiguity of scale and exclusion of the external beholder. The openings, flush with the wall, therefore constitute a sculptural equivalent of a projection plane, where two realities are juxtaposed. The work hovers between being a 'painting' (or two 'paintings') and a 'sculptural object', but one that is determined solely by its internal rather than external form. In so doing, it implies two distinct modes of viewing.

2

The Case for an External Spectator

The study aspires to treat a problem belonging to aesthetics proper: namely an examination of the different degrees of reality-effect in the pictures and the false architecture of the time, their 'degrees of reality' in other words. This graduation does not, of course, concern reality; it applies on the contrary to the total unreality characteristic of the forms and objects which the picture seeks to render credible. (Sandström 1963, p. 7)

1.

In 'Painting, Sculpture, Sight, and Touch', Hopkins argues that 'painting presents a self-contained world, isolated from the space in which we, the viewers, view the canvas' (2004, pp. 165-166). Painting, for Hopkins, thus maintains a sharp divide between the space of representation and the 'real' space of the beholder; by contrast, the world sculpture presents is less complete, activating a 'kinetic potential' whereby the surrounding space is drawn into its domain (p. 166).¹ These differences arise from the distinct ways we encounter the work of art. Whereas painting is inherently perspectival, in that it is depicted from a particular point of view, sculpture lacks perspective, 'for it does not share the perspectival structure of vision, nor does it share that of touch' (p. 164). Hopkins distinguishes what he terms the 'depiction point' - a point '*implicit* in the picture' - from the place occupied by a spectator standing, for instance, within a gallery space or museum (pp. 150-151). Conversely, he argues that sculpture presents no such position (or multiple positions) *implicit* to the work, and thereby it 'erodes' painting's sharp division between the world of representation and that of an embodied viewer (p. 166).

In arguing that painting presents such a 'closed' world, Hopkins's view accords with Wollheim's contention that the external spectator cannot become part of a work's content (an agreement that withstands differences in their respective theories of depiction). As Wollheim notes, there is a tendency in much art historical writing to conflate the internal and external spectator: to falsely assume that a painted figure looking outward is necessarily engaging the gaze of a stranger, the viewer *of* the picture (1987, p. 365). Wollheim introduces what he refers to as a 'spectator in the picture' in order to distinguish an internal spectator - a spectator consistent with the spatial and temporal demands of the fictive scene - from this external beholder (ch. III). As we saw earlier, the role of the internal spectator is to provide the spectator of the picture 'a distinctive access to the content of the picture', a content unavailable through perception alone (p. 129). We see the scene through the eyes of

another, who already inhabits the world the painting presents. Hopkins urges caution with respect to Wollheim's overly restrictive demand that, in identifying with the spectator in the picture, the viewer must 'centrally imagine' the internal beholder (i.e. imagine her *from the inside*) as someone other than herself;² nevertheless, Hopkins's notion of a depiction point implicit to the picture is broadly consistent with the imaginative engagement afforded Wollheim's internal spectator. What is important for the current argument is that both philosophers hold that *the implied viewpoint belongs to the virtual world of the painting rather than that of the painting's beholder*. The position occupied by the spectator in the picture is distinguished from that occupied by the spectator of the picture, ostensibly because the latter does not belong, spatially or temporally, to the 'closed' fictive world the painting presents.

This presentation of a self-contained world undoubtedly characterizes works implying an internal spectator. But do *all* paintings that imaginatively engage spectators necessarily present such a closed world? I will argue in this chapter that, at least with regards to a limited range of works, the presence the picture implies can indeed be that of an external beholder, the very beholder that Hopkins and Wollheim seemingly exclude. In such works, the spectator of the picture might be said to *fuse* with the spectator in the picture: the internal imagining is situated, in that it draws into the imaginative experience aspects of the real architectural situation the spectator finds herself in, whereby the works are completed by the embodied presence of such a viewer.³ Without collapsing the differences between painting and sculpture, especially with regards to a *point of view*, these paintings do something that Hopkins argues only sculpture is capable of doing: they draw the surrounding space into their domain.

Now I concede to Hopkins that this is *not* the full activation of space typical of the viewing of sculpture.⁴ On the contrary, paintings address us frontally, unlike sculpture's presentation of a world that surrounds us. And yet perspective transfigures this frontal presentation of depth into an experience that admits something of the world's surroundedness. As David Summers notes, an 'image on surface immediately assumes real spatial relations (size in relation to observers, manner of facing) but the inequality of image and surface also makes it possible to *represent relations as relations*, either on the surface itself (next to, above, equal to) or in virtual space (far, near, before, behind)' (2003, p. 335). In certain works, I would argue that this foregrounding of spatial relations locates a spectator in such a way that a work's implicit viewpoint fuses with the position we occupy in *real space*. Moreover, in so doing it allows our implied access, or denial of access, to constitute part of the work's content. Paradoxically, in thus drawing an awareness of the surrounding architecture into what I stress is an *imaginative* experience, I argue that such paintings erode something of the sharp division between the world of representation and that of an embodied viewer while maintaining a necessary gradation of reality. As Merleau-

Ponty puts it in relation to the paintings at Lascaux, the work is neither wholly 'there' nor 'elsewhere': an uncertainty that must also encompass the spectator position. The viewer is drawn into the work's domain as a physical presence while at the same time external to it, kept at a distance. This constitutes a special case that, crucially, is only made possible through the imaginative engagement I have characterized as *seeing-with*.

2.

What is not at issue is that an implied viewer of the scene presented cannot be represented within the scene itself, precisely because such a viewpoint lies 'outside' of the representational scene. In the case of works implying an internal spectator, Wollheim claims that they have 'a representational content in excess of what they represent', an excess that derives from an identification that provides a reciprocity with the fictive scene (1987, p. 101). In this chapter, I extend the notion of representational excess to works implying an external spectator, in that such works are completed by the presence of a beholder.⁵

I would further argue for a wider significance to the fact that painting posits this absent viewpoint regardless of whether this place is 'occupied'. Certainly, as already noted, works where there is a 'felt' absence, such as Vermeer's *Music Lesson* (fig. 4), might also be said to have a representational content that exceeds what they represent. The occupation (*or not*) of the depiction point may be relevant or irrelevant to the scene. Where relevant, the spectator may be acknowledged or unacknowledged, casually disregarded or consciously ignored. Clearly, not all works would *gain* representational content from such imagining: nevertheless, the imagination must, at the very least, play a role in determining what kind of spectator is implied. What I really want to question in this chapter, however, is whether this space of the implied viewer – Hopkins's depiction point – is necessarily only intelligible as an extension of the virtual space of the depiction, or can it *additionally* engage the actual space in which the spectator stands? Is what Spinicci refers to as the 'perceptive split between figurative and real space' (2008) one where the figurative space must remain closed (of course, in terms of its *implied* rather than *objective* spatiality)?

3.

In 'Sculpture and Space', Hopkins concedes the possibility of *some* interaction between the depicted space and the space the viewer occupies. In particular, he acknowledges that in works such as Masaccio's *Trinity* (fig. 2) continuity is suggested between the depicted space and the physical space of the church (2003, p. 289). But while the space of reception is here 'experienced as organized a certain way, and it is so as a result of grasping the picture's content', Hopkins argues that 'the organizing principle is not the potential for action' that Langer has identified is particular to sculpture (p. 289). And yet while I am



Fig. 8 Mantegna: *Camera degli Sposi* (frescoed vault; c. 1465), Castello di San Giorgio, Mantua.

not arguing that *Trinity* activates the full kinetic potential of sculpture in the round, it nevertheless activates something of the space immediately in front of the work. As we shall see in the next chapter, this activation is not dependent upon our physical mobility as such, but a kind of implicit bodily readiness that draws upon our awareness of the real space in which we stand.

Hopkins suggests that the pictorial examples that come closest to the 'Langer phenomenon ... seem rather trivial achievements, somewhat as illusionistic triumphs are' (p. 289). But is the implication of a spatial continuity *necessarily* illusionistic in intention, or can it be in the service of an imaginative projection, licensed by the work in a way that grants us a distinctive access to the content of the picture?

Leaving aside any objection as to whether *trompe l'oeil* works, such as Mantegna's *Camera degli Sposi* (fig. 8), can be described as 'trivial achievements', it would be wrong to treat *Trinity* as primarily an illusionistic work, even though it is often misleadingly described as such.⁶ The argument is worth pursuing. Wollheim maintains that works that 'trade on illusion' require a 'subversion of belief on the part of the spectator of the picture' (1987, p. 185). As Wollheim rightly argues, the 'imagination and illusion are quite different'. Thus:

[T]here are pictures which could be unthinkingly be confused with those I have been talking about [i.e. works implying a spectator in the picture], and these generally do involve illusion to some



Fig. 9 Masaccio: *Trinity* (detail; c. 1425-27), Santa Maria Novella, Florence.

degree. These are pictures which do not ask us to identify with someone entering the represented space: rather we are expected to believe on the basis of what we see that a represented figure enters our space. (p. 185)

Rather than requiring such a subversion of belief, I would contend that *Trinity* calls for an imaginative engagement whereby the beholder registers different parts of the picture as having different levels of reality. This is not to deny that *Trinity* presents features later adopted by *trompe l'oeil* works: it implies a spatial continuity by placing the vanishing point at the viewer's eye level, depicting the figures as life-sized, and repeating the architectural frame of the façade within the painted chapel itself. While these features establish the work's figural presence, it would be a mistake to interpret them as illusory tricks. Importantly, Masaccio differentiates between painted realities in a way that accentuates the work's religious content. He paints the patrons and the skeleton (a *memento mori*) as though they occupy *our* space (that is, the space of the external beholder), a space implied as being 'in front of' the fresco's supporting wall (fig. 9). The intersection is conceived as a threshold

between two coexistent realities, the contemporary spatiotemporal reality of the spectator (which shares aspects of the painted 'reality'), and that of the religious representation, the spiritual realm, lying 'behind' the physical reality of the wall's surface. The painting requires an imaginative engagement consistent with the kind of reciprocity afforded an internal onlooker: 'the function of beholding has already been incorporated into the work itself' (Kemp 1998, p. 181). But this imaginative experience is *overlaid onto the 'real' space in which the external beholder stands*, a space that is in itself specifically religious, indeed ceremonial. The work *functions* within what Kemp terms its 'conditions of access'; as noted earlier, this includes 'the contextual and institutional circumstances in which the work of art appears' (1994, p. 366). That the implied viewer is an external beholder affords something an internal spectator cannot, an embodied awareness of the surrounding architecture, which is drawn into the work's domain. At the same time, the very inaccessibility of the fictive chapel ensures that care is taken 'to put a brake on the observer's illusion of being present'; Masaccio ensures that 'the gradation of reality is made in accordance with the logic of the picture's content' (Sandström 1963, p. 30).

This manipulation of painted realities (or unrealities) is the subject of Sven Sandström's sadly neglected *Levels of Unreality* (1963). Sandström argues that Renaissance artists 'appear to have been clearly conscious of the possibilities inherent in a marked distinction between different parts of a picture, together with the complex interweaving of essentially disparate elements having different degrees of reality' (p. 7). Crucially for the current argument, *Trinity's* painted realities maintain a sharp divide between the parts of the space of representation that the viewer can enter, and the parts to which she is excluded – precisely the kind of distinction illusionistic works seek to overcome.⁷ The external viewer enters into the represented space as an implied presence, but only into that part to which she has been allocated a place: that part of the pictorial world that extends outwards to encompass the real space in which the spectator stands, or (more pertinently) kneels (individually, or as part of a group).

This is not the trivial point it might first appear. It questions assumptions that underlie the excessive emphasis frequently placed on Leon Battista Alberti's so-called 'window figure', where perspective is conceived, as Panofsky urges, as a 'window' through which we see. I have already noted the theoretical implications of this in the previous chapter, with respect to the confusion of pictorial and projection planes.

I believe we are now in a position to rebut David F. Martin's claim, quoted by Hopkins, that 'With a painting the space between us and the canvas is, ideally, an intangible bridge to the painting, for the most part not explicitly entering into our awareness of the painting' (Martin 1976, p. 282, cited in Hopkins 2003, p. 277). The fact that with *Trinity* we are invited to imagine that so much of the painting exists in front of the projection plane suggests, to the contrary, that with such works the space between viewer and painting is activated,



Fig. 10 Johannes Vermeer: *A Lady Writing a Letter* (c. 1665-66), National Gallery of Art, Washington.

albeit within specific constraints. The activation of this space reinforces the fact that we are directly implicated by the work: the inscription above the skeleton reads 'I was once that which you are; and that which I am, you also shall be'.⁸ Mary's 'gesture towards her crucified son explicitly admonishes the spectator to remember for whom the sacrifice was made' (Spike 1996, p. 170). This is an unmediated address that draws upon the viewer's own psychology. Drawn into the space of representation, the imaginative engagements afforded the internal and external spectators fuse into a *single* experience, one in which we are the recipients of the vision before us. Not through illusory means, but with the beholder's imaginative consent, licensed by the work. And as Baxandall has shown, a fifteenth century audience, much better exercised in visualization techniques, would be far more receptive to the notion of an imaginative engagement overlaid onto everyday reality (1988, pp. 45-48).

4.

To draw the threads of the argument together, my contention is that the imagination plays a decisive role in negotiating the spatial and psychological access to a work implying *either* an internal or external spectator. In both cases, it plays a supplementary role to perception. But the imaginative engagement differs with respect to the implied spectator position

relative to the fictional realm. Works implying either an internal or external spectator are completed outside of the represented scene – in Alois Riegl’s terms, they have an *external coherence* (1999).⁹ In the former case, such as with Vermeer’s *A Lady Writing a Letter* (fig. 10), in the National Gallery of Art, Washington, this space is an unrepresented extension of the ‘virtual’ space of the painting; in the latter case, the virtual space itself is conceived as an extension of the ‘real’ space in which the spectator stands, but in a way that simultaneously draws attention to the projection plane as a threshold between coexistent realities. The difference, in this sense, is one of direction. But this is insufficient as it stands: this same distinction might alternatively be described in terms of an internal spectator who ‘enters’ the virtual space, against the notion of part of the virtual world enveloping the ‘real’ space of the beholder. In both instances, the depiction point belongs to the representational space of the painting, but with the latter the space of representation draws the surrounding architecture into its realm, and into the painting’s content.

My position here is consistent with Maynard’s observation that the reason ‘so many perspective pictures do seem to depict their subjects as lying spatially beyond their surfaces ... may not be so much a phenomenon of perspective as it is one of perspective combined with *framing*’ (1996, p. 27). In agreeing with this proposal, I apply it specifically to the relation of the implied spectator to pictorial space. The differences in imaginative engagements directly follow from the distinct ways such works construct the relationship between frame, picture surface and projection plane – and consequently the relationship between fictive scene and implied viewer. This has both spatial *and* temporal implications. With works implying internal spectators, the projection plane is seldom registered, and the depicted scene, by and large, has no spatial relationship with its surface, or with its frame. In terms of the imaginative projection of depth, the picture surface is transparent. By contrast, in works implying external spectators the picture surface generally coincides with the projection plane, although frequently parts of the picture are depicted as being *in front of* the picture surface and frame; while we might imagine away the surface, we do not lose sight of its pictorial significance in separating levels of *unreality*.

These differences arise from wider distinctions in picturing, and hence are applicable beyond the narrow confines of paintings implying spectators as part of their content. One might readily think of Heinrich Wölfflin’s classic formalist distinction between the tectonic and a-tectonic: where the work is constructed just ‘for this frame’, as a ‘self-contained entity’, appropriate for the ceremonial, against the notion of the ‘open’ composition, where ‘the filling has lost touch with the frame’ (1950, p. 125). But what I want to argue in this thesis is that these alternative conceptions of framing have particular repercussions for how a spectator might be engaged. Works implying the presence of a spectator ‘up the stakes’ – with implications not just for Merleau-Ponty’s question of ‘*where* the painting is’, but the related question of where the spectator is relative to the fictive scene.

Further differences emerge between the respective engagements. Works implying an internal spectator are typically smaller paintings, and this issue of scale is not without significance. No longer tied to a particular location, the continuum between pictorial and spectator's space is broken, and the viewer stands in a place other than the space of representation. The pre-existing world inside the frame is separated out from the real world of the beholder, and continues *beyond* the frame. The framing is thus less self-contained: objects are abruptly cut into at the frame's edges, and the positioning of the vanishing point is typically acentric. Such works have an inherent ambiguity as to *where* the 'absent' scene is: despite being painted from a particular point of view. The imaginative engagement lacks spatial or temporal markers relative to the viewer's situation, precisely because the picture surface and frame do not exist for the spectator in the picture: she inhabits the virtual world of the painting, whereas the picture surface and frame belong to the world of the external beholder. In Kemp's terms, they belong to 'the outer and not the inner apparatus of the work of art' (1998, p. 191). The spectator of the picture can either identify with a spectator in the picture, or imagine *herself* engaging with the scene; in both instances the engagement is from the point of view of someone who *already inhabits* the virtual world of the painting.

By contrast, works designed for a particular architectural setting include a 'concrete spatial tie to the location of the image' (Savile 1992, p. 307). They are completed only by the physical presence of an embodied viewer, and as such engage a present tense (the 'here' and 'now'), experienced *in the first person*, and re-enacted with each new arrival. They locate the fictive space in relation to the spectator by drawing attention to the architectural frame as a spatial and temporal marker. The imaginative engagement does not comprise an identification with the anticipated viewer within a self-contained virtual world, but one of imagining away the distinction between real and virtual, while at the same time registering a metaphysical divide. To quote Podro, 'we are invited both to attend to and to imagine away the distinction between real and fictive, the very distinction presupposed in seeing the painting as a representation in the first place' (1998, p. 16).

In such works, the frame (whether painted or real) is conceived as *belonging* to the virtual world, as well as being part of the external spectator's reality. (In *Trinity*, a more radical interpretation might be that the entire fictional chapel functions as a *framing* device for the miraculous appearance of the Trinity – the frame extending deep into the pictorial space.) As such, in sharp contrast to the ambiguous sense of being *elsewhere*, the imagined engagement is situated, juxtaposed with a 'real' situation, whereby the internal and external beholders merge.

Again, some clarification is called for. And here we can call upon Hopkins's own argument with respect to sculpture, where he distinguishes a more 'metaphysical' sense in which 'spaces may be the same, or different', and the more everyday sense of 'same

space' (2003, p. 279). I have already alluded to such a distinction. Consistent with the way Hopkins applies the 'everyday' sense to sculpture, the spectator of *Trinity* shares the space of the painted reality *in front of* the projection plane. But we also share the space of the fictive chapel beyond – it is in this sense of 'same space' (and, one might add, 'same time') that we might claim the virtual space of the chapel as a continuation of the space of the church. However, *Trinity* preserves a metaphysical distinction between different parts of the fictive realm, and allies this distinction to its religious content. As Sandström notes, 'the religious representation demands distance' (1963, p. 92). This structuring of a conflict between everyday and metaphysical senses of how spaces may be continuous, or not, is something while not unique to painting (as my own work, which utilizes film, illustrates), might nevertheless be said to distinguish the phenomenology of representational painting from that of representational sculpture.



2008

MANTLE

Mantle is a variation of *Monochrome Passage*, but unlike the earlier work *Mantle* has an outward manifestation as a plywood structure. This symmetrical structure, 4800mm long, is suspended from above, supported by two steel brackets. As with *Monochrome Passage*, internal stepped passages, 70mm wide, connect the space occupied by the spectator to two openings which receive and diffuse light. Each passage contains seven steps, 70mm high and 210mm long. The internal form is painted a uniform French grey, the external form left unpainted. The outward sculptural form is completely determined by the internal logic of the piece, rather than the demands of its object status. The work might thus be legitimately considered as a three-dimensional painting: a painting which nevertheless envelops the viewer. The shift in scale between external object and interior space is even more marked than in *Monochrome Passage*, and it is difficult to equate the two. Enveloped by the suspended object as s/he peers into the work's inner recesses, the spectator is both made aware of his or her physical presence, but also curiously disembodied by the imaginary engagement with the internal spaces. The experience is not just visual: the acoustics are transformed by the enclosing structure, which might almost be mistaken as some kind of rudimentary yet functional auditory device.

3

Seeing Depth and Nonconceptual Content

The imaginary is much nearer to, and much further away from, the actual – nearer because it is in my body as a diagram of the life of the actual, with all its pulp and carnal obverse exposed to view for the first time ... And the imaginary is much further away from the actual because the painting is an analogue or likeness only according to the body; because it does not offer the mind an occasion to rethink the constitutive relations to things, but rather it offers the *gaze* traces of vision, from the inside, in order that it may espouse them; it gives vision that which clothes it within, the imaginary texture of the real. (Merleau-Ponty 1993c, p. 126)

1.

I began Chapter One with the question of how we see depth in painting, in a representation that, by definition, excludes the third dimension. Following Budd, I argued that a vivid experience of pictorial depth requires an imaginative projection into the marked surface of the depiction. Not a free-floating projection, but one supported and licensed by the contents of the picture. After Merleau-Ponty, I have labelled this engagement *seeing-with*, a seeing according to the picture. In Chapter Two I extended this argument to address the different engagements afforded works implying internal and external spectators, and the role a work's frame plays in structuring such an engagement. In this chapter I will expand this argument to include the role imagination plays in replicating our bodily situatedness in the world when we engage with paintings. Crucially, I will argue that it is imagination that allows our engagement to draw upon nonconceptual content.

An obvious place to begin such a discussion is the situated perception of Merleau-Ponty. But there is a problem in so doing, in that Merleau-Ponty denies an autonomous role for the beholder, rarely referencing 'spectatorship' in painting.¹ This is, at least in part, a tendency to associate the term 'spectator' with a corresponding lack of involvement in a point of view (2002, p. 354). Under the heavy influence of Panofsky's *Perspective as Symbolic Form* (1991), Merleau-Ponty refers to perspectival paintings as remaining at a distance, and hence not involving a viewer (2004, p. 53). And yet there is an inherent contradiction in Merleau-Ponty's position. As Brendan Prendeville notes, the anomaly is that Merleau-Ponty was 'at once a perspectivist and a philosophical critic of perspective': hence 'even the most schematic perspective construction posits the reciprocity of perceiver and perceived ... and in this sense Merleau-Ponty belonged to a tradition that could properly be termed perspectivalist' (1999, p. 366).

Beyond such unease with the terminology, I believe that there are two primary reasons for this surprising omission of a role for the beholder. The first is a consequence of an increasingly radical non-dualism, which refuses to separate the subject from the world that painting presents (Prendeville 1999, p. 366). As Crowther observes, 'Merleau-Ponty's fundamental philosophical premise is that our basic contact with the world is pre-reflective. We operate in and upon the world without making any explicitly conscious differentiation between ourselves as the subject of experience, and the world as the object of it' (1993a, p. 102). If our basic contact with the world is preconceptual in content, this nonconceptual component includes an awareness of our body's positioning in space.

Unlike his contemporary Jean-Paul Sartre, for whom consciousness is conceived as being 'transparent' to itself, for Merleau-Ponty it is opaque (Moreland 1998, p. 16). Merleau-Ponty argues that 'we cannot be transparent to ourselves' because we are *situated* in the world – 'ambiguity remains' (2002, p. 444). If Sartre's dualism prevents a phenomenological reconciliation of object and subject, then, as Leo Rauch notes, 'for Merleau-Ponty, the reconciliation is not only possible, it is constant, ubiquitous' (1998, p. 9). Merleau-Ponty sidesteps Edmund Husserl's subject-object distinction by 'refusing to isolate consciousness from its world: he sees consciousness as already *in* its world' (p. 2). Perception provides our primary relation to a world that consciousness *already* inhabits.

But how is this reciprocity captured by painting? And how does it address painting's two perspectives, that of the fictive scene and that of the real space of the beholder? There is a noticeable shift in Merleau-Ponty's philosophy from an earlier phenomenological approach to situated perception to the radical ontology of *The Visible and the Invisible*, where Merleau-Ponty claims that 'the problems posed in [the *Phenomenology of Perception* (2002)] are insoluble because I start from the "consciousness" – "object" distinction' (Working notes, 1968, p. 200). This shift runs the risk of introducing an ontological monism, with particular consequences for Merleau-Ponty's account of painting; as Galen Johnson notes, 'such a monism would collapse the depth of the world, the *distance* between painter and thing and the movement of things' (1993, p. 47).

Nevertheless, Merleau-Ponty has at his disposal *just* the means to overcome such an ontological monism. Johnson makes this point, when he claims that Merleau-Ponty's introduction of the dual terms 'reversibility' and 'Flesh' puts a break on this perceptual monism, which 'seems in danger of sedimenting and rigidifying into a more basic frozen monistic metaphysic' (1993, p. 47). Johnson argues:

Flesh and reversibility are notions meant to express both envelopment and distance, the paradox of unity at a distance or sameness with difference, finding a new ontological way between monism and dualism. (pp. 47-48)

Merleau-Ponty describes *flesh* as neither matter (the objective body) nor mind (the

body thought): ‘To designate it, we should need the old term “element” ... in the sense of a *general thing*, midway between the spatio-temporal individual and the idea, a sort of incarnate principle that brings a style of being wherever there is a fragment of being’ (1968, p. 139). Crucially, it describes a ‘lived body’, aware of its own reciprocal situatedness in the world: if I see, then another also sees me, as I too am possessed of the visible. This is an intuition he argues is readily understood and exploited by painters. Surrounded by the visible, the body - which both sees and is seen - is ‘a thing among things’: ‘made of the same stuff’, it is ‘caught up in the fabric of the world’ (1993c, p. 125). And yet while in the midst of the visible, ‘the body interposed is not a thing, an interstitial matter, a connective tissue, but a *sensible for itself*’ (1968, p. 135). In what Merleau-Ponty terms ‘reversibility’, the two ‘sides’ of the body - the objective and phenomenal body, the body sensible and the body sentient - are not simply juxtaposed, one against the other (p. 136). Rather, they constitute a reciprocal insertion - an intertwining - where the ‘seer and the visible reciprocate one another and we no longer know which sees and which is seen’ (p. 139).

While this reciprocity is fundamental to his general account of situated perception, Merleau-Ponty fails to apply his notion of reversibility to the kind of imaginative engagement I argue is afforded a situated viewer of painting as an external presence. For all his emphasis on embodied perception, Merleau-Ponty’s radical non-dualism ultimately negates a painting’s beholder as a physical presence considered as separate from the work. This underlies his unease with perspectival representation, and its implication of a beholder position outside of the work. In proposing that ‘the painting is a “world” by opposition to the unique and “real” world’, Merleau-Ponty argues that it is ‘an organized ensemble, which is *closed*, but which, strangely, is representative of all the rest’ (Working notes, 1968, p. 223). This is the second of the two reasons I propose for his effective exclusion of the spectator. Bracketing off a section of reality, the ‘body’s situated negotiation of space’ (Prendeville 1999, p. 366) is *already* encapsulated by the inner framework of painting’s world. This prereflective openness upon the world is conceived as internal to the ‘structure’ of painting conceived in terms of a *symbolic* or *signifying* order.² Merleau-Ponty’s situated and embodied perception is thus prefigured *within* the work. The viewer is already merged with this world: painting presents an undifferentiated mode of viewing where the viewer is not so much excluded (the viewer’s vision is, as it were, merged with that of the painter so that we see ‘according to’ the painting), as denied an autonomous, participatory role.³

This commitment to an essentially closed signifying order, as well as denying an autonomous role for the *external* beholder, arguably rules out the kind of imaginative engagement afforded by Wollheim’s *internal* spectator. As we saw earlier in relation to Damisch, the notion of an internal beholder is fundamentally different to that of an implied subject position. While Merleau-Ponty’s late writings tie the imagination and the seeing of painting very close indeed, it is his underexplained notion of a closed symbolic order,

inherited from Panofsky, which prevents Merleau-Ponty from conceiving of imagination as fulfilling a role not just in terms of the painter's vision, but in the reciprocal insertion between viewer and artwork. And yet, if we conceive of painting's 'structure' not as analogous to language, but as a structuring of our spatial access to the virtual world of the painting (albeit with the viewer's consent), then with certain works our positioning in space, as an *implicit* presence, can form part of the work's content, with all the richness of Merleau-Ponty's notion of the imaginary texture of the real.

2.

Merleau-Ponty's nascent structuralism is difficult to reconcile with his radical empiricism, where, to quote Thomas Baldwin, it is 'our "bodily" intentionality which brings the possibility of meaning into our experience by ensuring that its content, the things presented in experience, are surrounded with references to the past and future, to other places and other things, to human possibilities and situations' (2004, p. 10).⁴ It is Merleau-Ponty's bodily intentionality, its orientation towards the world, that I now want to develop in relation to the seeing of depth. For Merleau-Ponty, the problem of the seeing of depth is that depth is not merely analogous to height or width seen as if from a different angle, but – as 'the most "existential" of all dimensions' – it allows us a prereflective experience of the world (2002, p. 298). It is not an 'objective' property, but something belonging to a situated viewer: depth 'is not impressed upon the object itself, it quite clearly belongs to the perspective and not to things' (p. 298).⁵ Merleau-Ponty develops this point when he states that while breadth can initially pass for a relationship between things 'in which the perceiving subject is not implied', depth 'announces a certain indissoluble link between things and myself' (p. 298). The latter claim stands even when we admit into the account objective properties such as occlusion shape.

For Merleau-Ponty, the enigma of the seeing of depth is that objects eclipse one another in a way that establishes their mutuality of dependence: 'everything is in the same place at the same time, a locality from which height, width and depth are abstracted, a voluminosity we express in a word when we say a thing is *there*' (1993c, p. 140). This has implications for painting. For Merleau-Ponty, pictorial depth is not a case of merely seeing an illusion of depth where clearly there is none, of 'adding one more dimension' to the flat canvas in order to present an illusion that replicates empirical vision (p. 141). Such an illusionist notion fails to capture our bodily situatedness. He argues that the picture is not a device 'borrowed from the real world in order to refer to prosaic things which are absent' (p. 126): the scene that painting presents does not belong to the world - the in-itself - any more than an imagined object does. What this suggests is that it has its own phenomenology, distinct from face-to-face seeing. Rather than replicate empirical vision:

Ultimately the painting relates to nothing at all among experienced things unless it is first of all “autofigurative.” It is a spectacle of something only by being a “spectacle of nothing,” by breaking the “skin of things” to show how the things became things, how the world becomes world. (p. 141)

Crowther interprets ‘this characteristically cryptic passage’ as suggesting that for Merleau-Ponty ‘what a painting makes visible first and foremost are *the conditions of its own visibility*’ (1993a, p. 111). Painting reveals how things disclose themselves, how things become visible, how ‘space unfolds from within’ (Prendeville 1999, p. 364).

In so doing, Merleau-Ponty believes that certain painters, such as Cézanne, are capable of revealing what he terms the transcendence of objects. In the *Phenomenology of Perception*, Merleau-Ponty claims that seeing involves a visual awareness that exceeds what is presented to the eyes from any particular point of view:

To see is to enter a universe of beings which *display themselves*, and they would not do this if they could not be hidden behind each other or behind me. In other words: to look at an object is to inhabit it, and from this habitation to grasp all things in terms of the aspect which they present to it. But in so far as I see those things too, they remain abodes open to my gaze, and, being potentially lodged in them, I already perceive from various angles the central object of my present vision. Thus every object is the mirror of all others. When I look at the lamp on my table, I attribute to it not only the qualities visible from where I am, but also those which the chimney, the walls, the table can ‘see’; but [the] back of my lamp is nothing but the face which it ‘shows’ to the chimney. I can therefore see an object in so far as objects form a system or a world, and in so far as each one treats the others round it as spectators of its hidden aspects and as guarantee of the permanence of those aspects. (2002, p. 79)

Obviously, Merleau-Ponty is not literally claiming here that objects ‘see’. Rather, this ‘positing of the object’ as transcendent is precisely because it ‘makes us go beyond the limits of our actual experience’ (p. 81). The seeing of an object transcends the limitations of our particular point of view, in that it incorporates the ‘visual’ experience of perceiving hidden aspects of the object. This needs some clarification.

3.

Perhaps the most persuasive attempt to get to grips with this elusive passage is Kelly’s ‘Seeing Things in Merleau-Ponty’ (2005). Kelly argues that for Merleau-Ponty the experience of an object’s hidden side is not indeterminate because ‘we have not yet determined perceptually what its determinate features are’, but rather because perception itself is indeterminate ‘because it is essentially *normative*’ (pp. 96-97). It is not a case of simply having yet to view the lamp from the point of view of the chimney, but that *any* point of view is made in relation to a ‘view from everywhere’, a notional (and hence impossible) view that serves as a norm against which any particular perspective stands (p. 95). Thus if the world is *described* by determinate data, with perception ‘we are constantly sensitive

not only to what we perceive but also, and essentially, to *how well* our experience measures up to ... norms about how best to see the thing perceived' (p. 97). Kelly argues that unlike Husserl's account of this problem, where the fully-fledged three-dimensional experience of an object 'comprises the sum of all the possible perspectives that I could have on it' (p. 98),⁶ for Merleau-Ponty the experience is one where "I already perceive" the hidden side of the object because I am "potentially lodged in" the background object that now stands behind the figure' (p. 99). In order to make sense of this claim, Kelly makes an analogy to Merleau-Ponty's account of motor intentionality, the unreflective bodily awareness involved in, for instance, grasping an object such as a coffee mug (p. 99).⁷ Thus Kelly argues:

This kind of full bodily readiness for something is what I believe Merleau-Ponty is pointing to when he says that I am now 'potentially lodged in' the other points of view on the object. It is not a matter of now having a determinate experience of what is seen from those points of view, any more than the motor-intentional understanding of the mug is a matter of having a determinate visual experience of its features. Rather, it is a kind of bodily readiness to take up those points of view, a readiness that is reducible neither to a determinate cognitive understanding of what is seen in the view⁸ nor to a series of merely reflexive bodily movements. (p. 100)

If Kelly is right to interpret Merleau-Ponty's position this way, then this notion of 'bodily readiness' also has important implications for Merleau-Ponty's account of painting. Kelly argues that the problem of object transcendence 'poses itself most forcefully when we acknowledge the phenomenological distinction between experiencing something as a mere two-dimensional façade and experiencing it as a full three-dimensional entity' (p. 77). He uses the example of how the experience of perceiving a film set might radically change once it is exposed as a series of shallow façades, despite the fact that the information projected onto the retina remains the same. The experience will seem less replete, precisely because there are no hidden aspects to reveal. While Kelly does not relate this argument specifically to painting, clearly it has a bearing on the current argument, in that Merleau-Ponty insists that painting captures a sense of object transcendence, denied the two-dimensional film set. This might appear to be an anomaly, and once again returns us full circle to the question of how the loss of the third dimension is overcome in painting. How can, as Merleau-Ponty claims, painting extend to all aspects of Being the distinctive aspect of vision, 'that to see is *to have at a distance*' (1968, p. 127), when painting specifically *excludes* the third dimension?

Crucially, in 'Eye and Mind' Merleau-Ponty claims that 'painting is an analogue or likeness only according to the body', whereby 'it gives vision that which clothes it within, the imaginary texture of the real' (1993c, p. 126). The relationship between imagination and the body is held to be key. Unlike the role Merleau-Ponty assigns imagination in the *Phenomenology of Perception* (2002), where, influenced by Sartre (1972)⁹, imagination is

still characterized by its 'essential poverty', works such as 'Eye and Mind' (1993c) and *The Visible and the Invisible* (1968) come to a renewed understanding of the relationship between imagination and embodied perception: and, notably, imagination and painting. If, for Merleau-Ponty, we 'see according to, or with' the painted image, then this is only because the imaginary 'is in my body as a diagram of the life of the actual' (1993c, p. 126). As a diagram of the life of the actual, it is the imagination, I would suggest, that replicates an experience of object transcendence in painting; imagination, grounded in the reciprocity of our bodily experience of the world through a shared bodily frame of reference, invokes a nonconceptual or prereflective bodily readiness.

It is imagination's role in replicating a bodily readiness toward the world that gives painting the capacity to capture things at a distance in a fully three-dimensional way, what Merleau-Ponty refers to as a 'proximity through distance' (1968, p. 128). This perhaps comes closest to Merleau-Ponty's notion of how space unfolds in painting, for depth reveals not only how things envelop each other (the adding of one more dimension to the picture surface), but how such enveloping forms a 'system' or 'world', the content of which exceeds the limits of what painting represents. It is the role imagination plays in fully experiencing a potential to be lodged in the various possible viewpoints of the virtual space of painting that provides painting with a transcendence characterized by Merleau-Ponty as 'being-at-a-distance' (Working notes, 1968, p. 208).

If we relieve Merleau-Ponty's account from its commitment to a symbolic order, we can start to fully recognize something implicit but unregistered in his account: that situated perception also posits a beholder, something fundamental to Merleau-Ponty's account of ordinary perception, where - as we have already noted - he argues that depth 'announces a certain indissoluble link between things and myself' (2002, p. 298). At least with certain works, we can then break through painting's supposed closed world, *not* in a way that replicates ordinary vision, but in a way that - through sustained viewing - exploits our bodily readiness towards the world. And it is crucial to my argument that it is this *bodily readiness* that is activated by works engaging the external beholder as part of their content. While this may not be the full kinetic potential of sculpture, it exceeds the mere 'vivid' experience of pictorial space. And in works where the internal and external spectators fuse, it draws upon an awareness of our positioning in 'real' space.

4.

Kelly's interpretation of Merleau-Ponty's position can, I believe, refine a similar notion of the role of imagination in painting made by Crowther. As a prominent advocate of Merleau-Ponty's philosophy, Crowther also holds 'we *inhere* in the sensible' (1993a, p. 1), and that the artwork '*reflects* our mode of embodied inherence in the world' (p. 7). Crowther argues that Merleau-Ponty's nonconceptual contact with the world 'involves a primordial awareness

of our body's positioning and its unity - an awareness which articulates the world into an intelligible schema' (p. 103). It is a synaesthetic contact which does not distinguish between the visual and tactile (p. 107), and provides 'a kind of ontological reference point ... on the basis of which the body is able to orientate itself appropriately towards the world' (p. 106). The concreteness of this ontological reciprocity is experienced through art. For Crowther, art is a process of constructing what he calls 'sensuous manifolds'; in a 'symbolically significant' sensuous manifold it is the 'integral fusion of the sensuous and the conceptual which enables art to express something of the depth and richness of body-hold in a way which eludes modes of abstract thought' (p. 5).

Now while I am unsure about aspects of the terminology, Crowther's account does seem to capture something of the interlock between conceptual and nonconceptual orientations towards the work. Crowther also argues that imagination plays a pivotal role in our experience of painting. In particular, he assigns the imagination a specific role in perspectival works. In his chapter on 'The Objective Significance of Perspective' in *The Transhistorical Image* (2002, ch. 3), Crowther notes that:

[O]n the one hand perspective articulates an objective order of relations, with which the viewing subject is continuous but which fixes him or her in a definite position. The subject is located as an element within a spatial system. The distance of objects from such an ideal viewer is rigidly articulated. On the other hand, however, perspective is at the same time a means whereby the viewer assimilates and controls space by articulating it in symbolic terms. It becomes thereby a kind of extension of the imagination. The viewer is, in a sense, merged with the world. (pp. 45-46)

In putting forward a more favourable appraisal of Renaissance perspective than Merleau-Ponty, Crowther here recognises a distinction between a viewer 'merged' with the virtual world of painting and an 'objective order of relations', where the spectator is continuous with, but also distanced from, the spatial system of painting.

Following both Panofsky and Merleau-Ponty, Crowther considers perspective as a symbolic form. Crowther notes that the fact that perspective is 'articulated from a two-dimensional base explicitly characterizes it as an "image of" some possible kind of visual state of affairs other than itself' (p. 55). It has, as we have already noted, a double aspect. Moreover, for Crowther perspective has a privileged role in terms of symbolic form in that 'to recognize a picture as an image of a specific kind of thing involves a tacit reference of the thing depicted to a virtual counterpart of the latent schema that might surround an actual thing of that kind' (p. 57). This implies a functional unity of time and space: a 'virtual spatial structure' and 'a unified order of temporal continuity', where, crucially, 'for this explicit level to be reached, it is necessary that the thing be presented in relation to other things in a way that implies a *continuous* unfolding of possible viewpoints' (p. 57). This is a direct reference to Merleau-Ponty's observation that the object of perception

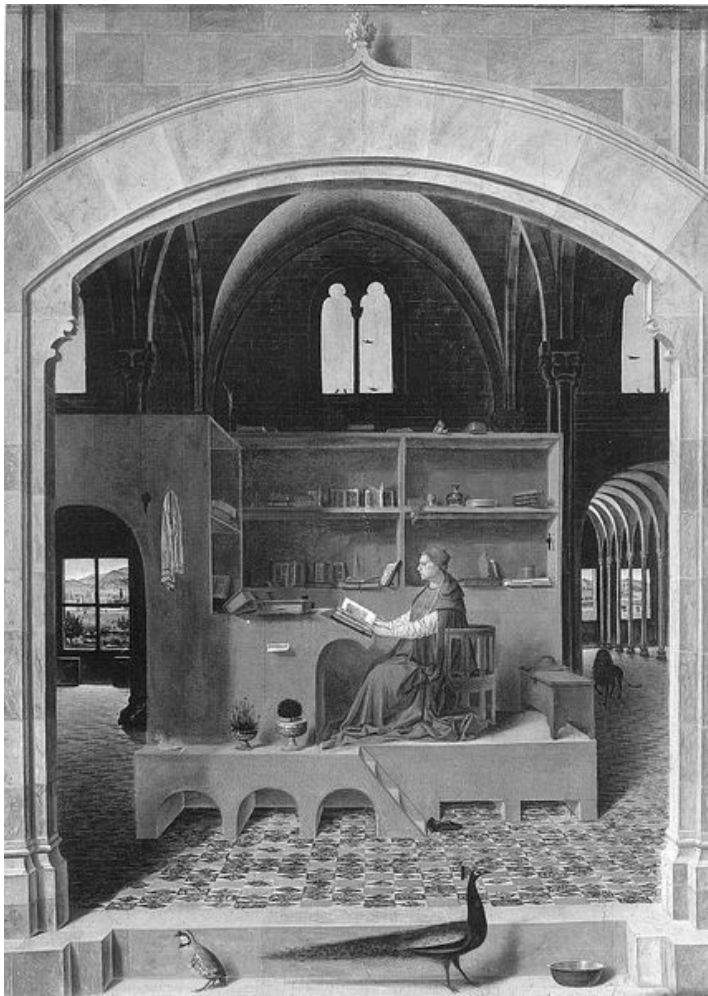

Fig. 11 Antonello da Messina: *St Jerome* (c. 1450-55), National Gallery, London.

is a 'totality open to an horizon of an indefinite number of perspectival views' (1964, p. 16). Thus, in relation to Antonello da Messina's *St Jerome* (fig. 11), in London's National Gallery, Crowther maintains:

One could view the saint, for example, from a position behind the left pillar of the door arch by *moving into* that position. From here one could construct an image with the saint viewed under a more frontal and elevated aspect. A movement further to the left would make the saint even more frontal, but now partially obscured by the large wooden cabinet. And so on and so on. Now the point is, that this virtual space is one which in imaginative terms we can traverse continuously by changing our spatiotemporal position. Each change of viewpoint would be co-ordinated with the rest. It is this unity of the spatiotemporal continuum that perspective is able to articulate in its projection from two dimensions. (2002, p. 58)¹⁰

The free-floating nature of such imaginings is perhaps problematic. But if we accept Kelly's interpretation of Merleau-Ponty's position, then we might acknowledge that we are already 'potentially lodged in' these other viewpoints; the role of imagination is not, necessarily, to move us into that position. Rather, imagination accesses our bodily readiness, in a way by which these alternative viewpoints can be said to be *already perceived*. They are

implicit within the painter's point of view. Merleau-Ponty claims that certain painters are able to capture this potentiality. But I would argue that painting also affords an imaginative engagement with a corresponding potential for a reciprocal insertion between viewer and artwork.

5.

I have argued that Merleau-Ponty's question of '*where* the painting is' is only really intelligible with respect to an imaginative engagement with painting, and it is here that Merleau-Ponty's account can offer something more substantial to the limited notion of imagination providing a 'vivid' experience of pictorial depth. If, as Budd suggests, the imagination is essential for the richer experience of pictorial depth, then I would contend that it is also essential for the kind of reciprocity Merleau-Ponty argues is implied by painting. This reciprocity arises from a nonconceptual bodily awareness of depth, which, as we have seen, can encompass the possibility that we are already potentially lodged in alternative viewpoints; but equally, it might imply the kind of reciprocity of content that Merleau-Ponty downplays, where we interact with the painting's narrative content as an implied spectator.

I am not here attempting a *systematic* reconciliation of Merleau-Ponty's ontological position with analytic derived accounts of depiction.¹¹ Such a project would be problematic, not least given the radically different styles of argument. Nevertheless, there are clear parallels between analytic attempts to construct a bodily frame of reference and Merleau-Ponty's notion that the spatiality of my body 'is not, like that of external objects or like that of "spatial sensations", a *spatiality of position*, but a *spatiality of situation*' (pp. 114-115).

Peacocke's *A Study of Concepts* (1992), for instance, uses the term *positioned scenario* in relation to 'nonconceptual representational contents' (p. 97), which he argues a perceptual concept must possess.¹² While Peacocke's *scenario content* is not given the ontological significance of Merleau-Ponty's use of 'prereflective', both philosophers hold that perception has a nonconceptual component. In a clear echo of Merleau-Ponty, Peacocke argues that a positioned scenario draws upon the experience of the body as its frame of reference, a constant that has a direct parallel with (and constitutes a disposition towards) bodily actions (p. 94). This bodily frame of reference remains constant, regardless of location: it is part of a subject's 'building up a consistent representation of the world around him and his location in it' (p. 91). Peacocke argues:

In supplying a subject with information about the location of things relative to bodily axes, perception supplies that nonconceptual information in a form immediately usable if the subject wants to move his body or some limb toward, from, or in some other spatial relation to what he perceives. (p. 93)¹³

One of the strengths of Peacocke's theory is that it integrates spatial and temporal

markers. Peacocke defines a positioned scenario thus:

A positioned scenario consists of a scenario, together with (1) an assignment to the labeled axes and origins of the scenario of real directions and places in the world that fall under the labels, and (2) an assigned time. For a particular perceptual experience, the real directions and places assigned at (1) are given by the application of the labels to the subject who has the experience. If the origin is labeled as the center of gravity of the body, the real place assigned to it is the center of gravity of the perceiver's body, and so forth. (I oversimplify a little in aiming to capture the spirit of a position.) The time assigned at (2) is the time at which the perceptual experience occurs: perceptual experience has a present-tense content. We can then say that the content given by the positional scenario is correct if the scene at its assigned place falls under the scenario at the assigned time, when the scenario is positioned there in accordance with the assigned directions. (pp. 64-65)

Peacocke notes that two advantages of his thesis are that (i) it captures a central aspect of visual experience, that 'an experience can have a finer-grained content than that formulated by using concepts possessed by the experiencer' (p. 67),¹⁴ and (ii) a situated scenario allows for 'overlapping contents of experience in different sense modalities' (p. 69). Moreover, Peacocke makes the crucial point that 'the fact that a concept is used in fixing the scenario does *not* entail that the concept itself is somehow a component of the representational content of the experience, nor that the concept must be possessed by the experiencer' (p. 68). This directly follows from the fact that the assignment of labelled axes is not 'a purely notational or conventional matter', but it 'captures distinctions in the phenomenology of experience itself' (p. 62). The positioned scenario *is* the content of the experience: 'it is to be distinguished from any mental representation of the content' (p. 65). A scenario is a 'spatial type', and Peacocke distinguishes a spatial type from a concept (p. 67).

Despite differences in the use of language, there is thus a direct parallel between Peacocke's notion of a positioned scenario providing a bodily frame of reference used for spatial reasoning and action, and Merleau-Ponty's anchoring of a body in terms of a 'situation': where 'it is clearly in action that the spatiality of our body is brought into being' (2002, p. 117), so that 'the body image is finally a way of stating that my body is in-the-world' (p. 115). Both emphasize the phenomenal body rather than a set of axes coordinates in objective space. And just as Peacocke makes a clear distinction between a positioned scenario and any mental representation of such a content, Merleau-Ponty notes:

The space in which normal imitation operates is not, as opposed to concrete space with its absolute locations, an 'objective space' or a 'representative space' based on an act of thought. It is already built into my bodily structure, and is its inseparable correlative ... for us to be able to conceive space, it is in the first place necessary that we should have been thrust into it by our body ...' (p. 164)

6.

How does the significance of such a bodily structure or frame of reference input upon my case for a specific role for the imagination in what I have termed *seeing-with*? I have argued that this role encompasses both our spatial and psychological access to a work. While supplementary to perception, it *is* necessary for the reciprocal relationship implied by works having an external coherence: works where the content is completed by the presence of a beholder, whether an internal or external spectator. The imagination is called upon because perception, unaided, is inadequate for experiencing such works, as their representational content exceeds what they represent within the bounds of the fictive scene. The imagination provides what the work cannot, directly, represent: the absent viewer. The reciprocity of seer/seen depends upon the viewer either identifying with an unrepresented figure within the work (whether conceived in Hopkins's or Wollheim's terms), or imaginatively experiencing the work *in the first person* from the perspective of the external beholder, fused with the internal spectator. These differences arise from distinct relationships between frame, projection plane, picture surface and scale.

I began the previous chapter by disputing Hopkins's claim that painting must always present a self-contained world. And yet, Hopkins's final chapter on visualization in *Picture, Image and Experience* provides at least part of my argument for doing so (1998, pp. 159-200). Hopkins notes that there are overlaps between the contents of vision, visualizing, and seeing-in. All three present us with objects that are similarly represented 'in a distinctive perspective': they are all perspectival, in that there is always some point from which they are presented (p. 197). This shared perspective withstands the fact that with visualization this 'point to which the object is orientated need not be very determinate at all' (p. 171). This has parallels with Peacocke's argument that not only can a positioned scenario provide a content for a fully perceptual experience, but it can equally give the content of nonperceptual experiences, although such cases 'have to be elucidated by the relations in which they stand to the fully perceptual case' (1992, p. 67). If visualization, like ordinary vision and seeing-in, is essentially perspectival, then the role I assign it in representational seeing is similarly elucidated by its relation to the fully perceptual case.

In order to make sense of the distinctions between vision, visualizing and seeing-in, Hopkins introduces his own notion of a spatial 'frame of reference', which has obvious parallels with Peacocke's scenario content. Hopkins argues that 'vision supports a distinctive frame of reference on the space it represents', a frame of reference which is deictic:

The notions *nearer, farther, in front of* and *occluding* allow us to identify positions along 'lines of sight', lines from the fulcral point to points in represented space. Other notions let us pick out such lines of sight, identifying them by their relations to others - *right, left, up* and *down* are examples. We might call this the 'sightline' frame of reference. (1998, pp. 185-186)

Given that visualization, seeing-in and vision share a common means of representing space, Hopkins argues that visualization and seeing-in must also share this distinctive frame of reference; they share the contents of vision, and 'the structure within which it represents space' (p. 184). But there are crucial distinctions.

In vision, the frame of reference 'controls action immediately', whereas 'the frame of reference on the imagined world, although again constituted by the sightline notions, never guides action in this way' (p. 186). Hopkins claims that this explains part of their phenomenological difference. The perspectival frame of seeing-in can also guide action, such as when, without reflection, we point towards a figure within the depicted space (p. 196). But seeing-in is distinguished from both vision and visualization in that it presents two perspectives, that of the painting as object and that of the depicted scene. As Hopkins notes, 'although seeing-in displays the same sort of perspective as visualizing, it differs from it in exhibiting it, as it were, twice over': in so doing, 'it is a way of seeing something, the marked surface, while visualizing is not' (p. 197).

While I agree with all of the above (with one qualification), it fails to adequately address how the imagination can expand what can be experienced in a painting, in terms of an implied reciprocity between viewer and work that draws upon scenario content. This has particular relevance to the question as to 'where the painting is I am looking at'. I have argued that the question has little relevance to the mere recognition of distance cues presented by the marked surface. It is only when, through an act of will, we transform such cues into an *imagined* third dimension that the question becomes pressing; in particular, it raises the related question of the spectator's positioning relative to such an implied space. And here I would argue that my distinction between the imaginative engagements implied by the internal and external spectator mirrors an important distinction between two types of visualization: when objects are presented as *absent* or *elsewhere*, and instances when they are not. Most visualizing, while sharing vision's frame of reference (in that it shares sightline notions), retains a considerable ambiguity or indeterminacy as to *where* the objects of the imagining are. This ambiguity is replicated by the imaginative engagement afforded an internal spectator or onlooker, when the marked surface 'disappears'. While we can effectively point to things within the depicted scene, our location within the self-contained virtual world lacks specific spatial markers as to how such depicted objects stand in relation to the spectator *of* the picture. The imaginative engagement draws upon our experience of scenario content *relative* to the fully perceptual case, independently from our actual location.

However, as Hopkins concedes, 'at least some visualizing will exhibit precisely the feature we are supposing to be, in part, definitive of seeing - representing space from a point within it, myself as occupying that point, and, therefore, the space as *before me*'

(1998, p. 185). Hopkins offers the example of when we close our eyes before an object and continue to imagine the same object in front of us. A more pertinent example might be a kind of situated visualizing that I am very familiar with. I frequently imagine my sculptural constructions *as if before me*, in the space of the gallery in which the work is to be installed. Here, the visualization is overlaid onto a face-to-face encounter with a real space; it is an imaginative experience where, walking *and* visualizing, I use my body as a kind of datum, to the extent that I am able to make very precise decisions about scale and relative position, something that is impossible to do when I imagine the installation remotely with my eyes shut. In such situated imaginings, visualization *can* guide action, albeit action that is mediated by the physical experience of the gallery space itself.¹⁵ It can guide action because there is an overlap of frames of reference, and of scenario content.

I would argue that this combination of seeing and visualizing is analogous to the kind of imagining involved when the internal and external beholders merge: where the imagining of pictorial depth is overlaid onto a 'real' situation, and we imagine away the distinction between fictive and real. Here our bodies act as a datum for the fictional space, both in terms of scale and orientation. The imagination permeates perception, to the extent that while it might not guide a full kinetic potential for action, in that painting presents its virtual space frontally, it nevertheless draws something of the surrounding space into the work's content. I am now in a position to refine this claim. I am not here claiming that non-inferential control is present (this is an imaginary, not an illusory experience, and is not dictated by the need for a fixed viewpoint), but that paintings *can* be experienced in the light of such a kinetic potential: not in terms of activating our space as Langer (1953) argues is the case with sculpture, *but through the role imagination plays in the potential to be lodged in other points of view*.



CHAMBER

2005

Chamber is a work constructed using white painted canvas stretchers, with the backs of the stretchers facing outwards towards the gallery space. This is not so much a reference to painting, as an intention to construct an enclosed structure that nevertheless admits a soft, diffused light. The viewer is restricted to a very narrow entrance, 1800mm high and 600mm wide, the dimensions of which confine and locate the body. From this position, the viewer can look down at - but not descend - a strangely scale-less flight of stairs, leading to the flooded floor of the 'chamber' beyond, a space that is 3000 x 1200mm and 2000mm high. The structure houses a video projector, framing the projection onto the rear wall of a looped film, where a back-lit wall slowly recedes into the distance until it fades into pure light. The film is cropped so that the vanishing point of the film corresponds to the viewer's eye-height: the projected space thus appears to extend the dimensions of the physical space itself. However, the illusion is contradicted by the projection's reflection in the water-filled floor, which both reveals its status as a two-dimensional image, and opens up a second vanishing point which continues the descent of the steps. Chamber thus presents two vanishing points. While locating a viewer as a physical presence, it presents a space which cannot be entered.

4

Two Modes of Situated Relationship

Paintings address us, and they do so in part through creating uncertainty; our engagement with them involves a continuous adjustment as we scan them for suggestions on how to proceed and for confirmation or disconfirmation of our response. (Podro 1998, p. vii)

1.

In the opening three chapters, I set out a philosophical argument for an expanded role for the imagination in how we might negotiate painting's two perspectives. Crucially, in Chapter Two I argued a particular role for the imagination in works implying an external coherence. Such works are completed by the imagined presence (or sometimes a 'felt' absence) of a spectator, whether this beholder is conceived as internal to the painting's fictional world, or where the representational space extends outwards to encompass the real space in which the external spectator stands. Whereas the imaginative engagement provided by an internal spectator renders the picture plane transparent, in works integrated into their architectural contexts the frame and supporting wall function as spatial and temporal markers that register our location in front of the work. I have argued that in both instances the beholder is an implicit presence: to again use Kemp's phrase, 'the function of beholding has already been incorporated into the work itself' (1998, p. 181). My position is close to Podro, who argues that these are works where 'we feel the fit between our position and the picture, a fit that enables us to include our orientation in imagining the subject' (1998, p. 64). As noted in the previous chapter, this orientation arises from (and is made more replete by) shared frames of reference between vision, seeing-in and visualization.

In this chapter I aim to concretize the argument through specific examples of artworks. In so doing, I draw upon a rich seam of art historical writing on painting and spectatorship. The aim is not to survey such writing, but to test the philosophical position against individual artworks and aspects of their art historical literature. I will focus the discussion upon examples predominantly drawn from two types of works: (i) Italian Renaissance altarpieces, integrated into their architectural contexts; and (ii) Dutch genre paintings, that alternately register or deny the presence of an internal spectator. In so doing, I also address some works that construct a tension between (rather than merging of) the modes of engagement implied by internal and external beholders.

My intention is to describe two distinct modes of spectatorship, what Kemp refers

to as *conditions of appearance* or *conditions of access* (1998, p. 186). To co-opt Podro into my argument, with the first mode 'the play between the orientation to the surface and to the subject might be thought to be dependent on an architectural setting determining the real spatial relation to the viewer' (1998, p. 64). By contrast, works implying internal spectators are more open-ended in terms of their situated reception: they are not tied to a specific location, although they do structure an implied relationship to a beholder, but one that is internal to their virtual world. Unlike the first type of relationship, the beholder is not situated by extrinsic conditions.¹

I do not claim these situated relationships as overarching art historical 'categories', and the examples I employ are by no means representative of *all* works implying such spectators. Nor do I intend to imply that the shift from external to internal spectatorship represents a stylistic 'progression'. The relationships I describe are best seen as tendencies, and as such they cut across art historical periods; they are 'functional' dispositions rather than 'formal' categories, in that, through perspective and framing, they *structure* a relationship between viewer and painting, rather than constitute formal attributes of the work itself. Having said this, they share features of wider 'formal' categories such as Wölfflin's distinction between the *tectonic* and *a-tectonic* (1950, ch. III). They also correlate to aspects of the classic distinction between Italian and Northern painting.² While I am not making any great claim for originality in terms of describing the relationships, I believe I frame the distinction in an original way by defining them functionally according to their different conditions of access, and by highlighting the role that the imagination plays in structuring their reception, in what I have termed a *seeing-with*.

2.

I summarise below key attributes typical of works that engage an external beholder through an integration of the painting into its architectural context. Giovanni Bellini's *San Zaccaria Altarpiece* (fig. 12) might serve by way of example:³

- (a) Such works are integrated into their spatial setting, typically by incorporating the work's frame, whether painted or three-dimensional, into both the fictional world and the architectural schema of the church.
- (b) The work is conceived as a self-contained entity, typically an 'illusory' chapel, spatially and temporally consistent with its setting, rather than representing a prior world that continues beyond the frame.⁴
- (c) Approached processionally, the paintings are locked into their institutional contexts, with all the corresponding 'ritual behaviour' that accompanies such a conventionalised setting. The space the viewer occupies is thus *already* sanctified, differentiated from ordinary, everyday space; the viewer is thus primed by certain



Fig. 12 Giovanni Bellini: *Virgin and Child Enthroned with Saints* (*San Zaccaria Altarpiece*) (1505), San Zaccaria, Venice.

expectations as to the work's content.

- (d) Such works generally contain a mediating figure(s), who, directly acknowledges the presence of the spectator (more specifically, the *external* beholder) by a gesture, or 'look'.⁵ (In Bellini's altarpiece it is the musical angel, sat at the feet of Mary and Christ, who holds our gaze.)
- (e) The scale of the representational space is consistent with, and taken from, the bodily scale of the viewer, imparting a strong sense of physical presence.
- (f) The vanishing point (or, more precisely, the centric point)⁶ is placed at *approximately* the viewer's eye level, and the painting coheres around a position directly opposite this point.
- (g) Elements of the painting encroach upon the spectator's space, painted as if they are 'in front of' the fresco or panel's supporting surface. (While this is not the case with

the Bellini, the three-dimensional nature of the stone frame produces an equivalent suggestion of spatial continuity.)

- (h) The intersection is conceived as coincident with the supporting wall/panel, constituting a threshold – signalled by the frame – between coexistent realms. As Rona Goffen notes in relation to Masaccio's *Trinity* (fig. 2): 'the frame is understood both as the terminus of the fictive architecture and also as the point (or plane) where the two worlds, sacred and mundane, meet and coincide' (1986, p. 40).
- (i) Despite establishing a spatial continuity, the siting of the work (often with a low centric point relative to the figures) places limits on our implied participation, respecting the separation of spiritual and earthly realms.

3.

Bryson's *Vision and Painting* (1983) offers a similar distinction between what he regards as the first (Albertian) and second (culminatory) epochs of perspective (ch. 5). There is an overlap between Bryson's categories and the situated relationships I describe, despite differences in our respective interpretation of these distinct modes of viewing. Bryson refers to works from the first epoch of perspective as *advertent* (i.e. 'fully aware of an unseen witness'), where 'the body of the viewer is positioned *processionally*' (p. 111). Bryson uses Masaccio's *Trinity* as an example, a work that I have already noted as fundamental to my own position. He observes in *Trinity* many of the aspects that I have argued are particular to works fully integrated into their architectural context: (i) the represented figures are life-size; (ii) the vanishing point is at eye-level; (iii) the painting coheres around this point; (iv) the implied ground plan of the painted space is continuous with that of the spectator's space; and (v) the vanishing point is placed 'unnaturally' low relative to the figures within the work, so that the scale, while lifelike, seems nevertheless monumental (p. 108). Bryson notes:

These spatial effects assume the viewing subject as an actual bodily presence, reacting to scale within the image as though to the scale of normal experience: the vocative address of the image is directly somatic. (p. 108)

Yet for Bryson this physical embodiment of a viewer in the first epoch of perspective is a curious anomaly, the failure to resolve the theoretical implications of Albertian perspective. Bryson maintains that Alberti's conception of the viewing subject is already Cartesian 'in its reduction of the space of painting to dimensionless punctuality' (p. 104).⁷ He thus argues:

There can be little doubt that in its theoretical form, as presented by *De Pictura*, this is indeed the reduction Alberti intends: the eye of the viewer is to take up a position in relation to the scene that is

identical to the position originally occupied by the painter, as though both painter and viewer looked through the same viewfinder on to a world unified spatially around the centric ray, the line running from viewpoint to vanishing point ... Yet curiously, the construction of a punctual and disembodied subject is precisely what painting organised around a single vanishing point fails to achieve. (p. 104)

That *Trinity* produces an embodied beholder is an anomaly only if one accepts Bryson's excessive emphasis on the theoretical implications of the apex of Alberti's visual pyramid, a point in space corresponding to a kind of disembodied eye. I do not have space to fully address this issue, but I will briefly set out certain differences in approach. Following James Ackerman (1991a), I believe it is the conception of the picture as an intersection of the visual pyramid that represents Alberti's key theoretical insight, rather than the notion of a fixed point, a 'dimensionless punctuality', located in the eye.⁸ It is the correlation of intersection and picture surface in works such as *Trinity* that offers the possibility of structuring a relationship between work and an external spectator. This is an important distinction, in that while perspective, combined with framing, locates a spectator, it does not necessarily do so with the kind of precision implied by Bryson. As James Elkins notes, 'we have grown accustomed to thinking of the center of projection as a thing that can be constructed from the painting, "swung out" from the distance point so it hangs in the air like a marker at the end of a thread'; and yet this was not how the Renaissance conceived this point: rather, 'for the Renaissance workers, the principal point was *in* the painting, even if some knew what it signified in space' (Elkins 1994, p. 143).

Given what Puttfarken refers to as the 'permanency of aspect', the 'unchangeable relationship of all parts of the picture to each other', the position we adopt relative to the painting allows for considerable deviation from the position immediately opposite the centric ray (2000, p. 22).⁹ For works integrated into their architectural contexts, what is more important than the beholder taking up the precise position of the painting's depiction point is the correlation of intersection with the painting's supporting wall or panel – in such a way that there is a correspondence between the parts of the picture we are allowed to 'enter', depicted as being *in front of* the intersection, and the physical presence of the wall which defines the limit of our participation. Far from an anomaly, this structuring of a bodily presence is implicit to such a situated perspectival construction; Masaccio's great insight is to utilize this metaphysical divide in a way that dramatizes the work's religious content, differentiating between what is depicted as being *in front of* or *behind* the picture plane.

4.

This structuring of the spectator's implied access is a major concern of two of the key works on Renaissance spectatorship - Sandström's *Levels of Unreality* (1963) and John Shearman's

Only Connect ... (1992). Sandström distinguishes his position from formalist accounts such as Wölfflin's by stating that the 'concepts "degrees of reality" and "planes of reality" are here set in relation with the *functions* of a work of art, instead of being associated with the enduring *properties* or *qualities* of the painting' (1963, p. 10). As such, my own position closely follows Sandström's example.¹⁰ For Sandström, what is important is the 'interplay of forms', which is itself dependent upon the functions such forms have been assigned in the relationship between the picture and spectator (p. 10). To repeat a quote used earlier:

The artists of the Renaissance appear to have been clearly conscious of the possibilities inherent in a marked distinction between different parts of a picture, together with the complex interweaving of essentially disparate elements having different degrees of reality, and the confrontation between on the one hand the picture in its several parts, and on the other the highly concrete reality of the space in which the observer stands. (p. 7)

Of course, in addressing a work's 'degrees of reality', the 'graduation does not, of course, concern reality', rather 'the total unreality characteristic of the forms and objects which the picture seeks to render credible' (p. 7). This manipulating of levels of unreality is particularly acute with mural painting, a situated pictorial art where the normally irreconcilable 'space of a painting' and the 'space of architecture' are often directly juxtaposed: where the threshold separating the 'real' and the 'unreal' quite naturally becomes part of a work's content (p. 16). Sandström observes that:

By locating his pictures at a certain depth inside the surface of the wall, the artist can cause the *objective* pictorial space in front of the depicted scene itself to have the effect of being a direct continuation of the real room in which the observer is standing. In this way the only firm frontier between the sphere of reality and that of fiction is abolished – of course, with the observer's sanction – and by means of rigidly established proportions and relationships, the artist can set to work building up an illusory reality, in which shapes and forms seem sometimes to protrude into real space, sometimes to exist in a continuation of this beyond the surface of the wall. (p. 22)

In a refinement of Sandström's position, I have been arguing that the important qualification of the 'observer's sanction' might be better understood in terms of an imaginative rather than illusory engagement: an imaginative consent. I believe that the intention of such works, far from *denying* the threshold between real and unreal, is to co-opt it into the painting's semantic content. Spatial continuity is both implied *and* negated. As we have seen with *Trinity*, barriers are often raised to our implied participation: as Sandström perceptively argues, an implied '*transition* does not mean the abolition of the boundary between two spatial spheres; it demands on the contrary the appearance of some obstacle in the boundary, thus drawing attention to the latter's existence' (p. 68).

Sandström's theories of Renaissance spectatorship are subsequently taken up by

Shearman's *Only Connect ...* (1992). The arguments around 'A Shared Space' (ch. 2) are the most reception aesthetically orientated in the book, and the most relevant to the current argument.¹¹ Adapting the grammatical term *transitive*, Shearman proposes the notion of a transitive work as a painting (or sculpture) that is 'completed only by the presence of the spectator in the narrative' (p. 33). These are works that engage a beholder as a participant or witness: 'the viewer is located in the event, and the described action is transitive, completed outside itself in another focus in a shared space' (p. 39). Shearman goes on to give a rich series of examples of the ways in which Renaissance paintings and sculpture engage an external viewer within their narrative content, not all of which necessarily imply a direct *spatial* continuity. However, it is Shearman's notion of a shared space as a 'fiction of a continuum between the painted space and the real or more specifically liminal space' (p. 59) that directly impacts upon the relationship between artwork and viewer I am here describing.¹² It is on the assumption of such a shared space that 'depends the effectiveness of the psychological charge and the engagement' of transitive works (p. 59).

Shearman, not surprisingly, uses the example of Masaccio's *Trinity*. That so much of the painting is notionally on 'our' side of the wall acknowledges an unprecedented 'illusion' where the spectator's viewpoint is 'locked into the architecture of the church and related to the spectator's address' (p. 66). From this conceptual moment 'the *Trinity's* spectator is embraced in the systematic relationship of illusion and church space' in a way that the relationship 'is accommodated to him and his natural experience of the space in which the fresco stands' (p. 66).¹³ While I again have reservations about the illusory emphasis, Shearman's position – like that of Sandström's – clearly provides art historical support for my philosophical position on the role for an external spectator.

5.

Shearman openly acknowledges that his notion of the transitive work, where the narrative action *within* the work is completed in another focus *outside* of the work, is an adaptation of Riegl's concept of inner and outer unity (Shearman 1992, p. 36 and p. 59). The reference is unsurprising, as it is with Riegl that 'the beholder's involvement' is first formalised into an 'aesthetics of reception' (Kemp 1999, p. 11).

Riegl develops his distinction between 'internal coherence' and 'external coherence' in relation to Dutch group portraiture from the sixteenth and seventeenth centuries (1999), but as categories they have significance beyond such works. Paintings described as having a 'closed internal coherence' (*die geschlossene innere Einheit*) are founded on the reciprocity of pictorial elements contained *within* the picture. As Kemp notes:

Riegl's criterion of 'internal coherence' thus demands absolute reciprocity, the involvement of all the characters in a single action, and a unified formal treatment of the connecting psychological

and physical functions of the figures. The result is an uncompromising composition that builds no bridges to the viewer: the painting appears complete in itself. (1999, p. 13)

By contrast, works having an 'external coherence' (*die äußere Einheit*) are completed only by the presence of a spectator, and establish a rapport with the viewer. As Kemp summarises Riegl's argument, this constitutes 'a form of painting that later manifests its dependence on the viewer even more clearly by having the figures relate directly to him or her by means of eye contact, gesture, and movement' (Kemp 1999, p. 13).

Importantly, Riegl believes that certain painters combine both: he argues that Rembrandt 'must have realized early on in his career that complete and well-defined external coherence – meaning the connection between the viewer and the figures depicted in the painting – depends on an already resolved internal coherence – meaning a subordinate relationship among the figures portrayed' (1999, p. 253). This, according to Riegl, is what Rembrandt learnt from the Italians. The two engagements are therefore not mutually exclusive.

Riegl argues that Italian Renaissance art achieves a consistent internal coherence by the beginning of the sixteenth century, 'even though the solution was keenly anticipated a full hundred years earlier' (p. 77). This introduces an unprecedented psychological dimension to the relationship between the figures, involved in a single narrative action. Thus Riegl observes:

The figures in a Renaissance painting ... show that they are acutely aware of interacting with each other. That is to say, there is assumed to be a viewing subject present who expects the objective figures in the painting to coalesce into a unified whole. Consequently, everything is eliminated that might disturb the impression of unity. This is why Italian Renaissance figures convey much more strongly than their antique counterparts a sense of the psychological functions that connect the figures depicted, that is, emotion and especially attentiveness. (p. 77)

Riegl contrasts such a sense of attentiveness to the alternative conception of external coherence typical of early Hollandish painting, where subordination of figures to the dominant narrative action is avoided, and 'coordination' becomes the organising principle in a way where figures isolation from one another is made apparent (p. 78).

Is Riegl's historical argument borne out by the relevant Renaissance works? The question is worth pursuing at some length, and will serve to frame the examples I now employ. Certainly there is a noticeable shift throughout quattrocento Italian art towards a greater reciprocity of gestures and looks. We need only compare three altarpieces considered by Shearman's *Only Connect* (1992) to register this development. In *Trinity*, painted in 1427, the figures are self-absorbed and relatively isolated, with only Mary's gesture towards Christ directly acknowledging our presence. By around 1480, Giovanni Bellini's *San Giobbe Altarpiece* (fig. 13) marks a significant extension of the 'conversational'



Fig. 13 Giovanni Bellini: *Madonna Enthroned and Saints (San Giobbe Altarpiece)* (c. 1480), Galleria dell' Accademia, Venice.

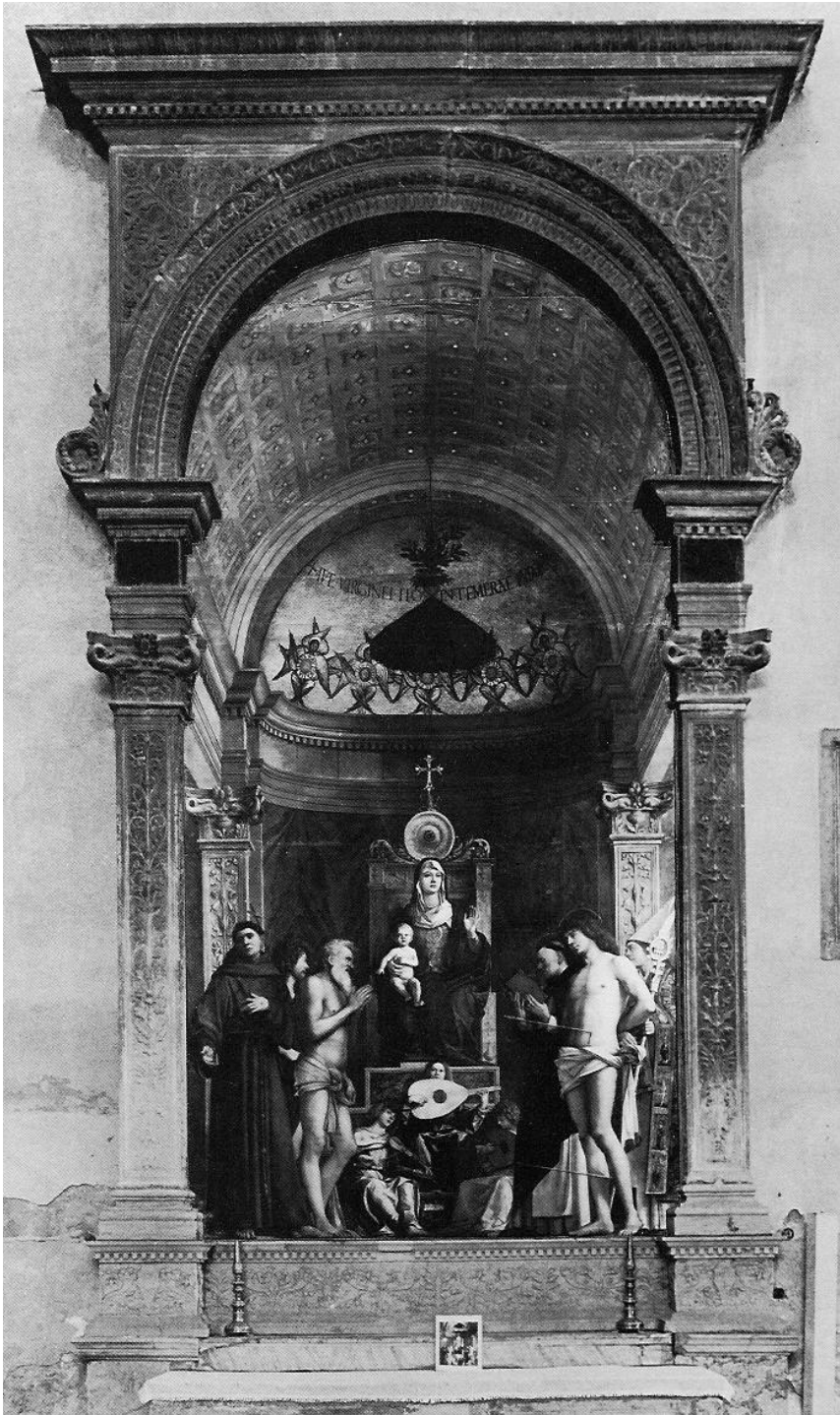

Fig. 14 Photomontage reconstruction of Giovanni Bellini's *San Giobbe Altarpiece*, in its stone frame within San Giobbe (reproduced from Shearman 1992, p. 96).

demands of the *Sacra conversazione*. As Shearman notes:

Remembering always that our name for the type has no reality in the period, we may nonetheless focus on the artistic invention that led eventually to a name being sought for it. And the fundamental shift that concerns us came earlier (between Taddeo di Bartolo, Masaccio, and Filippo Lippi), when by slow degrees the relationship between Madonna and saints was recast into a unity defined at once as spatial, sentient, and social, in a word, a community, worldlike but not worldly. (1992, pp. 98-99)

Bellini's altarpiece, like *Trinity*, is a painting where the beholder is invited to imagine that she was looking as if into a real chapel. It exhibits all the attributes I noted earlier of a work fully integrated into its architectural context: a low viewpoint relative to the life-size figures, with a centric point, at approximately eye height, around which the painting coheres, thus suggesting an implied continuity between the pictorial and viewer's space. The *San Giobbe Altarpiece* has transformed Masaccio's painted architectural frame into a real stone one. Although the altarpiece has been unfortunately removed from its still extant surround in the church of San Giobbe, a photomontage gives some idea of the impact the painting would have had within its original context (fig. 14):

Then it can be seen that this chapel, this functioning unit, erected partly as painted fiction, partly as real stone frame (its entrance arch), and partly as stone altar, against the right wall of San Giobbe, is a surrogate for the architectural chapels concurrently being built out from the left wall. (Shearman 1992, p. 95)

This integration of the real frame and painted fiction creates an even more persuasive suggestion of continuity than that offered by Masaccio, further blurring the distinctions between architecture, sculpture and painting. Unlike *Trinity*, which is located within the Gothic Santa Maria Novella (and is thus stylistically distinguished from its host building), Bellini's painted chapel is fully integrated into the architectural schema for the church, one of the earliest examples of Renaissance architecture in Venice.

Shearman highlights another subtle distinction from Masaccio's *Trinity*:

As you stand before the altar of the *Trinity*, the ground level of the space described above is slightly above eye level, so that you cannot see the floor, and the nearest edge begins to cut what you can see of the feet of the figures within, notionally standing back from that edge. The base line of the *San Giobbe Altarpiece* is fractionally below eye level, so that the saints' feet are seen on an extremely foreshortened tiled floor. These are representations of the same logic of sight, and in one sense they do not need to be packaged in more elaborate terms than that. But it is worth pursuing the point that the occlusion of the one and the barely visible horizon of the other, which derive from that logic, are very characteristic of Donatello's way of thinking. In the *San Giobbe Altarpiece* ... the rigorous logic of sight testifies to that conscious mode of representation predicated on the *a priori* acknowledgement of the spectator's presence. (p. 97)

This difference is significant, in that for all their similarities, the paintings establish a sense of shared space to different ends. While Shearman rightly remarks on the unprecedented 'psychological accessibility' of the figure group in Bellini *Sacra conversazione* (p. 98), he unfortunately does not expand on the psychological implications of the occlusion of the horizon in *Trinity*. The difference is worth pursuing. In the Bellini it is Saint Francis who 'while displaying Christ-like his stigmata, seems in the same gesture to invite us to approach this Throne of Grace' (Shearman 1992, p. 98); if 'Saint Francis addresses a spectator directly in front of the altar', then by contrast the Virgin 'seems to turn with welcoming gesture toward others approaching from behind us on our right, from the entrance to the nave of San Giobbe' (p. 100). This complex engaging of the spectator within the very architecture of the church emphasizes both the intellectual and psychological accessibility of the figure group in the *San Giobbe Altarpiece*. In Riegl's terms, there is a greater internal unity than in the Masaccio – a unity which is extended to include a spectator conceived as part of a community.

This inclusive unity is very different to the revelatory impact of the *Trinity*, an impact (as we shall see) that is predicated on Masaccio's deliberate ambiguity as to the location of the Trinity within the scene, and the restrictions thus placed on our participation. If, in the Bellini, Saint Francis both displays his stigmata *and* welcomes us into the community, when Mary acknowledges our presence in *Trinity* her gesture is directed to each and every beholder. The spatial continuum of the Bellini provides the spectator with an unprecedented access to a community that is 'worldlike but not worldly', whereas *Trinity* maintains a sharper divide between two coexistent realms; the address is directed very much to an *individuated* beholder (even if that beholder is part of a congregation). If Bellini's altarpiece engages a more complex set of narrative devices, its internal unity is gained, as Riegl predicts, at the relative loss of its direct address to the spectator.

Yet the unity of the *San Giobbe Altarpiece* is certainly not complete. The figures are still characterized by a sense of isolation from each other, and from the spectator. This is a somewhat attenuated *Sacra conversazione*, in that few, if any, of the gazes actually meet. Saint Francis does not look at the viewer, but to a position to our left, while each character seems to stare into space: including the Christ child who stares at a position located some distance above the beholder's head. The protagonists are each absorbed by their inner thoughts: the painting, while psychologically accessible, is also turned inward.

By the 1520s, however, in a work such as Titian's *Pesaro Altarpiece* (fig. 15), the unity of narrative action and reciprocity of gestures and looks is fully complete. As Shearman notes of the Frari painting, 'the activation of the figure group is extended much further than in Bellini's – so far, indeed, as to include symbolic and historical narrative' (1992, p. 99). But the extraordinary innovations of Titian's work push the altarpiece type we have been discussing to the very limit.



Fig. 15 Titian: *Pesaro Altarpiece* (1519-26), S. Maria Gloriosa dei Frari, Venice.

Unlike *Trinity*, the donors of the Pesaro family no longer occupy 'our' space, but are (not *altogether* successfully) incorporated into the virtual space of the fictive world behind the picture surface.¹⁴ Bishop Jacopo Pesaro, who kneels 'at the steps of the Virgin's throne', is accompanied by figures integral to the narrative action: 'a warrior holding the flag of the papal fleet and by two captives, one a Turk, the other a Moor' (Shearman 1992, p. 100). The strong diagonal emphasis sets up an internal dynamic crucial to the narrative content:

The bishop commemorates his victory over the Turks, as admiral of the papal forces, as Santa Maura in Cyprus in 1502, and because it was a papal and not a Venetian victory he kneels first and rather pointedly at Saint Peter's feet. (p. 100)

Unlike Bellini's altarpiece, which is fully integrated into the architecture of San Giobbe, here the fictional architecture is no longer an obvious extension of its host. Rona Goffen claims that 'rather than establishing an illusionistic continuity between the actual and fictional spaces of church and picture, Titian insisted on a disjunction between the two realms' (1986, p. 112). Nevertheless, there is still an acknowledgment from *where* the spectator has arrived. Approaching the work obliquely from the nave, as the viewer passes from the third to the fourth bay on the left:

He then sees, as it were complacently, empirically, and guided by memory, what the historian of altarpieces sees with so much surprise, which is that Titian has turned the group of Madonna and saints, together with the podium and the steps of her throne, toward the main entrance of the church. (Shearman 1992, p. 99)

Not only has Titian rotated the scene towards the entrance: as Puttfarken observes, Titian aligns the altarpiece with his own *Assumption* over the high altar, a work framed by the earlier choir-screen, and in so doing reinvents the *Sacra conversazione* by rotating it ninety degrees. While it might initially appear that the *Pesaro Altarpiece* radically abandons 'the format of centralized bilateral symmetry' (p. 137), in fact, as Peter Humfrey notes, 'In a sense, what Titian is showing us is a Bellinesque figure group viewed from an oblique angle rather than frontally' (1993, p. 188; cited in Puttfarken 2000, p. 144).¹⁵

What are the consequences of this radical rotation? Shearman argues against the notion that 'the picture looks best, or was ever meant primarily to be seen, from forty or sixty degrees to the left of the normal axis, but was meant to be seen from dead in front' (1992, p. 99). This somewhat misrepresents the Puttfarken argument to which it refers; while Puttfarken argues that the physically oblique approach suggested by the acentric perspective 'helps to confirm and heighten the presence of the large and appropriately foreshortened sacred figures' (2000, p. 145), he *also* recognizes that the work presents a frontal view. Indeed, I would argue that the work implies two 'ideal' viewing positions,

one consistent with the acentric vanishing point, and one with the centralizing frame (which has somewhat lost touch with the fictional space). Of course, in reality the spectator will adopt many shifting positions toward the painting: it should be stressed that these are positions *implicit* within the work.

Puttfarken notes that in earlier versions of the painting,¹⁶ the section of wall on the right supported a barrel vault, a scheme that would have heightened the acentric perspective construction (2000, pp. 145-147). He notes how subsequent versions lessen the impact, with the two vast columns acting as 'a solution to Titian's problem of reconciling the frontal view of the donors with the oblique view of the sacred figures and their perspective – columns, in particular without foreshortened capitals, fit easily into both views' (p. 147). While this is undoubtedly true, I believe the oblique view also offers something that Puttfarken does not comment upon, though it would appear to support his argument: from this position (and from no other), not only are the fictional columns 'a coherent part of the perspective construction' (p. 147), but they are seen as being consistent with, even a continuation of, the great columns of the Frari's nave.¹⁷

This directional emphasis, which references the memory of our arrival, is balanced by another complex movement, again completed *outside* of the fictive space. The Christ Child turns to Saint Francis, whose gesture commends the Pesaro family to the Madonna. As Shearman notes, the Child 'lifts the Virgin's veil, apparently a playful gesture but at the same time an intimation of the symbolic role of the mantle of the Madonna of Mercy, as if to take them under her protection, too' (1992, p. 101). This complex movement is completed by the youngest family member, Niccolò Pesaro, who turns to acknowledge our presence, a presence directly in front of the work. This is a 'welcome offered by a child to the mortal congregation' (Goffen 1986, p. 114).

While we are therefore certainly not excluded as a presence, I would argue that ours is a more peripheral (if still important) role than that implied by the direct revelatory address of *Trinity*. Our imaginative engagement is that of an acknowledged onlooker rather than a direct participant. The example of Titian's altarpiece might stand-in for many others that follow, where, as Riegl suggests, a more complex internal unity has supplemented, if not replaced, an earlier external coherence. In the Titian, the donors play active roles as intermediaries integrated into the work's narrative. Whereas the patrons in *Trinity* are confined to our empirical space, excluded from the space of the Trinity beyond, in the *Pesaro Altarpiece* Bishop Jacopo Pesaro is being presented to the Virgin (as in votive images), and is thus incorporated into the inner narrative. This is no longer *our* revelation. While we are not excluded as such, the work is dictated to a far greater extent by the internal logic of its narrative.

While the *Pesaro Altarpiece* conforms to many aspects of the first of my two modes of situated relationships, the work's (relative) independence from its host architecture, and

the more peripheral involvement of the external spectator, places it at the mode's limits. The loss of spatial continuity, implied by the acentric perspective, suggests a blurring of the engagement afforded an internal or external spectator. While it still can be said to activate our physical space in terms of registering our direction of arrival, in Riegl's terms the work's external coherence is dependent upon (or at least mediated by) a highly resolved internal coherence. What this fails to register, however, is the accompanying shift from an implied external spectator, directly addressed as a physical presence or witness standing within the actual space of the church, towards an identification with an internal spectator, internal to the virtual space of the painting, and absorbed into the complexity of the work's narrative content. In a sense, the role of the Bishop is a precursor of the internal spectator (or, rather, an attenuated version of the internal spectator); while he is represented *within* the painted scene, we imaginatively identify with his position as an equivalent to the kneeling position we might have formerly have adopted as an external spectator in front of a Bellini *Sacra conversazione*. And yet we are simultaneously engaged by the young Niccolò Pesaro.

The Titian stands at the cusp of two different modes of engagement. The compromise is registered in the not altogether convincing integration of the donors into the work's fictive space. Bishop Jacopo Pesaro, while integrated into the work's narrative through an exchange of glances, is still painted frontally, in profile, a static counterpart to the twisting three-dimensionality of the main protagonists. The front figure of the family group on the right, Antonio Pesaro, likewise feels isolated, his integration into the fictive space incomplete. The two primary donors thus hover between being integrated into the narrative, and anachronistic relics of an earlier (but by no means inferior) Florentine tradition where the patrons belong to 'our' world, the real space of the church. If I am right to contend that Riegl fails to adequately distinguish between the different kind of engagements afforded by internal and external spectators, to which I will return, then I would offer the *Pesaro Altarpiece* as evidence of Titian's extraordinary inventive but ultimately compromised attempt to reconcile the two.

6.

The final altarpiece I consider again creates a tension between an implied spatial continuity and a rather extraordinary spatial separation. Giovanni Bellini's *San Crisostomo Altarpiece* (*St Jerome with SS Christopher and Louis of Toulouse*) (fig. 16) is the painting with which Wollheim chose to conclude *Painting as an Art* (1987). The painted architecture implies a strongly felt continuity between the space of the front two saints and that of the church; in a tacit acknowledgement of this fact, Wollheim refers to an 'architecturalization of a large zone of the painting', whereby the flanking saints are in a reciprocal role with the architecture (p. 354). By contrast, the location of St Jerome - depicted within the wilderness - lacks spatiotemporal markers relative to the viewer. Wollheim notes how this 'assimilation



Fig. 16 Giovanni Bellini: *St Jerome with SS Christopher and Louis of Toulouse* (1513), San Giovanni Crisostomo, Venice.

of the two flanking saints to architectural members of a structural sort' then 'colludes with a powerful Belliniesque, here carried to new lengths: the compression of space' (p. 354). In a wonderful observation, borne out by my own experience in front of the painting, Wollheim notes how that part of the painting behind the enclosing wall, the section containing St Jerome, 'eases itself forward' (p. 354).

But Wollheim rather surprisingly fails to mention Bellini's innovative use of late afternoon light to suggest a spatial continuity (perhaps because it threatens Wollheim's notion of painting presenting a self-contained world). At this time of day, the light entering the chapel, from the window immediately to the right of the painting, is consistent with the painted light, and really does seem to cast the painted shadows that reinforce the figural presence of the two flanking saints. This is particularly noticeable with the vertical shadow cast by St Christopher's staff, a feature that supports Wollheim's notion of the work's architecturalization. And yet, simultaneously, the warm light unites the three saints, 'in spite of their isolation', in 'a shared contemplative mood' (Goffen 1989, p. 186). It is an astonishing reconciliation of two very distinct relationships, one reinforcing a spatiotemporal continuity that insists upon the 'here and now', one insisting upon a disjunction between realms.

7.

Earlier in this chapter, I noted a similarity between Bryson's first (Albertian) epoch of perspective, and the kind of relationship between artwork and beholder implied by an external spectator. The relationship I now describe has something in common with Bryson's notion of the second (culminatory) epoch of perspective (1983, ch. 5). According to Bryson, these works are *inadvertent*: 'the spectator is an unexpected presence' and 'nothing in the scene arranges itself around [the viewer's] act of inspection' (p. 111). Unlike the first relationship, the viewer is excluded as a direct 'physical' presence. As Bryson argues of Vermeer's *The Artist in his Studio* (fig. 6):

The perception is presented to the viewer to examine from his own position – he is not being invited to move up to a viewfinder, or step inside the perception; there is an asymmetry between the original perception, recorded in the image, and the act of viewing. *Trompe l'oeil* is in fact renounced: the bond with the viewer's physique is broken, and the viewing subject is now proposed and assumed as a notional point, a non-empirical Gaze. (p. 112)

Now despite apparent similarities to my position, I would contest a number of aspects of Bryson's argument. While the scene Vermeer presents may not cohere around the beholder in the manner of Masaccio, I would argue that Bryson fails to register that this second mode of viewing represents not so much a subjective advance as a fundamentally new notion of the nature of the viewer: a beholder who is now conceived as *internal* to



Fig. 17 Rembrandt: *The Syndics* (1662), Rijksmuseum, Amsterdam.

the virtual world.¹⁸ Bryson's proposition that 'the spectator is an unexpected presence' should be reconfigured to read the *external* spectator is an unexpected presence. While with the Vermeer the bond with the viewer's physique is undoubtedly broken, the work nevertheless does not preclude a presence internal to its world. This is despite the self-sufficiency of the scene, and the depicted artist's evident absorption in his activity. As Edward Snow writes:

[I]nstead of rejecting us by coolly insisting on our visibility, the painting now peels back its tapestry as if for our benefit, and even provides a chair for our invisible presence within this self-surrounded scene - in a place that is reserved for us *as* viewer, not someone still driven by a nostalgia for vicarious participation. (1994, p. 141)

Now we perhaps need to define Snow's notion of 'a place that is reserved for us *as* viewer'; the potential view from the chair is clearly different from that afforded by an identification with a viewer occupying the work's depiction point. Nevertheless, if the work does not directly imply a *spectator in the picture* in Wollheim's strict terms, I believe that Snow is right to suggest that what it does do is invite, as it were, the external beholder to identify with an unrepresented internal spectator who might, contrary to Bryson, potentially *step inside the perception*. Not that part depicted as being *in front of* the picture surface, but into the virtual world itself.

Having said this, by no means all seventeenth-century Dutch works exclude the external beholder. Rembrandt's *The Syndics* (fig. 17) or *The Anatomy Lesson of Dr. Tulp* (fig.



Fig. 18 Rembrandt: *The Anatomy Lesson of Dr Tulp* (1632), Mauritshuis, The Hague.

18), for instance, might legitimately be seen as engaging an external spectator. Puttfarcken has emphasized how the sense of presence in *The Syndics* is established through life-size scale and the 'psychologically charged and undeniably communicative glance out of the picture by all the figures' (2000, p. 17). Despite the fact that these works are not strictly integrated into their architectural contexts in the manner of Italian altarpieces, they are commissioned for specific locations and for anticipated viewers. Indeed, Riegl's *The Dutch Group Portrait* (1999) catalogues a number of works that have an external coherence completed by the presence of what might be referred to as an external beholder, but one who is increasingly invited to engage with the internal scene. As noted earlier, Riegl argues that Rembrandt finds his external coherence on a fully resolved inner unity, dependent upon subordination (p. 253). Riegl regards the animated physical gestures of the earlier *The Anatomy Lesson of Dr Tulp* as introducing too strong a sense of 'the psychological expressions of will and emotion' for the demands of a group portrait (p. 258). But with *The Syndics*, the solution to the problem of group portraiture has, for Riegl, been found, in that 'the figures charged with establishing internal coherence are the same ones responsible for external coherence, which is now perfectly specific in time and space' (p. 285). It depicts a single moment of time that is instigated by the viewer's physical arrival at the scene.

Christiane Hertel notes of *The Syndics*: 'the gentleman on the left is already in the process of getting up to greet me, speak to me, or accept the message or refreshments I



Fig. 19 Frans Hals: *The Regents of Saint Elizabeth's Hospital* (1641), City Museum, Haarlem.

bring on a tray. Any one of these possibilities is already part of the painting's story, in that Rembrandt has included the man's reaction to the interruption' (1996, p. 54). Now, given the apparent complexity of the emotions of the figures that address us, it is highly unlikely that the interruption is one of refreshments. Indeed, the work has encouraged endless anecdotal speculation as to the nature of the exchange.¹⁹ And yet it is certainly the case that compared to our somewhat peripheral role as bystander in the *Anatomy Lesson*, in *The Syndics* we play a far more active role in initiating such a response.

With both works, Rembrandt extends what Riegl would describe as a commonality to include the viewer as an implied yet external presence. Contrary to Wollheim's argument in *Painting as an Art* (1987, pp. 176-183), where he claims the implied viewer of such works as a spectator *in* the picture, the reactive responses of the 'unrepresented spectator in their midst' (p. 181) is anticipated by these paintings' institutional contexts. The spectator's psychological repertoire is determined, at least in part, by the specificity of their original contexts. With *The Syndics*, this was the *Staalhof*, where the *Staalmeesters* of the Clothmaker's Guild met. That Riegl fails to distinguish between internal and external beholders perhaps follows on from his exclusive focus on such commissioned group portraits, painted for specific sites and audiences, where roles of internal and external spectators inevitably merge. Yet he does register a distinctive shift in the relationship between work and viewer, which he argues represents a shift from subordination to coordination. In a key passage with respect to Frans Hals's *The Regents of Saint Elizabeth's Hospital* (fig. 19), Riegl writes of the need to psychologically analyse each figure:

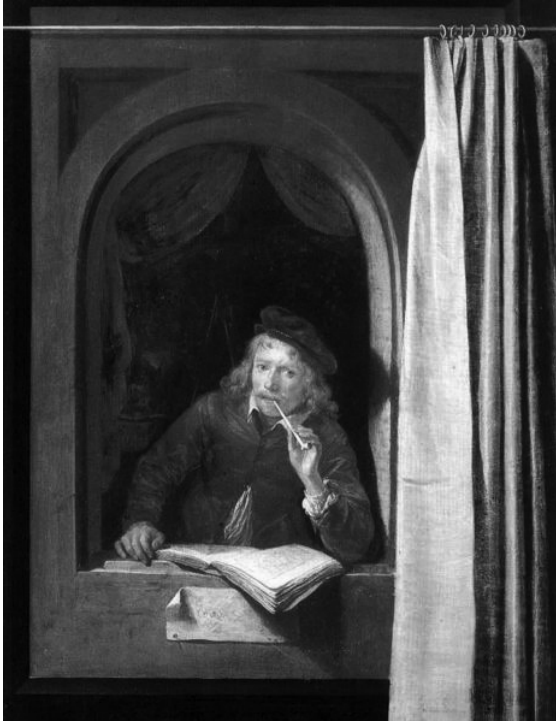

Fig. 20 Gerard Dou: *Self-Portrait with Book and Pipe* (c. 1650), Rijksmuseum, Amsterdam.

As a result of this intense process that viewing subjects are expected to undergo and that makes demands on their whole conscious experience, they become so intimately implicated in the inner workings of the scene, so deeply invested, so to speak, in the reality of what is happening there, that what began as an external incident becomes an inner experience. In short, this is the pictorial conception of the genre painting of seventeenth-century Holland ... [that has] outgrown the device of having figures directly address the viewer. The artists espousing this brand of pictorial conception no longer thought it necessary to make a special effort to draw the viewer's attention to the existence of the viewing subject outside the objective world of the painting. (1999, p. 344)

Despite the now questionable implication of artistic progress, this wonderfully insightful passage charts a decisive shift towards an internalisation of the experience of viewing.

In Vermeer's *A Girl Interrupted at her Music* (fig. 23), the institutionally anticipated interruption of *The Syndics* is transformed into an interruption which is now undoubtedly entirely internal to the scene. As Hertel notes: 'The reception of genre paintings bears witness that in them painting and its contemplation have lost their commonality, have become two private activities dissociated from a common history and a public culture' (1996, p. 54). There is a shift toward what Puttfarken terms easel painting. But before exploring the nature of this shift for the implied spectator, I raise a fundamental distinction that is rarely acknowledged. The distinction is between: (i) works such as *Trinity* and *The Syndics*, where the external viewer as an anticipated presence within an institutional context has been drawn, as it were, into the inner world of the painting (in the former retaining an awareness of the surrounding architecture); and (ii) works where the viewing subject, while directly



Fig. 21 Jean-Baptiste Siméon Chardin: *The House of Cards* (c. 1737), National Gallery of Art, Washington.

addressed, remains resolutely *outside* of the fictional world painting presents: as Riegl puts it, 'outside the objective world of the painting' (p. 344).

If we now return to Maes's London *The Eavesdropper* (fig. 1), this is a work that we might recall engages the beholder *of* the painting rather than an implied presence *in* the painting, setting up precise limits to our implied participation through the use of the painted curtain. With Maes's work, this engagement is confirmed by the presence of what Louis Marin would refer to as a 'figure of the frame' (1996, p. 83-84), an internal figure aligned with the work's boundary, who 'theatrically' draws our attention to the narrative content.²⁰ This work creates a tension between the two modes of imaginative engagement, and embraces a *trompe l'oeil* element as an integral aspect of the imaginative experience. A similar example is presented by Gerard Dou's *Self-Portrait with Book and Pipe* (fig. 20), a work which likewise incorporates a *trompe l'oeil* curtain. Here the uncertainty between the 'illusory' status of the curtain and the fictive space beyond is reinforced by the presence of the artist, author of the conceit, *within* the scene. The curtain, again painted as if *in front of* the picture plane, entices the external spectator to pull it back further in order to reveal more of the 'painting within a painting'. The curtain insists upon the very flatness of the picture it part 'conceals'. To repeat an argument made earlier, this direct appeal to our participation is not, I believe, necessarily dependent upon us being 'fooled', but upon our imaginative engagement as an external spectator whose space has been engaged within limits defined and structured by the work. The scene 'behind' is experienced very differently. Smaller than life-sized,



Fig. 22 Gerard ter Borch: *Curiosity* (c. 1660), The Metropolitan Museum of Art, New York.

it presents the fiction of the artist leaning into 'our' space from an arched niche. But while the strong shadows cast by the painter and his precariously balanced book imply an encroachment into the space of the viewer, this typical *trompe l'oeil* device (unlike the drape) no longer encroaches upon the 'real' space of the external beholder (it lies 'behind' the curtain), but is presented as an extension of the virtual space of the inner painting. The work sets up a perceptual and imaginative conflict as the viewer shifts between two modes of implied spectatorship that are ultimately irreconcilable.²¹

Fried would, with some justification, designate such a relation to the beholder as *theatrical*. But in granting Fried this designation, I want to again stress that it is a relation that is quite distinct from works such as Masaccio's *Trinity* or Bellini's *San Giobbe Altarpiece*, despite the similar role allocated to Mary or St Francis as 'figures of the frame', implicating us within the scene presented. These paintings ally their structure to content in a way whereby the internal and external spectators fuse, without ever losing sight of the significance of the picture's surface as threshold. By contrast, with Maes's and Dou's works not only do these roles refuse to merge, but – quite to the contrary – they are meant to be experienced as mutually exclusive: in denying painting's depth, they draw attention

to the fictional nature of the scene, and to our effective exclusion. It would seem that we are required to distinguish not only between internal and external spectators, but between divergent roles for the external beholder.

We are now in a position to begin to clarify an important aspect of the argument. If, as Margaret Iversen notes, 'the most innovative aspect of the *Dutch Group Portrait* is undoubtedly the explicit theoretical formulation of a kind of composition that presents only part of what constitutes its totality and, so to speak, reaches out to the spectator to complete the scene' (1993, p. 127), then we need to (i) acknowledge that this role can be performed by either internal *or* external beholders, and (ii) distinguish between those external beholders who, while drawing the experience of the surrounding architecture into the imaginative engagement, are nevertheless merged with the implied internal spectator, and external beholders engaged precisely as *external* presences.

The latter distinction has particular relevance to Fried's position. In *Absorption and Theatricality: Painting and Beholder in the Age of Diderot*, Fried records how in mid-eighteenth century France the presence of a beholder is first theorised as being problematic (1988, p. 93). Thus Fried writes of genre works such as those by Chardin (fig. 21):

[T]he persuasive representation of absorption entailed evoking the perfect obliviousness of a figure or group of figures to everything but the objects of their absorption. These objects did not include the beholder standing before the painting. Hence the figure or figures had to seem oblivious to the beholder's presence if the illusion of absorption was to be sustained. (p. 66)

Fried has been rightly criticised by Wollheim for failing to distinguish here between the external and the internal spectator (1987, pp. 364-365). As we have noted, the depiction point is internal to the virtual world of the painting – it does not correspond with the beholder standing before the painting, unless it has been integrated into the host architecture. But we need to now further distinguish between divergent roles for the external beholder. Some external spectators are drawn into the virtual world painting presents as participants, while retaining both an awareness of the metaphysical distinction implied by a picture's surface, and of their positioning in real space. Others, more passively, are external to the world of painting presented *as* fiction.

Let us compare two genre works where a figure within the scene directly addresses a spectator. Gerard ter Borch's *Curiosity* (as Peter C. Sutton notes, a later eighteenth century 'anecdotalizing title' (1984, p. 149)) presents three figures plus an equally 'curious' spaniel (fig. 22). The woman on the right 'leans over the letter writer's shoulder', so much so that 'her irrepressible interest in the letter writer's response to the unsealed missive prompts her to lean precariously over the chairback' (Sutton 1984, p. 149). I would contend that the elegantly attired woman on the left, looking outward, engages not an unrepresented figure internal to the work, but the curiosity of a beholder external to the scene. As an onlooker (a

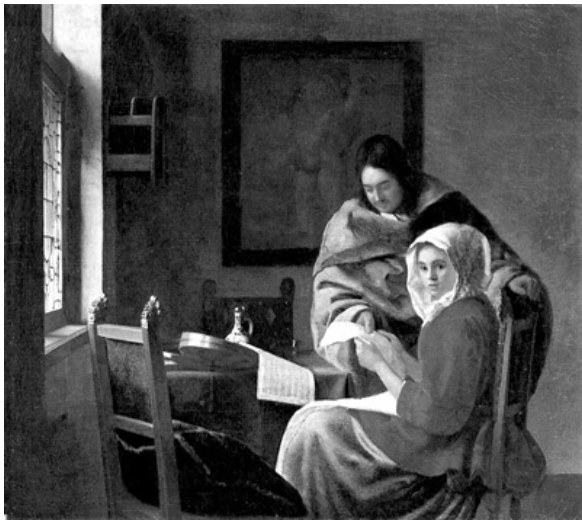

Fig. 23 Johannes Vermeer: *A Girl Interrupted at her Music* (c. 1660-61), The Frick Collection, New York.



Fig. 24 Johannes Vermeer: *The Love Letter* (c. 1669-70), Rijksmuseum, Amsterdam.

direct counterpart of the figure straining forward within the fiction), we are 'invited' by the mediating figure on the left to speculate as to the content of the letter, thus completing the work's narrative, not as an intrinsic participant but as an addressed (external) audience. While this work omits Maes's painted curtain, the mediating figure continues to play much the same role as the maid in the London *Eavesdropper*. We are simultaneously engaged but excluded, the work, 'staged' for our benefit, drawing attention to its fictional and essentially anecdotal nature.

By contrast, and despite the striking similarity of subject matter, Vermeer's *A Lady Writing a Letter* (fig. 10) transforms ter Borch's anecdotal curiosity into a psychologically intense reciprocity between the woman interrupted and an unrepresented presence: a presence who is *internal* to the virtual world of the painting. With great skill, this presence is acknowledged as someone who is familiar, perhaps even intimate with the woman. Here, the gender of the implied (as opposed to external) beholder arguably becomes an issue. The subtlety of this reciprocal contact, and the heightening of its psychological effect, is gained by identifying with the unrepresented presence within the work, a reciprocity over and above what is gained by perception unaided. Regardless of stylistic differences between the works, there is a gulf between the remoteness of ter Borch's staged scene and the restrained intimacy of the Vermeer.²² If the former relation might legitimately be described as theatrical, this is decidedly not the case with the latter, despite its direct engagement of a beholder.²³

8.

The genre works now being discussed are typically smaller, more intimate works on panel or canvas, where the continuum between the pictorial space and the spectator's space is broken, and the viewer stands in a space *other* than the space of representation. As Puttfarcken has shown in 'Scale and Presence' (2000, ch. 5), this issue of scale is not without significance. Such works are no longer integrated into their architectural surroundings; rather, the virtual world inside the frame has been separated out from the real world of the beholder. The framing - presenting a world isolated from that of the beholder - is less self-contained, in the sense that, as in contemporary photographs, objects are often abruptly cut into at the picture's edges, and the positioning of the vanishing point is seemingly arbitrary. There is not the processional demands of Italian altarpieces. The preexisting fictional world continues beyond the bounding frame; this world is temporally removed from the conditions of the spectator (although we can access this world through an imaginative identification). As Alpers notes, this is 'a prior world seen' (1989, pp. 41-42)

In an important insight, Wolfgang Kemp contends that 'the behavior of the beholder is also decisively stimulated by the way in which the artistic scene or action is depicted, in its cropping, its details, its fragments' (1998, p. 188). This is true of many genre works, but is particularly so of paintings implying an internal spectator as part of their content. Kemp argues that the notion of painting conceived as a fragment has only intensified since the seventeenth century, when painters became interested in the possibilities of such a 'radical cutting into a presumed preexistent reality' (p. 188). But this also has consequences *beyond* internal spectatorship. Kemp goes on to argue:

Though completing the incompleting might be one way of beholding a painting, it remains the case that every artistic activity entails drawing a border and defining itself by what it has excluded. If the selection of the painted 'fragment' is recognized as an intersubjective strategy, then so too must be the classification of the realm of the visible according to categories such as exposition versus obstruction, accessibility versus inaccessibility. This process depends on whether objects are demonstrably revealed to or hidden from their beholder, whether they let themselves be observed or deliberately elude visibility, just like everything that exists outside the boundaries of the painting. (p. 188)

This suggests that we perhaps should not draw too definitive a line between the significance of works engaging an internal spectator, and those that are completed by other, related means. Vermeer is particularly pertinent to this argument, in that he creates a subtle range of works where internal beholders are directly or indirectly acknowledged, ignored, denied as a presence, or simply unregistered. This is not an all or nothing affair.

We have already noted how such a presence is directly acknowledged in *A Lady Writing a Letter* (fig. 10), and the potential to enter the representational space implied but unacknowledged in *The Artist in his Studio* (fig. 6). Our intrusion is registered with some

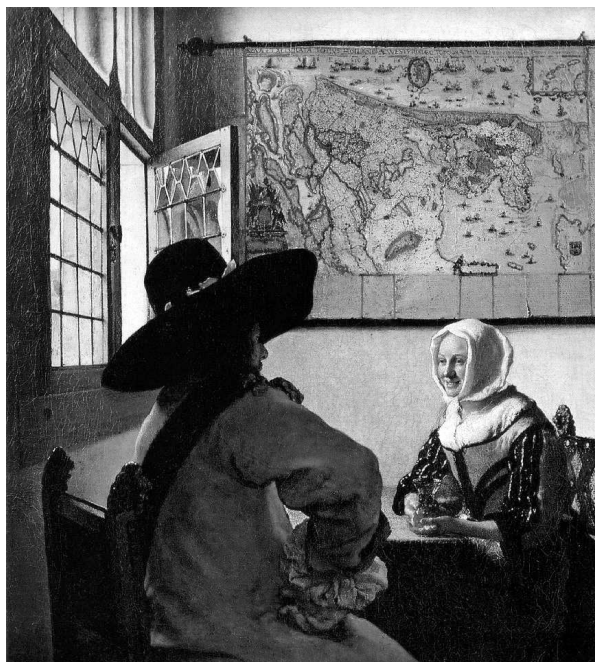

Fig. 25 Johannes Vermeer: *Soldier and Laughing Girl* (c. 1658), The Frick Collection, New York.

Fig. 26 Johannes Vermeer: *Guitar Player* (c. 1672), Kenwood House, Lord Iveagh Bequest, London.





Fig. 27 Johannes Vermeer: *A Woman in Blue Reading a Letter* (c. 1662-64), Rijksmuseum, Amsterdam.

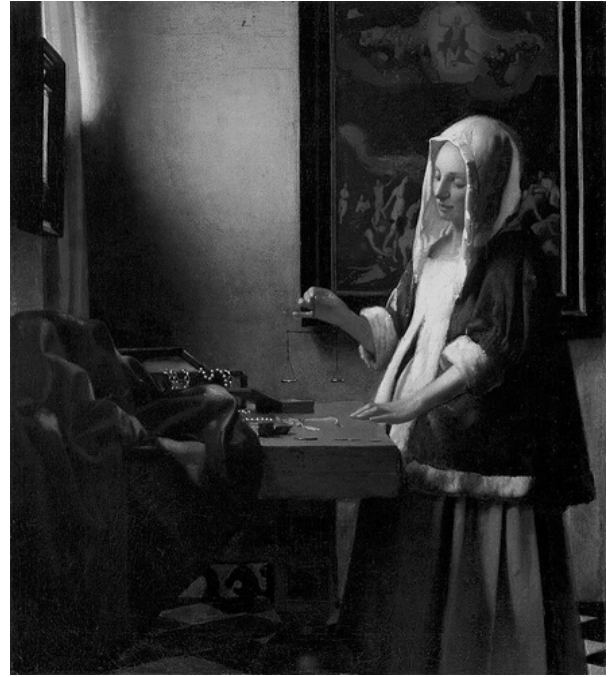

Fig. 28 Johannes Vermeer: *A Woman Holding a Balance* (c. 1662-64), National Gallery of Art, Washington.

embarrassment in *A Girl Interrupted at her Music* (fig. 23), while it goes completely unnoticed in *The Love Letter* (fig. 24). In a work such as *Soldier and Laughing Girl* (fig. 25), our presence is effectively excluded by the posture taken up by the man in the foreground (in contrast to the woman's apparent openness). In the *Kenwood Guitar Player* (fig. 26) our presence is ignored despite our very proximity, the women rapturously caught up in an exchange with a figure located off scene and to our left.²⁴ Frustration, perhaps even jealousy, ensues.

Fried documents one absorptive strategy that both Vermeer and Chardin employ to suggest the obliviousness of the depicted figure to anything other than the object of their internal absorption:

But Chardin's genre paintings, like Vermeer before him, go much further than that. By a technical feat which virtually defies analysis – though one writer has remarked helpfully on Chardin's characteristic choice of 'a natural pause in the action which, we feel, will recommence a moment later' [Châtelet 1964, p. 204] – they come close to translating literal duration, the actual passage of time as one stands before the canvas, into a purely pictorial effect: as if the very stability and unchangingness of the painted image are perceived by the beholder not as material properties that could not be otherwise but as manifestations of an absorptive state – the image's absorption in itself, so to speak – that only happens to subsist. (1988, pp. 49-50)

We might think of quite a number of Vermeer paintings that capture such a pause in time, such as *A Woman in Blue Reading a Letter* (fig. 27), or *A Woman Holding a Balance* (fig. 28). Perhaps this reflects Vermeer's own detachment (a detachment that persists despite, or even because of, an unprecedented intimacy). As Gowing writes:

Eyes never meet in Vermeer, action is stilled. There is no speech, these almost unmoving figures communicate by letter or on the keyboards of virginals. It is as if they were meditating on the barriers which lie between them. We may fancy that their relations reflect another, between them and their painter. (1997, p. 26)²⁵

Nevertheless, contrary to the thrust of Fried's brilliant but one-sided Diderotian position on the exclusion of the beholder, Vermeer alternates between highly differentiated strategies that either engage or negate the viewer as a presence. This differentiation is consistent with the demands of each painting. What is interesting to note here, and is acknowledged by both Fried and Wollheim, is that the claims 'to the effect that the spectator of the picture *could have been* part of the content of the picture' arise in relation to the efforts of the artist to 'exclude him' as a presence (Wollheim 1987, p. 364). It seems that far from defining mutually exclusive strategies, *the one implies the possibility of the other*.

With this in mind, let us return to a work referred to earlier, Vermeer's *The Music Lesson* (fig. 3). Gowing's observation about Vermeer's detachment was never truer than with this work, manifest in the psychologically charged distance that separates the man and woman. The even greater distance between the couple and the work's depiction point is accentuated by Vermeer's familiar barriers, such as the table, chair and discarded viola da gamba. Snow refers to the works 'cavernous space', and of 'a charged interval not directly bridged' (1994, p. 104). And yet he argues that the work realises 'the sense of intimate access to the human content of the scene, not only in spite of but as a function of the remote perspective that suspends life in images' (p. 112).

The complexity of these relations is focused by the role Vermeer assigns the mirror (fig. 4), a device that draws us into the scene's reciprocity, despite our very real sense of exclusion, manifest as a felt absence. Thus Snow writes:

But to leave the central relationship here would be to ignore the part played by the mirror, which mediates along with the virginal, and causes the image to portray something different from the pathos of abject or unrequited love. The man may be depicted as isolated in his desire, gazing with feelings he keeps secret at a woman he assumes to be his object, and who in turn conspires to seem so, equally isolated herself by keeping her awareness of his gazing to herself ... But the mirror constructs a different relationship. Reflected in it, the woman becomes a *viewer*, gazing unseen across one threshold toward a man who gazes similarly across another threshold toward her real presence. (p. 114)

In the mirror, the reflection of the woman is subtly manipulated by Vermeer to emphasize an implied twist already apparent in her head and neck: the mirrored woman turns noticeably towards the man. In a key observation, Snow goes on to suggest that the mirror 'reads more convincingly as a projection of her inner, otherwise unexpressed aspect - of what she might be thinking, of how she would *like* to gaze - than as a straightforward

reflection of her look' (p. 115). And it is the extreme angling of the mirror away from the wall, made apparent by Philip Steadman's reconstructions of the painting (2001, ch. 5), which allows Vermeer to reveal the woman's look.²⁶ And yet it is also the angled mirror that doubles up to reveal signs of Vermeer's activities as a painter – it acknowledges our viewpoint while negating any suggestion of an actual presence (Vermeer's, or that of an internal viewer). Our 'palpable' absence is compensated by a privileged access to the woman's inner world, what Puttfarken would refer to as a *rewarded position*. Our physical presence is replaced by an unprecedented psychological reciprocity, independent of our actual presence. This imaginative identification with the woman, provided by the mirror, is a surrogate for the kind of imaginative identification we are offered by other Vermeers as an internal spectator, a spectator *in* the painting.

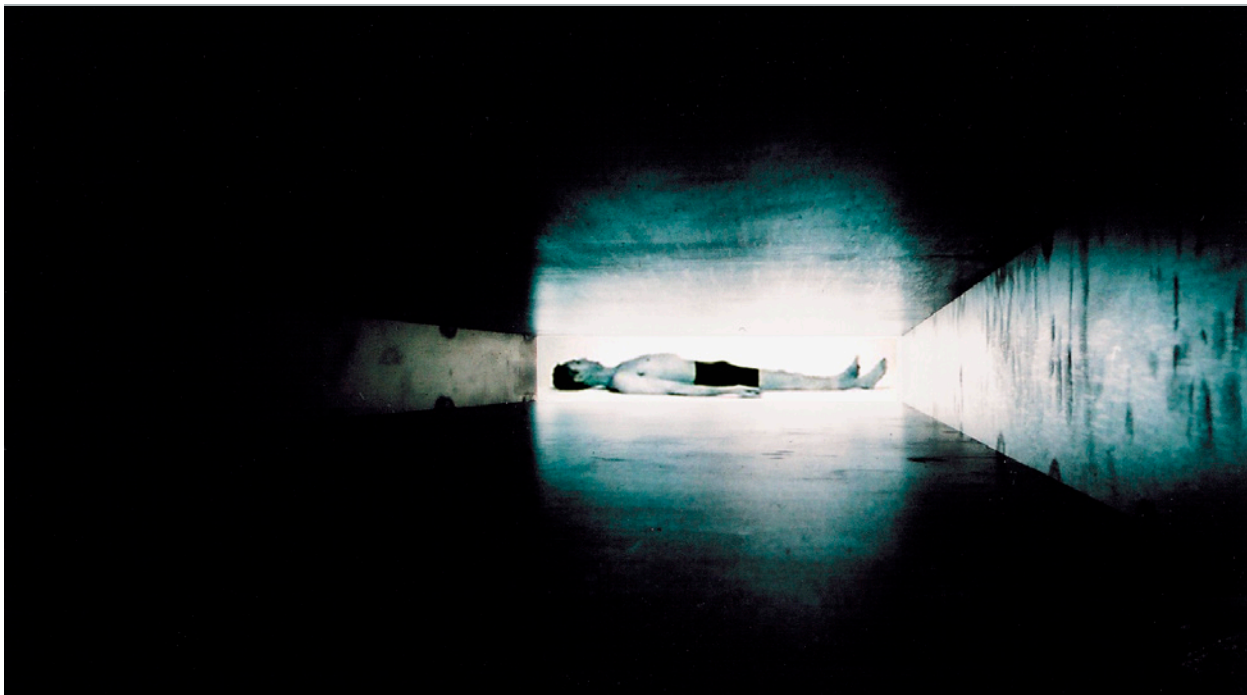

2003

CONDUIT

Conduit is a site-specific work that was installed at the M² Gallery in Peckham, London. The gallery comprises of a square recessed opening set into the front of a building designed by Quay 2c architects. *Conduit* places a flat metal plate, 900mm², immediately behind the glass of the window opening, into which a thin, horizontal slot is deeply recessed. The slanting sides create a false perspective with an asymmetrically placed 'vanishing point'. The work constitutes the equivalent of an 'Albertian window', the steel plate corresponding to an intersection. At the rear of this slotted space is a looped video image of a diminutive figure, framed by the space but difficult to place in depth. The prone figure is static, the only movement being the regular rhythm of his breath. Viewable for the twenty-four hours the gallery is open, he seemingly shares the immediate time-frame of the viewer while being suspended in time. Overlaid onto this very public encounter of the figure is the viewer's own reflection, and the complex reflections of the street. These are apparent even during the day, the steel plate effectively transforming much of the opening into a mirror. Yet as the viewer presses her nose to the glass, the street recedes and another, seemingly imaginary space opens up. Removed from 'real' space, this space is devoid of visual clues as to depth or scale, a displaced space onto which the viewer is invited to project her own response to the encounter with the distant figure.

5

Las Meninas

A kind of reciprocity, then: as if we on this side of the canvas and the nine characters in it were too closely engaged with each other to be segregated by the divide of the picture plane. (Leo Steinberg 1981, p. 50)

1.

Since Michel Foucault's widely referenced account of the painting in *The Order of Things* (1974, pp. 3-16), Velázquez's *Las Meninas* (fig. 29) has continued to raise complex issues about the nature of its particular *point of view*. The work has a pre-eminence in philosophical debates about representation and spectatorship. Indeed, this pre-eminence is such that it is now almost obligatory to offer some kind of apology for adding to the already substantial literature on this single work. As Elkins notes in his book *Why are our Pictures Puzzles?* the literature on *Las Meninas* continues 'to spiral, with readings building on counter-readings' (1999, p. 40).¹ Elkins cites W. J. T. Mitchell, who has called the painting a 'meta-metapicture' because it is 'an endlessly fascinating labyrinth of reflections on the relations of painting, painter, model, and beholder' (Mitchell 1994, p. 58; cited in Elkins 1999, p. 40). Elkins himself offers few answers to the question he raises, other than to note how 'we are inescapably attracted to pictures that appear as puzzles, and unaccountably uninterested in clear meanings and manifest solutions' (1999, p. 258). Perhaps an emphasis on 'interpretation' rather than the 'experience' of the work is part of the problem, inherent to the very notion of the analogy of the 'reading' of paintings. Although, as John Moffitt suggests, this is undoubtedly a work that proposes the notion of painting as 'idea' (1983, pp. 292-295), it is also a work that builds the experience of arrival into its semantic content.

Despite such misgivings about adding to the literature, it would seem remiss of me to omit from my consideration such a work, not least because its inclusion offers an opportunity to test the arguments about the structuring role for imagination against a so-called 'difficult' work. Indeed, *Las Meninas* has particular relevance here precisely because it might be seen to problematize the engagement afforded internal and external spectators. As Alpers notes, the 'size of the figures is a match for our own' (1983, p. 31), and in this respect it has something in common with Dutch group portraits, such as Rembrandt's *The Syndics* (fig. 17). Indeed, while not referred to by Riegl in his definitive account of group portraiture, Iversen observes 'it could be regarded as a demonstration



Fig. 29 Velázquez: *Las Meninas* (1656), Museo del Prado, Madrid.

piece of his principles of coordination and external coherence' (1993, p. 142). As we shall see, it likewise has an anticipated audience.

Las Meninas is, of course, a group portrait,² at the centre of which is the Infanta Margarita, attended by two maids of honour (the *meninas* of the work's title). As such, the work offers few ambiguities. But it is also a painting *about* visual representation: a concern manifest in Velázquez's own conspicuous presence as artist within the depicted scene, looking outwards towards the implied viewer. In Foucault's terms, it is a 'representation as it were, of Classical representation' (1974, p. 16). But Foucault's account also famously emphasises that in 'the definition of the space it opens up to us' there is an essential void: 'The very subject ... has been elided' (p. 16). Put simply, there is an absence of the very figures the group have (at least in terms of the fiction presented) ostensibly been gathered for. The royal couple appear only as a blurred presence in the reflection within the mirror placed centrally on the rear wall, 'a reflection that shows us quite simply, and in shadow, what all those in the foreground are looking at' (p. 15). As such, the mirror refers back to the device of Jan van Eyck's *Arnolfini Wedding* (figs. 73, 76), a work Velázquez would certainly have been familiar with, given that it then formed part of the Spanish royal collection.

But as Foucault notes, and unlike its precedent, the mirror 'shows us nothing of what is represented in the picture itself' (p. 7): it has a strange detachment, while nevertheless being central to the composition, and to the work's meaning. It is, of course, 'the reverse of the great canvas represented on the left', displaying 'in full face what the canvas, by its position, is hiding from us' (p. 10).³ Placed symmetrically around the painting's central axis, it is mirrored by that other rectangle of light within the gloom, the open doorway 'which forms an opening, like the mirror itself, in the far wall of the room' (p. 10). This introduces a further complexity, in that the doorway contains a visitor silhouetted against the bright light, poised 'like a pendulum' between coming and going (p. 11). What is the role played by this figure located outside of the studio looking in, unregistered by any of its protagonists?

Foucault suggests that the work presents surrogates, either side of the mirror, for further absences that he maintains are fundamental to the picture, that of the artist and spectator:

That space where the King and his wife hold sway belongs equally well to the artist and to the spectator: in the depths of the mirror there could also appear - there ought to appear - the anonymous face of the passer-by and that of Velázquez. For the function of that reflection is to draw into the interior of the picture what is intimately foreign to it: the gaze which has organized it and the gaze for which it is displayed. But because they are present within the picture, to the right and left, the artist and visitor cannot be given a place in the mirror. (p. 15)

Iversen suggests that for Foucault 'these absences are a structural part of the classical

episteme', in that 'the subject who classifies and orders representations cannot be amongst the represented things: man is not a possible object of knowledge. For Foucault, *Las Meninas* allegorizes this situation' (1993, p. 144). As such, Iversen suggests that:

Far from being a painting that acknowledges the spectator/artist's constitutive function, then, Foucault's *Las Meninas* actually short-circuits consideration of that position. It is painting's equivalent of Benveniste's historical utterance. Yet it must be significant that Foucault should have chosen this painting that poses so insistently the question of the viewing subject. (p. 144)

By painting himself into a composition that shows its subject only indirectly, Velázquez achieves a precarious 'sleight of hand', an allegorical equivalent of a 'classical episteme conjuring trick' (p. 145). For Foucault it is with the elided subject that 'representation, freed finally from the relation that was impeding it, can offer itself as representation in its pure form' (1974, p. 16).

Not unsympathetic to Foucault's argument, John Searle focuses his account of the painting (1980) more narrowly on the status of the mirror with respect to the displaced artist and spectator (fig. 30). Searle interprets these absences as an unsolvable paradox, in that 'the problem with *Las Meninas* is that it has all the eyemarks of classical illusionist painting but it cannot be made consistent with these axioms' (p. 483). Thus Searle maintains that the work is unprecedented in that 'we see the picture not from the point of view of the artist but from that of another spectator who also happens to be one of the subjects of the picture' (p. 483). Now it is clear that van Eyck's *Arnolfini Wedding*, in offering us the view of one of the painted witnesses to the marriage, also does just this.⁴ But, more importantly, is the claim that the painting presents a paradox well founded?

In an attempt to rule out just such a paradox, Snyder and Cohen point out a mistake common to both Foucault and Searle's accounts, in their assumption that the work's vanishing point corresponds to the mirror position. It is in fact located within the open doorway, therefore making it impossible, according to the laws of reflection, for the mirror to reflect the royal couple from the work's implicit point of view (1980, pp. 434-436). Rather, Snyder and Cohen claim that 'the reflection must originate roughly from the central region of the canvas upon which Velázquez shows himself at work' (p. 441), the implication being that the mirror thus reflects a section of the royal double portrait.⁵ In arguing that the reflection is that of the unseen painting, Snyder (in a later paper) suggests that the mirror is in fact 'the mirror of majesty': an ideal or 'exemplary image of Philip IV and María Ana, an image whose counterpart *cannot* be seen in the persons of the king and queen' (1985, p. 559). Snyder claims this as a visual trope that would have been immediately recognized by Philip himself. While the work is undoubtedly a representation *about* representation, its central paradox is therefore lost. And if, as Alpers's claims in her account of the painting, 'ambiguity remains' (1983, p. 42, n. 10), then this misses the point in that 'ambiguity is not a



Fig. 30 Velázquez: *Las Meninas* (detail).

condition of paradox' (Snyder 1985, p. 567, n. 11). Searle's paradox, as Snyder rightly notes, is not a mere oddity, but a 'logical closure', and hence 'self-referential' (p. 546). According to Searle, the artist and spectator *cannot* occupy the work's point of view because it is already occupied by Philip IV and María Ana: the painting presents the king and queen's particular perspective, not that of Velázquez or the viewer. By removing this supposed logical impossibility, Snyder and Cohen claim to remove the paradox.

2.

Now it seems to me that all three philosophical accounts thus far considered are, for all their respective insights, flawed by their failure to distinguish between the roles of internal and external beholders. It is just such a consideration that I bring to this work. Regardless of the positioning of vanishing points, Searle's and Foucault's notion that the prior occupation of the depiction point of *Las Meninas* is in itself necessarily paradoxical would suggest that *all* internal spectators are therefore, by definition, paradoxical. This is nonsensical. As we have noted, the implied internal spectator occupies an unrepresented extension of the fictional world of the painting. By contrast, Velázquez (that is the painter of *Las Meninas*, not the depicted royal portraitist) stands (or rather stood) in his studio (or, as we shall see, in an adjacent space); the spectator *of* the picture now stands within the gallery space of the Prado (though this was not always the case). Snyder and Cohen do not challenge the erroneous assumption underlying this confusion of internal and external spectators, but

merely seek to rule out a nonexistent paradox by challenging the correct placement of the work's vanishing point.

This has an immediate bearing on three questions Snyder raises somewhat sceptically in relation to Foucault and Searle's assumption that there is something unorthodox about the perspectival structure of *Las Meninas*: (i) 'Does [perspective] function in some way that it is essential to our understanding of the painting?'; (ii) 'Must an interpreter of the painting address the particular point of view that establishes it?'; (iii) 'More to the point, must an interpreter be concerned with the consequences of the work's perspective structure?' (Snyder 1985, p. 543). For Snyder, Foucault and Searle's error in locating the vanishing point invalidates their arguments, and renders these question largely superfluous to the work's meaning. And yet we can accept Snyder and Cohen's correction while maintaining an affirmative answer to all three questions. Given the role I have assigned perspective (combined with framing) in structuring our imaginative encounter with artworks, my position will not be too surprising. Indeed, I believe Velázquez is perfectly well aware of the significance of his own perspectival sleight of hand, as is acknowledged by Snyder and Cohen, who do not dispute the possibility that Velázquez might have indeed intended it to initially appear that the mirror reflected the king and queen directly. They also accept the proposition that the painting indicates '*the presence of the king and queen, in person, in the area just before the picture plane*' (p. 443), arguing that the royal presence is still the most plausible explanation for the outward glances.

In fact, the importance of the perspective is arguably more of an issue in Snyder and Cohen's account than it is in Searle's and Foucault's. The relative freedom of position we have in front of a physical work, relative to the work's implicit point of view, might explain the deliberate confusion with the mirror; and Snyder here makes a perceptive point when he notes how Velázquez paints the reverse of the slanted canvas in a way that obscures the left wall: 'Had Velázquez provided even a small part of the wall on the left, it would have been immediately obvious that the viewpoint of the picture is well to the right of the mirror' (p. 553). The resulting discrepancy, while not constituting a paradox as such, is deliberately calculated. As Damisch notes:

In this sense [of Foucault's metaphorical use of perspective] Foucault is perfectly right to see the mirror as the painting's 'center,' though ... its *imaginary* center ... If there is any representation in painting, the configuration of *Las Meninas* reveals it to consist of a calculated discrepancy between a painting's geometric organization and its imaginary structure. It is this that Foucault's critics have failed to see, as a result of their having adhered to a strictly optical, conventional definition of the perspective paradigm. (1994, p. 438)

That ambiguity is built into the work's imaginary structure is key in reminding us that the work is not something to be 'solved' through detective work, but to be experienced in

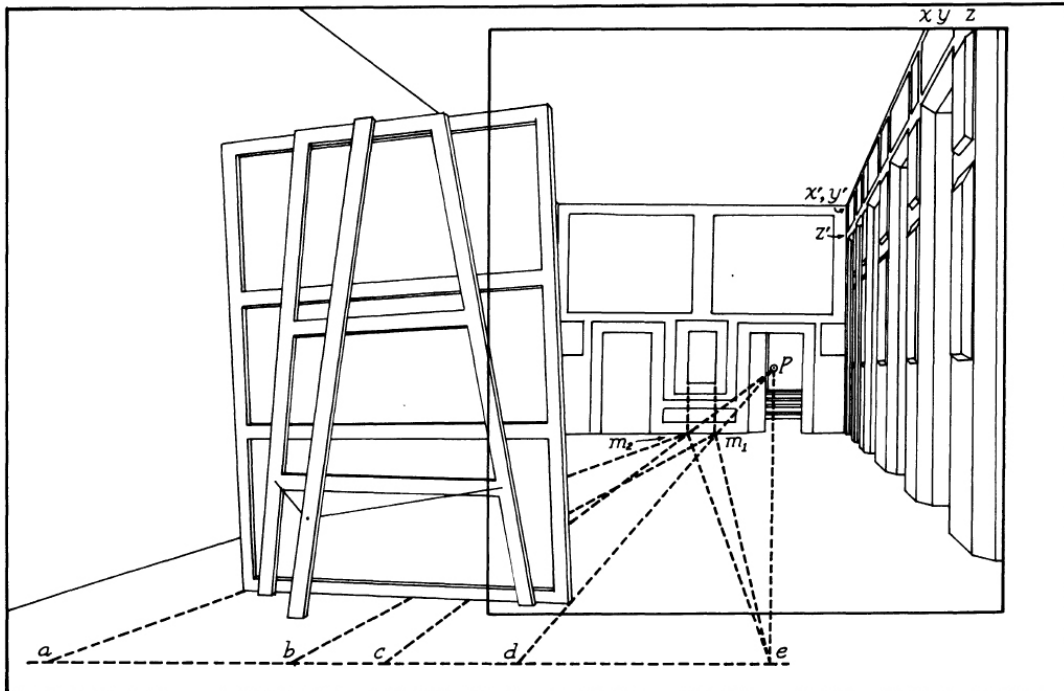

Fig. 31 Velázquez: *Las Meninas*, diagram of perspective construction, according to Snyder (1985).

its very ambiguities. In fact, as Leo Steinberg suggests, there are three centres, or *imaginary* centres, which keep shifting: the Infanta, marking the midline of the painting, the vanishing point located in the far doorway, and the mirror, placed on the room's central axis: 'the canvas as a physical object, the perspectival geometry, and the depicted chamber' (1981, p. 51).

Having said this, the painting's wider geometry *is* clearly relevant. And here Snyder makes, I believe, a fundamental error of his own in that he maintains that the king and queen stand, on axis, immediately to the right of Velázquez's canvas 'looking straight into the mirror' (Snyder 1985, p. 553). This is simply not possible, assuming (as both Snyder and Cohen undoubtedly do) that the painting is perspectively 'correct'.⁶ Snyder's own reconstruction of the work's perspective (p. 549, fig. 2) demonstrates that the painting on which Velázquez works straddles the room's central axis (fig. 31).⁷ María Ana, if not both figures, would therefore have to be tucked *behind* the depicted canvas.

The room in which the scene is staged, while destroyed by fire in 1734, can be identified with some certainty from ground plans and from contemporary accounts. John Moffitt's meticulous reconstructions of the ground plan in the Alcázar Palace and of the painting itself (1983, p. 277-283, figs. 2-4) reveal two significant facts (figs. 32, 33).⁸ Firstly, the overwhelming likelihood is that the royal couple stood (of course, in terms of the fiction presented) directly opposite the work's vanishing point, as both Foucault and Searle assume for mistaken reasons. Secondly, the viewpoint of *Las Meninas*, Velázquez's point of conception, lies *outside* of the main space, suggesting that the view was framed by an open

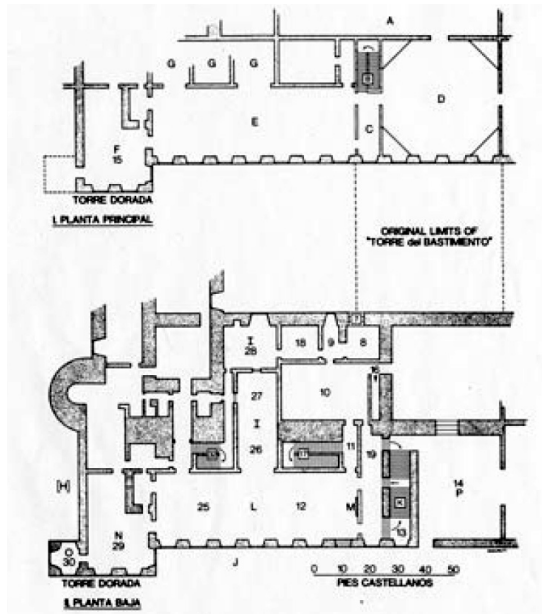

Fig. 32 Reconstruction of the ground plan in the Alcázar Palace, according to John Moffitt (1983, p. 277, fig. 2, drawn by Maria Marchetti, BFA). The upper plan shows the first floor, with the *Pieza del Despacho de Verano* (F), where the work was originally hung; the lower plan shows the ground floor, including the *Pieza Principal* (L), the room in which *Las Meninas* is staged, and the adjacent room in the *Torre Dorada* (N) from where it was painted from.

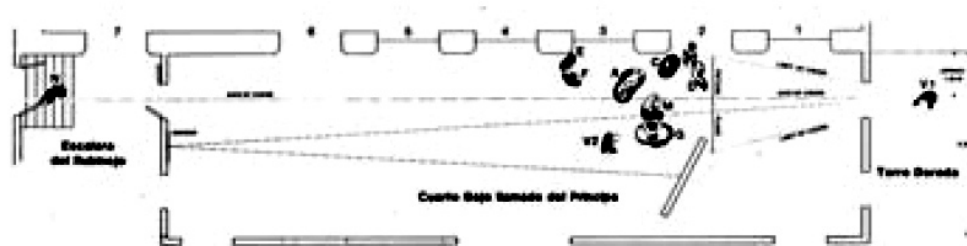

Fig. 33 Velázquez: *Las Meninas*, reconstruction of painting by John Moffitt (1983, p. 283, fig. 3, diagram and calculations by Terry L. Fox, BFA).

doorway.⁹ The likelihood is that for the fictional royal portrait the king and queen stood at the threshold of, or somewhat behind this opening. As such, it makes direct reference back to van Eyck's location of the two painted witnesses, standing in an open doorway. While an objection might be made that, unlike with van Eyck's work, there is no way of confirming this within the work itself without prior knowledge of the room, *Las Meninas* provides a clue in the reflected red curtain in the mirror (an echo of the curtain pulled back by the figure standing on the stairs). More importantly, both Jonathan Brown and Moffitt reveal that *Las Meninas* was originally painted to be hung in the 'executive office' of Philip IV (the *Pieza del Despacho de Verano*), a room in the *Torre Dorada* immediately above the room in which it was painted, or at least painted from (Brown 1986, p. 259; Moffitt 1983, p. 286). This floor replicated the precise spatial arrangement of that below, so that standing looking at the painting in its original location (fig. 32), it would have been possible to

then turn 180 degrees to look at almost the same spatial arrangement as depicted by the work itself. As Brown suggests, 'despite its size, *Las Meninas* was regarded at the time of its creation as a private picture addressed to an audience of one, Philip IV' (p. 259). The *internal* spectator correlates with the principal audience.

If, as I suspect, the notion of arrival is key, then the proposition that these figures eagerly await an arrival in the guise of either the king or queen is made more feasible by the adjacent room theory, in that the royal couple can now appear from the beholder's side of the painting at the open doorway. This would be consistent with either of the competing interpretations of the maid Isobel's posture: as a 'curtsey' (Steinberg 1981, p. 53); or as a 'leaning over to reduce parallax', the better to see the arrival of the king and queen (Searle 1980, p. 484). It is also consistent with the fact that as yet not all the protagonists have noticed the royal presence. Moreover, Brown's claim that the audience was none other than the king himself avoids the not insubstantial issues of decorum in terms of a spatial and psychological identification with the position occupied by Philip IV – this was not a work originally destined for a public gallery, but for the King's private office. However, the painting can accommodate other viewers. As Brown notes:

If this conclusion is correct, then it follows that the focal point of the picture was the king who 'interrupted' the figures in *Las Meninas* whenever he entered his summer office. The implicit assumption of his presence is recorded not only in the poses and expressions of the characters in the picture, but also in the mirror reflection. Some diagrams of the perspective locate the source of the reflection outside the picture while others identify it with the large canvas standing before the artist. This discrepancy can probably be attributed to the fact that Velázquez' instinctive use of perspective deliberately accommodates both possibilities. The purpose of the mirror is to insinuate the presence of the king (and queen) in the atelier. If the king were present in person before the picture, he could see, as it were, his own reflection in the mirror. If absent, the picture would be understood as a portrait of the infanta and her retinue, while the mirror-image would be attributed to the reflection from the easel, as did Palomino [see earlier note]. In either case, the presence of the king proved once and for all that painting was the noblest of arts. (1986, pp. 259-260)

But I would like to propose another complementary interpretation. While consistent with Brown's and Moffitt's accounts, this proposal overcomes the *apparent* paradox, which now returns, that when the king himself is *not* present in person before the work, the implied presence of the royal couple at the work's depiction point (or perhaps slightly in front of it, within the open doorway) obscures the very fictional view we are presented with. We should note that this paradox does not arise (as Searle's argument would suggest) from an internal spectatorship as such, but from the inappropriateness of any intended identification with the king or queen. My proposal is founded upon the premise, implied but not fully elucidated by Brown's account above, that there is no reason to assume that in the fictional scene presented by *Las Meninas* the royal couple need be present at the moment the painting depicts. If the reflection in the mirror is *not* that of the king and

queen, but the painting on which Velázquez works, then they really might be *absent* as the elided subject.

But then whose view, if any, is thus presented? As Steinberg states, we certainly do not *feel* excluded; but are we still, as he suggests, 'part of the family, party to the event' (1981, p. 48)? Well, Steinberg's speculation as to whether we have 'just walked in to interrupt them' (p. 50) is alternatively explained if we identify ourselves *not* with the remote and distant royal couple, but with the palace steward who would surely have preceded them, in order to announce their imminent arrival. This intriguing possibility would directly 'mirror', along an axis from viewpoint to vanishing point, the presence and actions of the figure in the far doorway, who we know to be *another* Velázquez, don José Nieto, steward to the Queen. One of his roles was precisely to open the doors for the king and queen. Perhaps in this identification with a corresponding figure unambiguously *within* the work, we likewise pull back a curtain to prepare for Philip IV and María Ana's eagerly awaited arrival. This would provide an internal spectator entirely consistent with the fiction presented, meeting any objection about prevailing decorum. Paralleling the otherwise curious presence of the figure in the far doorway, it offers a considerably less onerous psychological repertoire for viewers *other* than the king to identify with.

But I also believe we can identify with a spectator internal to the *other* painting: not the fictional painting of the royal portrait, which we see only in the mirror as the *reverse* (in two senses) of the depicted canvas, but to the group portrait that confronts us, posed and organized by Velázquez. Despite his presence *within* the work, perhaps Velázquez is inviting us to identify with his position painting the very work before us. (Of course, Velázquez's responsibilities with respect to the royal painting collection would have made him a frequent spectator of the work.) If the painted 'visitor', located at the work's vanishing point, mirrors a steward arriving, he might also be said to mirror Velázquez himself. Not only do they share a name, but as Damisch notes this figure also seems to mimic the very posture of an artist (1994, p. 436). Brown's and Moffitt's adjacent room theories would add weight to Damisch's notion of a mirroring along this access between viewpoint, the work's point of conception, and vanishing point (though whether this refers back to the *origin* of perspective, as Damisch suggests, is questionable). Velázquez, the painter of *Las Meninas*, is likewise positioned *behind* a threshold, looking in. If the *other* Velázquez is likened to the spectator position in one painting, he is also linked to the point of origin of the other. If, as Foucault observes, the whole painting, like Velázquez's stance, brush held mid-air, is, itself, *suspended* (1974, p. 3), then perhaps we are asked to identify, from its point of origin, with the suspended encounter that painting provides.

Intriguingly, each of Foucault's absences - king and queen, artist and spectator - are thus provided a possible place, through spectatorships internal to the *two* respective works presented: that of the painting of the royal portrait and that of the staging of *Las*

Meninas itself. Far from excluding us, while the work may offer a very specific 'internal' spectatorship limited to the king (or queen), it also offers other potential spectators with which to identify with, unrepresented counterparts to Foucault's surrogates depicted either side of the elided subjects presented by the mirror. Not a paradox as such, in that each encounter has its own consistent internal logic, but a choice of potential imaginative identifications.

And here it is worth noting that, regardless of competing interpretations, the role of imagination is fundamental to the reciprocity implied by all of these possible identifications; moreover, while these encounters are undoubtedly *internal* to the work, structured by the work's framing and perspective, the genius of Velázquez (and at least one of the reasons this is such a great work) is that they are given added psychological charge by the viewer's own *physical* sense of arrival and engagement in front of the work (the same device used by Rembrandt's *The Syndics*). While not integrated into its architectural context in quite the sense of *Trinity*, the work (especially in its original location) draws upon our positioning in space relative to the virtual world it presents. It has a processional dimension, not as Brown suggests in terms of its iconography or interpretation, but in terms of an experiential ground. And as Steinberg suggests, it presents an encounter where we experience:

A kind of reciprocity, then: as if we on this side of the canvas and the nine characters in it were too closely engaged with each other to be segregated by the divide of the picture plane. Something we bring to the picture – the very effectiveness of our presence – ricochets from the picture, provokes an immediate response, a reflex of mutual fixation evident in the glances exchanged, the glances we receive and return. (1981, p. 50)¹⁰

3.

If, as both Brown and Moffitt suggest, this is a work that claims painting as 'a legitimate form of knowledge' (Brown 1978, p. 109), where 'painting is the demonstration of a mental concept, or "idea"' (Moffitt 1983, p. 292), then it does so in a way that incorporates the presence of an individuated viewer into its semantic content. Idea and reciprocity - dependent upon an imaginative identification - fuse. The notion of *two* paintings might be reconciled with Alpers's proposal that the work describes two modes of engagement, though I would question her claim that they are presented in a 'fundamentally unresolvable way' (1983, p. 37). Rather, they offer parallel, but not incompatible, ways of experiencing the work – different 'uses' of the work as imaginative prop.

Alpers contention is that *Las Meninas* constitutes 'a conflation of the northern mode (the world prior to us made visible) and the southern mode (we prior to the world and commanding its presence)' (1989, p. 70). Following, Puttfarcken's point about scale, noted earlier, I would argue that such differences are perhaps less to do with geographical boundaries (despite some correlation) and more to do with the divergent notions of internal

and external spectatorship I have been presenting. If *Las Meninas* can be said to embody two modes of engagement, *it is because it is in fact two distinct works*. The fictional narrative of the painting of a royal portrait presents a self-contained world that is ambiguous only in the sense that we imaginatively access this world through two logically consistent but competing internal identifications: one aimed at the king, one at other visitors to the work. Here the artist is, as Alpers suggests, 'accounted for ... within that world' (1983, p. 37). But if we take the work to be an identification with the painter of the group portrait revealed as an event 'staged' by Velázquez, then the commanding of the presence in *Las Meninas* is a direct identification not with Velázquez's position *in* the work, but in *front* of it. Here, as Alpers suggests, 'the artist presumes himself to stand with the viewer *before* the pictured world in both a physical and epistemological sense' (p. 37).

And there is an ingenious final twist, in that while the work does not draw the surrounding architecture into its domain in the manner of *Trinity*, there is a kind of fusion in both identifications between internal and external spectators. While entirely consistent with Wollheim's arguments for a spectator *in* the picture, the work's double manifestation also provides *something* of the direct physical encounter I have described with *Trinity*. In one mode, it draws the viewer's physical experience of arrival into the imagined encounter: whether that viewer is the king or some other spectator. In the other mode, while we imaginatively identify with Velázquez's position in a way that is internal to the world it presents, we also identify with the artist in a way that draws on our physical presence *not only* in terms of 'commanding' the staged scene as 'idea', but in terms of our presence before the picture as physical, and sublimely tactile, object.

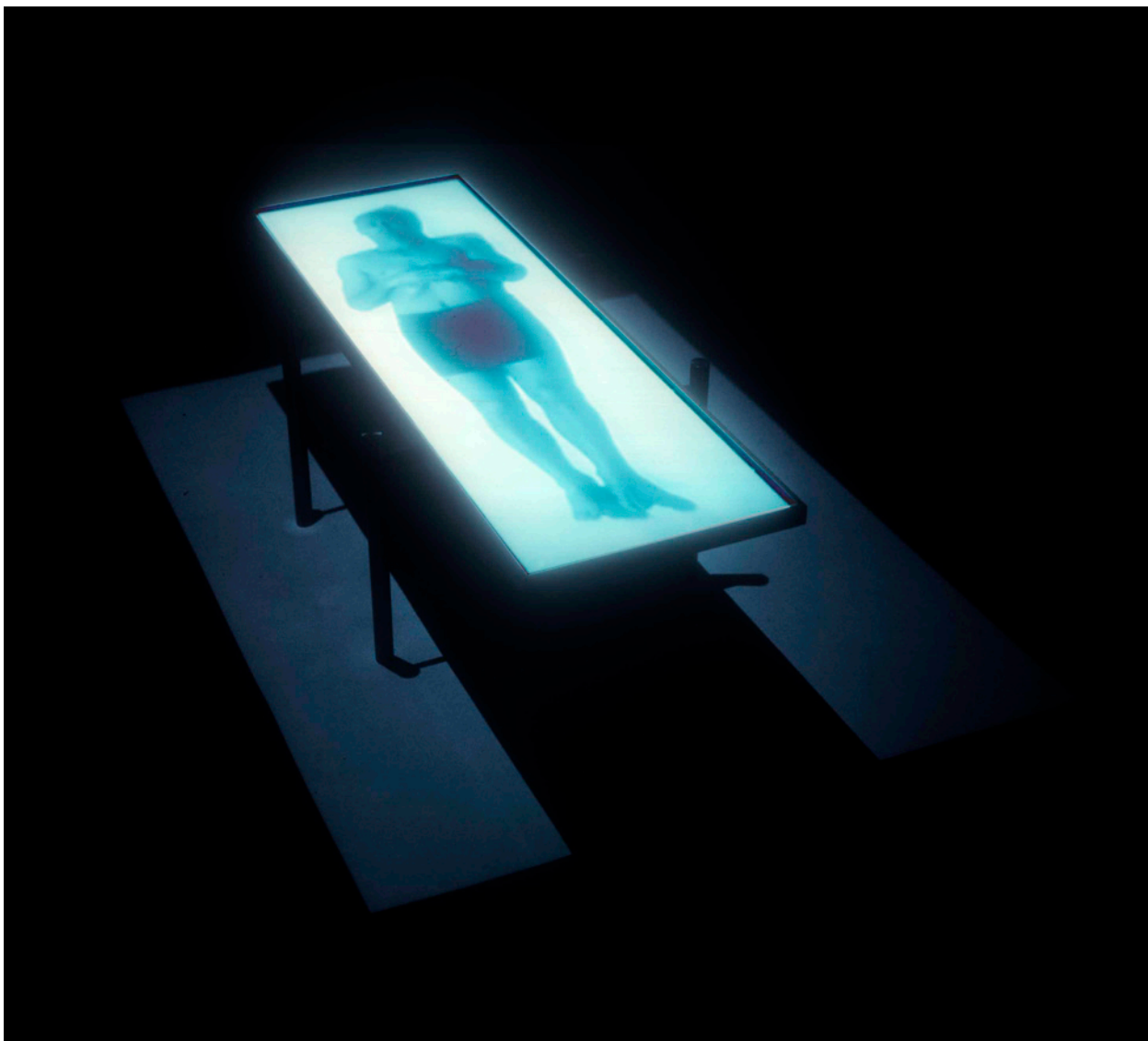

SUSPENDED

2002

A shallow steel tray, 840 x 280mm, is supported by a simple metal construction. The table-like structure is very low, just 280mm high. The tray is filled with a thin 12mm layer of water, which is not immediately apparent upon entering the space. A prone figure, filmed from above, is projected onto the tray's milky-white acrylic lining. Placed within a darkened space, the viewer looks down onto this low table and diminutive figure, unaware of the presence of the water due to the strength of the projected light. The figure's only movement is revealed by the slight rise and fall of his chest. Like a child's chair, the object is curiously sized: neither a full-sized table nor scaled model. In a darkened space, the effect is of looking down at the object from a considerable height. Installed in a room with a timber floor, the table structure is highly susceptible to movement, causing the water it contains to vibrate as someone approaches the work. A shadowy, reflection of the projected figure (almost impossible to photograph) is cast onto the gallery ceiling, across which wave-forms reveal both a spectator's presence and the water into which the acrylic sheet is submerged. Unlike the source of the reflection, this figure is life-sized. The reflection registers as an 'out of body' spectral presence, hovering above the head of the viewer.

6

A Displacement Device

The problems, both technical and theoretical, posed by the depiction of an apparition or a miraculous ascension, an aerial transportation, or even a celestial gathering on a two-dimensional plastic screen – those problems are by no means secondary or subsidiary in relation to the enterprise that, according to a strongly established tradition, epitomizes the Renaissance’s contribution to the development of Western art and civilization: namely, the institution of the system for representing space that is known as linear perspective. (Damisch 2002, p. 82)

1.

In the *Ecstasy of St Francis* (fig. 34),¹ from the Upper Church of the Basilica of San Francesco, Assisi, the Saint, enveloped by cloud, hovers between the heavenly and earthly realms. As Damisch notes in his *A Theory of /Cloud/*, the ‘cloud introduces a break into the fabric of dramatic and theatrical relations: it removes the saint from the common space and makes transcendence appear as an antithesis in a representation conceived in strictly “human” terms’ (2002, p. 101). Cloud is used as a signifying element within a pictorial structure that is characterised by a shallowness of space - what Panofsky refers to as an aggregate space (1991, p. 63). It is the signifying role of cloud that establishes the separation of supernatural and mundane realms. Given that the viewer’s position remains largely undefined, this separation does not as yet impact upon the beholder’s implied relationship to the virtual space of the painting. Damisch argues that ‘From the motif (of cloud denoted by a signifier made “in its image”) one moves, again with no break in continuity, to the *theme* (the miraculous vision, the opening up to divine space)’ (2002, p. 20). As with Giotto’s *Ascension* (fig. 35), from the Arena Chapel in Padua, it is the motif of cloud that here resolves the essentially two-dimensional division of the picture into different realms.

The integration of the supernatural element into a shallow pictorial space is thus realized primarily through symbolic means. But perspectival representation introduces its own difficulties with respect to depicting the supernatural. As Goffen notes, ‘Naturalism or Realism is not necessarily suited to the supernatural themes of Christian art’ (1998a, p.2). With the shift from a late medieval aggregate space to the ‘systematic’ space of perspective, painters faced a real problem in how the supernatural might be plausibly depicted within the latter’s unified spatial logic.² As we have noted, it is a logic that includes the implied location of the viewer relative to the pictorial space. While such positioning *is* a factor with some late Giotto works,³ the viewer is not located with any kind of precision. But



Fig. 34 *Ecstasy of St Francis* (c. 1274-84), Upper Church, Basilica of San Francesco, Assisi.



Fig. 35 Giotto: *Ascension* (c.1305-1310), Arena Chapel, Padua.



Fig. 36 Masolino: *Foundation of Santa Maria Maggiore* (c. 1428-32), Museo Nazionale di Capodimonte, Naples.

for those perspectival works establishing a spatial continuity between real and fictive space, the implied presence of the beholder has a fundamental impact upon strategies for representing the miraculous within such an implied continuum and spatial proximity.

As Damisch demonstrates, the use of signifying elements to depict the miraculous persists throughout the Renaissance and into the Baroque. But from Masaccio onwards, this is supplemented by new spatial strategies deploying specifically perspectival means to depict the supernatural realm. These complement, and sometimes supersede, earlier models. It is fundamental to my argument that, unlike the Giotto model, these spatial strategies are dependent for their effect upon the kind of imaginative engagement I have termed *seeing-with*, in terms of (i) providing a vivid experience of pictorial depth, and (ii) facilitating a reciprocity between scene and beholder that draws upon nonconceptual content. Many of the examples I therefore draw upon in this chapter constitute a specific application of the engagement afforded by the imagination, in that the distancing devices they utilize in turn depend upon an implied proximity and spatial uncertainty.

2.

Masolino's *Foundation of Santa Maria Maggiore* (fig. 36) offers what now seems a rather amusing early attempt to subject the vaporous element of cloud to the foreshortening characteristic of perspective; yet the painting still relies on a combination of aureole and cloud, 'read' as signs, to effect the required separation of earthly and heavenly realms.⁴ This

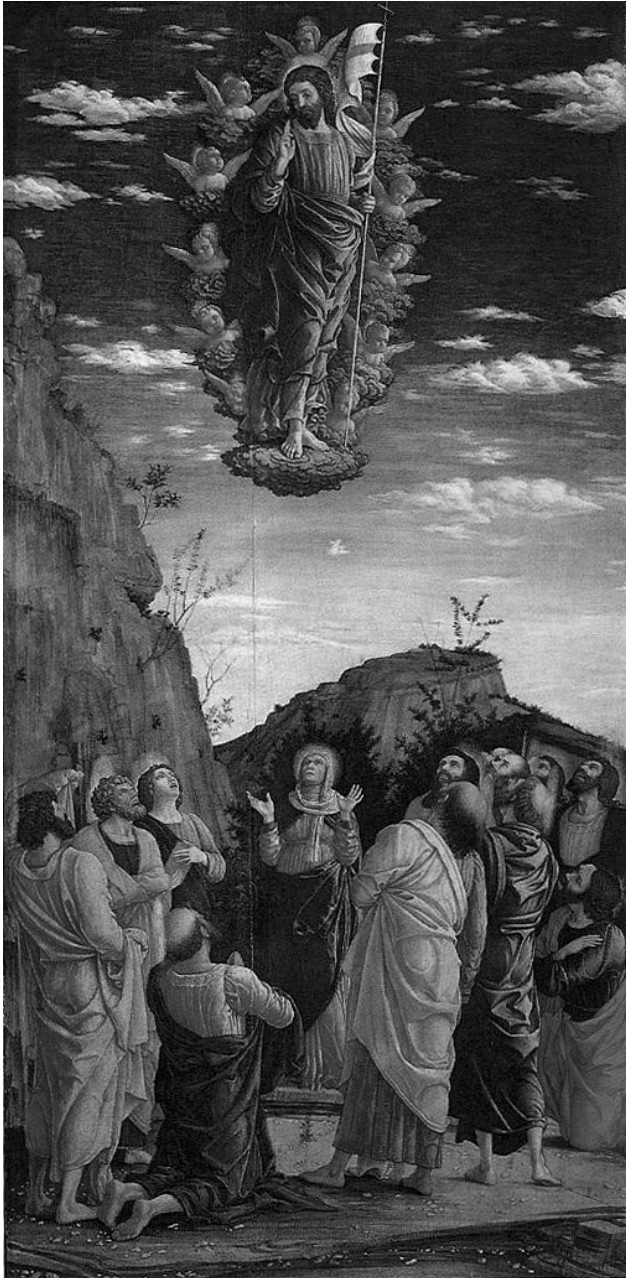

Fig. 37 Mantegna: *Resurrection* (c. 1462-64), Galleria degli Uffizi, Florence.

separation is primarily registered in terms of the essentially two-dimensional organisation of the picture surface, rather than in terms of pictorial depth.⁵ The same is essentially true for Mantegna's Uffizi *Resurrection* (fig. 37), where, despite the greater apparent realism, the enclosing hills limit the work's implied depth. Mantegna sharply distinguishes between the stylised clouds, which bear the weight of Christ, and the realistically rendered atmospheric clouds of the work's background. The former, along with the cherubim, delineate an enclosed mandorla, establishing the requisite separation.

Giovanni Bellini, by contrast, makes no such distinction in his later version of the *Resurrection* (fig. 38), from the Gemäldegalerie, Berlin, abandoning stylised clouds. Christ, while loosely associated with the naturalistic clouds in the background, rather disconcertingly ascends, defying gravity. He has no visible means of support. The disquiet follows from the implication that Christ floats in an undifferentiated space: cloud, *as*

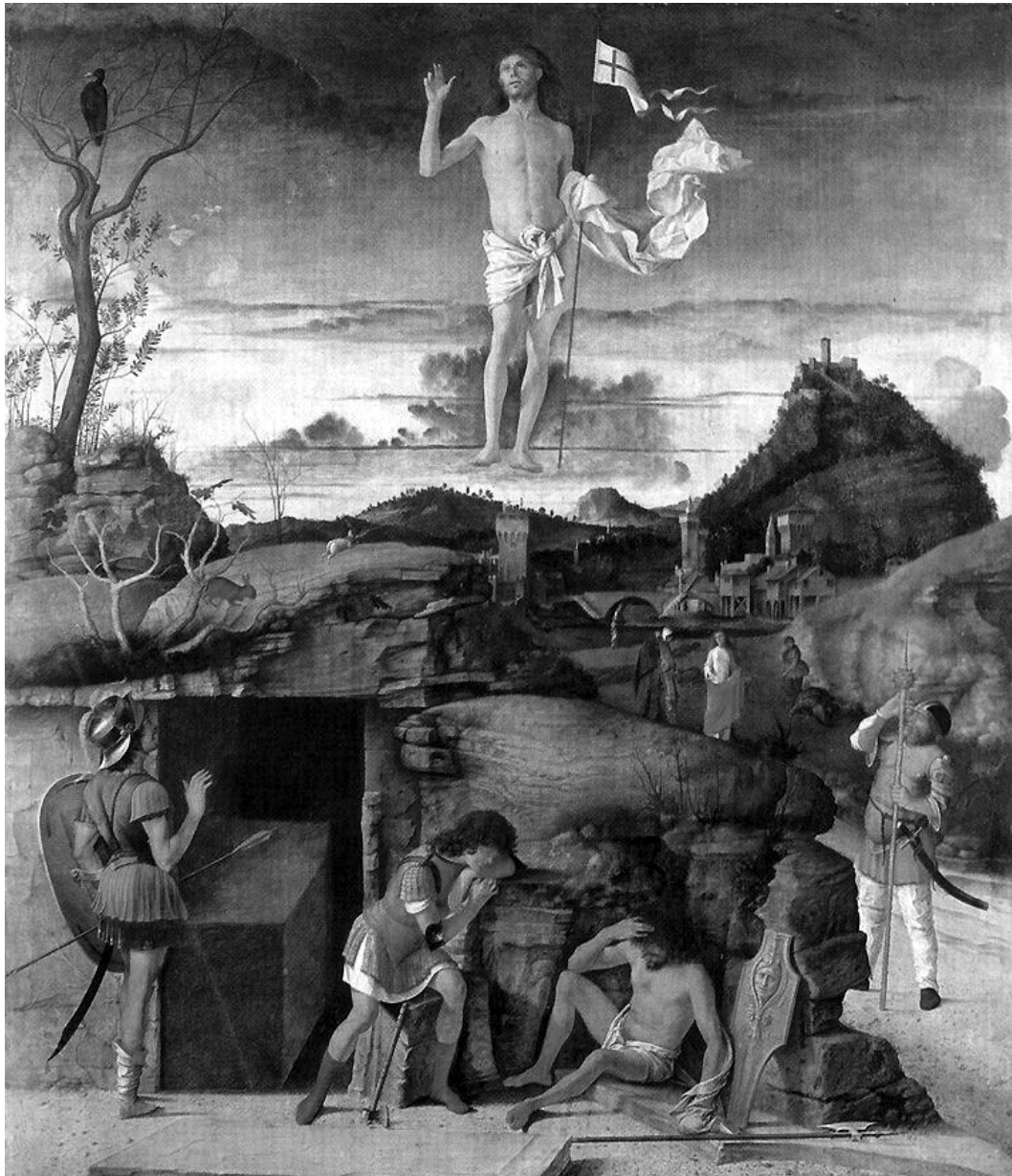

Fig. 38 Giovanni Bellini: *Resurrection* (c. 1479), Gemäldegalerie, Berlin.

sign, no longer functions as support or spatial marker (in much the same way that Bellini relinquishes the need for Christ's halo). And yet His position introduces a new ambiguity, in that perspectival cues to Christ's location are withheld. As Goffen notes of this work, 'Christ is not – cannot be – delimited by spatial boundaries' (1989, p. 143). Bellini's radical model is taken up by Titian in his *Brescia Polyptych of the Resurrection* (fig. 39), although here the close cropping of the image alleviates much of the apparent strangeness of Christ's ascent.

Contrary to Masolino's attempt to do so, it is the fact that *cloud defies perspectival means to represent it* that allows it to persist as 'a constructional ploy ... to introduce a divine group or symbol into a perspective construction' (Damisch 2002, p. 42). For Damisch, cloud serves the role of perspective's 'necessary counterpart' (p. 82). Indeed, cloud – combined with divine light – plays a pivotal role in Baroque ceiling painting. As Wölfflin argues,



Fig. 39 Titian: *Polyptych of the Resurrection* (1520-22), Santi Nazaro e Celso, Brescia.

such painting reveals ‘a completely new *conception of space directed towards infinity*: form is dissolved in favour of the *magic spell of light* – the highest manifestation of the painterly’ (1964, p. 64).

Correggio’s *Assumption of the Virgin* (fig. 40) might serve by way of example. Here, the octagonal domed ring, part of the real architecture of Parma Cathedral, opens up onto a virtual space that, in contrast to the space the viewer occupies, is unbounded or infinite: an amorphous or nebulous ‘celestial’ space that abandons architectural definition and perspectival representation. There is a radical asymmetry between the fictive and viewing space, although the work still orientates itself towards an ‘instinctive’ viewpoint, a position that Shearman observes is ‘at the bottom of the steps’ that cross the nave just prior to the western supporting arch (1992, p. 186). The threshold between realms is seen as one that calls into question the very reality of the supporting architecture. As Damisch notes:

The solution associated with Correggio amounts to a negation: of the building itself, and even of the fact that it is a closed space. This effect is created on a key part of its overarching cover, by a decor conceived in such a way as to ‘pierce’ the stone fabric and create a fake opening onto a sky that is itself painted in *trompe l’oeil*. (2002, p. 1)

And yet the work is dependent for its experiential impact upon the very architecture it seeks to negate. The viewer (that is the *external* beholder) is situated by the processional



Fig. 40 Correggio: *Assumption of the Virgin* (1526-1530), Parma Cathedral.



Fig. 41 Correggio: *Vision of St John* (1520-24), San Giovanni Evangelista, Parma.

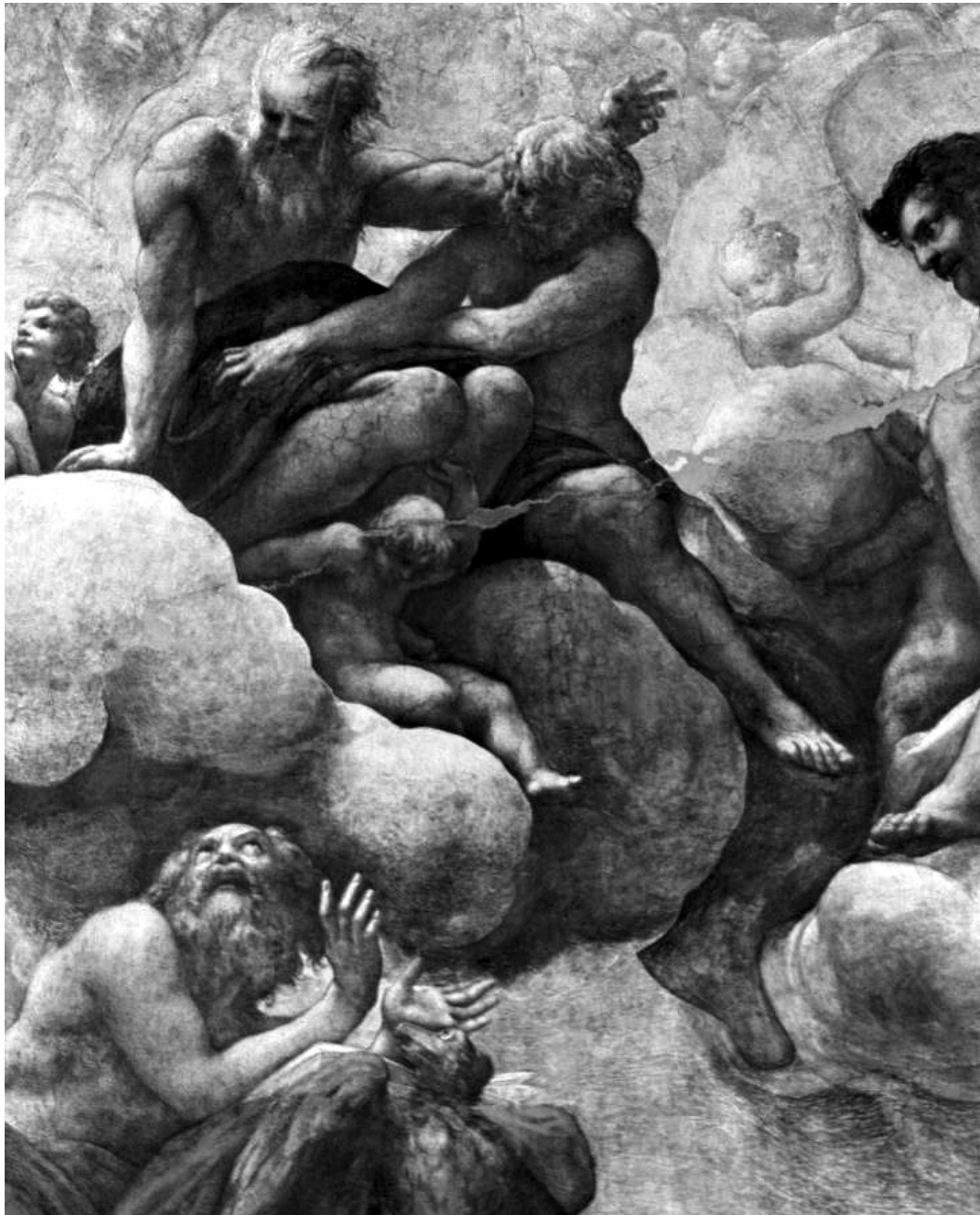

Fig. 42 Correggio: *Vision of St John* (detail).

demands of the physical building, and the painting draws this religious architecture into its content.

As such, to repeat an earlier argument, I believe it is a mistake to assume that Correggio's intent is purely, or even primarily one of illusion; rather, while undoubtedly utilizing illusory devices, such paintings draw upon the imaginative consent of the viewer, whereby the spatial schemata is allied to the works' religious content. This is illustrated by Correggio's *The Vision of Saint John* (fig. 41), which similarly creates a fictitious opening onto a celestial realm. As Shearman observes, two viewing positions are implied: a position in the nave of San Giovanni Evangelista, Parma, where Christ – in His second coming – floats in a way that is consistent with the heavenly perspective, the viewer a direct recipient of the vision; and a second position (fig. 42), which is reserved for the Benedictines in the choir,

a viewpoint from which Saint John, obscured by the overhanging cornice from the nave, is revealed as the original recipient of the vision, in a less emotionally charged but more intellectually demanding experience of the scene (1992, pp. 183-184). This integration into the ceremonial functioning of the architecture acknowledges *differentiated* viewers, belying the notion of a work that is simply to be experienced as a *trompe l'oeil*.⁶

3.

If, as Damisch suggests, *cloud* remains 'a key term in the figurative vocabulary of Correggio', then it is a theme that, 'contradicts the very idea of outline and delineation and through its relative insubstantiality constitutes a negation of the solidity, permanence, and identity that define *shape*' (2002, p. 15).⁷ Yet while the signalling role of cloud is retained, I would argue that the spatial impact of Correggio's ceiling paintings is dependent upon situating a spectator within an architectural context that *frames* the fictitious celestial space. While cloud functions as the very antithesis of perspectival construction, the affect follows from Correggio's successful integration of the threshold between realms into both host architecture and fictional space, into the painting's inner and outer apparatus. As Shearman notes, with Correggio's *Assumption of the Virgin* 'the assertion of the continuum between the spectator's space and the pictorial space, through the visible bodily Assumption from one to the other, is the most complete statement possible of the transitive relationship between dome and viewer' (1992, p. 188). This is entirely consistent with the type of relationship that I have argued is afforded by works implying an external spectator as part of their content.⁸ This imaginative engagement, which draws in the spectator's awareness of the surrounding architecture, is key to the emotional affect of the dramatic rupture of such a situated relationship that the fictitious opening onto the celestial realm represents. This is not the mere 'reading' of signs, but a dynamic *interaction* between fictional space, host architecture, and an embodied viewer.

4.

The strategy adopted by ceiling painters can also, of course, be applied to the upper sections of wall painting. In so doing, Pintoricchio's Bufalini Chapel applies two contrasting strategies to the representation of the supernatural within the same space: one using primarily symbolic means, one applying a spatial strategy that is dependent for its effect upon locating the viewer in real space. The comparison proves useful for the distinctions I am drawing in this chapter.

The chapel is a space onto which Pintoricchio overlays an unprecedented false architecture, a painted architecture that unifies a variety of different approaches to constructing a relationship between pictorial space and beholder. As Sandström notes of Pintoricchio's design of the chapel:

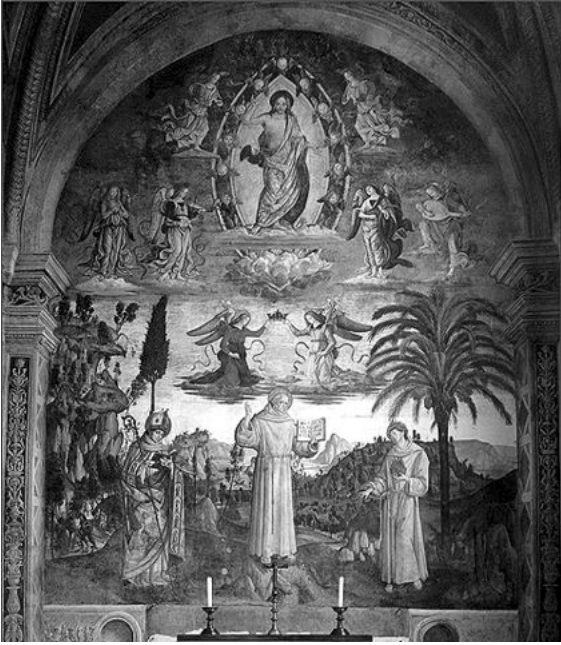

Fig. 43 Pintoricchio: *San Bernardino in Glory* (1482-85), Bufalini Chapel, Santa Maria in Aracoeli, Rome.



Fig. 44 Pintoricchio: West Wall (1482-85), Bufalini Chapel, Santa Maria in Aracoeli, Rome.

Above all he abolished the boundary, common until his time, between the figurative and merely decorative parts of a picture, without thereby causing a weakening of the structure of his painting. The principal method for his integration – which permits of a no less complete classification of the main sections of the decoration – is the conscious use of different degrees of reality in different parts of the picture, and an interaction between different planes of reality. (1963, p. 42)

Marilyn Lavin, referencing Sandström's account, claims Pintoricchio's approach as 'a major departure in the field of mural disposition', by which the painted pilasters are moved forward 'to the surface of the field', thereby 'transforming them into a frame for the whole area' (1990, p. 215). She refers to the resultant 'opening up of the pictorial format' as 'the "Expanded Field"', arguing that 'its implications for the expression of new complexities in religious devotion, as well as penetration into new depths of psychological experience, were to characterize cycle painting for the next two decades' (p. 215).

My concern here is not with developments in narrative cycles, but with the contrasting approaches to the representation of the celestial realm offered by the right-hand and altar walls of the chapel. On the altar wall, *San Bernardino in Glory* (fig. 43) presents a unified image that refers back to earlier models for incorporating the celestial realm; despite the painted frame, there is little sense of a spatial continuity, or of any great pictorial depth. Flanked by two Franciscan saints, San Bernardino 'displays his book and points to Christ, who appears above in a mandorla' (pp. 217-218). Both mandorla and supporting clouds signify their role, while the painting divides into two distinct sections - the top half of which is 'thus not narrative but devotional' (p. 218). As Sandström notes, this upper section of the picture 'appears as a vision, both in relation to the three saints below and their landscape, and in relation to the observer' (1963, p. 73). Lacking real spatial depth, it nevertheless has 'a reality of its own', whereby the vertical division stresses 'the boundary, or the incongruity, between the real spatial sphere of human existence and that of the vision' (p. 73).

By contrast, on the right wall (fig. 44) Pintoricchio integrates a real window, the source of everyday light that enters the chapel, into the 'illusionistic' painted architecture, dramatically blurring the boundaries between the fictive and real. While the lower panels make no attempt to construct a relationship with the beholder, Pintoricchio incorporates two painted windows, with 'perspectivized jambs that rest illusionistically on the painted cornice' (Lavin 1990, p. 217). These false windows 'open' onto a heavenly realm beyond. The suggestion is that this realm continues *behind* the real window, transforming the light that enters the chapel into a celestial light. As with *Trinity*, elements, such as the peacock are painted as though they intrude into our space. But the most important incursion happens through the left of the two painted windows, where God the Father (surrounded by cherubim) dramatically 'enters' from the supernatural fictive realm into the very space of the chapel itself. As in the later Correggio ceilings, the beholder's experience of the real

space is drawn into the experience of the divine presence, supplementing the symbolic devices. In sharp contrast to the primarily signifying means utilized by the altar wall, here perspectival and spatial means combine - with the spectator's sanction - to frame such a presence, and the celestial realm from which God emerges. And it is an experience that rests upon the overlaying of a fictional architecture onto the space of the chapel.

5.

In previous chapters we have noted how Masaccio's *Trinity* (fig. 2) structures a metaphysical distinction between different parts of the fictive realm, and allies this distinction to its religious content. *Trinity*, however, includes a further gradation in reality, which is noted first by John White, and is picked up upon by, among others, Bryson.

If the religious representation 'behind' the picture surface is itself differentiated from the viewer's reality, the *Trinity* (which exists *outside* of time) involves a further ambiguity as to its placement in space (fig. 45), and conforms to a viewing position located far above our heads, 'in a zone the body of the viewer cannot occupy' (Bryson 1983, p. 108). Bryson refers to this as a 'post-Albertian point', a 'theoretical punctum' which contrasts with the empirical perspective of the first vanishing point.⁹ White, by contrast, explains it away pragmatically as Masaccio's refusal to excessively foreshorten the figures of Christ and God (1972, pp. 139-140). I would argue, however, that it is an astonishing conceptualization of the very real problem that I have been arguing faced early Renaissance painters, and constitutes a distinct mode for depicting the supernatural within the unified space of perspective. Allowing the cultic presence an independence from spatiotemporal markers that locate the external beholder, Masaccio devises a fundamentally new method for implying a necessary distance within an unprecedented proximity: *a proximity which directly results from the activating of the beholder's space*. The 'visionary' impact of such a spatial and temporal displacement refers back to earlier traditions of Christian art, while also registering the effectiveness of new perspectival means to relate the virtual space of the painting to the actual church architecture. It offers a spatial metaphor to match the symbolic message of the representation of the *Trinity*.

I do not claim to be the first to note this, but I believe the role of *seeing-with* intensifies the significance of Masaccio's strategy. As Goffen has observed:

Removed from time, the *Trinity* is also removed from space, and despite Masaccio's dazzling perspectival illusion (or rather because of it) one cannot say with certainty where God the Father actually stands with his crucified Son. In other words, there is no precise answer to the question, 'Where exactly is the *Trinity* in Masaccio's *Trinity*?' (1998a, pp. 22-23)

It is only by integrating the work's frame into its architectural context, and into both its inner and outer apparatus, that the inherent difficulty in saying 'where the painting

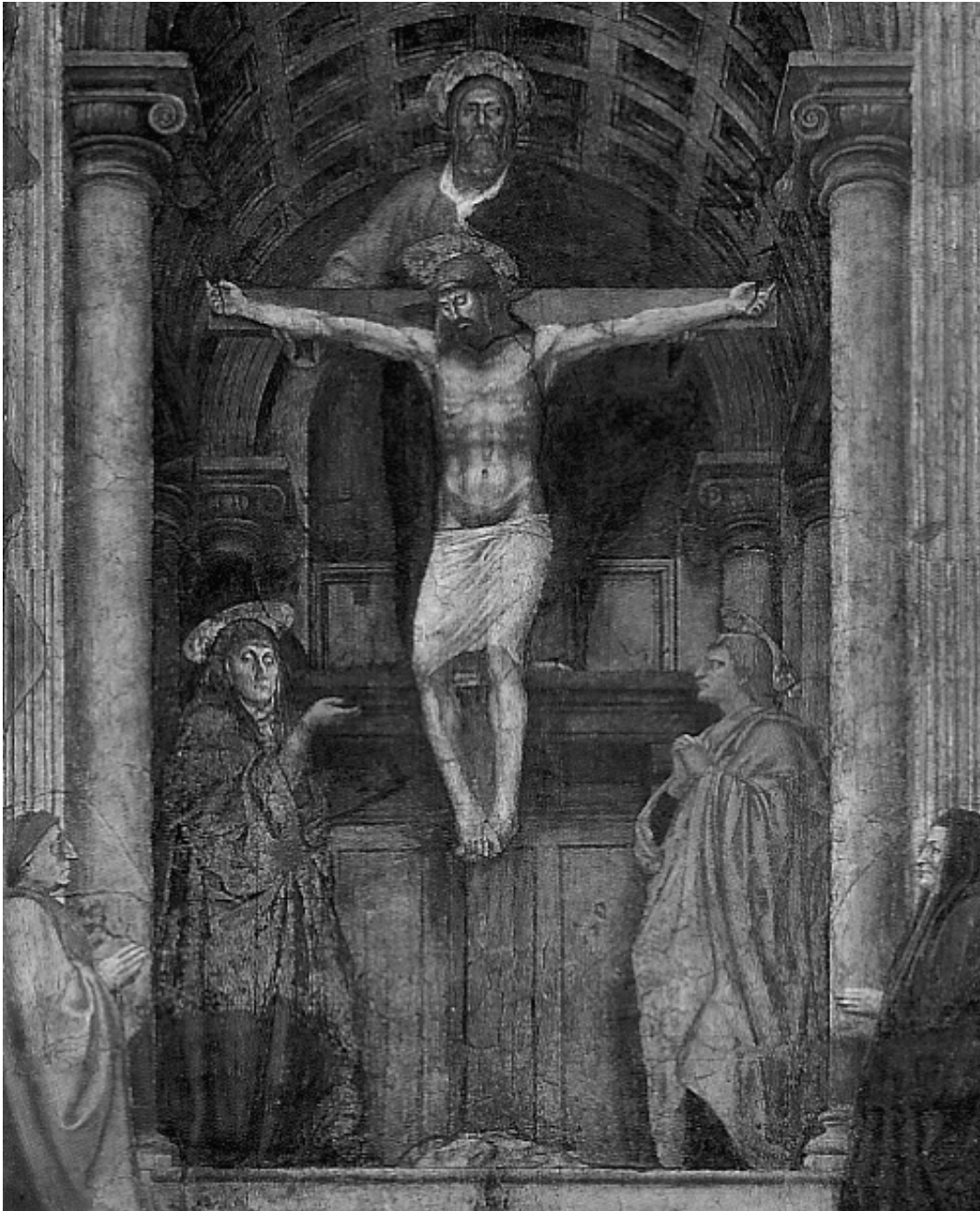

Fig. 45 Masaccio: *Trinity* (detail), Santa Maria Novella, Florence.

is' can be applied to a discrete fragment of the painting associated with the Trinity. This ambiguity exploits an anomaly of perspective: that while it can locate with precision an object in pictorial space, it can also withhold the necessary cues required to reconstruct this position. (We have already noted this in relation to Bellini's *Resurrection*.) This is why attempts to reconstruct the space of *Trinity* miss the point.¹⁰ As Goffen notes: 'Certainly, this spatial imprecision is purposeful, and its purpose is to place the Trinity beyond spatial limits and constraints, literally immeasurable, ultimately and profoundly mysterious' (p. 23). It is therefore no coincidence that, as noted earlier, *Trinity* occludes its horizon. It is the deliberate withholding of the vital information necessary to locate the Trinity in space, combined with the insistent frontal depiction of Christ and God, that introduces the required ambiguity of positioning in space – a device entirely dependent upon an otherwise

strongly felt spatial continuum, and a *situated* beholder. The Trinity thus occupies another realm, another reality: an impact that is particularly apparent from a kneeling position, from a height that (particularly for a contemporary viewer) removes us from our normal spatial relation to painting.

In contrast to the use of cloud *as* sign, this is a solution that uses means entirely internal to the system of perspective in order to depict states *beyond perspectival means of representation*. As a break from the so-called 'mathematical space' of perspective (and yet not inconsistent with its internal logic), it constitutes a spatial equivalent to the role Damisch argues cloud plays, as perspective's 'necessary counterpart'. A discrete space is opened up within the painting, a visionary 'gap' in reality (the 'unrepresentable'). Such a displacement is dependent for its impact upon the implication of an inviolable, sacred or dream-like space to which we are excluded, both spatially and temporally. This impact, in turn, is dependent upon the kind of situated relationship and implied continuity described in the previous chapters. In other words, the impact of such a spatial displacement is predicated upon the imaginative (rather than illusory) engagement of an external beholder, an embodied presence *where the internal and external spectators fuse*, blurring the boundaries between real and fictive, inner and outer reality. If this situating of a viewer is largely achieved through a work's framing, combined with perspective, then the subsequent spatial ambiguity follows from the concealment of the very means by which perspectival depth is implied, and by a corresponding rupture between such a displaced space and the work's bounding frame.

6.

Some other examples might now help concretize the argument. Perhaps the most extreme construction of a secondary viewpoint is Andrea del Castagno's *The Trinity Appearing to St Jerome* (fig. 46), the top section of which includes an extraordinary view of the Trinity as if seen from above, from Heaven itself. The impact of the Corboli Chapel painting would have perhaps been even greater without the two child-seraphim, a late addition that, according to Frederick Hartt, 'were added *a secco* and have partially peeled away' (1987, p. 267). Hartt surmises that 'possibly the clergy were offended by the audacity of Castagno's foreshortened Trinity and required this addition' (p. 267). And yet while this might arguably appear as a more radical departure from a consistent perspective than Masaccio's *Trinity*, this later work nevertheless utilizes new perspectival means in a way that is more obviously consistent with earlier models in terms of the work's surface disposition. Unlike the Masaccio, it does not directly engage our implied participation. However, as Podro notes, 'the embedding of one perspective within another' does again register 'divine intervention' (1998, p. 49).

Mantegna's *Assumption* (fig. 47) in Padua is more directly related to Masaccio's model.



Fig. 46 Andrea del Castagno: *The Trinity Appearing to St Jerome* (c. 1455), Corboli Chapel, SS Annunciata, Florence.

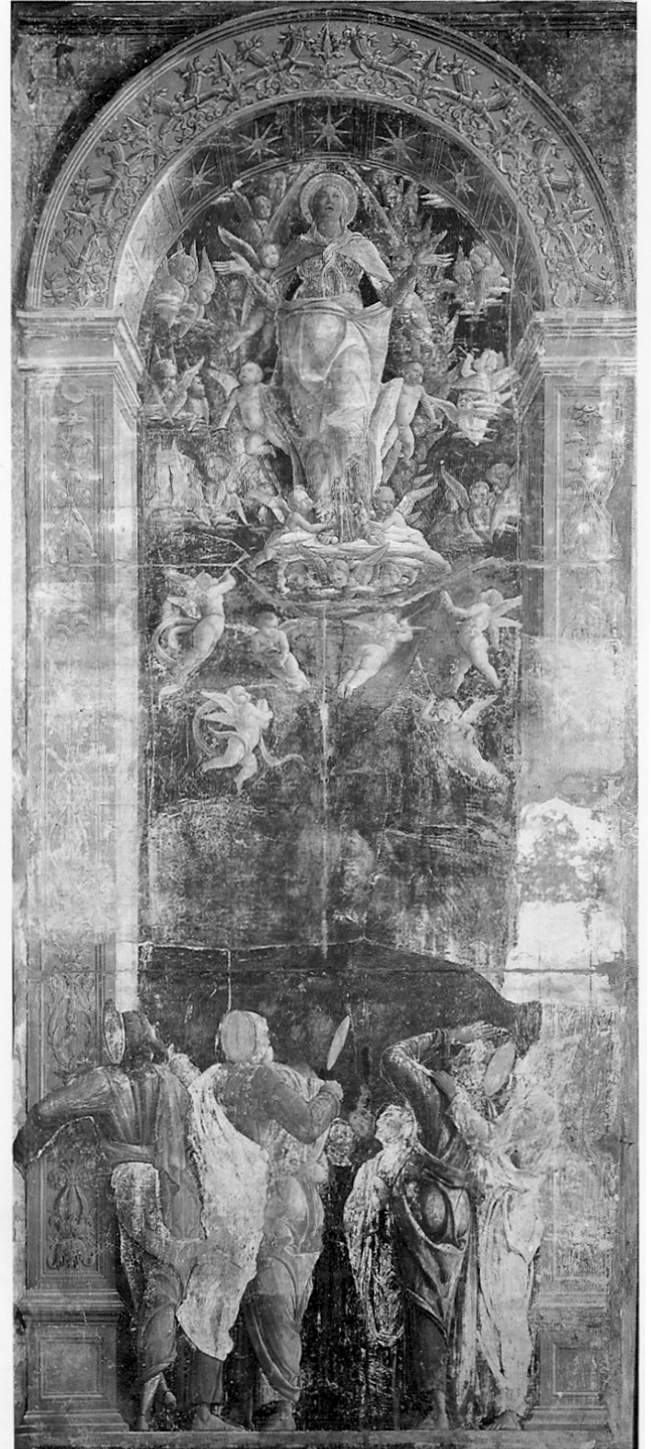

Fig. 47 Mantegna: *Assumption* (1449-55), Overtari Chapel, Chiesa degli Eremitani, Padua.

This has a centric point placed approximately at eye level,¹¹ at a height just below the platform on which the saints stand. 'Our' space is infringed by the arm of the apostle, who embraces the column on the left; the frame is thus integrated into both the work's inner and outer reality. Like the earthbound saints, we gaze up at the vision of the Virgin, who seemingly floats towards our space as she ascends towards heaven, while occupying a space behind the painted architectural frame. Unlike *Trinity*, here we can verify the exact location of the second 'vanishing point', as it is indicated by the orthogonals of the column capitals, which conspicuously contradict those of the column bases. It is also playfully



Fig. 48 Piero della Francesca: *Resurrection* (c. 1460), Museo Civico, Sansepolcro.

indicated by the two diagonally placed putti. Mary occupies a space that is impossible to locate in depth, consistent with her role as an intermediary between heaven and earth.¹² In a sense, the last vestiges of cloud on which she stands, and the cherubim that frame her (forming a mandorla), are now partially, if not entirely, redundant as signs. While their role is certainly not superseded, it is allied to a spatial metaphor unimaginable without the discovery of a consistent perspective.

In Piero della Francesca's Sansepolcro *Resurrection* (fig. 48), the centric point indicated by the work's frame is about a foot below the sloping ground on which the soldiers sleep, and a foot or so above the viewer's eye level.¹³ The life-sized soldiers, asleep on sloping ground, conform to this viewpoint, painted with great care as if from below. But as in Masaccio's *Trinity*, White notes how Christ, here in his Resurrection, is depicted frontally

– ‘there is no foreshortening in the body or the head of the figure of Christ’ (1972, p. 196). White observes that ‘the viewpoint is laid aside as unimportant by the very artist who, for the first time, produced a thorough-going exposition of the constructional problems involved in the rigid application of the laws of artificial perspective’ (p. 196). Yet I would argue that this is not a case of a diminishing of the importance of viewpoint; on the contrary, the registering of a deliberate break in mathematical perspective is entirely consistent with the idea of establishing a necessary distance within such an implied continuity. Field is surely right to suggest that ‘on the theological level one can no doubt make a good case for taking Christ, risen from the dead, as belonging to an order of reality different from that of the everyday world inhabited by the soldiers and by the spectator’; however, I cannot agree with Field that this represents ‘a rather literal-minded interpretation’ of such a theological truth (2005, pp. 227-228). On the contrary, the subtle effect is not at all immediately apparent. The impact is most noticeably felt in the fact that while Christ’s eyes meet ours, they somehow pass through us. He again occupies a different realm, a gap in ordinary spatial experience.

The *Resurrection* thus divides into two clear zones, that of Christ and that of the sleeping guards. The background landscape symbolically registers the miraculous event by depicting the trees to the left-hand side without leaves, and the trees to the right-hand side in full leaf. Spatial and symbolic means for registering the miraculous thus combine; the means by which they impact upon the viewer, however, fundamentally differs. While the former requires our imaginative engagement, the latter is ‘read’ as sign.

7.

If the notion of a secondary viewpoint is thus taken up by a number of Italian Renaissance works, perhaps not coincidentally by artists that might be said to have had *a particular interest in perspectival construction*, then it is also adapted (in a typically innovative way) by a Northern artist known for his exploitation of perspective distortion.¹⁴ In *The Dead Christ in the Tomb* (fig. 49), Basel, Hans Holbein paints a life-sized Christ so realistically dead that

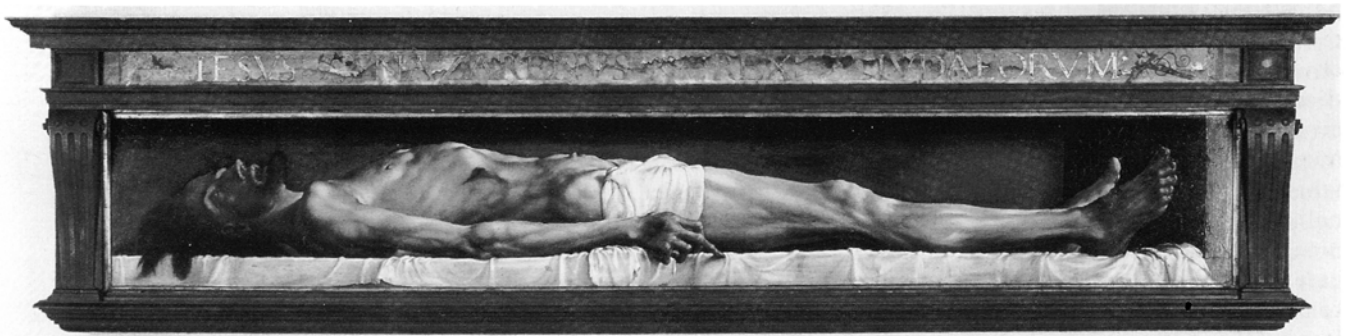

Fig. 49 Hans Holbein: *The Dead Christ in the Tomb* (1521-22), Öffentliche Kunstsammlung, Basel.



Fig. 50 Mantegna: *Dead Christ* (c. 1480-1500), Pinacoteca di Brera, Milan.

it is difficult to reconcile the emaciated corpse with Christ's imminent Resurrection.¹⁵ Julia Kristeva notes that:

The martyr's face bears the expression of a hopeless grief; the empty stare, the sharp-lined profile, the dull blue-green complexion are those of a man who is truly dead, of Christ forsaken by the Father ('My God, my God, why have you deserted me?') and without the promise of Resurrection. (1989, p. 110)

In contrast to works considered thus far, this is a body starkly presented to the viewer, as if in a morgue. Unlike Mantegna's equally poignant *Dead Christ* (fig. 50), in the Pinacoteca, Milan, the figure is decidedly alone.¹⁶ Kristeva argues that 'it is perhaps that isolation – *an act of composition* – that endows the painting with its major melancholy burden' (p. 112). Certainly, the extraordinary elongated proportions of the work increase the foreboding: 'The tombstone weighs down on the upper portion of the painting, which is merely twelve inches high, and intensifies the feeling of permanent death: this corpse shall never rise again' (Kristeva 1989, p. 110).

A number of observers have noted that the body appears at its most fully three-dimensional when viewed obliquely from the left, and from slightly below.¹⁷ The oblique viewpoint reveals the corporeality of Christ, and brings the 'illusionistic' qualities of the painting to the fore. From such a position, the unrelenting realism is so astounding that

one might readily imagine that this *is* the dead body of Christ, *humanitas Christi*, strongly lit from a low source of light from the right, the placement of the bent-back head creating dramatic (and 'terrible') highlights and shadows. Palpably present in human form, we nevertheless cannot reach out to touch the dead Christ from this marginalized vantage point; we are thus separated from the body, which is inaccessible despite its very realism and suggestion of immediate presence.¹⁸

Yet I believe the painting is also meant to be seen frontally, consistent with the vanishing point, the placement of which (as far as I am aware) seems to have received no critical attention. Given the lack of orthogonals, the clues for fixing this position are scant, but are not insignificant: they include the very marks by which Holbein signals his presence as witness, the initials HH and the date MDXXII, painted as though incised into the side of the tomb. That this point of origin is not accidental is indicated by the fact that Christ points directly at it with His extended middle finger, which extends into 'our' space. (This position is consistent with the folds of the cloth on which Christ is placed.) Even more strongly than with Masaccio's *Trinity*, we are reminded by the pointing finger for whom the sacrifice was made. But here, consistent with its Protestant context, there is no intermediary in the figure of the Virgin. As Kristeva notes:

Christ's dereliction is here at its worst: forsaken by the Father, he is apart from all of us. Unless Holbein, whose mind, pungent as it was, does not appear to have lead him across the threshold of atheism, wanted to include us, humans, foreigners, spectators that we are, forthrightly in this crucial moment of Christ's life. With no intermediary, suggestion, or indoctrination, whether pictorial or theological, other than our ability to imagine death, we are led to collapse in the horror of the caesura constituted by death or to dream of an invisible beyond. (p. 113)

And yet it is our ability to imagine death that is key to the notion of identifying with Christ's suffering. Kristeva persuasively argues that the beholder is led to *identify* with Christ in human form:

On the basis of that identification, one that is admittedly too anthropological and psychological from the point of view of a strict theology, man is nevertheless provided with a powerful symbolic device that allows him to experience death and resurrection even in his physical body, thanks to the strength of imaginary identification - and of its actual effects - with the absolute Subject (Christ). (p. 134)¹⁹

I shall return to the issue of identification in the final chapter. If, in an unprecedented way, we are here asked to identify with the reality of Christ's suffering, then the picture also offers some hope of redemption. The left-hand side return of the niche is curiously absent, which again is surprisingly unremarked upon. While this is perhaps consistent with the notion of an oblique viewpoint (from where the return of the niche would not be seen),²⁰ the missing return to the recess shatters the implication of the tomb as a continuation of the viewer's space; and it does so in a very deliberate way. Seen straight on, from a position



Fig. 51 Piero della Francesca: *The Dream of Constantine, The Story of the True Cross* (1452-66), San Francesco, Arezzo.

slightly to the right of the centre of the niche, consistent with the vanishing point, the spatial cohesion of the tomb untangles and we are left with a sense of Christ released from our mathematical space and the ravages of time played out upon his body. The apparent depth of the tomb of the right-hand side of the painting is contradicted by the compression of space of the left-hand side: unlike the insistent three-dimensionality of the oblique view, as the rear wall of the niche aligns itself to the painted surface, Christ inches forward from his confining tomb.

8.

The examples developed thus far in this chapter address works implying the presence of an external spectator, and are very much dependent for their effect on the *physical* presence of such a beholder. But are there equivalent perspectival strategies for representing the



Fig. 52 Giovanni Bellini: *Madonna of the Meadow* (c. 1500-05), National Gallery, London.

supernatural or unconscious for works implying no such spectator, or where the viewer is internal to the fictional world? Here there is no spatial continuity with the external spectator. Rather, if a spectator *is* implied, then we are invited, as it were, to step into the virtual space of the painting. Consequently, any spatial displacement must therefore be internal to this fictional realm, and does not impact upon the real space the viewer occupies. Other means are required to suggest coexistent realms.

One strategy that emerges is to convert part of a work into the content of a dream. Piero della Francesca's *Dream of Constantine* (fig. 51), from *The Story of the True Cross* in San Francesco, Arezzo, does just this. The folds of the tent have been pulled back to reveal the sleeping Constantine, while the guards are oblivious to both the angel, who dramatically enters into the pictorial space, and the dream light emanating from the cross he holds. While our presence is not implied, we are given privileged access to the content of the dream. Wollheim has similarly argued that with certain works the painting - 'or, perhaps better, some part of the painting' - might be converted into the content of a reverie (1987, p. 336).²¹ He uses the example of certain of Bellini's *Madonna and Child* paintings (fig. 52), where the landscape is 'experienced as the content of a shared reverie' between mother and infant (p. 336). Unmentioned by Wollheim, I would contend that the *Dream of Constantine* is an unambiguous example of what he refers to as 'an attenuated version of the spectator in the picture', attenuated because he is represented in the picture, and 'only some part of the picture can be thought of as corresponding to his vision' (p. 336).

Another strategy is to associate a section of the work with the materialization of



Fig. 53 Piero della Francesca: *Madonna di Senigallia* (c. 1478-80), Galleria Nazionale delle Marche, Urbino.

attributes of a figure within the scene. In Piero's small panel from Urbino, the *Madonna di Senigallia* (fig. 53), a doorway leads to an empty room beyond, the room itself becoming an 'other-worldly' attribute of the angel framed by the opening. The beautifully rendered shaft of light illuminates dust in the room, materializing into a 'natural' halo. Neither the Madonna, with downcast eyes, nor the Christ Child, who looks beyond us, return our gaze: only the left-hand angel directly acknowledges us, as though we have perhaps entered the fictional space, and, if not a direct participant, are witness to this miraculous visitation.

A similar identification of figure and space distinguishes some of Fra Angelico Annunciations. In Fra Angelico's Cortona *Annunciation* (fig. 54), an open doorway frames Gabriel's halo, the red curtain surrounding the bed ingeniously mimicking and extending his wings. As with the *Madonna di Senigallia*, the room beyond, with its highly reflective floor, becomes a materialization of the mystical presence of the angel.



Fig. 54 Fra Angelico: *Annunciation* (c. 1430-31), Museo Diocesano, Cortona.

Combining both strategies, Vermeer's early painting *Girl Asleep* (fig. 55), in the Metropolitan Museum of Art, invites us to project the contents of a shared reverie onto an empty room. The painting thus utilizes a *doorsien*, a secondary picture-within-a-picture, which Martha Hollander describes as a narrative or rhetorical device, primarily in relation to Dutch genre painting. Interestingly, and consistent with my argument, Hollander also traces the use of a *doorsien* back to the earlier model of the representation of different realms in relation to the miraculous. She argues that:

In the late fourteenth century conventions were devised for representing two levels of reality: supernatural beings would appear in clouds or circles of light to distinguish them from mortals, or 'speech bubbles' would isolate special utterances from their speakers. Such devices violate the rules of omitting what is invisible and are at odds with the unifying force of one-point perspective. (2002, p. 23)

While there are a number of ways to construct such a *doorsien*, Vermeer utilizes a *doorkijkje* - the Dutch term for a perspectival view through a doorway or opening into a neighbouring space.²² Such devices are recurrent features of Dutch genre painting, although the psychological aspects are typically allied to a work's narrative or rhetorical content. Georgina Cole has argued that 'doors constitute the representational limits of the



Fig. 55 Johannes Vermeer: *Girl Asleep* (c. 1657), Metropolitan Museum of Art, New York.

interior, and consequently function in these works as the architectural medium through which domestic space is constructed and interpreted' (2006, p. 18). One might think of the tension between the pull of the outside and that of domestic security and nurturing in one of Peter de Hooch's genre paintings, where perspective, combined with the use of open doorways, orchestrates the painting into coexistent (and often gendered) social spaces, public and private life.

It is useful to compare *Girl Asleep* with Nicolaes Maes's *The Idle Servant* (fig. 56), both painted around 1657 and both depicting women asleep. The catalogue of the 1696 auction of twenty-one Vermeer paintings describes the former as: 'A drunken sleeping maid at a table' (Blankert 1981, p. 22). The moralising tone is obvious, drunkenness being contrasted with temperance and moderation. And indeed, in *The Idle Servant* Maes goes to considerable lengths to ensure that we 'read' the painting's moral message. The woman asleep is obviously a maid, and the consequences of her 'idleness' are clearly depicted



Fig. 56 Nicolaes Maes: *The Idle Servant* (c. 1657), National Gallery, London.

Fig. 57 Johannes Vermeer: *Girl Asleep* (X-ray detail), The Metropolitan Museum of Art, New York (Snow 1994, p. 187).

- from the chaos of cooking utensils on the floor, to the cat caught in the act of stealing the dinner. The didactic intent is reinforced by the housewife, whose smile and gesture presents her idle maidservant to the audience. And the theatrical term is here appropriate, for while the curtain of Maes's London *The Eavesdropper* (fig. 1) is no longer present, it is to the external viewer that is here addressed.

Both scenes employ a *doorkijkje*, but to very different ends. Maes uses this device to reinforce the painting's narrative content, while Vermeer gives it an enhanced psychological dimension. Unlike Maes's work, the implied presence is internal, not external, to the fictive world. The table and chair establish the spectator in the picture's implied distance from the sleeping woman. Behind her, a half opened door offers us a glimpse into a lobby with a mysterious room beyond. In Maes's *Idle Servant*, the open door establishes the respective realms of servant and housewife. In the Vermeer, the open door sets up a 'charged' threshold where 'whatever haunts the girl asleep also haunts us as well' (Snow 1994, p. 58).

This was not always the case, for the room beyond was not always ruled by absence.



Fig. 58 Pieter de Hooch: *Woman Lacing her Bodice beside a Cradle* (1661-63), Gemäldegalerie, Berlin.

X-rays indicate it was once inhabited by a man wearing a hat, watched by a dog standing in the partially opened doorway (fig. 57), in much the way that the dog functions as a transitional device in de Hooch's *Woman Lacing her Bodice* (fig. 58). In this earlier version of Vermeer's painting, the dog marks the transition between (and connects) the two different realms. It plays a transitional and anecdotal role in connecting the interior and exterior realms of the woman and man.²³ That this variation of the painting hinted at a sexual theme is indicated by its similarity in content to de Hooch's numerous 'merry company' themes.²⁴

Both the shadowy male presence and the *doorkijkje* suggest an erotic reading. Other clues are offered, such as the cropped painting hanging over the woman, which has been identified as Cupid unmasked. But Vermeer removes both man and dog, in an act which I am convinced is of great significance for the future direction of his work. Without their physical presence, other readings are possible. The room beyond can now 'be read as an extension of the girl's reverie, a metaphor for her half-openness, or the destination toward which our own projected viewing tends' (Snow 1994, p. 58). We are given access to the subconscious world of the sleeper. As Gowing writes:

Sleep is revealed as the dropping of a mask, uncovering the fantasy which is the sleeper's secret, a fantasy, we may guess, of love. (1997, p. 51)

While the painting depicts an unconscious rather than supernatural phenomenon, it incorporates a similar gap in ordinary perception. Here *sublimation* becomes integral to the work. Pictorial space is no longer primarily a narrative space, but a destination for the sublimated desires of its inhabitant, and of the beholder. And as Snow adds:

[T]he feeling is equally strong that the girl and her reverie exist to materialize that threshold, and that it addresses the viewer's desire at a more primordial level than she does. And the composition as a whole leaves deliberately unresolved whether the door is the background of grief or of desire, whether it opens on a renunciation of sexuality or as its promise, its 'beyond'. (1994, p. 61)²⁵

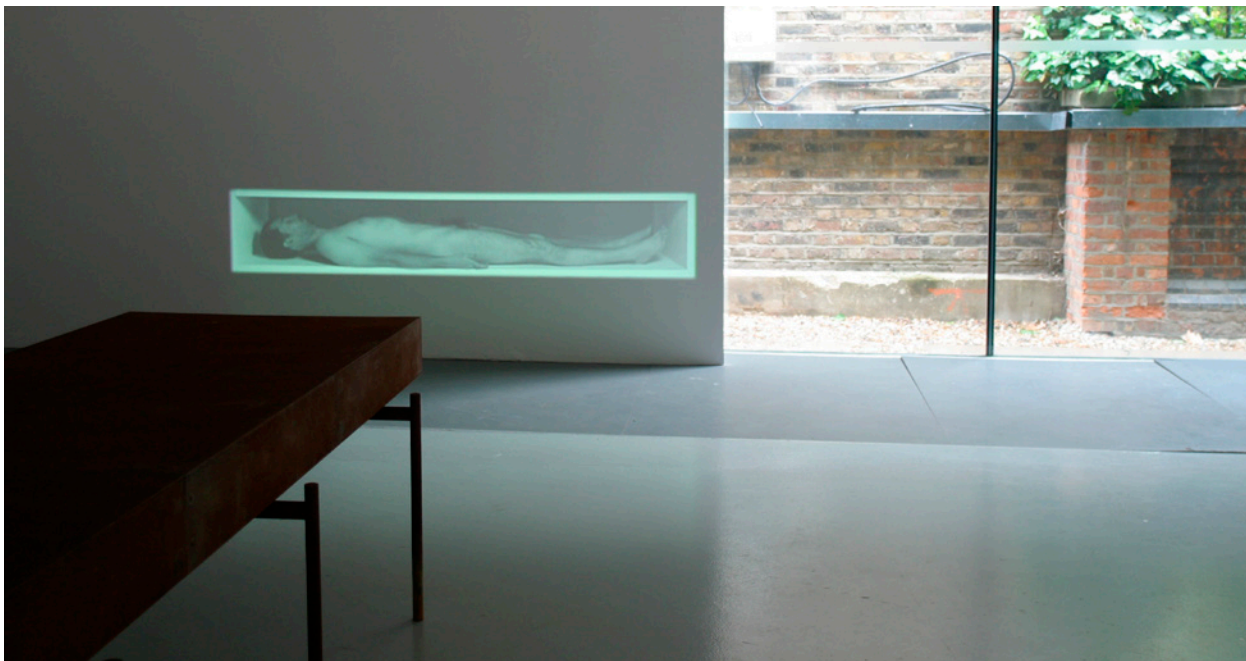

PLENUM #2

2004

Plenum #2 is a site-responsive rather than site-specific piece. It was first shown in Germany, for a solo exhibition at Galerie Sebastianskapelle, a converted chapel which allowed for a view of the piece from a high vantage point. It has subsequently been shown at Chelsea's Triangle Space. *Plenum #2* comprises two elements: a low steel table, 800 x 2400 x 150mm deep, and an elongated projected image. The open-ended metal construction (which conceals a video projector) frames the projection of an empty niche, seemingly recessed into the gallery wall. The materiality of the slab-like table contrasts with the ephemeral nature of the projection, which fades and returns throughout the day as the light changes. Designed for spaces that admit some natural light, this is a projection piece that rejects the notion of the black-box. Periodically, a breathing figure (the artist) slowly materialises within the niche, only to gradually disappear again. The work thus alternates between figural presence and absence. The geometry of the projection, seldom an issue in video art, asserts itself in a very particular way: the viewer can never occupy the point of origin of the projection, which lies immediately above the table; the virtual space of the film, with its pronounced perspectival box, never quite coheres into a fully-formed illusion.

7

On Projection and Sublimation

The pictorial space of great painting repels and envelops us. We may feel trapped and lost in the infinite at the same time. (Ehrenzweig 2000, p. 94)

1.

Many of the works I considered in the previous chapter incorporate what amounts to a distancing or displacement device in order to depict the supernatural or the unconscious. These devices are features of works that otherwise situate a viewer through an imaginative engagement, either as an internal or external spectator. They establish a kind of inviolability, a 'gap' within perception - a space that is implied as being *outside* of normal spatiotemporal relations. I identified three potential strategies for depicting the supernatural or the unconscious within the unified logic of perspectival space. These strategies are not specifically dependent upon (although they might incorporate, or enhance) symbolic elements. However, they do use *indexical* signs as props in an imaginative engagement that determines a work's conditions of access. With works that activate the space of the external beholder, this gap might alternatively be instituted by means of (i) the suggestion of an opening onto an amorphous space that defies delineation, or (ii) a secondary viewpoint contradicting the work's principal vanishing point. The former *selectively* abandons perspectival representation; the latter creates a deliberately 'non-mathematical' placement of a figure (or figure group) within an otherwise 'rationally' constructed pictorial space. By contrast, in works engaging a spectator *in* the picture - whether acknowledged, denied, or where there is a 'felt' absence - a gap is opened up by (iii) the use of a psychologically 'charged' internal threshold onto a discrete space that is metaphorized. With such works, part of the picture is transformed into the content of a shared reverie: an intermediate or transitional space connecting a figure within the work to the beholder.

I have argued that the experiencing of these respective distancing devices is dependent upon a particular kind of pictorial seeing, where seeing-in is supplemented by iconic imagination. An imaginative engagement is necessary precisely because the *affective* aspect of such a 'gap' in perception is dependent not upon the disinterested 'reading' of signs, but the implication of a spatial proximity that is felt, and a continuity that is then broken: a gap that is experienced rather than decoded as a sign. Moreover, this gap is experienced

in a way *that is constitutive of the work's meaning*. *Seeing-with* provides the necessary vivid experience of pictorial space on which such reciprocity depends. It provides an experiential point of view, typical of *centred* iconic mental states. Moreover, with the first two strategies (and arguably, to a lesser extent, the third), *seeing-with* replicates the experience of our bodily situatedness in the real world in that it structures our implied spatial access in a way that draws upon nonconceptual content.

At this point, and for the first time in the thesis, I introduce the notion of artistic expression. What follows is, I must confess, largely speculative, but hopefully not without merit. I want to suggest that such displaced spaces, in their implication of the timelessness characteristic of the unconscious, are receptive to processes that intimate psychological projection, introjection and sublimation; and this, at least in part, explains their powerful emotive affect and metaphorizing potential.

Of course, such emotive potential cannot be isolated from these paintings' predominantly religious content. A requisite set of beliefs and desires forms part of the substantial cognitive stock the suitable spectator must bring to such works. And yet I would argue that these works structure the spatial 'performance' in a way that heightens their affect by an ingenious alignment of *structure to content*: an alignment of subject matter *and* spatial structure. By structure, I refer specifically to the structuring of implied pictorial space relative to the viewer. And to repeat a point made earlier, the concern here is 'with the structure of the "performance" which precedes the effect' (Iser 1978, p. 27).

Without collapsing the differences between the respective strategies outlined above, the argument I propose is that such a displacement device functions as a conduit, or container, for *projective properties*; these are properties of the work of art, but invoke corresponding emotions that colour subsequent perception. This expressive perception intimates a history originating in processes of projection, but also introjection and sublimation - processes particularly apposite for such work's subject matter. It should be stressed that while these projective properties are properties of the artwork, they are not placed there by the artist through any 'concept' of projection.¹ The projective properties of such spaces arise *indirectly*, out of mechanisms for establishing distance within the implied spatial continuity provided by perspective (combined with framing). But in noting the essentially *functional* role such mechanisms play within a perspectival structure that situates a beholder in relation to the fictive space, this is not to argue that artists employing such devices were indifferent or oblivious to their psychological effect. Indeed, as spectators of their own work, this impact would have been noted even if artists lacked the cognitive means to describe such an experience.

2.

Now, as may well be apparent, this is an account that owes much to Wollheim's theory of artistic expression,² but differs from Wollheim's position in a number of important respects. Wollheim supplies a key concept which is central to the notion of how such displacement devices gain emotive content:³ namely *correspondence*, the mechanism by which Wollheim argues a work (or, indeed, a part of nature, such as a landscape) might acquire expressive content. This is a relation between an artefact and an emotion which the artwork is capable of invoking by virtue of how it looks. Wollheim identifies *correspondence* as the mechanism by which an internal psychological state is transferred from the viewer to the work of art, a correspondence between a work and an internal condition dependent upon the 'expressive perception' of *projective properties*. 'Correspondences are formed in projection, and *projection* is a process in which emotions or feelings flow from us to what we perceive' (Wollheim 1987, p. 82).

What is distinctive about projective properties? Wollheim claims that the answer is that 'they are properties that we identify through experiences' that have a 'special complexity':

There are two aspects to this experience which accounts for its complexity. For, on the one hand, though the experience is a perceptual experience, it is not a wholly perceptual experience. It is a partly affective experience, but the affect that attaches to the experience is not affect directed towards the property itself. It is affect directed towards older or more dominant objects. When a fearful object strikes fear into an observer, as it does, it is not fear of that object. On the other hand, the experience reveals or intimates a history. It is not so much that each individual experience intimates narrowly *its own* history: that is true only of the formative experiences in the life-history of the person. What later experiences do is to intimate how the sort of experience they exemplify comes about. Such experiences occur originally in the aftermath of projection, and the fact that later experiences intimate this origin, and do so even when they do not themselves originate this way, is the reason why I call them experiences of 'projective' properties. (1991, p. 56)

As Podro notes, and what is not always fully acknowledged, is that Wollheim thus founds his conception of expressiveness 'upon the internal continuity of mental life', whereby 'early processes of projection affect our later capacity to form relationships with other people and even the way the inanimate world takes on qualities of mood and feeling' (2004, p. 218). These processes evolve into a dispositional pattern; Wollheim claims that 'as the psychology matures, projection becomes more orderly, and those parts of the environment upon which feelings are projected are now selected because of their affinity to those feelings' (1993, p. 152).

Three factors emerge from Wollheim's account, which I briefly summarise. Firstly, expressive perception is a form of *seeing*, one permeated or coloured by an affective experience. Secondly, expressive perception rests upon 'complex' projection, a process

philosophically distinguished from projection in its more rudimentary, 'simple' form (that is projected outwards onto a 'figure' in the environment) in that complex projection describes 'a way of experiencing the external world' (1987, pp. 82-83). As Wollheim notes, 'with complex projection, projection is onto some natural part of the environment, or something which does not, and is not held to, possess a psychology' (1991, p. 58). Unlike simple projection, the property of the environment experienced is not the same as the property projected, 'but something that corresponds to it' (Wollheim 1984, p. 214). It is a form of projection that metaphorizes something without a psychology: if I am touched by melancholy on 'looking out over an estuary and the salt-marshes', or looking at Constable's *Hadleigh Castle*, 'which depicts a landscape with much this character', then 'I respond by judging the scene itself to be melancholy – that is metaphorically melancholy' (p. 215).⁴ Thirdly, Wollheim argues that expressive perception of an artwork does not require someone to be in the immediate throes or aftermath of an act of projection, but that the artwork be perceived as 'being of a piece with' an emotional state felt by the projector (1991, pp. 61-62). Correspondences are 'grounded in trains of association, and it is these associations that function as the background against which correspondence is perceived' (Wollheim 1999, p. 79).

Furthermore, with respect to an artwork rather than a part of nature, it expresses a condition by corresponding to a perceptible property that it has 'intentionally': 'the property is due to the intentions of the artist' (p. 62). Here correspondences are *made*, not *found* (Wollheim 1993, p. 155), and hence are subject to a standard of correctness dependent upon 'the achievement, not just the intention' of the artist (1984, p. 215).

3.

Wollheim's theory has been most effectively challenged by Budd (2001), who is sceptical of the notion of projection grounding expressive perception. Part of Budd's criticism focuses on a supposed weakness exposed by Wollheim's abandonment of the untenable position, seemingly presented in 'The Sheep and the Ceremony' (1993: originally 1979), that expressive perception occurs immediately as a result of 'the projection of the subject's inner emotional state (or, rather, a constellation of such states) onto the object of perception' (Budd 2001, p. 104).⁵ Budd argues that:

In the absence of a compelling argument for the claim that projection of an external item as matching a psychological condition is possible *only because and in virtue of* prior projection, the recognition of projection as an essential constituent of the analysis of expression is entirely dependent upon the intimation thesis. In sum: The rejection of the idea that the activity of projection must take place in or immediately prior to expressive perception, and the failure to eliminate the possibility that the perception of correspondence might be rooted, not just in projection, but in some other, independent psychological phenomenon, requires the introduction of the intimation thesis to bind perception to projection. (p. 105)

Now the problem here for Budd is at least in part one of a lack of supporting arguments, a 'programmatic' charge that Wollheim readily concedes (2001b, p. 255). But Budd also has a more fundamental problem with the affective aspects of Wollheim's account. Budd argues that 'if the affective aspect of the distinctive experience of a projective property is not an actual feeling of the emotion expressed, what is this affective element and how can it fuse with the perception and colour what is seen?' (2001, p. 108)

If many of Budd's criticisms hold, is there anything that can be salvaged from Wollheim's position? I do not attempt to mount a comprehensive defence of Wollheim's theory, nor do I pretend to be in a position to make good its programmatic nature. Indeed, I would concede to Budd that there might very well be other independent psychological phenomena involved in the perception of correspondence, not least given Wollheim's claim that intention 'must be understood so as to include thoughts, beliefs, memories' as well as 'emotions and feelings' (1987, p. 86). But I do not believe we therefore have to entirely abandon Wollheim's theory. We should start by acknowledging, as Podro has argued, that there is a complex interaction between individual projection and a shared culture:

Here we should surely interpolate that once the process of such projection onto the world has become habitual, our world is permeated with such expressive potential. This, surely, is not the product only of our individual projections but of our shared culture; however, we could only participate in this culture if we had ourselves engaged in such projection; we could not simply have learned it up. (2004, p. 219)

Podro argues, after Wollheim, that from an early age we see the world as emotionally coloured through projecting 'such mental states onto external objects', but we also 'carry away with us some memory of those early projections, not necessarily specific projections but at least the generalized sense of making them' (p. 219). But if through this habituation of projection 'phantasy discharges itself into the world' (Wollheim 1984, p. 154), it does so in the context of a shared cultural experience.

Secondly, I would argue that the primary weakness of Wollheim's position is not the intimation thesis as such, but his failure to tie such intimation solely to projection. But granting this, I do not see why Budd assumes that with the intimation thesis the experience of an artwork felt as 'being of a piece with' an emotional state of the perceiver is not a genuine instance of an emotion invoked. As Wollheim argues:

[T]he corresponding emotion, once invoked, should not stand apart from the perception through which it is invoked. It should not be a mere association to what is perceived. The emotion should flood in on the perception. In expressive perception it is not enough that what is perceived invokes the corresponding emotion: the emotion must affect how we perceive what we perceive. Expressed

emotion and perception fuse. (1987, p. 82)

And here I believe arguments taken from Wollheim's *The Thread of Life* (1984) and *On the Emotions* (1999) can help clarify the nature of the affective part of an intimation of not just projection, but a broader set of processes by which phantasy discharges itself.

Crucially, Wollheim claims that emotions are mental dispositions; that this is so 'is something that the vocabulary of emotions can easily obscure', in that 'we use the same words to refer to the emotions themselves and to the mental states in which the emotions manifest themselves' (p. 9). The argument involves the *interaction* (and particularly *causal relation*) between an underlying mental disposition and an occurrent mental state; it requires the distinguishing of occurrent phantasies (as mental states) and dispositional phantasies (pp. 140-142).

Projection, like introjection, is a 'psychic mechanism' (1984, p. 120). An immediate act of complex projection, as a mental activity (p. 34), activates a mental state (p. 33), a physiognomic perception of part of the environment; but it also brings about a mental disposition. As Wollheim notes, 'dispositions have histories' (p. 34).⁶ Expressive perception is a process where dispositions manifest themselves in 'iconic mental states' (p. 120), which perpetrate not the original *act* of projection, but a history whereby a correspondence develops between a part of the environment and feelings which it invokes. Wollheim asks:

What restrictions are placed upon the type or types of mental state in which a disposition may manifest itself? And the answer is that a disposition manifests itself in, and only in, those mental states which typically further, or contribute to furthering, its role. For a mental state to manifest a mental disposition, the type [of] mental state of which it is a token must have a causal efficacy that coincides with the role of the disposition. When causal efficacy and role thus coincide, I shall say that mental state and mental disposition concur. Concurrence is the core of manifestation. (p. 54)

But as I understand Wollheim's complex position, a concurrence is *not*, in itself, the *manifestation* of an affective mental state. For Wollheim, 'manifestation is not concurrence' (p. 54). Rather:

Manifestation is a causal relation, in that a disposition causes, or helps to cause, the mental states that manifest it. But the causality in manifestation follows the lines of concurrence. When a disposition is manifested by a mental state, it causes a mental state that concurs with it, and it causes that mental state because of the concurrence. (p. 54)

In relation to artistic expression, where there is a correspondence between an artwork and a disposition it invokes, the mere perception of this correspondence is not, in itself, an expressive perception. The intimation of a dispositional history *must have causal efficacy*



Fig. 59 Rembrandt: *Self-Portrait* (1661), Kenwood House, Lord Iveagh Bequest, London

with respect to a manifestation of a mental state, where the affect floods in on the perception. Budd is therefore not entirely fair when he claims that Wollheim does not attempt to 'make clear why the perception of correspondence should be made possible only through an affect attached to, integrated into, the perception', and correspondingly 'how exactly the affect manages to transform a perception of something in the environment into one in which the item is seen to correspond to the psychological state the affect exemplifies' (2001, p. 111, n. 13). The correspondence is not a mere association but must have a causal relation to an expressive perception. That a disposition manifests in a mental state is consistent with the role emotions generally play in the mental life of an individual; that the emotion colours the subsequent perception is, I would argue, analogous with Wittgenstein's notion of how a concept permeates perception in the seeing of an aspect, such as when we recognize in the face of an old friend their younger self (2001, 165^e).

Wollheim thus argues that - by and large - 'mental dispositions fulfil their role indirectly' (1984, p. 55). The resulting mental state has psychic force, and hence psychic function, by way of the disposition. So in the case of correspondence, an expressive perception does not have to be immediately preceded by an act of projection; rather, the expressive perception owes its causal efficacy to its phenomenology, a phenomenology that 'expresses that disposition' (p. 56). This is its affective aspect. It expresses a disposition that intimates a history. The causal chain from originating perception to expressive perception passes through a mediating disposition that filters or colours the external perception of the artwork, and expresses the corresponding emotion.⁷ However, this causal chain does not *bind* a dispositional history solely to projection. Other psychic mechanisms might

legitimately seem to play a part. Moreover, Wollheim's account fails to encompass the *reciprocity* we have with artworks, a reciprocity largely provided by the imagination. Spinicci refers to this opening up of figurative space as 'the *space of resonance* of the image', in that it is a 'space that can be crossed *only by virtue of the play of imagination*' (2008). In an expressive engagement with a work such as Rembrandt's *Self-Portrait* (fig. 59), we interpret the externalised physiognomic features of Rembrandt's face in much the same way as we would in an ordinary face-to-face encounter - albeit in a more sustained manner. Moreover, in identifying with Rembrandt's self-reflective encounter with his own image in the mirror, we draw upon our own experiences of encountering our reflected selves. By excluding such encounters from his account of artistic expression, Wollheim cannot claim to have provided a complete theory of artistic expression. Nevertheless, I find it hard to believe that projection, in its origins from earliest childhood, does not, at the very least, play a part in evolving such dispositions, albeit mediated by a shared culture.⁸

4.

If Wollheim imagines this perception of projective properties being applied to the work as a whole, what I have identified in this chapter is rather different and more modest: a discrete space within a work that focuses this 'intimation' of projection, which channels the emotional engagement of the spectator in a way that makes pictorial space a conduit for the psychological engagement with the work. Crucially for my argument, and differentiating it from Wollheim's general account of artistic expression, I claim that with the works I have been considering it is the *matching of structure to content* that heightens such work's latent emotionality. The engagement is psychologically charged through the use of spatial metaphors, realized through a vivid experience of pictorial depth. This, in turn, is dependent upon a work's structuring of the beholder's implied spatial and psychological access made possible by iconic imagination. This imaginative engagement is *centred*, and is both internal to and implicit within the representation. As we have seen, this centred imagining is a feature of specific works implying an internal spectator or where the internal and external spectators fuse.

If we trace the roots of Wollheim's use of projection back to the Kleinian psychoanalysis on which it draws, it is evident that the notion of an *object* or *container* that receives projection has a very real resonance in psychoanalytical theory.⁹ Moreover, this notion of a work that structures its own reception makes it particularly receptive to such intimations of projection, and draws upon what Melanie Klein emphasizes as the structuring role of phantasy (1986, pp. 116-145): a structuring that is somatic in origin. These works structure their own reception in ways analogous to the problematic relationship between self and reality.

Psychoanalytical metaphors for mental space abound. However, the metaphoric

nature of the terminology can be deceptive. W. R. Bion's 'container' (1984) is, as Hanna Segal notes, 'an internal mental space formed by the introjection of a breast capable of containing the infant's projective identifications and giving them meaning' (1991 p. 57). The kind of space I have been discussing, as a container or 'conduit' for projective properties, is *not an internal mental space* (the properties belong to the work of art), although it does invoke an internalisation of part of the artwork. It activates internal states, through the intimation of dispositions that have a causal efficacy. Like Donald Winnicott's 'potential' or 'transitional space' (1951, 1988, 1991), it is to be contrasted with both an inner world and a purely external reality. Winnicott's potential space is a neutral space between mother and child (and later between the individual and the environment), which he conceives of as an intermediate area of experience which 'throughout life is retained in the intense experiencing that belongs to the arts and to religion' (1991, p. 14). It is 'a resting-place for the individual engaged in the perpetual human task of keeping inner and outer reality separate yet interrelated' (p. 2). I believe that the *virtuality* of pictorial art, and particularly of the displaced spaces being discussed, is particularly suitable for problematizing this reciprocal relation between inner and outer reality.

Winnicott's sense of a space where cultural and religious experiences emerge, and where merging and separation coexist, is highly attractive for my argument. But differences also emerge. For Winnicott, the use of the term transitional 'represents the infant's transition from a state of being merged with the mother to a state of being in relation to the mother as something outside and separate' (1991, pp. 14-15). It is not the object or space that is transitional, and - like Bion's container - the term 'space' is again used metaphorically rather than denoting a specifically *spatial* function. Yet it is precisely the intermediary role of pictorial space, when allied to a perspectival construction of different levels of reality (or *unreality*), which is at issue with the displacement devices I have been considering. Such devices draw upon an internal state of a viewer in a way that focuses the psychological experience of the work *as a whole*, through a correspondence between an emotion invoked and projective properties that are not so much perceived as properties of the contained or discrete space, but as properties arising from the implied, yet uncertain, spatial relationship structured between such space and the beholder. These are spaces that cannot be 'entered', even for an implied internal spectator. Such spaces mediate between the supernatural or unconscious content of the artwork and its reception: a reception where the spectator is both internal to the artwork *and* excluded as a presence. Here the experience draws upon a mental disposition in a way which operates at the level of reverie, or various 'visionary' states - states that are, of course, highly appropriate to the work's religious or narrative content. It is the mediating potential of such spaces that focuses our emotional engagement with the artwork. This is dependent upon a *gap* or *displacement* within an otherwise situated relationship, a relationship established either through an implied continuity of real/fictive

space or through the transparency offered by a spectator in the picture.

A Kleinian analysis of the role of religion might help illuminate some of the issues here, because as we have noted these works align structure to content in a very particular way. This structure not only correlates with the theological requirement for distance insisted upon by the religious representation, but with the structural dynamics of Kleinian developmental positions (a correlation that might go some way to explaining such works strong emotive impact upon non-believers). According to S. E. Forster and D. L. Carveth, 'Klein's understanding of phantasy and her emphasis on object relations permit an understanding of God as an internal object' (1999), and it is precisely such an internalisation that these works invoke. Moreover, it is the potential of such spaces to evoke the timelessness characteristic of the unconscious (Freud's primary processes) that is key. That Klein's developmental stages persist throughout life as positions is important, in that religion (and religious imagery) can take on both undifferentiated modes of the paranoid-schizoid position *and* the more mature depressive form that introduces a gap between image and object – *a gap that I would argue is exploited by the 'mature' experience of a religious artwork.*

It is the projective, introjective and sublimatory potential of religion (and, specifically, religious imagery) that is of concern here, particularly in relation to such *displacement* devices. And here we might note distinctions between the various displacement devices so far described. Correggio's ceiling paintings open up onto an undifferentiated and boundless space, a celestial repository for all that is felt to be good. While the spectator is decidedly earthbound, she projects onto and identifies with an all-enveloping transcendental space where inside and outside merge, where boundaries dissolve. These works are thus more obviously consistent with earlier undifferentiated processes of projection and introjection. And yet the works also contain mediating figures - the Virgin in the Cathedral's *Assumption* (fig. 40), and Christ in the *Vision of Saint John* (fig. 41) – introducing a more complex relationship to an internalised object. Indeed, as noted earlier, with the latter work a further mediating figure is reserved for the Benedictines in the choir, where Saint John (fig. 42), their patron saint, is revealed as the original recipient of the vision (Shearman 1992, pp. 181-186). Unlike the direct address from the nave to a lay viewer, here it is Saint John who is the original witness, and the Benedictines see the work through *his* eyes: a spectatorship that 'is more detached, more intellectual, as befits their vocational circumstances and particularly their attention span' (Shearman 1992, p. 184). Here, the timelessness of consciousness is mediated by more mature secondary processes.¹⁰

By contrast to the physical distancing inherent with ceiling paintings, works such as Masaccio's *Trinity*, Mantegna's *Assumption* and Piero's *Resurrection* construct a rational pictorial space where the beholder is brought into what must have seemed in the fifteenth century like an astonishingly intense continuity and proximity with the work's subject.

Nevertheless, strict limits are placed on any suggestion of the beholder's omnipotent control. Firstly, a strict metaphysical distinction is retained between those parts of the pictorial space implied as being in front of or behind the picture surface. Secondly, a gap is opened up through a secondary viewpoint - a displacement that is consistent with the more mature depressive form. To adapt Segal's argument with respect to Freud's views on sublimation, such spaces 'entail the renunciation of the possession of an object', with a resulting 'internalisation' that 'makes the object part of psychic reality' (1991, p. 89).

As Segal notes, it is the depressive position where true symbolism emerges (p. 35), providing an 'experience of separateness, separation and loss' where 'symbolic representation comes into play' (p. 38). Moreover:

It is also in the depressive position only that gradually repression replaces the more primitive defences of splitting, idealization, and projection. The infant becomes more separate and differentiated from his object and capable of feeling guilty about his impulses and phantasies. He therefore represses them. And it is when repression functions that repressed impulses and phantasies can give rise to sublimation. (pp. 28-29).

And following Klein's claim that 'symbolism is the foundation of all sublimation' (1986, p. 97) for Segal, it is the 'symbol proper' that is made available for sublimation (1991, p. 42).

No object of representation is perhaps more poignant in terms of mediating reality than that of the God representation. Here, significantly, we witness the projection of the whole loved object, and an 'identification with the repaired internal object' (Forster and Carveth 1999). Significantly, we are here considering works of reparation that have, as their subject matter, the Trinity, Christ's Resurrection, or the bodily Assumption of Mary. As Forster and Carveth note:

Both the Kleinian and Christian paradigms understand the individual as originally estranged from her primary object. Through a process of reparation or repentance, initiated by a feeling of guilt, she is gradually reconciled to her object. Yet reconciliation is never permanent; it requires a continual renewal of the reparative cycle that brings the subject ever closer to her object. (1999)

This renewal is precisely what these works attempt. In Christianity, the ultimate reparative action is the Incarnation, Christ in human form, who undergoes betrayal and crucifixion, but is ultimately resurrected, rising from the dead. And it is an identification with the repaired object, fully human and yet fully divine, that seems central to the impact of the Trinity, the Resurrection, or Mary's Bodily Assumption (1999). If such works intimate a history of projection and introjection, they also intimate a history of sublimation.

Now of course sublimation is not only a feature of religious works. We have already noted how the empty room beyond in Vermeer's *Girl Asleep* (fig. 55) functions as a sublimatory device, a displacement of the libido that addresses both the woman *and* the

viewer's sublimated desire. Such spaces suggest a reciprocity between a figure in the work and the beholder through a shared reverie. One might also note that the space of the mirror in Vermeer's *The Music Lesson* (fig. 3) plays much the same role.

In *Form in Art* (1955) Adrian Stokes contrasts artworks which draw on the enveloping experience of 'oneness' characteristic of early undifferentiated states with those that draw on the more mature experience of 'otherness' associated with the 'depressive' stage. Stokes's notion is developed by Anton Ehrenzweig (2000) into the suggestion of a work which both envelops *and* repulses. Ehrenzweig argues:

Pictorial space and musical space have the same capacity for compression and simultaneous expansion, stability within constant change, envelopment and repulsion. The pictorial space of great painting repels and envelops us. We may feel trapped and lost in the infinite at the same time. (p. 94)

While I have reservations about the generality of Ehrenzweig's notion of an artwork as a 'receiving "womb"' (p. 104), the idea of 'an inner space that both contains and repels the spectator' (p. 94) seems to me a defining feature of the displacement devices I have been considering. The fact that the subject of such works is so often that of death and bodily resurrection is clearly not coincidental; Ehrenzweig claims that 'death and rebirth' mirrors themes of 'trapping and liberation', a rhythm that 'can be seen as an interaction between basic life and death instincts active within the creative ego' (pp. 176-177).

Is this a fanciful and anachronous projection of twentieth century psychoanalytical notions onto the early Renaissance? There is certainly a danger of overstating the case. Nevertheless, such reparative material accurately mirrors concerns central to Caroline Walker Bynum's *Fragmentation and Redemption* (1992), a compellingly argued book that investigates bodies, and particularly 'the relationship of part to whole' (p. 13), in the late Middle Ages. As Bynum demonstrates, the medieval discussion of bodily resurrection was dominated by issues of 'bodily continuity (of how identity lasts through corruption and reassemblage)' (p. 254). It is perhaps not so fanciful to consider the space opened up by works such as Mantegna's *Assumption* (fig. 48) as representative of a space where the scattered and fragmented body might be made whole again; after all, as Bynum notes, it is the 'whole' body that is the 'mediator between earth and heaven' (p. 13). She writes:

[F]rom the ninth to the sixteenth centuries, the resurrection of the dead was also depicted explicitly as the triumph of whole over part: the gathering together of bones, the reclothing of skeletons, the restoring of exactly those bits of matter scattered at death to the four winds. (p. 184)

The significance of the reintegration of the whole body, in terms of both identity and eternal bliss, is pivotal to Mary's Bodily Assumption and her intercessory role. Indeed, as

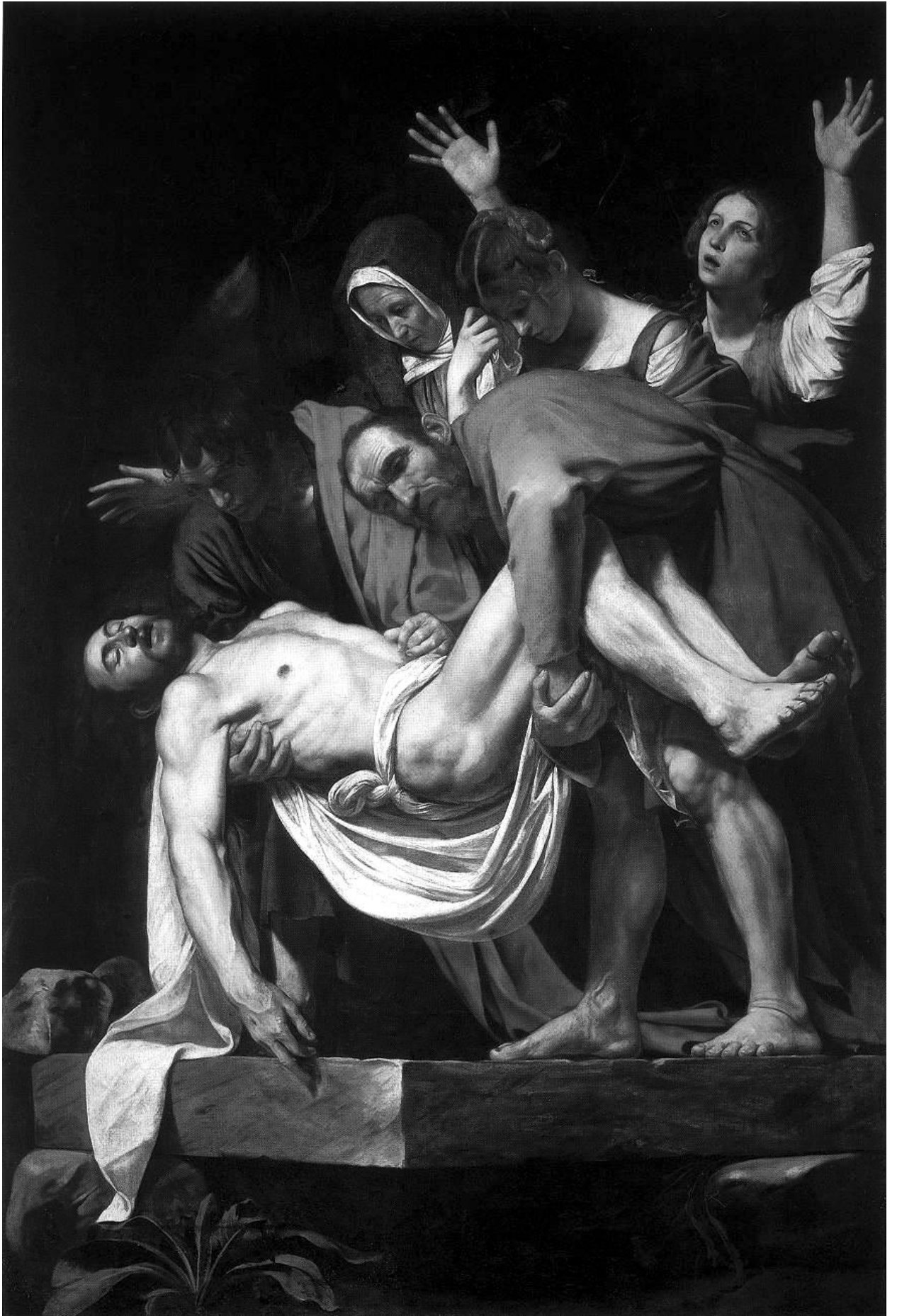

Fig. 60 Caravaggio: *The Entombment* (c. 1602-04), Pinacoteca Vaticana, Rome.

Bynum notes, the concern here 'to bridge the gap between material and spiritual' is not surprising given 'a religion whose central tenet was the incarnation – the enfleshing – of its God' (p. 223). Equally, it is perhaps not surprising that religious artworks metaphorize deeply ingrained psychic processes.

5.

To conclude the chapter, I briefly refer to a religious artwork by Caravaggio. Unlike works considered earlier,¹¹ this work does not maintain the necessary distance normally demanded of religious works, but nonetheless matches content to structure. This work constitutes an alternative way of activating the spectator's space that while 'illusionistic' is certainly not trivial. As Puttfarken has shown, Caravaggio's strategy of reducing his 'pictorial world' to darkness, where the bounding frame is lost, 'acts as a foil against which the figures ... are picked out by a realistically inexplicable bright light' (2000, p. 149). While figuring a presence, this threatens to disrupt religious decorum, precisely because (as is the case with an internal spectator) the imaginative engagement renders the surface transparent; the disquiet this caused at the time is well documented by Puttfarken (pp. 148-150). However, he notes of Caravaggio's *The Entombment* (fig. 60):

[T]he position of the man carrying [Christ's] feet, in particular his gaze downward and out of the picture, leave us in no doubt as to where they intend to deposit Him: they are about to lower Him out of the picture and on to the altar. Here Caravaggio's radical use of *rilievo* and life-size scale to relate his figures to the real world of the viewer is sustained and justified by Christian dogma: the altar represents the tomb of Christ on which the priest during mass prepares the Host, i.e. the bread and wine that are transformed into (or represent, depending on the denomination) the body and blood of Christ. (p. 152)

This counter-example is useful for my argument precisely because of Puttfarken's observation that the structuring of an implied continuity is, in the context of the Eucharist, consistent with religious dogma. Moreover, in terms of a Kleinian understanding of religious practice, this also correlates – quite literally – with earlier stages of introjection, an incorporative phantasy of taking another's body through the mouth which Freud refers to as 'psychic cannibalism'.

In psychoanalytical terms, the Eucharist is the internalisation of the good object that is Christ. And it was seen as such in the Middle Ages, particularly in terms of women mystics. As Bynum notes:

To thirteenth-century women, the mass and the reception or adoration of the eucharist were closely connected with union or ecstasy, which was frequently accompanied by paramystical phenomena. To some extent, reception of Christ's body and blood was a substitute for ecstasy – a union that anyone, properly prepared by confession or contrition, could achieve. To receive was to become

Christ - by eating, by devouring and being devoured. (1991, p. 126)

But as Bynum goes on to note:

The eucharist was, however, more than an occasion for ecstasy. It was also a moment of encounter with that *humanitas Christi* which was such a prominent theme of women's spirituality. For thirteenth-century women this humanity was, above all, Christ's physicality, his corporality, his being-in-the-body-ness; Christ's humanity was Christ's body and blood. (p. 129)

For the medieval believer, the Eucharist *is* Christ - 'one *becomes* Christ's crucified body in *eating* Christ's crucified body' (p. 146). And it is the persistence into the seventeenth-century of such a visceral identification with Christ's humanity that Caravaggio's painting represents to such startling effect, a representation (like Holbein's *Dead Christ*) that is *prior* to the resurrected but separated and distanced Christ. *No distancing device is here required*, in that Christ is here presented as *humanitas Christi*. As Puttfarcken notes, 'Caravaggio's composition could thus be seen as re-enforcing the reality of the Host: as the priest raises the Host during Mass, the figures above the altar would be seen as offering him the body of Christ' (2000, p. 152). It is an image of introjection rather than the sublimation typical of works utilizing displacement devices in the representation of the supernatural. And its spatial structure directly mirrors this distinction.

Conclusion

1.

In this thesis, I have put forward a theory of the role imagination plays in an 'expanded' account of the representational seeing of painting. Ancillary to an experienced resemblance, I have argued that *seeing-with* describes a particular *use* of paintings. We see according to the work, in a way that registers our presence, *or* absence, as an implied beholder. This use of the artwork *as prop* is dependent upon the viewer's sanction. As such, what I have proposed is not an account of depiction itself; rather it describes a supplementary engagement, subject to the will, which is particular to a limited, though not insignificant, range of works. I argue that with perspectival painting, the intense experience of pictorial space that is provided by imagination structures an implied spatial and psychological relationship. It structures a work's *conditions of access*: an implied spatial relation that includes the space *between* viewer and artwork, whether conceived as internal to the virtual world of the painting, or drawing upon the beholder's experience of the real architectural space in which she stands.

While all representational paintings present a point of view, by no means all paintings call for, or, indeed, support such an engagement. Moreover, with many works such an imaginative experience offers little more than an enhanced sense of pictorial depth. These scenes are complete in themselves, requiring no particular thought as to whether the work's depiction point is occupied or not. 'Every image can have a viewer, but this does not mean that the viewer is called upon or challenged to intervene' (Spinicci 2008). But with works implying what Riegl terms an *external coherence*, it is through such an imaginative engagement that our presence (or absence) can be said to contribute to the work's semantic content: to 'complete' the work. Such a *transitive* engagement is made possible by a shared frame of reference between ordinary vision, seeing-in and visualization: a bodily frame of reference that I argue has the potential to draw upon nonconceptual content.

Using relevant art historical examples, I have attempted to demonstrate *how* such an engagement facilitates the complex reciprocity implied by certain paintings, where an

implicit beholder enters into the work's meaning through an encounter structured by the painting and its framing. Spinicci refers to the 'dialogic' nature of such images (2008). But a *dialogic situation* can be conceived as internal or external to the figurative space. Wollheim's spectator *in* the picture overcomes the fundamental split between figurative and objective space through an identification with a beholder internal to the fictional world of the painting. Here the picture surface (in terms, of course, of the *imaginative* engagement) is transparent. But I have also argued that with some works, integrated into their architectural contexts, the problematic relation between figurative and real space is utilized by the artist in a way that reinforces the work's content: here structure is aligned to content so that 'we are invited both to attend to and to imagine away the distinction between real and fictive, the very distinction presupposed in seeing the painting as a representation in the first place' (Podro 1998, p. 16). Part of the virtual world encompasses (and inflects) the real space of the spectator, in a way that the inherent uncertainty about 'where the painting is' is replicated by an equivalent uncertainty about our location in *real* space. And it is this uncertainty, dependent upon the viewer's imaginative consent, that allows us to believe in the very fictional scene which confronts us - a scene where we are brought into a direct encounter with the deity. The conceptual content is not so much 'read', as structures an imaginative (rather than illusory) engagement providing an unprecedented reciprocity, while maintaining a necessary distance befitting of its subject.

2.

Does such an engagement have relevance beyond representational painting? Can it inform the reception of contemporary artworks, such as installations or video installations? More pertinently, can we usefully distinguish between an *implicit* spectator and the *literal* presence such works by definition engage? I do not attempt categorical answers to such questions, or to imply that the experiences are somehow equivalent; rather, I conclude the thesis by raising a number of issues that I hope to engage in future research.

Of course, my own sculptural installations hopefully demonstrate the potential for drawing *some* parallels between the reception of perspectival painting and a contemporary art practice: albeit a practice distinguished by its concern with projective geometry. The works presented in this thesis problematize the relation between the spectator's implied and literal presence in a number of ways, that include: (i) the structuring of contrasting modes of viewing, by juxtaposing spaces that can or cannot be entered; (ii) the duplication, or juxtaposition, of real and projected space, video projection and materially present object; (iii) drawing attention to the perspectival structure of film to intimate implicit viewpoints; (iv) the use of scale, or abrupt shifts in scale, to suggest figural presence *and/or* distance; (v) drawing attention to the screen as both 'tactile' surface and threshold condition; (vi) integrating the work's framing into both its inner and outer reality; (vii) juxtaposing 'real

time' video footage with loops that extend temporality.¹ But are these themes particular to a practice that explicitly alludes to painting? Or are they indicative of wider concerns with respect to a work's reception?

It is with the development of a 'situational' art in the 1960s that the literal presence of a beholder is theorized as both definitive of the new art *and* inherently problematic. The development of so-called Minimalist art² opened up new possibilities for drawing a spectator into experiences that now included the gallery space as spatial container. This was a reaction against the kind of painting championed by Clement Greenberg and Michael Fried. Greenberg writes in his polemical 1965 essay 'Modernist Painting': 'Where the Old Masters created an illusion of space into which one could imagine oneself walking, the illusion created by a Modernist is one into which one can only look, can travel through only with the eye' (1982, p. 8). For Greenberg, this drive towards *opticality* (contrasted with *tactility*) and *flatness* distinguishes painting from sculpture.³ Greenberg and Fried condemned Minimalist artists' blurring of the boundary between painting and sculpture, their inclusion of 'real' objects (such as Flavin's fluorescent lights, or Carl Andre's bricks) and their direct address to an 'audience'. As Claire Bishop notes, 'Minimalism's call to the beholder threatened two of the paradigms that Fried, like many of the critics at the time, held dear: firstly, the autonomy of the art object (in other words, its self-sufficiency and independence from context) and secondly, the purity of each artistic medium' (2005, p. 53).

Now all of this is well-trodden ground. Nonetheless, the point I want to stress is that Fried's 1967 essay 'Art and Objecthood' (1998, pp. 148-172) makes it clear that he considers that the Minimalist Art he characterises as *literalist* 'is not an isolated episode but the expression of a general and persuasive condition' (p. 149) – a condition of *theatricality* that Fried makes direct parallels to in his consideration of eighteenth-century French painting in *Absorption and Theatricality* (1988).⁴ Indeed, it is arguably only with this later work that Fried's designation of emotionally mute Minimalist works as 'theatrical' really makes sense. Committed to the notion of the absorptive art we noted earlier, an art that presents 'the image's absorption in itself' (p. 50), Fried writes disparagingly of the notion that 'someone has merely to enter the room in which a literalist work has been placed to become that beholder, that audience of one – almost as though the work in question has been waiting for him' (1998, p. 163). And of course Fried is right to register this aspect as a defining feature of the new art he so opposed, to the extent that Bishop can claim that 'an insistence on the literal presence of the viewer is arguably the key characteristic of installation art' (2005, p. 6). Fried thus, albeit from a highly critical perspective, anticipates the move to an art practice that privileges the experience of 'a *situation* – one that, virtually by definition, *includes the beholder*' (Fried 1998, p. 153). This challenged modernist sculpture's self-containment by opening up a situation that includes the 'beholder's *body*' (p. 155), and threatened an

autonomy conceived as both spatial and temporal. As Rosalind Krauss notes:

With regard to sculpture, the point on which the distinction between itself and theater turns is, for Fried, the concept of time. It is an extended temporality, a merging of the temporal experience of sculpture with real time, that pushes the plastic arts into the modality of theater. While it is through the concepts of 'presentness and instantaneousness that modernist painting and sculpture defeat theater' [Fried 1998 p. 167]. (Krauss 1981 pp. 203-204)

Fried's championing of an anti-theatrical art returns us to earlier distinctions between internal and external coherence made by Riegl. Unlike Fried's anti-theatrical one-sidedness, Riegl recognizes that a 'mature' external coherence rests not upon an antagonistic relation between the two notions, but upon a fully resolved internal coherence. Moreover, the development of means for a spectator's exclusion is intimately tied to means for her inclusion, an inclusion no longer reliant upon a direct address to the beholder. Riegl had in many ways predicted the subjectivism underlying Fried and Greenberg's positions; even by 1902, Riegl is claiming 'the dominant tendency nowadays is to let the work of art vanish as a physical object and become absorbed into the inner subjective experience of the viewer' (1999, p. 64). As Iversen notes, this fits with his intriguing though questionable 'historical scheme that sees the history of art as a continuous development leading from an extremely "haptic" or objective view of things in the world to an extremely "optic" or subjective conception of things' (1993, p. 10). But if definitions of installation art which focus on the spectator 'completing' the work sound very much like Riegl's characterization of external coherence, then how does the completion of the work differ when the spectator is now a literal rather than the implied presence of painting? As I have attempted to show, even when the external spectator enters a painting's content, this presence is still implicit to the work. By contrast, if the 'completion' of installation art is to be more than a mere tautology, a consequence of an art we necessarily move through, then is there an equivalent *dialogic character* to the reciprocity a transitive engagement implies for painting?

These questions are pertinent, in that much recent writing on installation and/or video installation art fails to define what is meant by the 'participatory' and 'activated' nature of an art that 'immerses' the viewer within 'spectacles' of sight and sound. John Ravenal, for instance, argues:

Many video installations ... draw attention to the viewer as being external to the imagery, thereby raising issues of perception, observation, and spectatorship. Unlike film's stationary audience, viewers of projected video installations are often active participants who move through the surrounding space. The heightened awareness of the conditions of spectatorship often becomes, in some ways, the subject of the work. (Ravenal 2002, p. 2)

And yet the examples that Ravenal employs of practices that make 'the conditions of



Fig. 61 Shirin Neshat: *Rapture* (1999).

spectatorship' a central aspect of the work (Pipilotti Rist's *Sip My Ocean*, Shirin Neshat's *Rapture*, Jane and Louise Wilson's *Stasi City*) are bound by cinematic notions of narrative space. Our external status is counterbalanced by the pull of the fictional realm which Ravenal rightly states is so typical of the cinematic experience; indeed, it is just such a toing and froing between a position of exteriority and the fictional pull resulting from the transparency of the medium which 'heightens' the conditions of spectatorship in such work. Thus, in Neshat's *Rapture* (1999) (fig. 61) the viewer is implicated in a very particular sense: we are caught up in the narrative space between two cinematic projections, a space between the segregated worlds of men and women, where we are acutely aware that *we do not belong*. If this *psychological* interplay between exteriority and cinematic pull did not exist, *Rapture* would be a spatial video practice only in the sense that *any* multiple-screened cinematic experience that immerses the spectator in 'enveloping spectacles of moving sight and sound' (Ravenal 2002, p. 1) becomes, by definition, spatial.

Ravenal acknowledges that 'the viewer's relationship to the performers in *Rapture* ... is somewhat more open-ended' than in early video's use of the 'direct address' (2002, p. 53). Neshat's work is not, as in Vito Acconci's, a 'one-to-one confrontation with the artist': rather, 'the experience of being caught in the crossfire of gazes ... suggests an affinity with works whose primary focus is on space and attention rather than viewer and artist dynamics' (2002, p. 53). Yet the space of representation is dislocated from the space of reception. What is lost is precisely the distinction from cinematic film that Dan Graham makes for early video art:

Video feeds back indigenous data in the immediate, present-time environment. Film is contemplative

and “distanced”; it detaches the viewer from present reality and makes him a spectator. (Cited in Rush 1999, p. 84)

3.

Immersive narrative based video ultimately owes more to cinema than it does the kind of situated relationship I have proposed in this thesis. However, early ‘situational’ practices utilize structuring devices that might legitimately be considered as analogous to those of situated painting. I conclude the thesis by proposing three such devices. The last two are particular to works combining video or film with installation. The first is symptomatic of work that Bishop categorizes as ‘organised around a phenomenological model of the viewing subject’ (2005, p. 10).⁵

As artists began to question the relationship between artwork and the space of the gallery, Merleau-Ponty’s *spatiality of situation* (2001, p. 115) offered a theoretical framework for their practice. If language orientated conceptual artists typically referenced the language-games of Wittgenstein’s *Philosophical Investigations* (2001), Merleau-Ponty offered a way to theorize a situation where ‘our relationship to space is not that of a pure disembodied subject to a distant object but rather that of a being which dwells in space’ (Merleau-Ponty 2005, p. 55). Merleau-Ponty’s influence is explicit in artists’ statements from this period. In a letter to Benjamin H. D. Buchloh, Dan Graham writes of a Sol LeWitt exhibit:

As the viewer moves from point to point about the art object the physical continuity of the walk is translated into illusive self-representing depth: the visual complication of representations ‘develops’ a discrete, non-progressive space and time. There is no distinction between subject and object ... Object and subject are not dialectical oppositions but one self-contained identity: reversible interior and exterior termini. All frames of reference read simultaneously: object/subject. (Cited in Buchloh 2000, p. 384)

If Minimalist sculpture, such as that by Judd, Andre, Flavin, LeWitt and Morris, drew attention to ‘the contingencies of site and the variability of perspective’ (Batchelor 1997), Postminimalist artists, such as Asher, Irwin, Nauman, Nordman and Wheeler, created spaces devoid of all objects, further blurring the boundary between artwork, architectural container and beholder. Here the work’s architectural ‘frame’ is integrated into its inner apparatus, to the extent that it *becomes* the work of art.⁶ Michael Asher describes his intervention at the Pomona College Art Gallery (1970) (fig. 62) in terms thus: ‘The installation shifted formal control from a singular object to a seemingly neutral given architectural structure previously containing that object. The induced and forced neutrality of the object [in Minimalist sculpture] had been dependent upon the false neutrality of the container’ (Asher 1983, p. 38).⁷ Comprising two neutral triangular spaces connected by a narrow passage, this was a work open to the outside, enterable for twenty-four hours

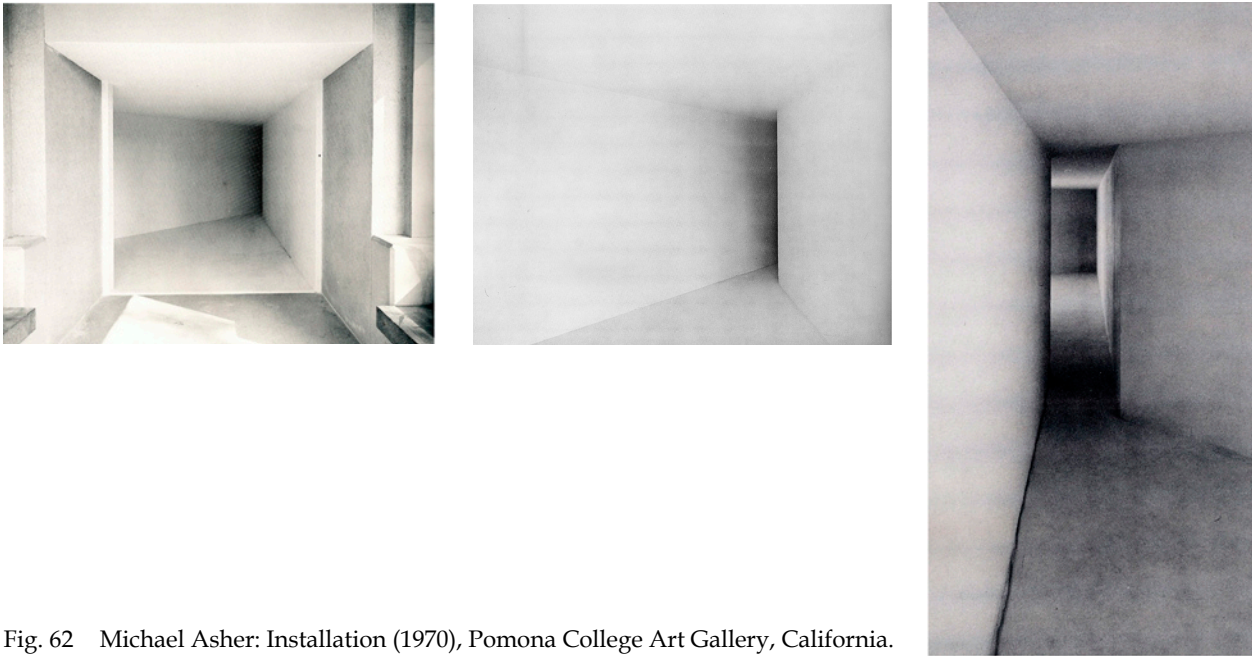

Fig. 62 Michael Asher: Installation (1970), Pomona College Art Gallery, California.

a day: 'exterior light, sound, and air became a permanent part of the exhibition' (Asher 1983, p. 34). While during the day the front triangle was 'saturated' with daylight, the light dispersed unevenly in the unlit second space: 'Entering and moving through the installation, the viewer became increasingly removed from the exterior reality, at the same time perceiving gradual abstractions of the reality within a formally determined and controlled space' (Asher 1983, pp. 38-42).

This manipulation of the juncture between a tightly controlled environment and the contingencies of the outside world juxtaposes different levels of reality, in which the short connecting passage plays a vital role as threshold condition. In the more overtly phenomenologically driven work of James Turrell this mediation of realities directly references the metaphysical divide of painting and beholder. Turrell's *Skyspaces* (fig. 63) are enclosed spaces open to the sky, with steeply slanted edges that conceal any apparent depth to the reveals of the opening. As Turrell notes: 'These pieces deal with the juncture of the interior space and the space outside by bringing the space of the sky down to the plane

Fig. 63 James Turrell: *Skyspace* (2006), Deer Shelter, Yorkshire Sculpture Park, Yorkshire.



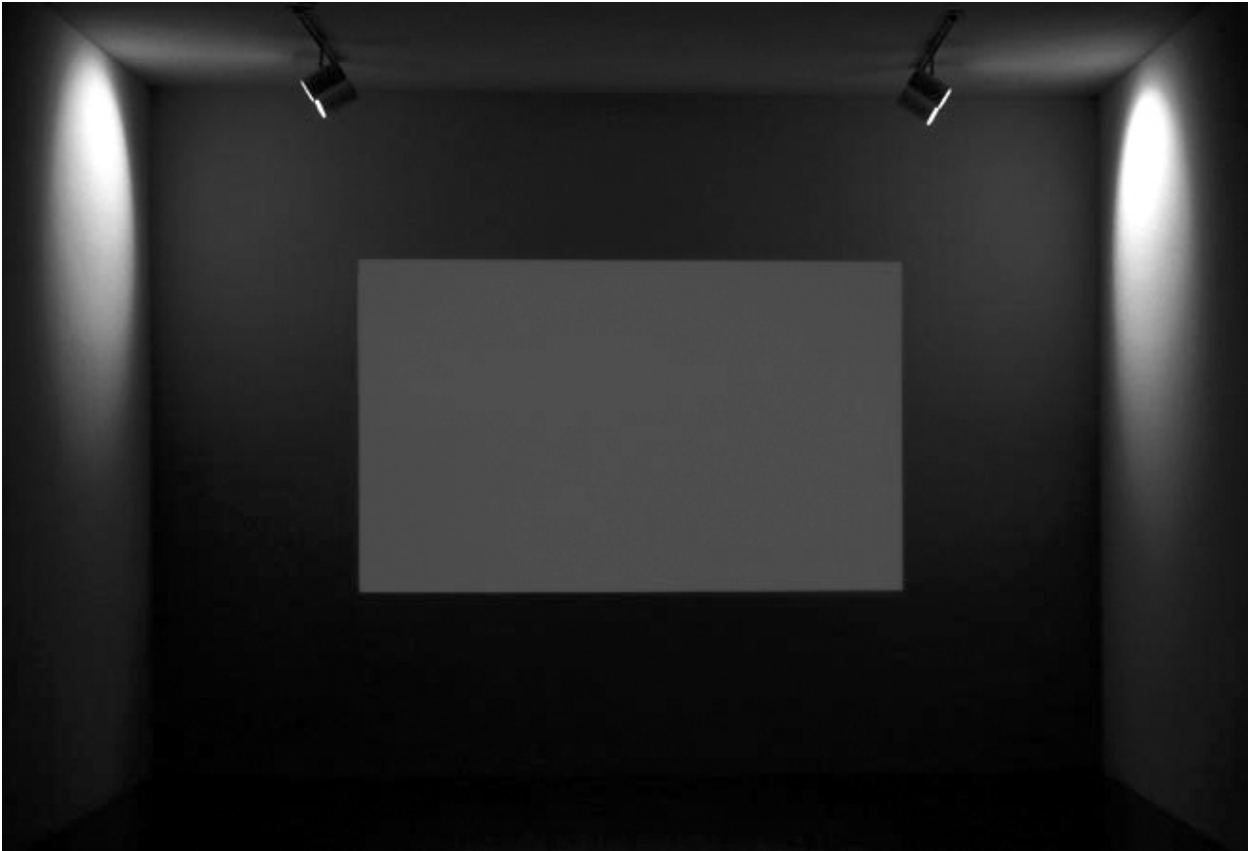

Fig. 64 James Turrell: *Danae* (1983), Mattress Factory, Pittsburgh, Pennsylvania.

of the ceiling ... The sense of closure at the juncture appears to be a glassy film stretched across the opening, with an indefinable space beyond this transparency that changes with sky conditions and sun angles' (2002, p. 96). Again, perception (sight, sound and touch) is heightened in a work conceived *as* a framing device, rather than as an object in space. If Masaccio's *Trinity* utilizes its frame and perspective in order to align structure to content, here the structuring role of the framing container *becomes* the work's content. And if with an imaginative engagement with painting we imagine away the surface, with Turrell we perceive a nonexistent surface.

Other installations by Turrell manipulate reality in a more directly physiological way that confounds our perceptual faculties.⁸ Abstracted from the real world into 'dark spaces', Bishop defines these works as inducing a kind of *mimetic engulfment*, in that such installations '*undermine* the self-reflexivity of phenomenological perception' (2005, p. 85). *Danae* (1983) (fig. 64) and *Trace Elements* (1993) are part of a series of 'space division constructions' that reference painting,⁹ and use the same framing device of the *Skyspaces* to create a vertical rectangular opening without visible sides. An interior space is divided in two, so that 'from a distance, the junction between the two spaces is seen as surface and resembles a rectangle painted on the wall' (Turrell 2002, p. 104). The solidity of this coloured rectangle dissipates as we approach the supporting wall. The far space is lit from concealed lights in such a way that even as the viewer perceives a space beyond the opening, 'the transparent surface holds in its strength, so that even on approach there seems to be a glassy, transparent skin that is looked through' (p. 104). The tangibility of this seemingly physical surface is both



Fig. 65 Dan Flavin: *Untitled (to Jan and Ron Greenberg)* (1972-3), Dia Art Foundation, New York.

beautiful and disquieting.

The physiological impact of these spatial juxtapositions is replicated in some of Flavin's installations from the 1970s, where architectural situations are created for his lighting constructs. These works represent a shift towards works that exploit 'an optical shift and retinal reaction' (Flavin; cited in Govan and Bell 2004, p. 195). Flavin developed a series of 'barrier' works that obstruct the viewer, while allowing a restricted view into a space beyond. In works such as *Untitled (to Jan and Ron Greenberg)* (1972-73) (fig. 65), a narrow gap is left at one end of a back-to-back vertical line of abutted fluorescent lights, green on one side, yellow on the other. The juncture between adjacent spaces again takes on a tangible physical presence.



Fig. 66 Bruce Nauman: *Green Light Corridor* (1970-71), The Solomon R. Guggenheim Foundation (Panza Gift), New York.

While such works by Flavin and Turrell structure a perceptual rather than imaginative engagement, it seems to me that these pieces construct a gap in perception that is comparable to the painting devices discussed in Chapter Six. Not in terms of their structuring of religious or spiritual content; Flavin, in particular, had ‘no time for contemplation, psychology, symbolism, or mystery’ (Flavin; cited in Batchelor 1997, p. 57). But in pushing perception to its limits, these works address metaphysical junctures between spaces that question *where* the work is: and this does seem to invoke a kind of projective identification that draws upon unconscious mechanisms. Indeed, Turrell (unlike Flavin) specifically sets out to ‘address the light that we see in dreams and the spaces that seem to come from those dreams and which are familiar to those who inhabit those places’ (Turrell; cited in Birnbaum 2002, p. 230). As Bishop notes, Turrell ‘structures a subsuming *over-identification* with the void-like coloured space that engulfs and penetrates us’ (2005, p. 87). This identification draws the viewer into the work’s content, in a work that (to refer back to Ehrenzweig) both envelops and repulses (2000, p. 94).



Fig. 67 Bruce Nauman: *Double Wedge Corridor (With Mirror)* (1970-74), The Solomon R. Guggenheim Foundation (Panza Gift), New York.



Fig. 68 Bruce Nauman: *Live/Taped Video Corridor* (1969-70), The Solomon R. Guggenheim Foundation (Panza Gift), New York.

4.

If Turrell's work makes the ambiguity of *where* the artwork is central to its concern, then other Postminimalist work uses mirrors and video/film to draw the viewer into the work's content as an implicit, not just a literal, presence. This is achieved through devices that are frequently combine different levels of reality: the use of video or film loops to overlay time frames, and/or the duplication of space on monitor/screen and the space of reception.¹⁰

Nauman's *Green Light Corridor* (1970-71) (fig. 66) applies Flavin's 'abusive' use of green light to a corridor so narrow that it has to be entered sideways. Nauman's corridor pieces manipulate our perception of reality, but in a confining and controlling environment that in contrast to Turrell's metaphysics sets out to 'jolt' the viewer (Schimmel 2003, p. 69). Nauman describes such corridor pieces thus: 'It's another way of limiting the situation so that someone else can be a performer, but he can do only what I want him to do. I mistrust audience participation. That's why I try to make these works as limiting as possible' (Nauman 2003, p. 113; originally cited in Sharp 1970, p. 23). Here the works are completed in ways where the viewer's participation as 'implicit' spectator is tightly constrained by the sheer physicality of the works. The effect is destabilizing - physiological *and* psychological - without cathartic release.

Nauman's use of mirrors and closed-circuit video introduces a more interactive relationship with the engaged, but decentred viewer. In *Double Wedge Corridor (With Mirror)*



Fig. 69 Dan Graham: *Present Continuous Past(s)* (1974), Centre Georges Pompidou, Paris.

(1970-74) (fig. 67), a mirror, placed somewhat short of the apex of the wedge, suggests a continuity of the narrowing corridor space negated by the height of the mirror and the reflection of another figure entering the other corridor wing. Of the use of video monitors in *Live/Taped Video Corridor* (1969-70) (fig. 68) Nauman states:

When you realized that you were on the screen, being in the corridor was like stepping off a cliff or down into a hole. It was like the bottom step thing – it was really a very strong experience. You knew what happened because you could see all the equipment and what was going on, yet you had the same experience every time you walked in. There was no way to avoid having it. (Nauman 2003, pp. 151-152; originally cited in Sharp 1971, p. 30)

Dan Graham uses mirrors and video to create a more dialogic, reciprocal situation, where the viewer interacts with both themselves and others. Again, Graham blurs the boundaries between implied and external viewers by overlaying different spatiotemporal realms. In *Present Continuous Past(s)* (1974) (fig. 69), a time delay of 8 seconds between a wall-mounted camera and monitor means that a viewer sees herself in the monitor as she appeared 8 seconds earlier, plus a reflection, in the rear mirror, of the monitor recording her a further 8 seconds back in time: a reflective sequence which regresses backwards in time at 8 second intervals. As Graham notes:

When the observer's responses are part of and influencing his or her perception, the difference between intention and actual behavior as seen on the monitor immediately influences the observer's



Fig. 70 Anthony McCall: *Line Describing a Cone* (1973).



Fig. 71 William Raban: *2'45"* (1973).

future intentions and behavior. Two models of time are contrasted in *Present Continuous Past(s)*, the traditional Renaissance perspective static present-time, which is seen, in this work, as the (self) image(s) in the mirror(s), and the time of the video feedback loop. (1993)

One might question Graham's contention that Renaissance perspective presents only static present-time.¹¹ And yet Dan Graham undoubtedly conceptualizes the viewer's position here in a way that problematizes the relation between implied and literal spectatorship by overlaying complex levels of mediated reality.

In Britain, such layering of time and space was inherent to many filmmakers engaged in expanded cinema. Anthony McCall's *Line Describing a Cone* (1973) (fig. 70) is a film that 'exists only in the present: the moment of projection. It refers to nothing beyond this real time. (In contrast, most films allude to past time)' (McCall, 1978, p. 250; cited in Joseph 2005, p. 42). In what he refers to as his 'solid light films', McCall transforms projected light into sculptural form. McCall claims the piece to be 'the first film to exist solely in real, three-dimensional space ... It contains no illusion. It is a primary experience, not secondary: i.e. the space is real, not referential; the time is real, not referential' (McCall, 1978, p. 250; cited in Joseph 2005, p. 42). Yet while the work refers to nothing other than itself, it draws spectators into its content as they interact with the three-dimensional light-form.¹²

If McCall work insists only upon real time and real space, other works of expanded cinema build layers of past time into a work's present reality. The audience is directly implicated by William Raban's *2'45"* (1973) (fig. 71), a film and subsequent projection of a blank screen, the projection (with audience) recorded and repeatedly re-filmed, the overlapping of successive projections drawing successive audience members, and filmmaker, into the work's content. Raban states:

An important aspect of *2'45"* is that it records the history of its making. It is a 'time-lapse' film in the sense that within its 2 minutes 45 seconds duration, it reveals all its past presentations as a film of a film of a film etc.. (2008)

An equivalent overlaying of time and space is intrinsic to Tony Sinden's *Another Aspect/*

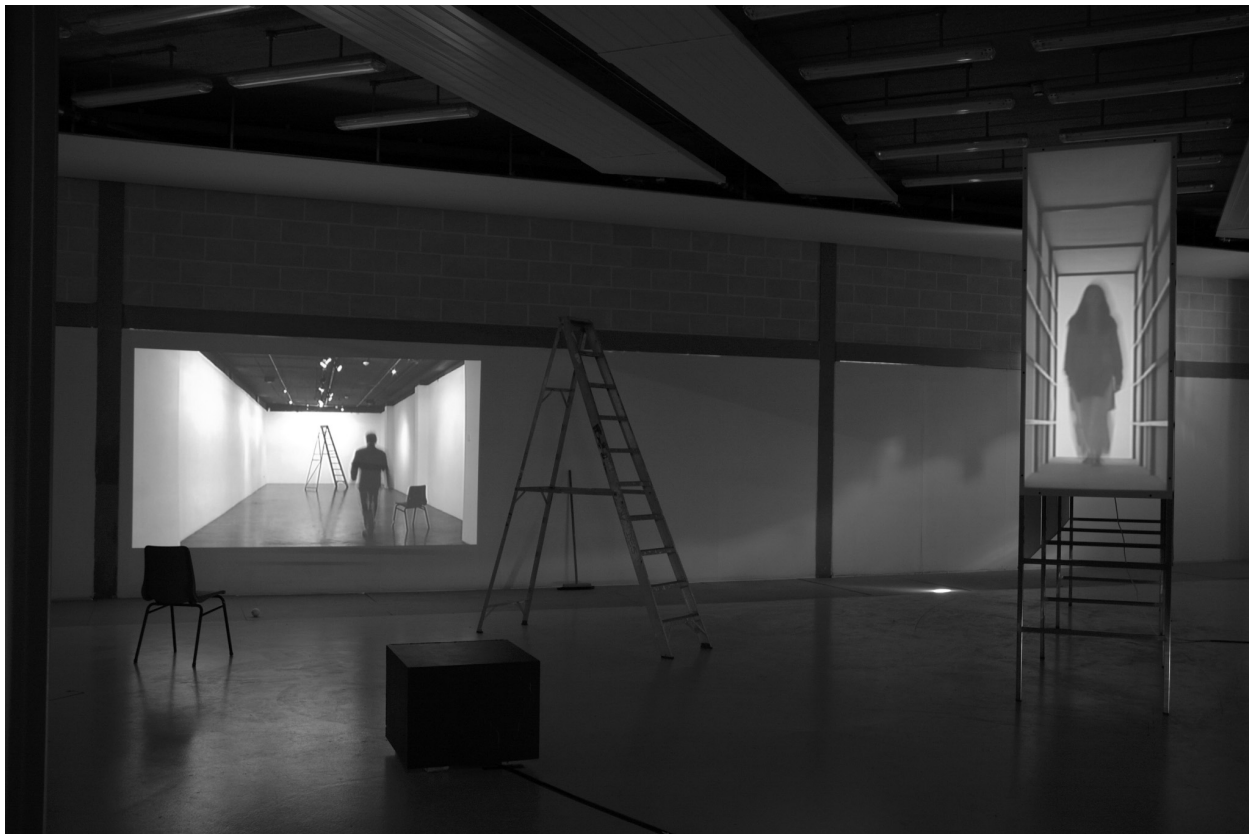

Fig. 72 Tony Sinden: *Cool Room* (2002); Ken Wilder: *Intersection* (2006).

Another Time (1979). A. L. Rees describes how the embodied integration of the spectator into the work is achieved through having the viewer moving through a space which overlays 'real things - a ladder, a chair - plus their shadow reflections or projected images' (2003, pp. 8-9). Sinden's more recent *Cool Room* (2002) similarly duplicates projected and 'real' space, creating a dialogue between objects that Sinden is seen moving in the film, and their counterparts in the real space of the gallery.

Appropriately enough, *Cool Room* was installed adjacent to my own work *Intersection* at the 2006 exhibition *Angles of Projection* at Chelsea College of Art and Design (fig. 72). *Intersection* is a work that likewise overlays video footage of a framed object onto the object itself. This duplication structures different levels of reality. The work references Minimalist sculpture, Postminimalist environments and expanded cinema practices. But it also structures two viewpoints, suspended in space, from which projected reality and physical object coincide. It thus juxtaposes situational concerns that activate the beholder's space with explicit references to perspectival painting: a type of painting that is too often described as necessarily producing a disembodied spectator. I have hoped to prove otherwise in this thesis, and in so doing I have appropriated a rich source of inspiration for a situational art practice that problematizes the threshold between two and three-dimensions. As such, my artwork draws upon a lack of assuredness about the *whereness* of the virtual and of the beholder's positioning relative to the virtual, drawing this uncertainty into the work's content.

Notes

Preface

- 1 I am very grateful for the interest shown by Professor Spinicci in my work, following the publication of my paper 'The Case for the External Spectator' (2008). It emerges that we share a very similar position on the role that we assign the imagination in representational seeing. While I was unfamiliar with Professor Spinicci's work, which is published in Italian, he was kind enough to send me an unpublished manuscript (Spinicci 2008) from which I have quoted at various points in the thesis.
- 2 This is not to underplay nuances in the interaction between recognition, attention to surface and *seeing-with*. With the representational seeing of painting, it is often difficult to disentangle perceptual and imaginative engagements with the work.
- 3 Fried notes that Judd champions 'artists whose paintings are on the verge of becoming objects' (Fried 1998, p. 312).
- 4 There is, for instance, an undivulged private iconography of architectural elements that I have become increasingly aware derive from childhood experiences, and corresponding recurrent dreams.

Introduction

- 1 While the thesis will concentrate on representational paintings, many aspects of the general argument may also be taken to also apply to drawings or prints (and, indeed, *some* aspects also apply to photographs and film, although these present their own distinct issues of spectatorship). By their very scale, however, drawings and prints (unlike many Renaissance paintings) do not tend to establish concrete ties to their place of reception; this aspect of my argument is therefore focused on painting, though it equally applies to 'situated' film practices.
- 2 This includes 'the contextual and institutional circumstances in which the work of art appears' (Kemp 1994, p. 366).
- 3 *Rezeptionsästhetik* (reception aesthetics) is to be differentiated from *Rezeptionsgeschichte* (reception history). While the former sees the work of art as the appropriate object of attention, positing the notion of an *implicit* or *ideal* beholder, the latter (in its various competing guises) focuses on actual beholders, on the history of a work's reception – see Kemp (1998, pp. 181-183).
- 4 Hegel argues: '[T]he separation in the work of art between its subject and the spectator must emerge and yet must immediately be dissipated because, by displaying what is subjective, the work, in its whole mode of representation, reveals its purpose by existing not independently on its own account but for subjective apprehension, for the spectator. The spectator is at it were in it from the beginning, is counted in with it, and the work exists only for this fixed point, i.e. for the individual apprehending it' (Hegel 1975, vol. 2, p. 806). Commenting on Hegel's position, Christiane Hertel claims that 'this idea of the implied spectator not only relates to the artist's practice, it also defines the beholder's authorship as an authorship that goes beyond the reconstruction of something already complete prior to its apprehension. In other words, in being dialogical and dialectical from the outset, artistic practice lacks closure' (1996, p. 27). Yet one might accept Hegel's notion of a dialogic role for the spectator without falling into a position that explicitly proposes a work's reception as a 'construction of meaning' on the part of the viewer. As we shall see, I believe imagination can provide just such a dialogic dimension.
- 5 Charles S. Peirce famously distinguishes between an *icon*, 'a sign which would possess the character which renders it significant, even though its object had no existence', an *index*, 'a sign which would, at once, lose the character which makes it a sign if its object were removed, but would not lose that character if there were no interpretant', and a *symbol*, 'a sign which would lose the character which renders it a sign if there were no interpretant' (Peirce 1985, pp. 9-10).
- 6 For a discussion of Dutch genre use of drape and curtain, see Martha Hollander (2002, pp. 69-76).
- 7 The distinction between reception aesthetics and reception theory was not clear at the time of Iser's

work. That it is reception history that Iser's criticisms are primarily aimed is evident when he states 'a theory of response has its roots in the text; a theory of reception arises from a history of reader's judgements' (1978, p. x). Nevertheless, Iser's phenomenological position is still distinct from that of Kemp's.

8 Iser here references Wimsatt (1967).

9 For an account of iconicity, see Wollheim's *The Thread of Life* (1984, pp. 62-96). Wollheim offers a linguistic clue to iconic states: 'What is the clue? The clue is a matter of whether the report of the mental state is of the form "I/you/he/she Vb'ed + that + embedded sentence" or of the form "I/you/he/she Vb'ed + direct object" (where the direct object is likeliest to be a nominalization). It is the latter form that is the favoured form. So, if I imagine something and imagine it non-iconically, I shall characteristically report this by saying something like, "I imagined that the horse fell down in the street". But if I imagine that same thing iconically, I shall be able to say, "I imagined the horse's falling down in the street"' (p. 64).

10 Following common practice, I use Wollheim's term *seeing-in* (see Wollheim 1980b) throughout the thesis, without taking on Wollheim's theoretical position on twofoldness.

11 See, for instance, Peacocke (1987), Budd (2004) and Hopkins (1998).

12 Paul Crowther would no doubt see this as an example of a major shortcoming in 'the existing literature's tendency to separate sharply the problem of what is distinctive to pictorial representation from the features which enable pictures to become art' (2008, p. 176). However, I am less convinced of the possibility of a 'unified theory', the focus of which is 'the notion of *pictorial space*' (p. 176). While my focus is also definitely on pictorial space, I do not see that such a notion, dependent upon the imagination, can explain the basic pictorial recognition that underlies depiction.

13 While disagreeing with aspects of Crowther's account, I share his regret that, with Merleau-Ponty's death in 1961, structuralist and nascent poststructuralist ideas in the 1960s overshadowed the impact of his phenomenology on art, with a corresponding shift away from perceptual and experiential concerns towards language based work (see Crowther 1993b, p. xi).

14 One might readily think of works by Bal, Barthes, Bryson, Claudel, Damisch, Deleuze, Derrida, Foucault, Gandelman, Grootenboer, Holly, Iversen, Krauss, Kristeva, Marin and Stoichita. Within the analytic tradition, the most prominent semiotic account of depiction is proposed by Nelson Goodman *Languages of Art* (1969). There exist a number of detailed critiques of Goodman's account, including those offered by Wollheim (1973, pp. 290-314), Walton (2004, 1990, ch. 3, section 7), Crowther (2002, appendix), Peacocke (1987), Schier (1986, ch. 1, section 6) and Hopkins (1998, ch. 1, section 3). A number of 'salvageable' aspects of Goodman's account has been defended by Dominic Lopes, who integrates both a perceptualist and conventionalist approach (1996, ch. 3).

15 Wollheim acknowledges that while some semiotic theories drop this 'commitment to pictorial structure', they deny a perceptual experience beyond mere recognition in that 'all the spectator has to do is to apply the rules of the surface, and the rules will take him, without any help from perception, to the thought of what is presented, which is his destination' (2001a, p. 15).

16 Grootenboer distinguishes Damisch's and Erwin Panofsky's positions thus:

If perspective can make a statement, then it must be a signifying system, indeed a network that *gives* meaning rather than a sign that *means* something. For Panofsky, perspective *means* something; it is an expression of a worldview by means of a symbol that stands for something else. For Damisch, perspective *gives* meaning; it is not a symbol but a structure, a paradigm (2005, 122).

17 Damisch here references Emile Benveniste's I-you polarity in *Problems in General Linguistics* (1971, p. 218). As Margaret Iversen notes, the book contains a very useful distinction for structuralist critical thought 'between two planes of utterance, *histoire* and *discours*', whereby: "The "historical" plane is used for the narration of past events. It is marked by the use of certain tenses and also by the exclusive use of the third person and the avoidance of locutions like "here" and "now" ... "Discourse", in contrast, includes "every utterance assuming a speaker and a hearer" ... It uses the first and second persons, "I" and a complementary "You"' (Iversen 1993, p. 129; Iversen cites Benveniste 1971, p. 207).

18 Elaborating on Damisch's notion of 'the thought of painting', Grootenboer observes that: 'The subject inscribed in the system is interpellated by the painting as much as s/he interpellates it, since s/he can only engage with the painting by becoming lost in it. Once one takes a position within this system, there is no escape from the symbolic order, or from language' (2005, 122). Grootenboer here references Damisch (1994, 389). For an earlier argument against aspects of Grootenboer's development of Damisch's position, see my essay 'Negotiating Painting's Two Perspectives: A Role for the Imagination' (2007).

As Iversen points out: 'Damisch's attention to the linguistic or structural or symbolic modality of perspective means that he tends to suppress the other two modalities of Lacan's psychoanalysis. The three registers of the symbolic, imaginary, and real intersect and overlap. I suggest that perspective can,

- so to speak, “appear” in all three registers’ (2005, p. 201).
- 19 Although as Crowther notes elsewhere, ‘there is no necessity that [pictures] should be created with [a] denotative end in view’ (2008, p. 179).
- 20 Bryson’s argument is a development of Barthes’s use of denotation and connotation to achieve the ‘effect of the real’ in Barthes’s essay ‘The Reality Effect’ (1989, pp. 141-149). Bryson argues that what Barthes fails to register, at least in terms of painting, is that ‘once installed, connotation then serves to eclipse denotation’ (1983, p. 65): unlike the univocal codes of denotation which transcend social context, the codes of connotation *always* appear in material practice (p. 72). For Bryson, it is this supposed excess of connotation that allows Western painting ‘to conceal its status as sign’ (p. xiii). It does so by exceeding the ‘fixities of representation’: with respect to realist painting, he proposes that ‘the “effect of the real” consists in a specialised relationship between denotation and connotation, where *connotation so confirms and substantiates denotation that the latter appears to rise to a level of truth*’ (p. 62).
- 21 Arguing against scrutiny theories, where criticism confining itself solely to the work of art, Wollheim maintains that this ‘ignores the interlock between perception and cognition’ (1993, p. 134). He proposes that perception is highly permeable to thought. The viewer’s ‘cognitive stock’ (i.e. knowledge, belief, and conceptual holding), whether gained through perception or from factors external to the work, affects *how* we see the painting. While it is unwarranted to demand that any item of cognitive stock ‘should actually have been gained in perception’ (p. 138), like some ‘evidence-gathering activity’, perception is, ‘in favoured circumstances, or when all the relevant information is in use, the process of understanding the work of art’ (p.142).
- 22 Jerrold Levinson makes a similar argument in ‘Intention and Interpretation in literature’, where he distinguishes ‘hypothetical intentionalism’ from both ‘*actual* intentionalism’ and *anti*-intentionalism’ (2004, p. 200). Levinson argues for an intention that is *hypothesized*, ‘given all the resources available to us in the work’s internal structure and the relevant surrounding context of creation, in all its *legitimately* invoked specificity’ (p. 201).
- 23 Of course, Hopkins accepts that some sculpture, such as in low relief, ‘may indeed incorporate a depiction point’, but argues that such works are ‘essentially pictorial’, and focuses his argument on sculpture in the round (2004, p. 163-164).
- 24 One might think of a Juan Muñoz sculptural group.
- 25 As such, my methodological approach echoes that of Iser in *The Act of Reading* (1978, p. xi).

Chapter One

- 1 Hopkins argues convincingly for the notion of two perspectives, noting that a picture is ‘on the one hand is a material object, on the other a representation’ (1998, p. 7). See also Budd (1992, pp. 259-260). As Patrick Maynard points out, however, not all drawings and paintings ‘depict’, and are therefore ‘absent’ (1994, p. 164 and 155). While acknowledging this important point, my primary concern in this thesis is with works that do depict an absent scene.
- 2 Maynard also refers to this feature as Richard Gregory’s paradox. While critical of some of its terminology, Maynard (1994, p. 155) quotes Gregory’s discussion of ‘The Peculiarity of Pictures’, from Gregory’s 1970 Faraday lectures:

Pictures have a double reality. Drawings, paintings, and photographs are objects in their own right – patterns on a flat sheet – and at the same time entirely different objects to the eye. We see both a pattern of marks on paper, with shading, brush-strokes ... and at the same time we see that these compose a face, a house ... Pictures are unique among objects; for they are seen both as themselves and as some other thing, entirely different from the paper or canvas. ... Pictures are paradoxes. No *object* can be in two places at the same time; no object can lie in both two- and three-dimensional space. Yet pictures are both visibly flat and three-dimensional. (1970, p. 32)

David Summers has likewise argued: ‘Images on surfaces entail a *double distance*; they necessarily place what is shown in the context of relations (planar or virtual) only possible by means of surface itself, at the same time that they inevitably present image and relations in the real, social space of the observer/viewer’ (2003, p. 338).

- 3 The term ‘bounded image’, which is utilised by Thomas Puttfarcken (2000), is taken from Meyer Schapiro’s 1969 essay ‘Field and Vehicle in Image-Signs’ (1985). Schapiro argues that ‘The student of prehistoric art knows that the regular field is an advanced artifact presupposing a long development of art’ (p. 209).
- 4 Like John Hyman, I dispute Wollheim’s notion that *trompe l’oeil* paintings are non-representational (Wollheim 1987, p. 62). As Hyman notes, the claim that they ‘repel’ attention to the marked surface

- 'distorts the aim and the effect of trompe l'oeil painting. The play element would be lost and the enjoyment of skill and virtuosity, which trompe l'oeil cultivates and caters to, would be frustrated if it were true' (2006, p. 132). It is rare that *trompe l'oeil* works 'baffle our attention' for long, and those that do suppress any implied depth. They do not therefore pose a real problem to a theory of depiction. Nevertheless, I will go on to argue that there is a difference between works that play on illusion and those that engage the imagination, despite difficulties in demarcating a line between the two.
- 5 As Crowther notes, the 'clarified presentation of a figure-ground relation' is basic to ordinary perception (2008, p. 183). As will become clear, I disagree with Crowther's conclusions with regard to this observation.
- 6 Of course, as Gilbert Ryle points out, the question as to "'Where do the things and happenings exist which people imagine existing?'" is a 'spurious question', as 'they do not exist anywhere' (2000, p. 232). Nevertheless, in adopting Merleau-Ponty's italicised term *where* whenever the question is raised in this thesis I seek to register that what is at issue is an *implied* rather than actual location.
- 7 As Budd notes:

A spectator experiences a picture that accurately depicts the spatial relations obtaining in a state of affairs as naturalistic in its depiction of distance not only to the degree that there is an experienced match of distance cues, but also (or alternatively) in so far as it encourages him to imagine the represented distances in the state of affairs depicted: the more vividly the spectator imagines the missing third dimension, the more intensely naturalistic he finds the picture's depiction of distance. (2004, p. 392)

- 8 Crowther makes very similar points in his 'Pictorial Space and the Possibility of Art' (2008). He argues that picturing: 'goes beyond the ordinary - highly mobile - conditions of perception, and sets pictorial space apart from that of reality. It offers a cognitively enhanced visual presentation of the subject, through a rendering which suspends (in virtual terms) that subject's necessary positioning in time. Suspension of this kind enhances the separateness of pictorial space from the practical world' (p. 191). Now, while my position echoes that of Crowther in terms of the importance of pictorial space, it differs in two important respects: (i) at least with some works, I contest aspects of Crowther's 'separating off' of the pictorial from the space of the viewer; and (ii) I differentiate between negotiating a work's figurative content and the intense experience of depth when we use a picture to imagine its pictorial space relative to a point of view. It is the role of perspective in augmenting such an experience that provides 'the systematic visual presentation of possible positions in three-dimensional space' (Crowther 2008, p. 188). While I agree with Crowther that relational foreshortening and linear perspective '*invests spatial systematicity itself with the character of visual presentness*', I do not believe that 'its potential for creative use' (p. 189) needs to be built into the unadorned account of depiction.
- 9 Although, this position can be indirectly represented, through devices such as the convex mirror on the rear wall of Jan van Eyck's *Arnolfini Wedding* (fig. 73), which reveals two witnesses framed by the open doorway.
- 10 Brendan Prendeville's contribution has been invaluable in helping me to clarify this aspect of the argument. While Summers does not share my notion of the role of imagination in such a relation, there are certain parallels in how he conceives of the relation between *real space*, defined by the '*cardinal structure of the human body*' to *virtual space* (2003, pp. 36-37). He argues:

Whatever illusionistic force they may have, virtual spaces show what is always at an unbridgeable remove, at a distance in space and time, another present, a past or future. Again, however, this is not a limitation. The same conditions under which virtual spaces cannot fully represent what they show mean that they may be specifically bounded and qualified apparent regions of space and time for an observer, within which things seem to exist in certain ways. That is, virtual spaces are always positively *not* real spaces, even though they seem to refer to spaces that are real, or might be real. (p. 44)

- 11 Occlusion shape refers to the 'two-dimensional aspects or appearances' of a 'three-dimensional body' (Hyman 2006, p. 75).
- 12 For a discussion on such a relationship between beholder and internal viewer see Michael Podro on Rembrandt (1998, pp. 79-80).
- 13 I do not believe that all frames, as Crowther suggests, separate off pictorial space from their viewer (2008, p. 191), although it is true that they act as organizational factors accentuating perspectival means of structuring pictorial space.
- 14 Such an absence is consistent with Wolfgang Kemp's notion of painting's 'constitutive blanks', which as he suggests, can be transformed into 'important links or causes for constituting meaning' (1998, p. 188). I will return to this argument in Chapter Four, when I take up Fried's antitheatricality argument



Fig. 73 Jan van Eyck: *Arnolfini Wedding* (detail; 1434), National Gallery, London.

- the Diderotian notion of works that deny the presence of a beholder before the painting. For Kemp's general argument on constitutive blanks, see 'Death at Work: A Case Study of Constituent Blanks in 19th Century Painting' (Kemp 1985). Here Kemp argues that such blanks 'principal function, like the aids to reception (i.e. what is determinate), is to link the communication between the picture and the beholder with the communication within the picture' (p. 109). Kemp's argument is a development of Iser's notion of the blank in literature (1978), which in turn references (and critiques) Roman Ingarden's use of indeterminacy (1973).

15 As Maynard notes, Panofsky himself admits problems with the 'window' simile in relation to such works as Jan van Eyck's *Virgin in the Church*; Maynard quotes Panofsky's recognition that 'the picture plane cuts through the middle of the space. Space thus seems to extend forward across the picture plane; indeed ... it appears to include the beholder standing before the panel' (Panofsky 1991, p. 60; cited in Maynard 1996, p. 37, n. 12). Nevertheless, Maynard observes that Panofsky 'still there distinguishes "imagined" space before from "represented" space behind' (p. 37, n. 12). I will argue that the imagination plays a role in both what lies in front of *and* behind the supporting surface.

In *The Poetics of Perspective*, James Elkins also cautions against Panofsky's excessive emphasis on Alberti's reference to the intersection as being like an open window, arguing that 'the window is one of a class of pedagogical figures that give the texts greater clarity' (1994, p. 47) - as with Leonardo's reference to a transparent pane of glass, this is 'a way of imagining perspective, not of learning its rules or drawing it' (p. 48). As for the mechanical devices appearing in Dürer's much reproduced prints (fig. 74), Elkins argues that: 'We have virtually no evidence that they were used for serious painting ... it is plausible to think that they were used principally as teaching aids rather than as substitutes for perspective proper' (p. 52).

16 The *projection* surface is what Alberti refers to as a cross section of a visual pyramid (1966, p. 52), and to which he uses the analogy of a finely woven veil (pp. 68-69). By no means all perspectival works are constructed using such a defined intersection plane in the manner suggested by Dürer's woodcut (fig. 74). Moreover, the terminology of projection planes is slippery. I take Maynard's (transmission) projection plane to refer to the purely hypothetical plane from which scaled measurements for forward or backward projections can be made. Yet two points are worth noting here: (i) a work might employ no such transmission plane, such as with so-called two-point or oblique perspective; (ii) a work might employ multiple planes (as my own experience in constructing architectural perspectives confirms). For a pluralist notion of the Renaissance conceiving of many compatible perspectives, rather than a single perspective, see Elkins (1994).

17 Partly because of limitations of space, and partly out of a reluctance to paraphrase arguments that are already comprehensively presented elsewhere.

18 The similarities do not stop Hyman labelling all three accounts 'subjectivist' (2006, n. 2, pp. 254-255). Lopes's account (1996) is also sceptical about *experiential* accounts of depiction, focusing upon what he terms aspectual information: pictures are conceived as providing informational and perceptual links to things or properties (pp. 151-152). For a convincing argument against Lopes's position, see Hopkins (1997).

19 Twofoldness is a term coined by Wollheim, and is central to his influential but flawed theory of 'seeing-in'. Wollheim argues that seeing-in is a special (and distinct) perceptual skill, which is 'prior,

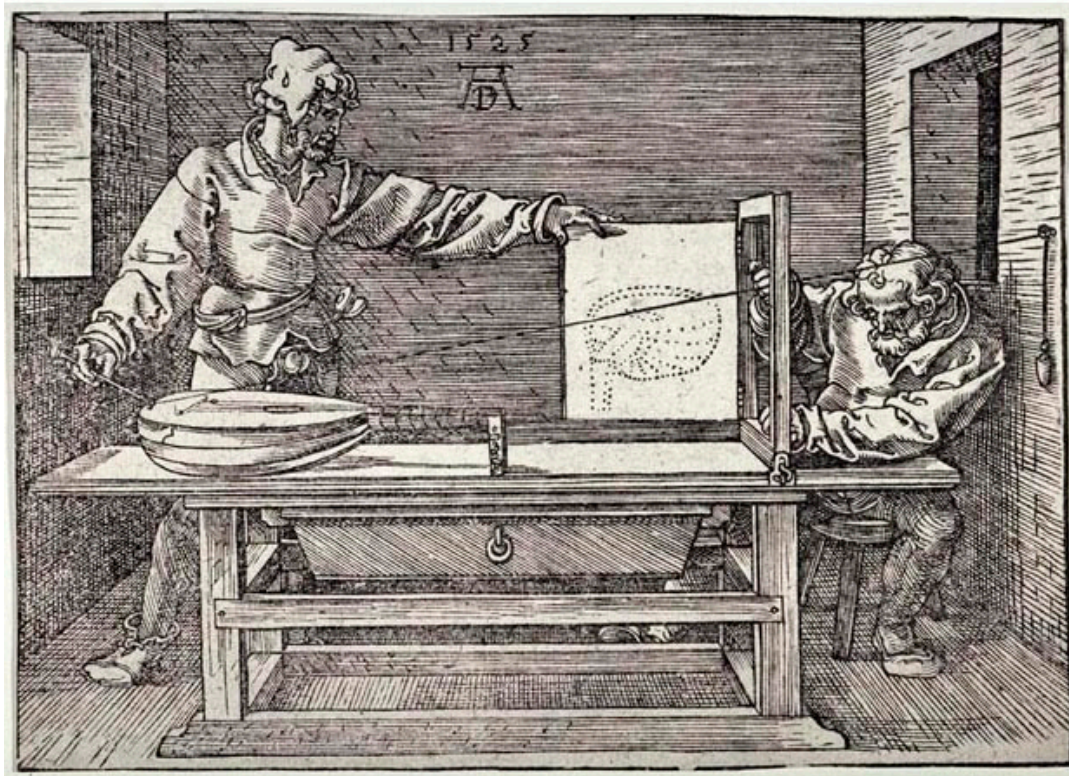

Fig. 74 Albrecht Dürer: woodcut from *The Painter's Manual* (1525), National Gallery of Victoria, Melbourne.

both logically and historically, to representation' (2001a, p. 19). It is a skill which allows us to see, for instance, the figure of a horse in something which is clearly not a representation, such as a damp stained wall or a cloud formation. For Wollheim 'if a picture represents something, then there will be a visual experience of that picture that determines that it does so', an experience that he terms 'the "appropriate experience" of the picture' (p. 13). Seeing-in provides such an 'appropriate experience' for pictorial representation, an experience which – unlike perception generally – involves 'a standard of correctness' which is set by the artist's fulfilled intention (1980b, p. 207).

Key to Wollheim's account of seeing-in is the notion of twofoldness:

What is distinctive of seeing-in, and thus of my theory of representation, is the phenomenology of the experiences in which it manifests itself. Looking at a suitably marked surface, we are visually aware at once of the marked surface and of something in front or behind something else. I call this feature of the phenomenology 'twofoldness'. (2001a, p. 19)

Contrary to Gombrich's assertion in *Art and Illusion* (1977), twofoldness requires the simultaneous perception of both the pictorial surface (the features of the medium, such as paint applied to canvas) and the thing being represented (what is seen). Wollheim's later versions of the concept conceive of twofoldness as 'a single experience' having two aspects, configurational and recognitional, which he claims are 'phenomenologically incommensurate with the experiences or perceptions ... from which they derive' (2001a, p. 20). Wollheim argues that these are not two experiences, but a single experience (1987, p. 46). With respect to painting, Wollheim acknowledges that one aspect of the experience can 'come to the fore' to the extent that 'twofoldness is lost, and then seeing-in succumbs to an altogether different kind of experience': but he argues that in such circumstances the pull of seeing-in will, in all probability, reassert itself (p. 47). But does Wollheim's notion of seeing-in solve the problem of how the thought of an absent object enters the experience?

In 'On Looking at a Picture' (1992), Budd claims that while seeing-in might permit 'simultaneous visual awareness of a surface and what is seen in it', Wollheim has not demonstrated that seeing what a picture depicts *requires* such simultaneous visual awareness (p. 267). Much of the problem stems from Wollheim's insistence that the experience of seeing-in is not just distinct but phenomenologically incommensurate with seeing face-to-face. As Budd notes, in Wollheim's later version of the theory Wollheim renders it 'illegitimate to enquire about the experienced resemblance between either aspect of the complex experience [i.e. the recognitional and configurational aspects] and the simple face-to-face experience after which it is described' (p. 270). This poses a real problem. Budd maintains:

The insistence that the recognitional aspect and the corresponding face-to-face experience are experientially incomparable undermines the force of the idea that for any recognitional aspect there is an analogous face-to-face experience after which it can be described. The recognitional aspect cannot properly derive the only description it can be given from an experience with an incomparable phenomenology: the alleged experiential incommensurability prevents the description of the one from being modelled on the description of the other – or, if it is so modelled, makes it inappropriate, indeed mistaken. Hence, the so-called recognitional aspect of seeing-in merely masquerades as an analogue of a face-to-face experience; and when the description it has wrongly borrowed is stripped from it, it not only has no other description to clothe itself in, but is revealed as having no nature of its own. (p. 271)

This is undoubtedly a serious flaw in Wollheim's position, in that Wollheim fails to explain why a picture of a horse 'sustains an experience permeated by the thought of a horse' (Hopkins 1998, pp. 16-17). The perceptual mechanisms that relate picture and absent object are unexplained.

But can we at least claim that what Levinson terms '*pictorial seeing proper*' (2001, p. 31) – the twofoldness implicated in the appreciating of a picture aesthetically – *requires* simultaneous visual awareness? This is a weaker claim than that made by Wollheim, as it does not establish twofoldness as a *necessary condition* for depiction. But even this claim is susceptible to Budd's contention that 'an alteration in the spectator's visual awareness would seem to be sufficient for the recognition of and consequent admiration of the artist's artistry' (1992, p. 267).

What, therefore, is left of Wollheim's twofoldness? Certainly, I would argue that *all* pictures retain an awareness of the marked surface, if not necessarily an aesthetic awareness. Moreover, some kind of twofoldness in Wollheim's sense is generally implied in the richer experience of *how* something is represented by the medium of paint. But is twofoldness, in any case, a matter or all or nothing? Lopes argues for a spectrum of possible engagements:

Pictures may be thought of as arranged along a spectrum, at one end of which lie *trompe l'oeil* pictures, experiences of which are experiences of their subjects, but which generally preclude, or at least suppress, experiences of decorated, marked, and painted surfaces. At some intermediate point on the spectrum lie pictures which afford one kind of experience or the other, but not both simultaneously. Gombrich's conception of depiction, taking Kenneth Clark's experiences stalking an illusion in a Velázquez painting as its model, gravitates towards this middle ground. At the other extreme lie pictures typical experiences of which are simultaneously experience of their subjects and experiences of flat, pigmented surfaces. Van Gogh's wheat fields, de Kooning's Woman series, and Lichtenstein's Ben Day-dotted paintings congregate at this pole, which may be described, very loosely, as 'painterly'. Experiences of these pictures may properly be described as twofold. (1996, p. 50)

Now, such a notion of a sliding scale is not in itself without merit. However, I would dispute Lopes's juxtaposition of *trompe l'oeil* with twofoldness. A more convincing scale would surely juxtapose *trompe l'oeil* (which suppresses but certainly does not 'preclude' attention to the surface) with works that *emphasize* qualities of the marked surface *over and above* any residual concern with subject (an extreme that might well include de Kooning, but *not* Van Gogh). Moreover, I would argue that it is precisely the middle ground where twofoldness is most apparent, or rather where there is a *switching* between alternating and simultaneous attention of surface and subject. This is the real lesson of Velázquez's *Las Meninas*.

20 Wollheim gives the following example: 'The spectator who is made aware that in the relevant panel of the S. Francesco altarpiece Sassetta uses to paint the cloak that the Saint discards, thereby renouncing his inheritance, the most expensive and most difficult pigment available will come to recognize a drama first in the gesture, then in the picture as a whole, of which he had been previously ignorant' (1980c, p. 193).

21 This repeats a point made by Lawrence Gowing, who notes of this hand the 'fortuitous bulbousness which has few parallels anywhere in art' (1997, p. 23). Gowing writes of Vermeer's vocabulary of representation:

His detachment is so complete, his observation of tone so impersonal, yet so efficient. The description is always exactly adequate, always completely and effortlessly in terms of light. Vermeer seems almost not to care, or even to know, what it is that he is painting. What do men call this wedge of light? A nose? A finger? What do we know of its shape? To Vermeer none of this matters, the conceptual world of names and knowledge is forgotten, nothing concerns him but what is visible, the tone, the wedge of light. (p. 19)

22 Walton proposes that on seeing a horse in a marked surface the viewer 'imagines her actual perceiving of the canvas to be an act of perceiving a horse' (1992, p. 285), whereby 'the phenomenal character of the perception is inseparable from the imagining which takes it as an object', bound together as 'a single phenomenological whole' (1990, p. 295). In a complex intertwining, 'the imagining partially constitutive of the recognitional aspect has as its object the perception that constitutes the configurational aspect' (p. 286). The experience is thus claimed as a perceptual experience where pictorial 'conventions' or 'rules' - part of our 'cognitive stock' - are internalised (p. 288).

Moreover, with regard to the twofold awareness of surface and pictorial content, 'the sense in which these are inseparable aspects of a single experience is given by the mutual interpenetration of the seeing and the imagining' (p. 301). Walton is therefore effectively proposing his own distinct version of Wollheim's twofoldness, and builds recognition into his model of depiction founded upon imagination.

However, as Hopkins has noted in relation to the viewer of a picture of a horse, 'Why should it be any more help, in the case of the picture, for her to *imagine* seeing the marks *to be* her seeing of the horse?' (1998, pp. 20-21) Imagination and the seeing of marks have their own distinct phenomenologies; unless the seeing of the marks and the imagining 'are transformed in their union, what is their phenomenology once changed?' (p. 21) Walton offers no adequate explanation, and his account is thus seriously flawed.

23 Wittgenstein's position is thus very different to that of Gombrich, who in *Art and Illusion* also notes of the duck-rabbit figure that 'we cannot experience alternative readings at the same time' (1977, p. 4). Unlike Wittgenstein, Gombrich takes the ambiguity inherent within such a picture-puzzle as 'clearly the key to the whole problem of image reading' (p. 198): we test hypotheses through the 'guided projection' onto an image of alternative readings as a 'test of consistency' (p. 200). It is a position of 'perceptual trial and error', that reveals Gombrich's indebtedness to Karl Popper (p. ix).

Gombrich famously emphasizes 'the beholder's share in the readings of images, his capacity, that is, to collaborate with the artist and to transform a piece of coloured canvas into a likeness of the visible world' (p. 246). It is an unapologetically illusionistic account, which stresses the subjective hypothesising of the viewer. The projection onto the marked surface is analogous to seeing face-to-face, thus disregarding the non-symmetrical nature of pictorial resemblance (that a picture might resemble an object in respect of certain particularities, but the three-dimensional object does not resemble the picture). The duck-rabbit analogy is used not in relation to the symmetrical situation of two competing perceptions of subject matter, but to suggest the impossibility of simultaneously attending to both the painted surface (the physical painting) and to what is represented in the illusion of painting (its subject matter or content) (p. 5): perceiving of the medium is separated out from the perception of the object of representation.

Gombrich's illusionist position is comprehensively argued against in Wollheim's 'Seeing-as, Seeing-in, and Pictorial Representation' (1980b), where Wollheim argues that 'it is Gombrich's failure to assign to the seeing appropriate to representations a distinctive phenomenology that impels him towards the view that there is nothing distinctive about the seeing of representations' (p. 215).

Chapter Two

1 Hopkins's argument, with respect to sculpture, references Susanne K. Langer, *Feeling and Form* (1953). For an earlier discussion of this theme, see Hopkins's 'Sculpture and Space' (2003).

2 Hopkins, I believe correctly, allows for more open-ended intentions by the artist in the imagining of such a spectator, particularly with regard to the viewer imagining *herself* engaging with the fictive scene rather than necessarily centrally imagining the protagonist from the inside. See Hopkins, 'The Spectator in the Picture' (2001, pp. 215-231).

3 Echoing the central theme of this thesis, in 'Painting, Beholder and the Self' Savile also asks whether 'it is not at least conceivable that ... we may come to understand paintings as depicting scenes that stretch right up to and even enclose their own beholders. Might not, on occasion, the external beholder and the internal beholder merge, or fuse?' (1992, p. 299) Savile applies these arguments to Fried's claim, after Diderot, that French painting between the 1750s and 1780s demanded 'the supreme fiction that the beholder did not exist' (Fried, 1980, p. 103). As I go on to describe in Chapter Four, there is a distinction between works where the internal and external fuse, and works where the external beholder is addressed as a purely external presence.

4 I have refined this aspect of my argument since it first appeared in my 'The Case for an External Spectator' (2008).

5 In Shearman's terms, the works are *transitive*, in that they are 'completed only by the presence of the spectator in the narrative' - see John Shearman, *Only Connect: Art and the Spectacle in the Italian*

- Renaissance* (1992, p. 33). These are works that engage a beholder as a participant or witness: 'the viewer is located in the event, and the described action is transitive, completed outside itself in another focus in a shared space' (p. 39). In comparing Shearman's 'implied spectator' to Wollheim's internal spectator, Caroline van Eck argues that Shearman fails to distinguish between internal and external spectators; while I agree with this, I believe she exaggerates the distinction between the compositional devices of works with 'implied spectators' and the essentially psychological engagement typical of Wollheim's 'internal spectator', thus separating out the spatial and psychological attributes of such imaginative engagements. See 'The Case for the Internal Spectator: Aesthetics or Art History?' (2001, pp. 200-214).
- 6 For all his invaluable insights into the parallel developments of early Renaissance architecture and painting, Wittkower, for instance, claims that *Trinity* obliterates 'the borderline between real and painted architecture: the beholder looks, as it were, into a real chapel' (1978, p. 134).
- 7 Despite offering us the means to do so, Sandström can be inconsistent in distinguishing between those works that serve illusionist ends, and those where the differentiation serves the picture's content.
- 8 Goffen argues that this is Adam's fictive tomb – see Rona Goffen (1998a, p. 14).
- 9 For Alois Riegl, works described as having a 'closed internal coherence' are founded on the reciprocity of pictorial elements contained within the picture, whereas works having an 'external coherence' are completed only by the presence of a spectator, and establish a rapport with the viewer. As we shall see, Riegl believes that certain painters combine both. Unfortunately, in defining an external coherence, Riegl (like Shearman) fails to distinguish between internal and external spectators. See Riegl, *The Group Portraiture of Holland* (1999).

Chapter Three

- 1 References to viewers tend to occur in relation to perspective, such as in *The World of Perception*, where Merleau-Ponty argues that works of 'classical art' (of which he offers no examples) 'remain at a distance and do not involve the viewer': rather, they imply a 'gaze fixed at infinity' (2004, p. 53).
- 2 We have seen how this finds echoes in the work of Merleau-Ponty's one time student, Damisch.
- 3 This anomaly at the heart of Merleau-Ponty's later writing is replicated by Crowther. Crowther, for his part, ends up arguing a position that is reminiscent of Fried's criticism of the 'theatricality' of minimalist sculpture in *Art and Objecthood* (1998). Critical of many aspects of Fried and Greenberg's ahistorical formalism, Crowther nevertheless replicates their arguments for the self-contained nature of fictive space, as a 'symbolic extension of perception'. Thus we recognize pictorial space 'as one that is symbolic and thence not continuous with the real network of spatiotemporal relations which our body inhabits' (2002, p. 19). For all Crowther's emphasis on reciprocity of object and subject, the ontological reciprocity is held within the symbolic world of the virtual or fictive space: this ontological reciprocity is not replicated by the relationship between an artwork and spectator. Thus, while Riegl's notion of external coherence is briefly introduced in *The Transhistorical Image* (2002), as one of Crowther's compositional categories (pp. 87-88), it is treated as marginal to Crowther's overall argument. Similarly, the issue of spectatorship is barely addressed in Crowther's *Art and Embodiment* (1993a), despite the subject of the book. So while the artwork 'reflects our mode of embodied inherence in the world' (p. 7), it does not replicate it. Crowther's position here reveals his commitment to a Kantian notion of both a 'logical and psychological sense of disinterestedness' (p. 20). So, a work's formal qualities are 'ontologically neutral, that is, the grounds of their appreciation do not logically presuppose any belief in (as Kant might put it) the "real existence" of the object sustaining the appearance' (p. 21). While such an approach is entirely appropriate to some works of art, for others it severely limits the degree to which the spectator's reality (her situatedness) might be incorporated within the work, *through* an imaginative engagement.
- 4 Of course, this a radical empiricism which substantially departs from both the classical empiricism of Berkeley and Hume, and that of the Logical Positivists. As Baldwin argues in his introduction to *The World of Perception*, Merleau-Ponty 'follows Husserl in taking it that the relationship between perception and all other modes of thought, including science, is one of "Fundierung"' (foundation), which involves a kind of rootedness that does not restrict the capacity for more sophisticated articulations of experience in the light of deeper understandings of the world. So he consistently rejects those forms of empiricism which aim to restrict or reduce the contents of thought to possible contents of experience' (2004, p. 8). Moreover, Baldwin argues that Merleau-Ponty gives a distinctive twist to the Kantian notion that while 'the empiricists were largely right about empirical concepts, the rationalists were largely right about a priori concepts', by maintaining that 'our embodiment is integral to the role of a priori concepts in sense experience' (p. 9).
- 5 In Chapter One I questioned the subjectivity of such a position, in that clearly properties such as occlusion shape *are* objective properties of the object perceived.

- 6 The weakness of this view, as Kelly points out, is that 'the real object is *never* seen' (2005, p. 99).
- 7 Merleau-Ponty develops this account of how, for instance, the hand prepares itself to grasp an object in the chapter on 'The Spatiality of One's Own Body and Motility', in the *Phenomenology of Perception* (2002, Part 1, ch. 3).
- 8 As Husserl argues, where we '*hypothesize* the side's existence, not because we *perceive* it' (Kelly 2005, p. 96).
- 9 Sartre is certainly amongst the most insightful writers on the imagination, devoting over a decade's work on the subject. It is therefore no surprise that Merleau-Ponty's references to imagination consistently cite his fellow philosopher. This is particularly true of the *Phenomenology of Perception* (2002), where Sartre's account of the phenomenology of imagination is largely taken to be definitive.
- 10 There is a parallel here with Podro's notion of alternative orientations: 'We may see the compositional device of intimating the viewer's counterpart within the image as a special case of a more general way in which Rembrandt's compositions form themselves round their subject, suggesting the spectator's view is one of several possibilities; the effect is that the subject is not felt to be absorbed or summated in the way it is represented, in the particular view' (1998, p. 65).
- 11 Crowther is a rare example of someone who combines aspects of analytic philosophy with the 'corporeal phenomenology' of Merleau-Ponty (Crowther 2002, p. 4). While noting 'its admirable orientation towards conceptual distinctions', Crowther argues that analytic philosophy 'often overlooks key questions of ontology, and, in particular, that reciprocity between subject and object which is deeply involved in aesthetic experience' (2004, pp. 34-35).
- 12 In holding that such perceptual experiences are belief-independent, Peacocke's position corresponds with that of Gareth Evans, in *The Varieties of Reference* (1982). See also Sean D. Kelly, 'The Non-conceptual Content of Perceptual Experience' (2001).
- 13 We might compare Peacocke's notion of a scenario labelled with bodily axes - a 'distinctive kind of knowledge' which like 'the location of a limb is given egocentrically, in relation to the subject's body' (1992, p. 92) - with Merleau-Ponty's argument that: 'My whole body for me is not an assemblage of organs juxtaposed in space. I am in undivided possession of it and I know where each of my limbs is through a *body image* in which all are included' (2002, p. 113).
- 14 For a defence of this argument, see Kelly (2001).
- 15 In 'Imagination and the Self' (1973, ch. 3), Bernard Williams introduces an imagining 'in which I visualise a world in which I am acting, moving around, seeing things, and so forth - a form of imagery involving, very often, kinaesthetic imagery of various sorts' (p. 38). Williams acknowledges that in imagining being a champion racing driver 'this could involve kinaesthetic imagery of tension, hands clasped on the steering-wheel' (p. 38). What I am arguing for is a form of visualizing where some of this kinaesthetic imagery is not so much acted out in space, as experienced as a potentiality.

Chapter Four

- 1 This is not to argue that extrinsic conditions cannot impact upon a work's reception: i.e. its placement upon the wall, or in relation to other works within a gallery, its background colour or lighting conditions.
- 2 A similarity with Wölfflin's argument in the *Principles of Art History* (1950) was noted in Chapter Two. To repeat the earlier point, Wölfflin distinguishes between the tectonic and a-tectonic: where the work is constructed just 'for this frame', as a 'self-contained entity', appropriate for the ceremonial, against the notion of the 'open' composition, where 'the filling has lost touch with the frame' (p. 125). Wölfflin would classify a painting such as *Trinity* as 'closed' or 'tectonic': such works are predominantly 'stable', organised around a central axis (p. 125), and crucially 'the filling relates to the given space ... that is the whole is made to look as if this filling were just made for this frame' (p. 131). By contrast, an 'open' or 'a-tectonic' composition is one where 'the general tendency is to produce the picture no longer as a self-existing piece of the world, but as a passing show, which the spectator may enjoy only for a moment' (p.126).
- While rejecting Wölfflin's stylistic approach, Alpers similarly maintains a geographical distinction between what she terms the 'art of describing' typical of the northern tradition, and the narrative art of Italy (1989, p. xx). She distinguishes between Italian works employing an Albertian frame, conforming to a notion of a 'prior viewer' (p. 43), where the spectator is peculiarly privileged in being in a situation prior to the world and 'commanding its presence' (p. 70), and Dutch painting where there is 'a prior world seen' (pp. 41-42).
- By contrast, Puttfarken has argued that many of these perceived differences in pictorial ordering between the North and South are in fact questions of scale - see Thomas Puttfarken (2000, p. 167). In broadly agreeing with Puttfarken approach, I have been arguing that with certain works such differences

might also be couched in terms of the nature of a work's implied spectator (a factor intimately tied to the question of scale). And here it is worth noting that while it is undoubtedly true that the notion of situated painting might be applied to Italian altarpieces, a painting such as Rembrandt's *The Syndics* (fig. 17) might also legitimately be seen as engaging an external spectator (as we shall see).

Nonetheless, we should also acknowledge real distinctions in the relation between painting and architecture that emerges in Italian and Dutch art. As Rudolf Wittkower observes, one consequence of Italian Renaissance architects such as Brunelleschi wanting their buildings 'to be looked at as if they were projected on to an intersection' is that 'the difference between architecture and painting becomes one of artistic medium rather than of kind' (1978, p. 134). If architecture was to be viewed as painting, paintings such as *Trinity* were also to be viewed as architecture (without ever negating the role the two-dimensional surface of the wall plays in differentiating realms). As such, while Masaccio's illusory painted chapel (a work inspired, at the very least, by Brunelleschi's architectural ideas) was hugely influential in terms of perspectival painting, its impact was equally felt in church architecture. Shearman provides one such example in the Cardini Chapel (Pescia, San Francesco) by Andrea Cavalcanti (known as Buggiano) and Brunelleschi (1992, pp. 64-65). That an illusory *painted* architecture should inspire such an important new architectural type is systematic of a more general Renaissance questioning of the boundaries between architecture and painting. One aspect of this was the development of a metrical architecture to be viewed *as though it were a painting*. As Wittkower notes of Brunelleschi's church of San Lorenzo, it is designed (with the square grid of its floor, its delineated central axis and the regular rhythm of its columns) as if to be seen through a perspective screen, its parallel lines retreating to a single vanishing point (1978, p.133). It visually asserts the significance of linear perspective not only for painters but also for early Renaissance architects. Linear perspective offers theoretical justification for the use of absolute proportions in architects' elevations; it guarantees that absolute measurements can be perceived from 'subjective' viewpoints as they recede in space (see Wittkower 1978, pp. 125-135).

3 As Goffen notes, the 'altarpiece has been removed from its frame and perhaps from its original site in the church' (1989, p. 171). Nevertheless, the work's current frame replicates the original intent, and therefore still might serve by way of example.

4 Although sometimes, as in the Bellini, the work offers a glimpse into a fictional landscape beyond the confines of the painted chapel.

5 In certain instances, such figures 'become vehicles of identification, figurations of the beholder in the painting, representatives of a *personal perspective*' (Kemp 1998, p. 187).

6 The centric point is Alberti's term for what by the seventeenth century becomes known as the vanishing point. For the importance of registering the distinction see Elkins (1994, p. 8), but for convenience sake I generally use the later term. In fact, the *San Zaccaria Altarpiece's* vanishing point is somewhat higher than eye level, but see note above about the repositioning of this work.

7 This unhistorical association of early Renaissance perspective with seventeenth century Cartesian rationalism, where analytic geometry *is* taken by Descartes as a model for his dualistic philosophy, is repeated by historians like Martin Jay, who take their notion of Cartesian perspectivalism directly from figures like Bryson. Thus Jay writes: 'The abstract coldness of the perspectival gaze meant the withdrawal of the painter's emotional entanglement with the objects depicted in geometricalized space. The participatory involvement of more absorptive visual modes was diminished, if not entirely suppressed, as the gap between spectator and spectacle widened. The moment of erotic projection in vision ... was lost as the bodies of the painter and viewer were forgotten in the name of an allegedly disincarnated, absolute eye' (1988, p. 8).

8 Bryson's assertion is based on Alberti's description of a picture as a cross section of a visual pyramid (1966, p. 52), the apex of which is 'located within the eye' (p. 48). That the vanishing point curiously '*incarnates* the viewer, renders him tangible and corporeal' (1983, p. 106) is for Bryson the outcome of the failure of even the most 'Albertian' painters to resolve 'the relation between the purely fictional vanishing point, and the position *physically* to be occupied by the viewer' (p. 107). Yet the pyramid or cone of vision is not Alberti's invention, but is taken from the medieval study of optics, a theory of vision known as *perspectiva*. Alberti devotes much of Book 1 of *De pictura/Della pittura* to a consideration of optics (*perspectiva naturalis*). James Ackerman notes in 'Alberti's Light' (1991a, pp. 60-61) that there is a tendency for modern readers to ignore this section, and to focus almost exclusively on Alberti's perspective construction (*perspectiva artificialis*). Alberti relies on theories of vision that extend back to Euclid, Ptolemy and Galen. As Ackerman notes: 'These writers, all of whom were known throughout the Middle Ages, and most other ancient students of optics, proceeded on the hypothesis that vision is made possible by rays of light emanating from the eye to reach the objects of vision' (p. 62). Alberti's description of the visual pyramid, with its rays of light classified into *Extrinsic rays* (which describe outline), *median rays* (which describe surfaces and colour) and a single *centric ray* (the most active and strong, and which enters the eye at a right angle), is directly derived from such optical theories, and Alberti adds nothing new (Alberti 1966, pp. 46-48). He simply adapts it as a pedagogical tool for

visualising his perspective construction and for demonstrating its proof based on simple Euclidean geometry. In asserting the pre-eminence of the centric ray 'Alberti is simply transmitting a principle of medieval optics' (Ackerman 1991a, p. 67).

Far from aiming at a 'dimensionless punctuality', in locating the 'cuspid' (the apex of the pyramid) in the eye, Alberti is therefore grounding his system of perspective construction in an already established theory of vision. His real theoretical breakthrough, what Ackerman rightly refers to as 'his most influential and revolutionary contribution to the history of art' (p. 76), is to conceive of a picture as an intersection of the visual pyramid, for which Alberti uses the analogy of a finely woven veil (Alberti 1966, pp. 68-69). Alberti's concern is to establish a system of proportional triangles so that 'every cross-section of the visual pyramid which is equidistant to the plane of the thing seen will be proportional to that observed plane' (pp. 53-54). Alberti uses the simile of a small man being proportional to a large man in terms of relative sizes of 'palm' and 'foot' as a way of explaining proportionality (p. 53). This is a clue as to his real intention.

Wittkower's essay 'Brunelleschi and "Proportion in Perspective"' (1978, chapter 5, pp. 125-135) sets out with admirable clarity the importance of the 'proportionality of similar triangles' to Alberti's system of constructing perspective. Crucially, this offers Alberti a 'proof of representational correctness' (p. 127). In a revealing passage Wittkower argues:

We may now return to the example of the tall and little figure and state what Alberti only implied. We can imagine the triangles formed by the figures as visual pyramids with the apex at the vanishing point. Then, instead of seeing two figures objectively differing in size, we seem to look at figures of equal size placed at different distances in space from the eye of the observer. If on the other hand, we imagine the eye at the apex of the triangle, the smaller figure will be the projection of the larger on the intersection of the pyramid of sight. As long as the two figures can be defined by similar triangles, they will be proportional to each other. It appears that the same theorems of plane geometry unite proportion and perspective (p. 127).

This correlation of 'vanishing point' and eye position is critical to understanding the construction of Alberti's system and its grounding in Euclidean geometry. The theoretical repercussion of such a correlation is not the reduction of an embodied viewer to a disincarnated, absolute and fixed eye *in front of the painting*, but the establishing of a common foundation for both proportion and perspective.

9 Puttfarken argues:

The visual projection of a coherent pictorial world assumes a fixed standpoint from which it can take place. Again, this is not necessarily our real standpoint in front of the picture (since we can change this without changing the picture). In perspectival pictures, this standpoint is defined by the point occupied by the viewer's eye and its distance from the picture. All the necessary information about eye-point and its distance is embedded within the information provided for us in the picture plane. Projection is a reciprocal process: as we project the objects of the pictorial world into their appropriate place and distance, they *in toto* project us, as the viewer, into the place from which they are seen. We *find* our appropriate position *vis-à-vis* the pictorial world by constituting that world in projective vision. It is possible that we may find the standpoint prescribed by the picture coinciding with our real position in front of it ... In most cases that does not happen. (2000, pp. 26-28).

While Puttfarken is right to note that in most cases this correlation does not happen, in works implying external beholders it frequently does.

10 Sandström believes the consideration of such functional devices to be genuinely a problem of aesthetics as well as art history, and indeed he sets out a position that has repercussions for both a theory of representational seeing and for an aesthetics of reception. In his own version of painting's double aspect, Sandström brings together: (i) the reality-effect of painting, the relationship between the picture as surface and the picture as implied space, and (ii) the questioning of the boundary between the virtual space of painting and the physical space of architecture (1963, pp. 7-10).

11 Wolfgang Kemp argues that Shearman fails to distinguish between the two variations of reception theory: *Rezeptionsästhetik* (reception aesthetics) and *Rezeptionsgeschichte* (reception history) (1994, p. 365). Kemp argues that if in the early chapters Shearman works reception-aesthetically, in that the topic is 'Renaissance art's intensified address of the viewer', corresponding to notions of an implicit viewer; with the latter chapters he switches to reception-historical observations, in that 'the topic is no longer the activation of the link between viewer and work, but rather the competence of the viewer, and the question of how spectators make meaning based on their contemporaneity, their previous knowledge, their social or spiritual status, or their gender' (pp. 365-366).

12 Shearman uses the term 'liminal' to 'describe that zone of the real space which lies at the threshold of the painted space, but is not part of the painted space' (1992, p. 59).

Fig. 75 Titian: *Pesaro Altarpiece*, earlier stage according to Sinding-Larsen (drawn by Puttfarken).

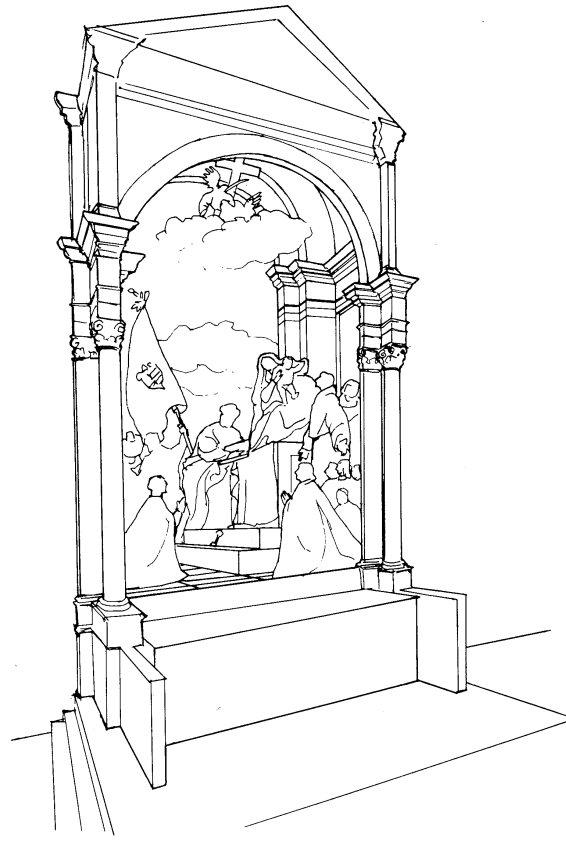

- 13 As Wolfgang Kemp notes, the notion of the spectator's 'natural experience of the space' needs some clarification. What is not disputed is that Domenico Lenzi and his wife - the likely patrons - are 'interred in the pavement before the fresco' (Goffen 1998a, p. 13). Goffen argues that the proximity of the now destroyed tomb suggests that *Trinity* was commissioned as a mural for the Lenzi family funeral chapel, and indeed 'the fresco's funerary function is visualized in a most dramatic way' by the illusionistic sarcophagus, on which 'a skeleton is laid to rest' (p. 13). What is subject to dispute is the presence of a real altar; Goffen surmises that if such an altar had been installed, then 'the *Trinity* would have become visible in its entirety only when the beholder knelt at the altar - that is, only kneeling, could one see the skeleton' (pp. 14-15). Kemp makes an analogous suggestion, when he proposes that 'we must assume two different types of recipients': 'close recipients, who include the priest and the churchgoers participating in the Mass with him, or praying before the altarpiece', and a more distant group, 'those who perceive the work at a greater distance, standing or walking under the arcade or in the nave', and to whom constitute 'the focus of the fresco's deployment of central perspective, as well as the total effect of the fictive space, of the pseudo-chapel' (1994, p. 367). By contrast, Shearman (for reasons that escape Kemp) 'rejects the functional determination of the fresco as altarpiece' (Kemp 1994, p. 367). Shearman doubts whether there is sufficient evidence for a real altar, and argues that 'a real altar seems rendered redundant by the fiction': and 'fictional altars cannot be consecrated' (1992, p. 66). Shearman's position here is supported by John Spike (1996, p. 174). What is not in doubt is the role played by the painted architecture. As Goffen notes, 'fictive architecture becomes a protagonist, playing a role nearly as important as that of the figures themselves and fully consonant with theirs' (1998a, p. 20).
- 14 That the work incorporates donors into the picture is in itself somewhat unusual for a Venetian altarpiece. For a discussion of this point, see Puttfarken (2000, 137-147).
- 15 Interestingly, Puttfarken argues that as such the *Pesaro Altarpiece* still represents the dominance of three-dimensional spatial disposition over two-dimensional composition, contradicting the emphasis frequently placed on its diagonal compositional thrust.
- 16 Puttfarken here references Staale Sinding-Larsen's account (1962) of the earlier version of the work (fig. 75) - see Puttfarken (2000, p. 145, fig. 84).
- 17 Something impossible to capture in photographs.
- 18 While some earlier Italian and Netherlandish works might arguably be said to imply internal spectators,



Fig. 76 Jan van Eyck: *Arnolfini Wedding* (1434), National Gallery, London.

such as Jan van Eyck's *Arnolfini Wedding* (fig. 76, 73) and Piero della Francesca's *Madonna di Senigallia* (fig. 53), it is only with the seventeenth-century works of Rembrandt, Vermeer and Velázquez that such a notion is first systematized, and the complexities of the notion played out.

19 For an account of the arguments underlying the work's reception, see Puttfarken (2000, pp. 12-17).
 20 I take this suggestion from Georgina Cole's essay "'Wavering Between Two Worlds": The Doorway in Seventeenth-Century Dutch Genre Painting' (2006).

21 A rather ingenious adaptation of a *trompe l'oeil* curtain is provided by Pieter de Hooch's *The Interior of the Burgomasters' Council Chamber in the Amsterdam Town Hall with Visitors* (fig. 77). Here the curtain, a later addition according to radiographs (Gaskell 1990, pp. 284-289, cat. 62), is both an 'illusory' cover to the work we look at as an external beholder, but can also, ambiguously, read as the pulled back cover to another *unrepresented* painting. This lies above 'our' heads, if we imagine ourselves as an implied internal beholder (our presence engaged by the young girl). Indeed, the surface on which this work rests might intriguingly be interpreted as the *reverse* of de Hooch's work. Peter C. Sutton reveals the absent painting, after Ivan Gaskell (pp. 284-289, cat. 62), as a work by Govaert Flinck (Sutton, 1984 pp. 156-158). Sutton suggests that the rear wall lies to our backs, almost to the point where we stand within the room's fireplace, and the work hence 'plays on the viewer's special knowledge of the room' (p. 158). He further notes how the curtain plays another crucial role in preventing a 'conspicuous distortion' by covering 'the spring line of the ceiling and much of the back left corner of the room' (p. 158). Nevertheless, the notion we stand, as it were, *behind* the picture plane of the unrepresented work - a work that the viewer in the work looks up at so intently - is certainly intriguing, and is borne out by my own experience of the work. And indeed Podro, with respect to Rembrandt, also talks about the suggestion 'of the viewer's position being mirrored on the other side of the dominant plane of the surface' (1998, p. 65). Regardless, as Sutton notes, the work 'cunningly serves to engage us in the scene by not only reminding us of unseen aspects of the chamber, thus subsuming us in the imaginary space, but also by calling attention to our own act of viewing a painting' (1984, p. 158).

22 In an earlier work, Vermeer also adopts a *trompe l'oeil* curtain in *A Woman Reading at the Window* (fig. 78). Here the clash between two contrasting barriers to our participation is revealing. Unlike the playful tension of Maes's *Eavesdropper*, the work lacks resolution: the status of the curtain, which X-rays reveal as a later addition, is inconsistent with the role played by the disturbed table. While the former excludes the external spectator, the latter suggests, while simultaneously denying, an internal presence. The work perhaps marks a crucial, if not entirely successful, problematization of the presence of the beholder in Vermeer's *oeuvre*.



Fig. 77 Pieter de Hooch: *The Interior of the Burgomasters' Council Chamber in the Amsterdam Town Hall with Visitors* (c. 1663-65), Museo Thyssen-Bornemisza, Madrid.



Fig. 78 Johannes Vermeer: *A Woman Reading at the Window* (c. 1657), Staatliche Gemäldegalerie, Dresden.

- 23 While I have found Alpers's distinction between two modes of representation extremely useful, it is clear from this discussion that it is not the case that all Dutch works necessarily renounce the assumption behind the Albertian mode of 'the existence of viewers prior to and external to' the picture (1983, p. 37).
- 24 Podro notes a parallel case with Rembrandt's *Women in Bed (Sarah, Wife of Tobias)* (fig. 79), but one where our presence is not so much ignored as negated. Podro observes: 'We are aware of the woman observing an event we cannot see ... [which] continues beyond the frame, in the space in which we stand, and because of the approximation of the fictive setting to the real frame and the proportion of the surface occupied by the figure we imagine her as seen from very close. What is arresting here is that despite the sense of closeness and imagining the scene thus extending into our space, we have no role and can imagine no position for ourselves in relation to her' (1998, p. 79). There are also parallels with aspects of Wollheim's account of internal spectatorship with respect to Manet, in *Painting as an Art* (1987, pp. 141-164).
- 25 This latter relationship introduces additional complexities, which I do not have space to discuss. For a particularly illuminating account of just such a relationship, see Alpers's 'Viewing Making Painting' (2001). Alpers investigates the dynamic between Rembrandt and his common-law wife Hendrickje Stoffels in Rembrandt's painting *Bathsheba*, where Rembrandt 'depicts her as resisting the roles assigned: The painting represents not his successful projection on to her, but someone who resists projection, someone he acknowledges as separate from himself' (p. 176).
- 26 Steadman's reconstructions also confirm Snow's argument that Vermeer manipulates the subtle twist of the reflection towards the man.

Chapter Five

- 1 In a cautionary note, Elkins suggests that before Foucault the painting 'had to do with the Spanish court, with decorum and etiquette, and with transcendental technique: now, it has to do with cat's cradles of inferred lines, relative positions, possible viewers, and the many logical forms that follow from them' (1999, p. 42).
- 2 A point made by Iversen (1993, p. 131).
- 3 Given its apparent size, Searle rather unconvincingly claims this canvas to be none other than Velázquez's *Las Meninas* rather than the fictive portrait of the royal couple (1980, p. 485). Moffitt effectively disputes this claim, on the grounds that the dimensions do not match (1983, pp. 286-287).
- 4 With reference to the inscription above the mirror, which reads *Johannes Van Eyck fuit hic* (fig. 73), Damisch notes: 'Hic means *here*, in the spot from which I see it, as reflected, and not *there*, where I see it to be by means of the mirror, in the position of the witness facing this man and woman whose portrait was executed by Van Eyck, if we are to accept Panofsky's classic reading, as a kind of marriage certificate' (1995, pp. 130-131). Damisch also points out possible implications of the fact that there are *two* witnesses, in that we identify with two vanishing points - 'we must seriously consider the possibility that the multiplicity of vanishing points, all situated in the same area of the painting, held to be characteristic of early Flemish painting might indicate not a problematic lack of systematic coherence but a deliberate choice, an acknowledgement or affirmation of the different perspectives of different subjects, first of all of different spectators simultaneously looking at the same painting' (p. 131). It is an intriguing, if not altogether convincing, proposition.
- 5 The sizes of the reflected figures are too large, given the dimensions of the room, to be a direct reflection of the living royal couple. With Snyder and Cohen's argument, the problem is somewhat alleviated as the viewing distance is reduced. George Kubler (1985) claims that the mirror is in fact 'a painted image of the King and Queen, painted on a small canvas as if seen in a mirror' (p. 316). This, however, would not explain its strange 'glow' relative to the other paintings on the rear wall. That Velázquez is not averse to manipulating a reflection is borne out by Velázquez's *Venus and Cupid*, the so-called '*Rokeby Venus*' - a work that manipulates the angle of the mirror in order to engage the viewer and the size of the reflected image.
- Snyder and Cohen's version is consistent with the earliest account of the painting, by Antonio Palomino in Part Three of *El museo pictórico y escala óptica*, published in Madrid in 1724 (see Jonathan Brown 1986, pp. 253-259). As Brown notes, 'Palomino is confident that the mirror-image reflects the large canvas on which the artist is working' (p. 257).
- 6 This error is repeated by Steinberg (1981, p. 51), although Steinberg's own position actually predates all the accounts thus far referenced, though it was published later.
- 7 The reconstruction was in fact undertaken for Snyder by Elkins (Snyder 1985, p. 565).
- 8 The room in question is the *Pieza Principal* in the *Cuarto Bajo del Principe* on the ground floor of the Alcázar - see Moffitt (1983, pp. 278-287). See also Jonathon Brown (1978, p. 87, 1986 p. 256). Velázquez



Fig. 79 Rembrandt: *Woman in Bed (Sarah, Wife of Tobias)* (c. 1645), National Gallery of Scotland, Edinburgh.

himself was extensively involved in the reconfiguration of these rooms. Martin Kemp's reconstruction in *The Science of Art* (1990, p. 107, figs. 202, 203), based on a 'procedure of working from the picture' (p. 350, n. 27), arrives at a plan that differs from the historic chamber in that it has one window too few. It is difficult to see just how Kemp arrives at this particular solution, as the position of the West wall cannot be determined from the depiction as such. Moreover, Kemp's perspectival analysis (p. 107, fig. 203) provides a viewing distance that exceeds that of his diagrammatic plan (p. 107, fig. 202), and is in fact more consistent with Moffitt's positioning of the 'Royal Spot' (1983, p. 283, fig. 3). I am inclined to accept Moffitt's reconstruction, regardless of any validity to the claim that 'it is highly likely that Velázquez utilized a camera obscura in the construction of the picture' (p. 287).

9 From a room we know as the *Pieza de la Torre Dorada*.

10 Iversen argues that, in contrast to an 'allegory of classical episteme' what Steinberg's reciprocity suggests, in Riegl's terminology, 'is the diminishment of internal coherence and the compensating shift toward connection with those in the imagined space in front of the picture' (1993, p. 145). Echoing, but differing from Alpers, Iversen goes on to suggest that if Foucault and Steinberg's 'radically incompatible interpretations ... face off on either side of the divide we have been calling internal and external coherence, or *histoire* and *discours*, or "in itself" and "for others"', then 'the fact that both sides of the opposition can be made to adhere to the same painting suggests that they might be false distinctions' (p. 146).

Chapter Six

- 1 Damisch attributes this work to Giotto. Given the lack of corroborating evidence, the attribution of works in the Upper Church at Assisi is, to say the very least, problematic. The argument remains; however, regardless of the accuracy of any attribution.
- 2 The notion of perspectival construction as 'a systematic abstraction from the structure of this psychophysiological space' is put forward by Panofsky in *Perspective as Symbolic Form* (1991, p. 30). Challenging Panofsky's position, Elkins contends that 'all Panofsky's descriptive terms for artistic spaces from ancient to Renaissance art are themselves modern' (1994, p. 22). Elkins argues: 'The Renaissance had things the other way around in regard to space and that artists and writers thought first of objects and second of what we call perspective space or fictive space. In a phrase, the Renaissance notion is "object oriented" and the modern concept "space oriented"' (p. 15). One might accept Elkins corrective to Panofsky while acknowledging that while Alberti does not talk about space in a contemporary way, he is nevertheless undoubtedly aware of the *movement of bodies in space* relative to an observer. Thus Alberti argues: 'In the first place, when we look at a thing, we see it as an object which occupies a space' (1972, p. 67). Even if Renaissance painters lacked a 'concept' of systematic space, pictorial space arises from the depiction of a foreshortened architecture conceived as a container for bodies in space.
- 3 Podro, for instance, has pointed out the subtle registering of the direction of our arrival by Giotto's *St Francis Appearing to the Brethren at Arles* (fig. 80), achieved through the shifting of symmetry to create the effect of an oblique view (1998, pp. 61-64). Podro does not comment upon the corresponding ambiguity in St Francis's positioning in space, whereby he 'floats' forward in a way that he appears to address *us* as well as the Brethren. For a consideration of a similar ambiguity in the relationship between implied space and painted surface, see Laura Jacobus on Giotto's *Annunciation* in the Arena Chapel (1999, 2008) (fig. 81, 82).
- 4 These clouds are the source of the miraculous summer snowfall, whereby Pope Liberius is able to outline the groundplan of the church - see Frederick Hartt (1987, p. 184).
- 5 John White notes how the 'relative size [of Christ and the Virgin], the absolute circular glory which surround them, and the horizontal bar of cloud that closes in the spatial box below, all emphasize the flatness of the panel which is so forcefully attacked in its lower half' (1972, p. 143).
- 6 The comparison with a genuinely *trompe l'oeil* ceiling painting is telling. Andrea Pozzo's *Transmission of the Divine Spirit* (fig. 83) utilizes a marble disc, inset into the floor, to designate the exact spot for the beholder to stand in order for the illusion to fully cohere. Unlike the Correggio, the illusory impact, dependent upon such a precise determining of the viewer position, comes to the fore. The interstitial space between realms has become far more elaborate, the perspectival architectural frame extending upwards into the celestial space. Here, the illusory architecture and heavenly realm, a fanciful extension of the real architecture, is first and foremost a decorative element. If Correggio allies the metaphysical distinction between painted space and real architecture to the work's religious content, Pozzo obliterates such a separation in a virtuoso display of *trompe l'oeil* painting - the spectacle offered taking precedence over the work's integration into the religious life of the church.
In terms of convincing illusions, ceiling paintings benefit from their distance from the viewer. Puttfarken quotes the German physicist Helmholtz, who notes that 'Compared with a large picture at a greater distance, all those elements which depend on binocular vision and on the movement of the body are less operative, because in very distant objects the differences between the images of the two eyes, or between the aspect from adjacent points of view, seem less' (Helmholtz 1962, pp. 254-255: cited in Puttfarken 2000, p. 22).
- 7 Although, as Damisch notes, 'it must be said that in some compositions the banks of cloud are forcefully drawn and take on an altogether solid, material appearance' (2002, p. 15).
- 8 Correggio's ceiling paintings have much in common with many of the defining features of such a relationship, as listed in Chapter Four (pp. 80-82). The precursor to Correggio's solution of 'opening' up the very fabric of a building is Mantegna's *Camera degli Sposi* (fig. 8). As Shearman insists upon, this earlier model is in fact not a dome, but a fictitious oculus painted on the virtually flat central section of the vaulted ceiling (1992, p. 168). It is primarily an illusory device, playful in intent: a spectacle, rather than a work that allies its solution to any religious content. And yet the association of domes and vaulted spaces with the celestial has a much longer tradition, and it is not at all surprising that Mantegna's model is later adapted to specifically religious use. See, for instance, Shearman (1992, ch. IV). Ceiling paintings, in their emphasis on verticality, have the obvious advantage in that the pictorial depth facilitated by perspective can open up to the heavens, the infinite and undefined.
- 9 I am dubious about Bryson's claim to fix this position at roughly 'the height indicated by the Madonna's extended right hand' (1983, p. 108). While clearly painted from a higher viewpoint, the lack of orthogonals prevents us from locating this second 'vanishing point' (if such a term is, indeed, appropriate) with any accuracy.



Fig. 80 Giotto: *St Francis Appearing to the Brethren at Arles* (1315-20), Bardi Chapel, S. Croce, Florence.



Figs. 81, 82 Giotto: *Annunciation* (c. 1305-1310), Arena Chapel, Padua.



Fig. 83 Andrea Pozzo: *Transmission of the Divine Spirit* (1691-94), S. Ignazio, Rome.

- 10 A point forcefully made by Elkins (1994, pp. 241-242). In fact, Jane Andrews Aiken (1998) proposes that rather than using Alberti's 'pavement-based' system, computer-generated measurements of Masaccio's fresco 'are strongly suggestive of the probability that Masaccio and Brunelleschi constructed the apparent diminution of the vault ribs using a relatively simple projection technique dependent on the surface grid and directly derived from the astrolabe' (p. 100). J.V. Field has also established that in Masaccio's fresco 'the compass sweeps that define the edges of the ribs do not reach as far as the mouldings' (2005, p. 48); echoing Aiken, Field suggests that the absence of end points to these arcs 'is a clear indication that the positions of the ribs were not found by making a pseudo-pavement on the level of the base of the vault' (p. 48). This does not, however, negate the argument about the occlusion of the horizon.
- 11 While this centric point is difficult to locate in reproductions (primarily because of the comparative shortness of the orthogonal), it can clearly be established in the space of the church, despite the considerable damage the fresco suffered during the Second World War bombing of the church.
- 12 For a fascinating discussion of the theme of the Virgin's Assumption, see Goffen (1986, pp. 91-106). Goffen notes that 'fourteenth-century texts put considerable emphasis on the exaltation in heaven of Mary's body', while 'a fifteenth-century Venetian life of the Virgin describes the physical reality of the assumption of her incorruptible, immaculate body into heaven' (p. 92). This has significance for her intercessory role, as Mary's 'bodily presence in heaven assures a more valid mediation for the faithful' (p. 98).
- 13 There is some doubt about the work's original height, as the painting has been moved – see J. V. Field (2005, p. 225). From my own observations (admittedly at a distance from the work, and hence also reliant on reproductions) I disagree with White's contention that the column capitals conform to a higher position than those of the base – see White (1972, p. 196). However, if this were to be the case, it would merely support the argument made with respect to Mantegna's *Assumption*.
- 14 One might most readily think of the anamorphic skull in Holbein's *The Ambassadors*; however, for less well-known (and less extreme) examples, see Christian Müller's 'It Is the Viewpoint That Matters: Observations on the Illusionistic Effect of Early Works by Hans Holbein' (2001)
- 15 The startling impact that the painting had on Fyodor Dostoyevsky is well recorded. This is a painting that could make one lose one's faith. The painting's role in Dostoyevsky's *The Idiot* is discussed in Erika Michael's 'The Legacy of Holbein's Gedankenreichtum' (2001) and Julia Kristeva's 'Holbein's Dead Christ' (1989).
- 16 Kristeva notes that 'the two women who appear in the top left-hand corner of Mantegna's painting introduce the grief and compassion that Holbein precisely puts aside by banishing them from sight or else creating them with no other mediator than the invisible appeal to our all-too-human identification with the dead Son' (1989, p. 117).



Fig. 84 Piero della Francesca: *The Flagellation of Christ* (c. 1460), Galleria Nazionale delle Marche, Urbino.

- 17 See, for instance, Müller (2001). The effect is somewhat lessened by the work's frame, which is not original.
- 18 The oblique viewpoint is consistent with the possibility that the work once occupied a side chapel, and was thus approached from the left. Kristeva notes that: 'Among the various interpretations given by critics, one stands out and seems today the most plausible one. The painting would have been done for a predella that remained independent and was to occupy a raised position with respect to visitors filing down frontally, from the side and the left (for instance, from the church's central nave towards the southern aisle). In the Upper Rhine region there are churches that contain funerary recesses where *sculptured* Christly bodies are displayed. Might Holbein's work be a painterly transportation of such recumbent statues?' (1989, p. 111)
- 19 John Lechte has argued that Kristeva's realism is one that allows the symbolic to emerge: 'it is only a fiction – and yet it places us in touch with the real' (1990, p. 348). He notes that the semiotic 'critique of realism had often been made according to a hermeneutics which placed emphasis on the very idea that every framework or medium was the basis of an interpretation. Reality would never be reached, in short, because it would always be mediated' (p. 348). He contrasts this with Kristeva's approach 'of pointing out that a vision of reality (call it the original object) is an integral part of a viable subjectivity, one which keeps extreme melancholia at bay. The vision of reality constitutes the basis of the capacity of identification as such' (p. 348). With Holbein, this includes an invitation 'to become one with Christ's suffering' (p. 349). I would argue that such an identification is consistent with the role I assign imagination.
- 20 Although this does not in itself explain the missing section of the tomb's frame, which is also absent from the top of the recess.
- 21 Piero's *The Flagellation of Christ* (fig. 84) is another work that divides into two zones, although here the perspective is famously consistent, evidenced by the numerous reconstructions. Despite the unusually consistent perspective, the painted architecture structures the same separation of temporal and spatial realms we have noted in relation to the depiction of the supernatural, a separation that has led to considerable speculation as to the relationship between the three foreground figures and the scene of the Flagellation itself. Christ's body is unmarked, and the painting depicts the moment just prior to the first stroke. Both flagellators are poised, ready to strike – a suspended moment captured for perpetuity. The mystical light gives the Flagellation scene a dreamlike quality, removed from time, as if (perhaps) seen through the eyes of the angelic looking foreground figure.
- 22 Architectural thresholds are a recurrent theme of paintings depicting the Annunciation (scenes which, by definition, *exclude* the presence of an onlooker). Echoing a distinction made by Wollheim (1987, ch. VI), I want to contrast the metaphoric content of such works with the metaphorizing of part of the work I have described with respect to Vermeer's *Girl Asleep*. An intimate scaling of architecture to figure is

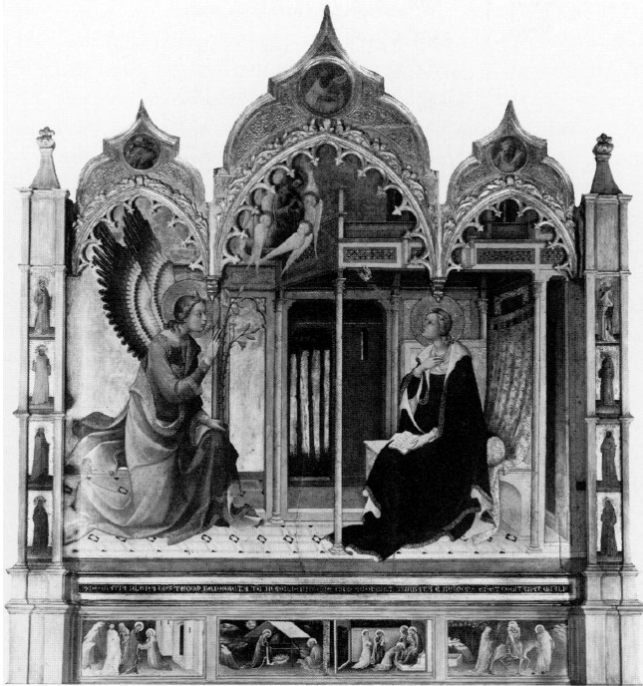

Fig. 85 Lorenzo Monaco: *Annunciation* (c. 1420-24), Santa Trinita Church, Florence.



Fig. 86 Petrus Christus: *Annunciation* (c. 1450), The Metropolitan Museum of Art, New York.



Fig. 87 Domenico Veneziano: *Annunciation* (c. 1445-47), Fitzwilliam Museum, Cambridge.



Fig. 88 Pieter de Hooch: *A Woman Delousing a Child's Hair* (c. 1658-60), Rijksmuseum, Amsterdam.

apparent in works such as Lorenzo Monaco's *Annunciation* (fig. 85), making Annunciations particularly suitable works for representing metaphoric content. As Blum notes: 'Mary's womb, the fabulous vessel that was able to carry "the One whom the heavens cannot contain", had long been an object of veneration in song, exegesis, and prayer. Her body was likened to all forms of enclosed architecture – a temple, a tent, a church, a castle, to name only a few – and prefigured in any number of images from the Old Testament' (1992, p. 55). Petrus Christus's New York *Annunciation* (fig. 86) is an example of a work that paints just such a metaphor. Domenico Veneziano's *Annunciation*, painted for the predella of his Saint Lucy Altarpiece (fig. 87), uses perspectival means to draw our attention to the door at the rear of the *hortus conclusus*. Both locked door and garden are symbolic of Mary's virginity. Here the 'strong pull of linear perspective' is allied to the metaphoric content; Veneziano emphasizes this pull by aligning Gabriel's posture with the orthogonals, the path 'ingeniously aligned with the angel's back, raised arm and lily' (Penny 1990, p. 34). Again, architecture dramatizes metaphoric content, but primarily through symbolic means.

23 Dogs and children were a common domestic feature of Dutch genre painting, noticeably absent in Vermeer's work. De Hooch uses similar devices in a number of paintings. In *A Woman Delousing a Child's Hair* (fig. 88) a dog sits at an internal threshold, transfixed by the light which streams in from a half-door which opens onto a garden. The dog mediates between the domestic world of the woman and child and the external world represented by the penetrating sunlight. The intimacy of the former is enhanced by its inherent tactility, revealed in the tender act of grooming and the softness of the contained cupboard bed. The dog belongs to this realm, but also craves the outside world to which it is denied by the closed lower section of the door. *Woman Lacing her Bodice Beside a Cradle* (fig. 58), referred to earlier, further explores the theme. The smiling woman has just finished breast-feeding the baby, while a small dog – whose body is directed towards an open doorway – glances back at the cradle. The dog's posture reveals its dualistic role within the spatial arrangement. The device is reinforced by a young child, who stands in the brightly lit foyer silhouetted against an open half-door, through which she stares at the world beyond.

In *Soldier and Laughing Girl* (fig. 25) Vermeer clearly depicts two opposed spheres conceived in terms of the interior and exterior realms of the woman and man. The man has his back to us, and is pushed hard up against the implied picture plane. He is clearly an outsider: he still wears his hat, which is silhouetted against an open window. His body language reveals his awkwardness within the

- domestic realm of the woman, who, in contrast, appears totally at ease. Edward Snow remarks upon the metaphor of the closed and concealed hand of the man, and the open and revealed hand of the woman (1994, p. 84).
- 24 While some of these scenes are deliberately ambiguous, others – such as *Woman Drinking with Soldiers* (fig. 89) – clearly depict brothel scenes. If, as Peter C. Sutton suggests, ‘the supposition that more than a glass of wine will be shared ... stems partly from the importuning old woman, reminiscent of the procuress types in earlier works’ (1984, p. 217), then it also arguably stems from the invitation of the open door, which offers a view through a lobby toward a room which the merry makers will no doubt retire to.
- 25 One might note a similar dynamic in twentieth century works by Vilhelm Hammershøi (fig. 90) or Edward Hopper (fig. 91). For a discussion of ‘Hoppers’s Melancholic Gaze’ see Iversen (2004). With Hammershøi’s works, his wife, Ida, is repeatedly painted with her back facing the implied viewer, juxtaposed with a view through an open doorway into an empty space. As Felix Krämer notes, we are thus ‘denied the clues to a sitter’s emotional state’ (2008, p. 19), or whether our presence has been registered (p. 13). Echoing Krämer, I believe we are invited to project onto such oddly unsettling spaces, in a way that is analogous to the shared reverie of Vermeer’s *Girl Asleep*.

Chapter Seven

- 1 In other words, it is not necessary to hold a ‘concept’ of the notion of projection in order to experience or construct such a space; given that projection is an unconscious and primitive mental functioning, an expulsive defence mechanism originating from early childhood, this should hopefully be self-evident. See, for instance, Melanie Klein (1997).
- 2 Wollheim’s theory is mapped out in ‘The Sheep and the Ceremony’ (1993, pp. 1-21), and developed in *Painting as an Art* (1987, pp. 80-87) and ‘Correspondence, Projective Properties, and Expression’ (1991, pp. 51-66).
- 3 Wollheim was rare amongst analytic philosophers in regarding psychoanalytic theory as having something positive to contribute to both the philosophy of mind and the philosophy of art. Wollheim’s commitment to psychoanalysis underpins much of his theoretical writing on art.
- 4 As Wollheim notes in *Painting as an Art*, this is not to suggest that ‘expressive perception just is the metaphorical application of psychological predicates to the world’ (1987, p. 85).
- 5 Budd recalls that in a discussion that followed Budd’s paper at a conference on Wollheim’s aesthetics in Utrecht, 1997, ‘Wollheim – I believe rightly – dismissed this position as absurd, implying that (despite the appearances) he had never embraced it’ (2001, p. 110, n. 7).
- 6 Unlike the view of Ryle in *The Concept of Mind* (2000), Wollheim argues that mental dispositions have psychological reality (1999, pp. 3-4).
- 7 See also Wollheim’s *On the Emotions* (1999, p. 3).
- 8 As Wollheim argues, ‘the fact remains that projection itself must always remain less than perspicuous’ (1987, p. 85). Little more can be said.
- 9 See for instance ‘Notes on Some Schizoid Mechanisms’ in Klein (1997, pp. 1-24); Bion (1984, pp. 90-94).
- 10 See, for instance, Hans Leowald (1980) and Forster and Carveth (1999).
- 11 With the possible exception of Holbein’s *Dead Christ*.

Conclusion

- 1 I am certainly not the only artist to have been challenged by the sheer complexity of ideas in these earlier paintings, or to have found in such works a *conceptual* structuring with relevance to a contemporary sculptural or film practice. This is very different to the essentially ‘pictorial’ use of Renaissance paintings in some of Bill Viola’s recent video art. As has been widely reported, sculptor Richard Serra’s ‘big epiphany as an artist’ came with the viewing of Velázquez’s *Las Meninas* for the first time, while still a young painter: ‘I looked at it for a long time before it hit me that I was an extension of the painting. This was incredible to me. A real revelation. I had not seen anything like it before and it made me think about art, and about what I was doing, in a radically different way’ (cited in O’Hagan 2008). For Serra, this was a work that broke through the closed frame of painting to directly implicate the spectator: a sense of presence that persisted despite the seemingly contradictory interpretations the work posited. According to Jennifer Roberts, Jacopo Pontormo’s *The Descent from the Cross* played an analogous role in Serra’s friend Robert Smithson’s evolution as an artist, again from painter to artist producing three-dimensional work (Roberts 2004, pp. 36-39). Roberts suggests that Smithson was fascinated by ‘what we might call the *dispositional temporality* of Pontormo’s painting’ (p. 39), stimulating reflections on the



Fig. 89 Pieter de Hooch: *Woman Drinking with Soldiers* (1658), Musée du Louvre, Paris.

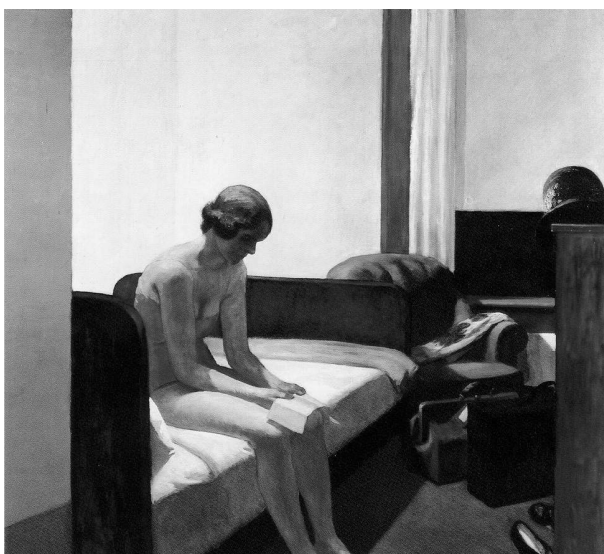

Fig. 90 Edward Hopper: *Hotel Room* (1931), Museo Thyssen-Bornemisza, Madrid.



Fig. 91 Vilhelm Hammershøi: *Strandgade 30* (1901), Private Collection.

containment of time that culminated in a series of 'gyrostatic' structures which Smithson describes thus: 'All rotational progressions are brought to a static state. The rotation is non-dynamical, inactive, and stopped. Movement is impossible. Temporal duration is excluded ...' (cited Roberts 2004, p. 39, from the press-release for his second-one man exhibition at the Dwan gallery in 1968).

2 For convenience, I use the term Minimalism despite the reluctance of such artists to be described thus.
3 Fried distinguishes his position on opticality from Greenberg's in 'An Introduction to My Art Criticism',
in *Art and Objecthood* (1998, pp. 19-23).

4 In his introduction to *Absorption and Theatricality* Fried writes:

[T]he concept of theatricality is crucial to my interpretation of French painting and criticism in the age of Diderot, and in general the reader who is familiar with my essays on abstract art will be struck by certain parallels between ideas developed in those essays and in this book. Here too I want to assure the reader that I am aware of those parallels, which have their justification in the fact that the issue of the relationship between painting (or sculpture) and beholder has remained a matter of vital if often submerged importance to the present day. (1980, p. 5)

More recently Fried has extended his scope to a consideration of Barthes's *Punctum* (Fried 2005) and the contemporary photography of Jeff Wall (Fried 2007).

5 Bishop defines 'four modalities of experience that [installation] art structures for the viewer' (2005, p. 8):
(i) 'Dream Space' (ch. 1), which puts forward 'a model of the subject as psychological, or more accurately psychoanalytical' (p. 10), where the viewer is frequently conceived as an 'actor' or 'protagonist' in a physically immersive 'scene' that transports us into a different fictional reality (pp. 14-16, 47); (ii) 'Heightened Perception' (ch. 2), which describes phenomenologically orientated installations; (iii) 'Mimetic Engulfment' (ch. 3), characterized by 'libidinal withdrawal and subjective disintegration' (p. 10), a 'dissolution' of the self (p. 82); (iv) 'Activated Spectatorship' (ch. 4), a modality 'that posits the activated viewer of installation art as a political subject' (p. 10). Now, while one might quibble about aspects of such categorization, Bishop offers an account that while poststructuralist is distinguished by its emphasis on 'experience' rather than 'interpretation'. This 'experiential' emphasis (often informed by notions of the performative) is echoed by other recent art criticism that questions conceptualism's 'immutable antinomies of thought and experience' – see Kraynak (2003, p. 14). While I agree with Bishop's claim that much of the art from the late 1960s onwards proposed the notion of the 'decentred subject' (2005, p. 11), I am less convinced by her poststructuralist characterisation of the viewer of Renaissance perspective – see earlier comments with respect to Cartesian perspective.

6 As Bishop notes, 'the phrase "light and space" was coined to characterise the predilection of these artists for empty interiors in which the viewer's perception of contingent sensory phenomena (sunlight, sound, temperature) became the content of the work' (2005, p. 56).

7 With Asher, this foregrounding of the phenomenology of the work's perception is allied to a situational aesthetic Buchloh describes as insisting 'on a critical refusal to provide an existing apparatus with legitimizing aesthetic information' (editor's note in Asher 1983, p. VII).

8 Turrell notes of the *City of Arhirit* installation at the Stedelijk that 'people got down on their hands and knees and crawled through it because they experienced intense disequilibrium' (2002, p. 124).

9 Some of Turrell's more recent work, such as *Tall Glass* (2007), makes this reference to painting, to my mind, rather too explicit.

10 Catherine Elwes argues that video monitors 'problematize the spectator position' in a way that much contemporary projected work fails to do (2005, p. 155). Elwes claims that the critical distance established by monitors is 'replaced by the spectacular, immersive experience of cinema' (p. 151).

11 As we have seen, Masaccio's *Trinity* implies three coexistent spatiotemporal realms.

12 This activation of the space of the viewer is taken even further in McCall's *Long Film for Four Projectors* (1974), where the work directly engages its surrounding architecture. Four diagonal projections of a shifting tilted line are projected into the room's corners, creating four wedges of light that cross over each other.

References and Bibliography

- Ackerman, J. S. (1991a) Alberti's Light. In Ackerman, J. S. *Distance Points: Essays in Theory and Renaissance Art and Architecture*: 59-96 (Cambridge, MA and London: MIT Press).
- _____. (1991b) Leonardo's Eye. In Ackerman, J. S. *Distance Points: Essays in Theory and Renaissance Art and Architecture*: 97-150 (Cambridge, MA and London: MIT Press).
- Alberro, A. and B. Stimson (eds.). (2000) *Conceptual Art: A Critical Anthology* (Cambridge, MA: MIT Press).
- Alberti, L. B. (1966) *On Painting*. Translated by John R. Spencer (New Haven and London: Yale University Press).
- _____. (1972) *On Painting and On Sculpture: The Latin Texts of De Pictura and De Statua edited with English Translations, Introduction and Notes*. Edited and translated by Cecil Grayson (London: Phaidon).
- Alpers, S. (1983) Interpretation without Representation, or, The Viewing of *Las Meninas*. *Representations*, no. 1, February: 30-42.
- _____. (1989) *The Art of Describing: Dutch Art in the Seventeenth Century* (London: Pelican Books).
- _____. (2001) Viewing Making Painting. In van Gerwen, R. (ed.) *Richard Wollheim on the Art of Painting: Art as Representation and Expression*: 171-176 (Cambridge: Cambridge University Press).
- _____. (2005) *The Vexations of Art: Velázquez and Others* (New Haven and London: Yale University Press).
- Andrews Aiken, J. (1998) The Perspective Construction of Masaccio's *Trinity* Fresco and Medieval Astronomical Graphics. In Goffen, R. (ed.) *Masaccio's Trinity*: 90-107 (Cambridge: Cambridge University Press).
- Arasse, D. (1994) *Vermeer: Faith in Painting*. Translated by Terry Grabar (New Jersey: Princeton University Press).
- Arnheim, R. (1965) *Art and Visual Perception: A Psychology of the Creative Eye* (Berkeley: University of California Press).
- Asher, M. (1983) *Michael Asher: Writings 1973-1983 on Works 1969-1979*. Written in collaboration with and edited by Benjamin H. D. Buchloh (Halifax, Nova Scotia and Los Angeles: The Press of the Nova Scotia College of Art and Design, and The Museum of Contemporary Art Los Angeles).
- Bal, M. (1998) Seeing Signs: The Use of Semiotics for the Understanding of Visual Art. In Cheetham M. A., M. A. Holly and K. Moxey (eds.) *The Subjects of Art History: Historical Objects in Contemporary Perspective*: 74-93 (Cambridge: Cambridge University Press).
- _____. (2001) *Looking In: The Art of Viewing*. Introduction by Norman Bryson (Amsterdam: G&B Arts International).
- Baldwin, T. (2004) Introduction. In Merleau-Ponty, M. *The World of Perception*: 1-33. Translated by Oliver Davis (London and New York: Routledge).
- Barthes, R. (1977) The Death of the Author. In *Image-Music-Text*: 142-148. Essays selected and translated by Stephen Heath (New York: Hill and Wang).
- _____. (1989) The Reality Effect. In *The Rustle of Language*: 141-149. Translated by Richard Howard (Berkeley: University of California Press).
- _____. (2001) *Camera Lucida: Reflections on Photography*. Translated by Richard Howard (London: Vintage).
- Batchelor, D. (1997) *Minimalism* (London: Tate Gallery Publishing).
- Baxandall, M. (1985) *Patterns of Intention* (New Haven and London: Yale University Press).
- _____. (1988) *Painting and Experience in Fifteenth Century Italy* (Oxford: Oxford University Press).
- Benveniste, E. (1971) *Problems in General Linguistics*. Translated by Mary Elizabeth Meek (Coral Gables, Florida: University of Miami Press).
- Bion, W. R. (1984) *Learning from experience* (London: Maresfield).
- Birnbaum, D. (2002) Eyes and Notes on the Sun. In *James Turrell: The Other Horizon*: 226-231. Edited by Peter Noever (Vienna and Ostfildern-Ruit, Germany: MAK und Hatje Cantz Verlag).
- Bishop, C. (2005) *Installation Art: A Critical History* (London: Tate Publishing).

- Blankert, A. (1981) *Vermeer: Every Painting*. Translated by Lucia Wildt (New York: Rizzoli).
- Blum, S. N. (1992) Hans Memling's *Annunciation with Angelic Attendants*. *Metropolitan Museum Journal*, vol. 27: 43-58.
- Bonnefoy, Y. (1998) Time and Timeless in Quattrocento Painting. In Goffen, R. (ed.) *Masaccio's Trinity*: 108-118 (Cambridge: Cambridge University Press).
- Brown, J. (1978) *Images and Ideas in Seventeenth-Century Spanish Painting* (New Jersey: Princeton University Press).
- _____. (1986) *Velázquez: Painter and Courtier* (New Haven and London: Yale University Press).
- Bryson, N. (1983) *Vision and Painting: The Logic of the Gaze* (London: The Macmillan Press).
- _____. (1988) The Gaze in the Expanded Field. In Foster, H. (ed.) *Vision and Visuality*: 87-113 (Seattle: Bay Press).
- Buchloh, B. (2000) Moments of History in the Work of Dan Graham. In *Dan Graham: Articles (1978)* 211-216 (Eindhoven: van Abbemuseum). Reprinted in Alberro, A. and B. Stimson (eds.) *Conceptual Art: A Critical Anthology*: 376-388 (Cambridge, MA: MIT Press).
- Budd, M. (1992) On Looking at a Picture. In Hopkins, J. and A. Savile (eds.) *Psychoanalysis, Mind and Art: Perspectives on Richard Wollheim*: 259-280 (Oxford: Blackwell).
- _____. (2001) Wollheim on Correspondence. In van Gerwen, R. (ed.) *Richard Wollheim on the Art of Painting: Art as Representation and Expression*: 101-111 (Cambridge: Cambridge University Press).
- _____. (2004) How Pictures Look. In Knowles, D. and J. Skorupski (eds.) *Virtue and Taste (1993)*: 154-75 (Oxford: Blackwell). Reprinted in Lamarque, P. and S. H. Olsen (eds.) *Aesthetics and the Philosophy of Art: The Analytic Tradition*: 383-395 (Malden, Oxford and Carlton, Australia: Blackwell Publishing).
- Bynum, C. Walker. (1992) *Fragmentation and Redemption: Essays on Gender and the Human Body in Medieval Religion* (New York: Zone Books).
- _____. (2002) The Blood of Christ in the Later Middle Ages. *Church History*, vol. 71, no. 4: 685-714.
- Carveth, D. L. (1998) Freud's Flawed Philosophy of Religion: A Reply to Rempel. *Canadian Journal of Psychoanalysis/Revue Canadienne de Psychanalyse* 6, 1 (Spring): 141-147. Available from: <http://www.yorku.ca/dcarveth/flawed.htm> [Accessed 10 November 2008].
- Châtelet, A. with J. Thuillier (1964) *French Painting from Le Nain to Fragonard*. Translated by J. Emmons (Geneva).
- Cole, G. (2006) 'Wavering Between Two Worlds': The Doorway in Seventeenth-Century Dutch Genre Painting. In *Philament Issue 9: On 'Liminal'*, December 2006. Available from: http://www.arts.usyd.edu.au/publications/philament/issue9_contents.htm [Accessed 12 June 2008].
- Carman, T. and M. B. N. Hansen (2005) Introduction. In Carman, T. and M. B. N. Hansen (eds.) *The Cambridge Companion to Merleau-Ponty*: 1-25 (Cambridge: Cambridge University Press).
- Casey, E. S. (1981) Sartre on Imagination. In Schlipp, P. A. (ed.) *The Philosophy of Jean-Paul Sartre*: 139-166. *The Library of Living Philosophers*, vol. 16 (La Salle: Open Court).
- Crary, J. (1988) Modernizing Vision. In Foster, H. (ed.) *Vision and Visuality*: 29-49 (Seattle: Bay Press).
- Crowther, P. (1993a) *Art and Embodiment: From Aesthetics to Self-Consciousness* (Oxford: Clarendon Press).
- _____. (1993b) *Critical Aesthetics and Postmodernism* (Oxford: Oxford University Press).
- _____. (2001) Twofoldness: From Transcendental Imagination to Pictorial Art. In van Gerwen, R. (ed.) *Richard Wollheim on the Art of Painting: Art as Representation and Expression*: 85-98 (Cambridge: Cambridge University Press).
- _____. (2002) *The Transhistorical Image: Philosophizing Art and its History* (Cambridge: Cambridge University Press).
- _____. (2008) Pictorial Space and the Possibility of Art. *British Journal of Aesthetics*, vol. 48, no. 2: 175-192.
- Damisch, H. (1994) *The Origin of Perspective*. Translated by J. Goodman (Cambridge, MA and London: The MIT Press).
- _____. (2002) *A Theory of /Cloud/: Toward a History of Painting*. Translated by Janet Lloyd (Stanford, California: Stanford University Press).
- Damisch, H. and S. Bann (2005) Hubert Damisch and Stephen Bann: A Conversation. *Oxford Art Journal*, vol. 28, no. 2: 155-181.
- Derrida, J. (1987) *The Truth in painting*. Translated by Geoff Bennington and Ian McLeod (Chicago: University of Chicago Press).
- Druro, P. (ed.). (1996) *The Rhetoric of the Frame: Essays on the Boundaries of the Artwork* (Cambridge: Cambridge University Press).
- Edgerton, S. (1976) *The Renaissance Rediscovery of Linear Perspective* (New York, Evanston, San Francisco and London: Icon Editions, Harper and Row).
- _____. (1991) *The Heritage of Giotto's Geometry: Art and Science on the Eve of the Scientific Revolution*

- (New York: Cornell University Press).
- Ehrenzweig, A. (2000) *The Hidden Order of Art: a Study in the Psychology of Artistic Perception* (London: Phoenix).
- Elkins, J. (1994) *The Poetics of Perspective* (Ithaca and London: Cornell University Press).
- _____. (1999) *Why are our Pictures Puzzles? On the Modern Origins of Pictorial Complexity* (London and New York: Routledge).
- Elwes, C. (2005) *Video Art: a Guided Tour*. Foreword by Shirin Neshat (London and New York: I B Tauris).
- Evans, G. (1982) *The Varieties of Reference*. Edited by John Mc Dowell (Oxford: Oxford University Press).
- Field, J. V. (2005) *Piero della Francesca: A Mathematician's Art* (New Haven and London: Yale University Press).
- Forster, S. E. and D. L. Carveth. (1999) Christianity: A Kleinian Perspective. *Canadian Journal of Psychoanalysis/Revue Canadienne de Psychanalyse* 7, 2 (Fall): 187-218. Available from: <http://www.yorku.ca/dcarveth/klein.htm#gold> [Accessed 10 November 2008].
- Foucault, M. (1974) *The Order of Things: An Archaeology of the Human Sciences*. English addition paperback (London: Tavistock Publications).
- Freud, S. (1966-1974) *The Standard Edition of the Complete Psychological Works of Sigmund Freud*. Translated and edited by James Strachey, in collaboration with Anna Freud assisted by ... (others), 24 volumes (London: Hogarth Press and the Institute of Psycho-Analysis).
- Fried, M. (1988) *Absorption and Theatricality: Painting and Beholder in the Age of Diderot* (Chicago: University of Chicago Press).
- _____. (1998) *Art and Objecthood: Essays and Reviews* (Chicago and London: University of Chicago Press).
- _____. (2005) Barthes's Punctum. *Critical Inquiry* 31 (Spring): 539-574.
- _____. (2007) Jeff Wall, Wittgenstein, and the Everyday. *Critical Inquiry* 33 (Spring): 495-525.
- Friedberg, A. (2006) *The Virtual Window: From Alberti to Microsoft* (Cambridge, MA and London: MIT Press).
- Gaskell, I. (1990) *The Thyssen-Bornemisza Collection: Seventeenth-Century Dutch and Flemish Paintings* (London).
- Goffen, R. (1986) *Piety and Patronage in Renaissance Venice: Bellini, Titian and the Franciscans* (New Haven and London: Yale University Press).
- _____. (1989) *Giovanni Bellini* (New Haven and London: Yale University Press).
- _____. (1998a) Introduction: Masaccio's *Trinity* and the Early Renaissance. In Goffen, R. (ed.) *Masaccio's Trinity*: 1-32 (Cambridge: Cambridge University Press).
- _____. (1998b) Masaccio's *Trinity* and the Letter to Hebrews. In Goffen, R. (ed.) *Masaccio's Trinity*: 43-64 (Cambridge: Cambridge University Press).
- Gombrich, E. (1963) *Meditations on a Hobby Horse and Other Essays on the Theory of Art* (London: Phaidon Press).
- _____. (1977) *Art and Illusion: A Study in the Psychology of Pictorial Representation* (London: Phaidon Press).
- _____. (1982) *The Image and the Eye* (Oxford: Phaidon Press).
- Goodman, N. (1969) *Languages of Art: an approach to a theory of symbols* (London: Oxford University Press).
- Govan, M. and T. Bell (2004) *Dan Flavin: A Retrospective*. With an Essay by Bryndon E. Smith (New York: Dia Art Foundation).
- Gowing, L. (1997) *Vermeer* (London: Giles de la Mare Publishers Limited).
- Graham, D. (2003) Video in Relation to Architecture. In *Dan Graham: Public/Private* (Philadelphia: The Galleries at Moore). Available from: <http://www.thegalleriesatmoore.org/uploads/media/publications/downloads/DanGraham.pdf> [Accessed 11 January 2009].
- _____. (2005) Dan Graham Interview. Interviewed by Pietro Valle. *Artland* [online]. Available from: http://architettura.supereva.it/artland/200020515/index_en.htm [Accessed 15 January 2005].
- Greenberg, C. (1982) Modernist Painting. In (1965) *Art and Literature* no. 4, spring: 193-201. Reprinted in *Modern Art and Modernism: A Critical Anthology*: 5-10 (London: The Open University).
- Gregory, R. L. (1970) *The Intelligent Eye* (New York: McGraw-Hill).
- Grootenboer, H. (2005) *The Rhetoric of Perspective: Realism and Illusionism in Seventeenth-Century Dutch Still-Life Painting* (Chicago and London: University of Chicago Press).
- Hamburger, J. F. (1990) *Nuns as Artists: The Visual Culture of a Medieval Convent* (New Haven: Yale University Press).
- _____. (1998) *The Visual and the Visionary: Art and Female Spirituality in Late Medieval Germany* (New York: Zone Books).
- Hartt, F. (1987) *History of Italian Renaissance Art: Painting · Sculpture · Architecture* (London: Thames and Hudson).

- Hegel, G. F. W. (1975) *Aesthetics: Lectures on Fine Arts*. Translated by T. M. Knox, 2 vols. (Oxford: Clarendon Press).
- Helmholtz, H. von (1962) *Popular Scientific Lectures* (New York).
- Hertel, C. (1996) *Vermeer: Reception and Interpretation* (Cambridge, New York and Melbourne: Cambridge University Press).
- Hinshelwood, R. D. (1991) *A Dictionary of Kleinian thought* (London: Free Association Books).
- Hollander, M. (2002) *An Entrance for the Eyes: Space and Meaning in Seventeenth-Century Dutch Art* (Berkeley: University of California Press).
- Hopkins, J. and A. Savile (eds.). (1992) *Psychoanalysis, Mind and Art: Perspectives on Richard Wollheim* (Oxford: Blackwell).
- Hopkins, R. (1997) Review of *Understanding Pictures* by Dominic Lopes. *British Journal of Aesthetics*, vol. 37, no. 3: 283-286.
- _____. (1998) *Picture, Image and Experience* (Cambridge: Cambridge University Press).
- _____. (2001) The Spectator in the Picture. In van Gerwen, R. (ed.) *Richard Wollheim on the Art of Painting: Art as Representation and Expression*: 215-231 (Cambridge: Cambridge University Press).
- _____. (2003) Sculpture and Space. In Kieran, M. and D. M. Lopes (eds.), *Imagination, Philosophy, and the Arts*: 272-290 (London and New York: Routledge).
- _____. (2004) Painting, Sculpture, Sight, and Touch. *British Journal of Aesthetics*, vol. 44, no. 2: 149-166.
- Humfrey, P. (1993) *The Altarpiece in Renaissance Venice* (New Haven and London: Yale University Press).
- Hyman, J. (2006) *The Objective Eye: Color, Form, and Reality in the Theory of Art* (Chicago and London: University of Chicago Press).
- Ingarden, R. (1973) *The Literary Work of Art*. Translated by George G. Grabowicz (Evanston, Illinois: Northwestern University Press).
- Iser, W. (1978) *The Act of Reading: A Theory of Aesthetic Response* (Baltimore: John Hopkins University Press).
- Iversen, M. (1993) *Alois Riegl: Art History and Theory* (Cambridge, MA and London: The MIT Press).
- _____. (2004) Hopper's Melancholic Gaze. In Wagstaff, S. (ed.) *Edward Hopper*: 52-65 (London: Tate Publishing).
- _____. (2005) The Discourse of Perspective in the Twentieth Century: Panofsky, Damisch, Lacan. *Oxford Art Journal* 28.2: 191-202.
- Jacobus, L. (1999) Giotto's *Annunciation* in the Arena Chapel, Padua. *Art Bulletin* 81/1: 93-107.
- _____. (1995) Giotto's Design of the Arena Chapel, Padua. *Apollo*, 142/406: 37-42.
- _____. (2008) *Giotto and the Arena Chapel: Art, Architecture and Experience (Studies in Medieval and Early Renaissance Art History)* (New York: Harvey Miller Publishers).
- Jay, M. (1988) Scopic Regimes of Modernity. In Foster, H. (ed.) *Vision and Visuality*: 2-23 (Seattle: Bay Press).
- _____. (1994) *The Denigration of Vision in Twentieth-Century French Thought* (Berkeley and Los Angeles California: University of California Press).
- Johnson, G. A. (1993) Introductions to Merleau-Ponty's Philosophy of Painting. In Johnson, G. A. (ed.) *The Merleau-Ponty Aesthetics Reader: Philosophy and Painting*. Michael B. Smith, Translation Editor: Part 1, 1-55 (Evanston, Illinois: Northwestern University Press).
- Joseph, B. W. (2005) Sparring with the Spectacle. In *Anthony McCall: The Solid Light Films and Related Works*: 35-77 (parts 1-5), 94-142 (parts 6-10) (Göttingen, Germany: Steidl).
- Kelly, S. D. (2001) The Non-conceptual Content of Perceptual Experience: Situation Dependence and Fineness of Grain. *Philosophy and Phenomenological Research*: vol. LXII, no. 3: 601-608.
- _____. (2005) Seeing Things in Merleau-Ponty. In Carman, T. and M. B. N. Hansen (eds.) *The Cambridge Companion to Merleau-Ponty*: 74-110 (Cambridge: Cambridge University Press).
- Kemp, M. (1990) *The Science of Art* (New Haven and London: Yale University Press).
- Kemp, W. (1985) Death at Work: On Constitutive Breaks in 19th Century Painting. *Representations* 10: 102-123.
- _____. (1994) Review of *Only Connect: Art and the Spectacle in the Italian Renaissance* by John Shearman. *The Art Bulletin*, vol. 76, no. 2: 364-367.
- _____. (1998) The Work of Art and Its Beholder: The Methodology of the Aesthetic of Reception. In Cheetham M. A., M. A. Holly and K. Moxey (eds.) *The Subjects of Art History: Historical Objects in Contemporary Perspective*: 180-196 (Cambridge: Cambridge University Press).
- _____. (1999) Introduction. In *The Group Portraiture of Holland*. Introduction by Wolfgang Kemp, translated by Evelyn M. Kain (Los Angeles, California: Getty Research Center for the History of Art and the Humanities).
- Klein, M. (1991) *The selected Melanie Klein*. Edited by Juliet Mitchell (Harmondsworth: Penguin).
- _____. (1997) *Envy and Gratitude: and Other Works, 1946-1963* (London: Vintage).

- _____. (1998) *Love, guilt and reparation: and Other Works 1921-1945* (London: Vintage).
- Krämer, F., Sato, N. and A-B. Fonsmark (2008) *Hammershøi* (London: Royal Academy of Arts).
- Krauss, R. (1981) *Passages in Modern Sculpture* (Cambridge, MA and London: MIT Press).
- _____. (1988) The Impulse to See. In Foster, H. (ed.) *Vision and Visuality: 51-78* (Seattle: Bay Press).
- _____. (1994) *The Optical Unconscious* (Cambridge, MA and London: MIT Press).
- Kraynak, J. (2003) Bruce Nauman's Words. In Nauman, B. *Please Pay Attention Please: Bruce Nauman's Words*. Edited by Janet Kraynak: 1-45 (Cambridge, MA and London: MIT Press).
- Kristeva, J. (1980) *Desire in Language: a Semiotic Approach to Literature and Art*. Edited by Leon S. Roudiez, translated by Thomas Gora, Alice Jardine, and Leon S. Roudiez (Oxford: Blackwell).
- _____. (1989) Holbein's Dead Christ. In Kristeva, J. *Black Sun: Depression and Melancholia*. Translated by Leon S. Roudiez: 105-138 (New York: Columbia University Press).
- Kubler, G. (1985) The 'Mirror' in *Las Meninas*. *The Art Bulletin*, vol. 67, no. 2: 316.
- Lacan, J. (1994) *The Four Fundamental Concepts of Psycho-Analysis*. Edited by Jacques-Alain Miller, translated by Alan Sheridan, introduction by David Macey (London: Penguin).
- Langer, S. K. (1953) *Feeling and Form* (New York: Scribners).
- Lavin, M. A. (1992) *Piero della Francesca* (London: Thames and Hudson).
- _____. (1990) *The Place of Narrative: Mural Decoration in Italian Churches, 431-1600* (Chicago and London: The University of Chicago Press).
- Lechte, J. (1990) Kristeva and Holbein, Artist of Melancholy. *British Journal of Aesthetics*, vol. 30, no. 4: 342-350.
- Leowald, H. (1980) *Papers on Psychoanalysis* (New Haven: Yale University Press).
- Levinson, J. (2001) Wollheim on Pictorial Representation. In van Gerwen, R. (ed.) *Richard Wollheim on the Art of Painting: Art as Representation and Expression: 28-38* (Cambridge: Cambridge University Press).
- _____. (2004) Intention and Interpretation in Literature. In Levinson, J. *The Pleasures of Aesthetics* (1996) 175-213 (Ithaca, New York: Cornell University Press). Reprinted in Lamarque, P. and S. H. Olsen (eds.) *Aesthetics and the Philosophy of Art: The Analytic Tradition: 200-222* (Malden, Oxford and Carlton, Australia: Blackwell Publishing).
- Lopes, D. M. (1992) Pictures, Styles and Purposes. *British Journal of Aesthetics*, vol. 32, no. 4: 330-341.
- _____. (1996) *Understanding Pictures* (Oxford: Oxford University Press).
- McFee, G. (2001) Wollheim on Expression (and Representation). In van Gerwen, R. (ed.) *Richard Wollheim on the Art of Painting: Art as Representation and Expression: 151-168* (Cambridge: Cambridge University Press).
- Marin, L. (1995) *To Destroy Painting*. Translated by Mette Hjort (Chicago and London: University of Chicago Press).
- _____. (2002) The Frame of Representation and Some of its Figures. In Marin, L. *On Representation: 352-372*. Translated by Catherine Porter (California: Stanford University Press).
- Martin, D. F. (1976) The Autonomy of Sculpture. *Journal of Aesthetics and Art Criticism*, vol. 34.
- Matravers, D. (1998) *Art and Emotion* (Oxford and New York: Oxford University Press).
- Maynard, P. (1994) Seeing Double. *Journal of Aesthetics and Art Criticism*, vol. 52, no. 2: 155-167.
- _____. (1996) Perspective Places. *Journal of Aesthetics and Art Criticism*, vol. 54, no. 1: 23-40.
- _____. (2005) *Drawing Distinctions: The Varieties of Graphic Expression* (Ithaca and London: Cornell University Press).
- Meissner, W. W. (1984) *Psychoanalysis and Religious Experience* (New Haven: Yale University Press).
- Merleau-Ponty, M. (1964) *The Primacy of Perception*. Translated by James Edie (Evanston, Illinois: Northwestern University Press).
- _____. (1968) *The Visible and the Invisible*. Edited by Claude Lefort, translated by Alfonso Lingis (Evanston, Illinois: Northwestern University Press).
- _____. (1993a) Cézanne's Doubt. In Johnson, G. A. (ed.) *The Merleau-Ponty Aesthetics Reader: Philosophy and Painting*. Michael B. Smith, Translation Editor: 59-75 (Evanston, Illinois: Northwestern University Press).
- _____. (1993b) Indirect Language and the Voices of Silence. In Johnson, G. A. (ed.) *The Merleau-Ponty Aesthetics Reader: Philosophy and Painting*. Michael B. Smith, Translation Editor: 76-120 (Evanston, Illinois: Northwestern University Press).
- _____. (1993c) Eye and Mind. In Johnson, G. A. (ed.) *The Merleau-Ponty Aesthetics Reader: Philosophy and Painting*. Michael B. Smith, Translation Editor: 121-149 (Evanston, Illinois: Northwestern University Press).
- _____. (2002) *Phenomenology of Perception*. Translated by Colin Smith (London and New York: Routledge).
- _____. (2004) *The World of Perception*. Translated by Oliver Davis (London and New York: Routledge).
- Michael, E. (2001) The Legacy of Holbein's Gedankenreichtum. In Roskill, M and J.O. Hand (eds.) *Hans Holbein: Paintings, Prints, and Reception: 227-246* (Washington: National Gallery of Art,

- distributed by New Haven and London: Yale University Press).
- Moffitt, J. (1983) Velázquez in the Alcázar Palace in 1656: The Meaning of the *Mise-en-scène* of *Las Meninas*. *Art History*, vol. 6, no. 3: 271-300.
- Moreland, J. M. (1998) For-itself and In-itself in Sartre and Merleau-Ponty. *Philosophy Today* 17 (1973): 311-318. Reprinted in Stewart, J. (ed.) *The Aesthetic Dialogue of Sartre and Merleau-Ponty*: 16-24 (Evanston, Illinois: Northwestern University Press).
- Müller, C. (2001) It Is the Viewpoint That Matters: Observations on the Illusionistic Effect of Early Works by Hans Holbein. In Roskill, M and J.O. Hand (eds.) *Hans Holbein: Paintings, Prints, and Reception*: 17-35 (Washington: National Gallery of Art, distributed by New Haven and London: Yale University Press).
- Mulvey, L. (2006) *Death 24x a Second: Stillness and the Moving Image* (London: Reaktion Books).
- Nanay, B. (2005) Is Twofoldness Necessary for Representational Seeing? *British Journal of Aesthetics*, vol. 45, no. 3: 248-257.
- Nauman, B. (2003) *Please Pay Attention Please: Bruce Nauman's Words*. Edited by Janet Kraynak (Cambridge, MA and London: MIT Press).
- Newman, M. and Bird, J. (eds.). (1999) *Rewriting Conceptual Art* (London: Reaktion).
- O'Hagan, S. (2008) The Interview: Richard Serra. *Observer*, Sunday 5 October 2008, Features: 6.
- Olin, M. (1992) *Forms of Representation in Alois Riegl's Theory of Art* (University Park, Pennsylvania: Pennsylvania State University Press).
- Osborne, P. (ed.). (2002) *Conceptual Art: Themes and Movements* (London and New York: Phaidon).
- Panofsky, E. (1935) The Friedsam Annunciation and the Problem of the Ghent Altarpiece. *The Art Bulletin*, vol. 17, no. 4: 433-473.
- _____. (1958) *Early Netherlandish Painting* (Cambridge Massachusetts).
- _____. (1969) *Renaissance and Renaissances in Western Art* (Stockholm: Almqvist and Wiksell).
- _____. (1991) *Perspective as Symbolic Form*. Translated by Christopher S. Wood (New York: Zone Books).
- Peacocke, C. (1987) Depiction. *Philosophical Review*, no. 96: 383-410.
- _____. (1992) *A Study of Concepts* (Cambridge, MA: The MIT Press).
- Penny, N. (1990) Architecture, Space, Figure and Narrative. *AA files* 20 (Autumn): 34-41.
- Pierce, C. S. (1985) Logic as Semiotic. In Innis, R. E. (ed.) *Semiotics: An Introductory Anthology*: 1-23 (Bloomington: Indiana University Press).
- Podro, M. (1998) *Depiction* (New Haven: Yale University Press).
- _____. (2001) The Artistry of Depiction. In van Gerwen, R. (ed.) *Richard Wollheim on the Art of Painting: Art as Representation and Expression*: 112-120 (Cambridge: Cambridge University Press).
- _____. (2004) On Richard Wollheim. *British Journal of Aesthetics*, vol. 44, no. 3: 213-225.
- Prendeville, B. (1999) Merleau-Ponty, Realism and Painting: Psychophysical Space and the Space of Exchange. *Art History* 22: 364-388.
- _____. (2005) Discernment. *Oxford Art Journal* 28.2: 213-226.
- Puttfarcken, T. (2000) *The Discovery of Pictorial Composition: Theories of Visual Order in Painting 1400-1800* (New Haven and London: Yale University Press).
- Raban, W. (2008) 2' 45" - Film Notes. Luxonline. Available from: http://www.luxonline.org.uk/artists/william_raban/2_45.html [Accessed 11 November 2008].
- Rauch, L. (1998) Sartre, Merleau-Ponty and the 'Hole in Being'. *Philosophical Studies* 18 (1969): 119-132. Reprinted in Stewart, J. (ed.) *The Aesthetic Dialogue of Sartre and Merleau-Ponty*: 1-15 (Evanston, Illinois: Northwestern University Press).
- Ravenal, J. (2002) *Outer and Inner Space* (Richmond, Virginia: Virginia Museum of Fine Arts).
- Rees, A. L. (2003) The Implied Viewer. In *Tony Sinden: Everything Must Go - Installation, Video and Film*: 8-27 (Sunderland: Reg Vardy Gallery, University of Sunderland).
- Reynolds, A. (2003) *Robert Smithson: Learning from New Jersey and Elsewhere* (Cambridge, MA and London: MIT Press).
- Riegl, A. (1999) *The Group Portraiture of Holland*. Introduction by Wolfgang Kemp, translated by Evelyn M. Kain (Los Angeles, California: Getty Research Center for the History of Art and the Humanities).
- Roberts, J. L. (2004) *Mirror-Travels: Robert Smithson and History* (New Haven and London: Yale University Press).
- Rotman, B. (1993) *Signifying Nothing: The Semiotics of Zero* (California: Stanford University Press).
- Rush, M. (1999) *New Media in Late 20th-Century Art* (London: Thames and Hudson).
- _____. (2003) *Video Art* (London: Tames and Hudson).
- Ryle, G. (2000) *The Concept of Mind* (London: Penguin Books).
- Sandström, S. (1963) *Levels of Unreality: Studies in Structure and Construction in Italian Mural Painting during the Renaissance* (Stockholm: Almqvist and Wiksell).
- Sartre, J. P. (1969) *Being and Nothingness*. Translated by Hazel E. Barnes, introduction by Mary

- Warnock. (London: University Paperback, Methuen & Co Ltd)
- _____. (1972) *The Psychology of Imagination* (London: Methuen).
- Savile, A. (1992) In Hopkins, J. and A. Savile (eds.) *Psychoanalysis, Mind and Art: Perspectives on Richard Wollheim*: 292-314 (Oxford: Blackwell).
- _____. (2007) Critical Notice: The Objective Eye. Review of *The Objective Eye: Color, Form, and Reality in the Theory of Art* by John Hyman. *British Journal of Aesthetics*, vol. 47, no. 4: 432-440.
- Schapiro, M. (1985) On Some Problems in the Semiotics of Visual Art: Field and Vehicle in Image-Signs. In *Semiotica* 1 (1969): 225-242. Reprinted in Innis, R. E. (ed.) *Semiotics: An Introductory Anthology*: 206-225 (Bloomington: Indiana University Press).
- Schier, F. (1986) *Deeper into Pictures* (Cambridge University Press).
- Schimmel (2003) Pay Attention. In *Bruce Nauman*. Exhibition organized by Kathy Halbreich and Neal Benezra: 69-82 (Minneapolis: Walker Art Center).
- Searle, J. R. (1980) *Las Meninas* and the Paradoxes of Pictorial Representation. *Critical Inquiry*, vol. 6, no. 3: 477-488.
- Segal, H. (1957) Notes on Symbol Formation. *International Journal of Psycho-Analysis*, no. 38.
- _____. (1991) *Dream, Phantasy, and Art* (London: Routledge).
- Sharp, W. (1970) Nauman Interview. *Arts Magazine*, vol. 44, no. 5 (March): 22-27.
- _____. (1971) Interview with Bruce Nauman. *Avalanche* 2 (Winter): 22-31.
- Shearman, J. (1992) *Only Connect...: Art and the Spectator in the Italian Renaissance* (New Jersey: Princeton University Press).
- Simon, J. (ed.). (1994) *Bruce Nauman*. Exhibition organized by Kathy Halbreich and Neal Benezra. (Minneapolis: Walker Art Center).
- Sinding-Larsen, S. (1962) Titian's *Madonna di Ca' Pesaro* and its Historical Significance. *Acta ad archaeologiam et artium historiam pertinentia*, 1: 139-169.
- Smith, M. B. (1993) Merleau-Ponty's Aesthetics. In *Les Etudes Philosophiques* 1 (1988), 73-98. Reprinted in Johnson, G. A. (ed.) *The Merleau-Ponty Aesthetics Reader: Philosophy and Painting*. Michael B. Smith, Translation Editor: 192-211 (Evanston, Illinois: Northwestern University Press).
- Smithson, R. (1996) *Robert Smithson: The Collected Writings*. Edited by Jack Flam (Berkeley, Los Angeles and London: University of California Press).
- Snow, E. (1994) *A Study of Vermeer* (Berkeley and Los Angeles, California: University of California Press).
- Snyder, J. (1985) *Las Meninas* and the Mirror of the Prince. *Critical Inquiry*, vol. 11, no. 4: 539-572.
- Snyder, J. and Cohen, T. (1980) Reflexions on *Las Meninas*: Paradox Lost. *Critical Inquiry*, vol. 7, no. 2: 429-447.
- Spencer, J. R. (1955) Spatial Imagery of the Annunciation in Fifteenth Century Florence. *The Art Bulletin*, vol. 37, no. 4: 273-280.
- Spike, J. T. (1996) *Masaccio* (London and New York: Abbeville).
- Spinicci, P. (2008) Unpublished Manuscript. E-mailed to Author November 2008.
- Steadman, P. (2002) *Vermeer's Camera: Uncovering the Truth Behind the Masterpieces* (Oxford and New York: Oxford University Press).
- Steinberg, L. (1981) Velázquez' *Las Meninas*. *October*, vol. 19, Winter: pp. 45-54.
- Stewart, J. (ed.). (1998) *The Debate between Sartre and Merleau-Ponty* (Evanston, Illinois: Northwestern University Press).
- Stokes, A. (1955) *Form in Art*. In Klein, M., P. Heimann, and R. E. Money-Kyrle (eds.) *New Directions in Psychoanalysis*: 406-420 (New York: Basic Books).
- _____. (1978) *The Critical Writings of Adrian Stokes*. Edited by Lawrence Gowing, vol.1: 1930-1937, vol. 2: 1937-58, vol. 3: 1955-1967 (London: Thames and Hudson).
- Summers, D. (2003) *Real Spaces: World Art History and the Rise of Western Modernism* (London and New York: Phaidon).
- Sutton, P. C. (org.). (1984) *Masters of Seventeenth-Century Dutch Genre Painting* (Philadelphia: Philadelphia Museum of Art).
- Sutton, P. C. (1998) *Pieter de Hooch 1629-1684* (New Haven and London: Yale University Press in association with Dulwich Picture Gallery and Wadsworth Atheneum).
- Taylor, C. (2005) Merleau-Ponty and the Epistemological Picture. In Carman, T. and M. B. N. Hansen (eds.) *The Cambridge Companion to Merleau-Ponty*: 26-73 (Cambridge: Cambridge University Press).
- Turrell, J. (2002) Work Series 1966-98. In *James Turrell: The Other Horizon*: 57-186. Edited by Peter Noever (Vienna and Ostfildern-Ruit, Germany: MAK und Hatje Cantz Verlag).
- van de Vall, R. (2001) The Staging of Spectatorship. In van Gerwen, R. (ed.) *Richard Wollheim on the Art of Painting: Art as Representation and Expression*: 177-188 (Cambridge: Cambridge University Press).
- van Eck, C. (2001) The Case for the Internal Spectator: Aesthetics or Art History. In van Gerwen, R. (ed.) *Richard Wollheim on the Art of Painting: Art as Representation and Expression*: 200-214

- (Cambridge: Cambridge University Press).
- van Gerwen, R. (ed.). (2001) *Richard Wollheim on the Art of Painting: Art as Representation and Expression* (Cambridge: Cambridge University Press).
- Walton, K. (1990) *Mimesis as Make-Believe: On the Foundations of the Representational Arts* (Cambridge, MA and London: Harvard University Press).
- _____. (1992) Seeing-In and Seeing Fictionally. In Hopkins, J. and A. Savile (eds.) *Psychoanalysis, Mind and Art: Perspectives on Richard Wollheim*: 281-291 (Oxford: Blackwell).
- _____. (2002) Depiction, Perception, and Imagination: Responses to Richard Wollheim. *The Journal of Aesthetics and Art Criticism*, no. 60.1: 27-35.
- _____. (2004) Are Representations symbols? *The Monist*, no. 58:2 (1974): 236-254. (Illinois: International Quarterly Journal of General Philosophical Inquiry). Reprinted in Lamarque, P. and Olsen, S. H. (eds.) *Aesthetics and the Philosophy of Art: The Analytic Tradition*: 349-358 (Malden, Oxford and Carlton, Australia: Blackwell Publishing).
- Wheelock, A. K. (1988) *Vermeer* (London: Thames and Hudson).
- _____. (ed.). (1995) *Johannes Vermeer* (New Haven and London: Yale University Press, with the National Gallery of Art, Washington, and the Royal Cabinet of Paintings Mauritshuis, The Hague).
- White, J. (1972) *The Birth and Rebirth of Pictorial Space* (London: Faber and Faber).
- Wilde, C. (2001) Style and Value in the Art of Painting. In van Gerwen, R. (ed.) *Richard Wollheim on the Art of Painting: Art as Representation and Expression*: 121-134 (Cambridge: Cambridge University Press).
- Wilder, K. (2007) Negotiating Painting's Two Perspectives: A Role for the Imagination. *Image [&] Narrative* [e-journal], no. 18. Available from: http://www.imageandnarrative.be/thinking_pictures/wilder.htm
- _____. (2008) The Case for an External Spectator. *British Journal of Aesthetics*, vol. 48, no. 3: 261-277.
- Williams, B. (1973) *Problems of the Self: Philosophical Papers 1956-1972* (Cambridge: Cambridge University Press).
- Wimsatt, K. (1967) *The Verbal Icon: Studies in the Meaning of Poetry* (Lexington: University Press of Kentucky).
- Winnicott, D. W. (1958) Transitional Objects and Transitional Phenomena. In Winnicott, D. W. *Collected Papers: Through Paediatrics to Psycho-Analysis* (London: Tavistock Publications).
- _____. (1991) *Playing and Reality* (London and New York: Tavistock/Routledge).
- Wittgenstein, L. (2001) *Philosophical Investigations*. Translated by G. E. M. Anscombe (Oxford: Blackwell).
- Wittkower, R. (1978) *Idea and Image: Studies in the Italian Renaissance* (London: Thames and Hudson).
- Wölfflin, H. (1950) *Principles of Art History: The Problem of the Development of Style in Later Art*. Translated by M. D. Hottinger (New York: Dover Publications).
- Wollheim, R. (1973) *On Art and the Mind* (London: Allen Lane).
- _____. (1980a) *Art and its Objects*, 2nd ed. (Cambridge: Cambridge University Press).
- _____. (1980b) Seeing-as, Seeing-in, and Pictorial Representation. In *Art and its Objects*, 2nd ed.: 205-226 (Cambridge: Cambridge University Press).
- _____. (1980c) Criticism as Retrieval. In *Art and its Objects*, 2nd ed.: 185-204 (Cambridge: Cambridge University Press).
- _____. (1984) *The Thread of Life* (New Haven and London: Yale University Press).
- _____. (1986) Imagination and Pictorial Understanding. *Proceedings of the Aristotelian Society, Supplement* 60: 45-60.
- _____. (1987) *Painting as an Art* (London: Thames and Hudson).
- _____. (1991) Correspondence, Projective Properties, and Expression in the Arts. In Kernal, S. and I. Gaskell (eds.) *The Language of Art History*: 51-66 (New York: Cambridge University Press).
- _____. (1993) *The Mind and its Depths* (Cambridge, Massachusetts: Harvard University Press).
- _____. (1999) *On the Emotions* (New Haven and London: Yale University Press).
- _____. (2001a) On Pictorial Representation. In van Gerwen, R. (ed.) *Richard Wollheim on the Art of Painting: Art as Representation and Expression*: 13-27 (Cambridge: Cambridge University Press).
- _____. (2001b) A Reply to the Contributors. In van Gerwen, R. (ed.) *Richard Wollheim on the Art of Painting: Art as Representation and Expression*: 241-261 (Cambridge: Cambridge University Press).

List of Illustrations

- Fig. 1 Nicolaes Maes: *The Eavesdropper* (1655), Collection of Harold Samuel, London. 19
- Fig. 2 Masaccio: *Trinity* (c. 1425-27), Santa Maria Novella, Florence. 23
- Fig. 3 Johannes Vermeer: *The Music Lesson* (c. 1662-65), Her Majesty Queen Elizabeth II, London. 39
- Fig. 4 Johannes Vermeer: *The Music Lesson* (detail). 40
- Fig. 5 Rembrandt: *Jan Six* (1654), Foundation Six, Amsterdam. 43
- Fig. 6 Johannes Vermeer: *Artist in His Studio* (c. 1666-67), Kunsthistorisches Museum, Vienna. 45
- Fig. 7 Johannes Vermeer: *Artist in His Studio* (detail). 45
- Fig. 8 Mantegna: *Camera degli Sposi* (frescoed vault; c. 1465), Castello di San Giorgio, Mantua. 54
- Fig. 9 Masaccio: *Trinity* (detail; c. 1425-27), Santa Maria Novella, Florence. 55
- Fig. 10 Johannes Vermeer: *A Lady Writing a Letter* (c. 1665-66), National Gallery of Art, Washington. 57
- Fig. 11 Antonello da Messina: *St Jerome* (c. 1450-55), National Gallery, London. 71
- Fig. 12 Giovanni Bellini: *Virgin and Child Enthroned with Saints (San Zaccaria Altarpiece)* (1505), San Zaccaria, Venice. 81
- Fig. 13 Giovanni Bellini: *Madonna Enthroned and Saints (San Giobbe Altarpiece)* (c. 1480), Galleria dell' Accademia, Venice. 87
- Fig. 14 Photomontage reconstruction of Giovanni Bellini's *San Giobbe Altarpiece*, in its stone frame within San Giobbe (reproduced from Shearman 1992, p. 96). 88
- Fig. 15 Titian: *Pesaro Altarpiece* (1519-26), S. Maria Gloriosa dei Frari, Venice. 91
- Fig. 16 Giovanni Bellini: *St Jerome with SS Christopher and Louis of Toulouse* (1513), San Giovanni Crisostomo, Venice. 95
- Fig. 17 Rembrandt: *The Syndics* (1662), Rijksmuseum, Amsterdam. 97
- Fig. 18 Rembrandt: *The Anatomy Lesson of Dr Tulp* (1632), Mauritshuis, The Hague. 98
- Fig. 19 Frans Hals: *The Regents of Saint Elizaboeth's Hospital* (1641), City Museum, Haarlem. 99
- Fig. 20 Gerard Dou: *Self-Portrait with Book and Pipe* (c. 1650), Rijksmuseum, Amsterdam. 100
- Fig. 21 Jean-Baptiste Siméon Chardin: *The House of Cards* (c. 1737), National Gallery of Art, Washington. 101
- Fig. 22 Gerard ter Borch: *Curiosity*, The Metropolitan Museum of Art, New York. 102
- Fig. 23 Johannes Vermeer: *A Girl Interrupted at her Music* (c.1660-61), The Frick Collection, New York. 104
- Fig. 24 Johannes Vermeer: *The Love Letter* (c. 1669-70), Rijksmuseum, Amsterdam. 104

- Fig. 25 Johannes Vermeer: *Soldier and Laughing Girl* (c. 1658), The Frick Collection, New York. 106
- Fig. 26 Johannes Vermeer: *Guitar Player* (c. 1672), Kenwood House, Lord Iveagh Bequest, London. 106
- Fig. 27 Johannes Vermeer: *A Woman in Blue Reading a Letter* (c. 1662-64), Rijksmuseum, Amsterdam. 107
- Fig. 28 Johannes Vermeer: *A Woman Holding a Balance* (c. 1662-64), National Gallery of Art, Washington. 107
- Fig. 29 Velázquez: *Las Meninas* (1656), Museo del Prado, Madrid. 112
- Fig. 30 Velázquez: *Las Meninas* (detail). 115
- Fig. 31 Velázquez: *Las Meninas*, diagram of perspective construction, according to Snyder (1983). 117
- Fig. 32 Reconstruction of the ground plan in the Alcázar Palace, according to John Moffitt (1983). 118
- Fig. 33 Velázquez: *Las Meninas*, reconstruction of painting by John Moffitt (1983). 118
- Fig. 34 *Ecstasy of St Francis* (c. 1274-84), Upper Church, Basilica of San Francesco, Assisi. 126
- Fig. 35 Giotto: *Ascension* (c. 1305-10), Arena Chapel, Padua. 126
- Fig. 36 Masolino: *Foundation of Santa Maria Maggiore* (c. 1428-32), Museo Nazionale di Capodimonte, Naples. 127
- Fig. 37 Mantegna: *Resurrection* (c. 1462-64), Galleria degli Uffizi, Florence. 128
- Fig. 38 Giovanni Bellini: *Resurrection* (c. 1479), Gemäldegalerie, Berlin. 129
- Fig. 39 Titian: *Polyptych of the Resurrection* (1520-22), Santi Nazaro e Celso, Brescia. 130
- Fig. 40 Correggio: *Assumption of the Virgin* (1526-30), Parma Cathedral. 131
- Fig. 41 Correggio: *Vision of St John* (1520-24), San Giovanni Evangelista, Parma. 131
- Fig. 42 Correggio: *Vision of St John* (detail). 132
- Fig. 43 Pintoricchio: *San Bernardino in Glory* (1482-85), Bufalini Chapel, Santa Maria in Aracoeli, Rome. 134
- Fig. 44 Pintoricchio: West Wall (1482-85), Bufalini Chapel, Santa Maria in Aracoeli, Rome. 134
- Fig. 45 Masaccio: *Trinity* (detail), Santa Maria Novella, Florence. 137
- Fig. 46 Andrea del Castagno: *The Trinity Appearing to St Jerome* (c. 1455), Corboli Chapel, SS Annunciata, Florence. 139
- Fig. 47 Mantegna: *Assumption* (1449-55), Overtari Chapel, Chiesa degli Eremitani, Padua. 139
- Fig. 48 Piero della Francesca: *Resurrection* (c. 1460), Museo Civico, Sansepolcro. 140
- Fig. 49 Hans Holbein: *The Dead Christ in the Tomb* (1521-22), Öffentliche Kunstsammlung, Basel. 141
- Fig. 50 Mantegna: *Dead Christ* (c. 1480-1500), Pinacoteca di Brera, Milan. 142
- Fig. 51 Piero della Francesca: *The Dream of Constantine, The Story of the True Cross* (1452-66), San Francesco, Arezzo. 144
- Fig. 52 Giovanni Bellini: *Madonna of the Meadow* (c. 1500-05), National Gallery, London. 145
- Fig. 53 Piero della Francesca: *Madonna di Senigallia* (c. 1478-80), Galleria Nazionale delle Marche, Urbino. 146
- Fig. 54 Fra Angelico: *Annunciation* (c. 1430-31), Museo Diocesano, Cortona. 147
- Fig. 55 Johannes Vermeer: *Girl Asleep* (c. 1657), The Metropolitan Museum of Art, New York. 148

- Fig. 56 Nicolaes Maes: *The Idle Servant* (c. 1657), National Gallery, London. 149
- Fig. 57 Johannes Vermeer: *Girl Asleep* (X-ray detail), The Metropolitan Museum of Art, New York (Snow 1994, p. 187). 149
- Fig. 58 Pieter de Hooch: *Woman Lacing her Bodice beside a Cradle* (1661-63), Gemäldegalerie, Berlin. 150
- Fig. 59 Rembrandt: *Self-Portrait* (1661), Kenwood House, Lord Iveagh Bequest, London. 159
- Fig. 60 Caravaggio: *The Entombment* (c. 1602-04), Pinacoteca Vaticana, Rome. 165
- Fig. 61 Shirin Neshat: *Rapture* (1999). 173
- Fig. 62 Michael Asher: *Installation* (1970), Pomona College Art Gallery, California. 175
- Fig. 63 James Turrell: *Skyspace* (2006), Deer Shelter, Yorkshire Sculpture Park, Yorkshire. 175
- Fig. 64 James Turrell: *Danae* (1983), Mattress Factory, Pittsburgh, Pennsylvania. 176
- Fig. 65 Dan Flavin: *Untitled (to Jan and Ron Greenberg)* (1972-3), Dia Art Foundation, New York. 177
- Fig. 66 Bruce Nauman: *Green Light Corridor* (1970-71), The Solomon R. Guggenheim Foundation (Panza Gift), New York. 178
- Fig. 67 Bruce Nauman: *Double Wedge Corridor (With Mirror)* (1970-74), The Solomon R. Guggenheim Foundation (Panza Gift), New York. 179
- Fig. 68 Bruce Nauman: *Live/Taped Video Corridor* (1969-70), The Solomon R. Guggenheim Foundation (Panza Gift), New York. 179
- Fig. 69 Dan Graham: *Present Continuous Past(s)* (1974), Centre Georges Pompidou, Paris. 180
- Fig. 70 Anthony McCall: *Line Describing a Cone* (1973). 181
- Fig. 71 William Raban: *2'45"* (1973). 181
- Fig. 72 Tony Sinden: *Cool Room* (2002); Ken Wilder: *Intersection* (2006). 182
- Fig. 73 Jan van Eyck: *Arnolfini Wedding* (detail; 1434), National Gallery, London. 187
- Fig. 74 Albrecht Dürer: woodcut from *The Painter's Manual* (1525), National Gallery of Victoria, Melbourne. 188
- Fig. 75 Titian: *Pesaro Altarpiece*, earlier stage according to Sinding-Larsen (drawn by Puttfarken). 195
- Fig. 76 Jan van Eyck: *Arnolfini Wedding* (1434), National Gallery, London. 196
- Fig. 77 Pieter de Hooch: *The Interior of the Burgomasters' Council Chamber in the Amsterdam Town Hall with Visitors* (c. 1663-65), Museo Thyssen-Bornemisza, Madrid. 197
- Fig. 78 Johannes Vermeer: *A Woman Reading at the Window* (c. 1657), Rijksmuseum, Amsterdam. 197
- Fig. 79 Rembrandt: *Woman in Bed (Sarah, Wife of Tobias)* (c. 1645), National Gallery of Scotland, Edinburgh. 199
- Fig. 80 Giotto: *St Francis Appearing to the Brethren at Arles* (1315-20), Bardi Chapel, S. Croce, Florence. 201
- Fig. 81 Giotto: *Annunciation (Gabriel)* (c. 1305-10), Arena Chapel, Padua. 201
- Fig. 82 Giotto: *Annunciation (The Virgin)* (c. 1305-10), Arena Chapel, Padua. 201
- Fig. 83 Andrea Pozzo: *Transmission of the Divine Spirit* (1691-94), S. Ignazio, Rome. 202
- Fig. 84 Piero della Francesca: *The Flagellation of Christ* (c. 1460), Galleria Nazionale delle Marche, Urbino. 203
- Fig. 85 Lorenzo Monaco: *Annunciation* (c. 1420-24), Santa Trinita Church, Florence. 204

- Fig. 86 Petrus Christus: *Annunciation* (c. 1450), The Metropolitan Museum of Art, New York. 204
- Fig. 87 Domenico Veneziano: *Annunciation* (c. 1445-47), Fitzwilliam Museum, Cambridge. 204
- Fig. 88 Pieter de Hooch: *A Woman Delousing a Child's Hair* (c. 1658-60), Rijksmuseum, Amsterdam. 205
- Fig. 89 Pieter de Hooch: *Woman Drinking with Soldiers* (1658), Musée du Louvre, Paris. 207
- Fig. 90 Edward Hopper: *Hotel Room* (1931), Museo Thyssen-Bornemisza, Madrid. 207
- Fig. 91 Vilhelm Hammershøi: *Strandgade 30* (1901), Private Collection. 207

List of Published and Exhibited Works

Journal articles arising from research

- Wilder, K. (2006) A Spatiality of Situation. *Art In-Sight/Filmwaves*, no. 31: pp. 16-18.
- _____. (2007) Negotiating Painting's Two Perspectives: A Role for the Imagination. *Image [&] Narrative* [e-journal], no. 18. Available from: http://www.imageandnarrative.be/thinking_pictures/wilder.htm
- _____. (2008) The Case for an External Spectator. *British Journal of Aesthetics*, vol. 48, no. 3: 261-277.

Exhibitions of works included in submission

- 2000 Performance Architecture: Group Exhibition, Exhibited #226, 291 Gallery, Hackney, London.
- 2002 Reflections: Group Exhibition, Exhibited *Suspended*, gf2 Gallery, Soho, London.
- 2002 *I was once as you are...* : Solo Exhibition (Installation), Kingsgate Gallery, West Hampstead, London.
- 2003 *Plenum #1*: Solo Exhibition (Installation), 97-99 Gallery, Spitalfields, London.
- 2003 *Conduit*: Solo Exhibition (Installation), M² Gallery, Peckham, London.
- 2004 Projective Space: Solo Exhibition, Exhibited *Plenum #2, Milky Voids, San Lorenzo #1*, Galerie Sebastianskapelle, Ulm, Germany.
- 2005 Performance Furniture: Group Exhibition, Exhibited *Chamber, Plenum #2*, Triangle Space, Chelsea College of Art and Design, London.
- 2006 *Passage*: Solo Exhibition (Installation), M² Gallery, Peckham, London.
- 2006 Angles of Projection: Group Exhibition, Exhibited *Intersection*, Triangle Space, Chelsea College of Art and Design, London.
- 2007 Black and White: Group Exhibition, Exhibited *Milky Voids*, Gallery 12, Hampstead, London.
- 2009 Limbo: Group Exhibition, Exhibited *Suspended*, Crypt Gallery, Euston, London.

Publications of works included in submission

- Littlefield, D. (2007) Milky Voids: The Reinterpretation of a Mining Building. In Littlefield, D. and S. Lewis, *Architectural Voices: Listening to Old Buildings*: 136-141 (West Sussex: Wiley).

Part Two



p. 226

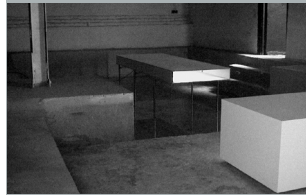

p. 229



p. 232



p. 238



p. 244



p. 250



p. 224



p. 228



p. 230

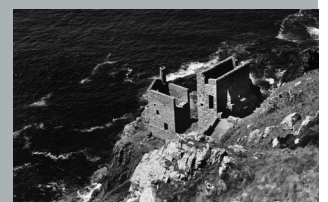

p. 234



p. 242



p. 246

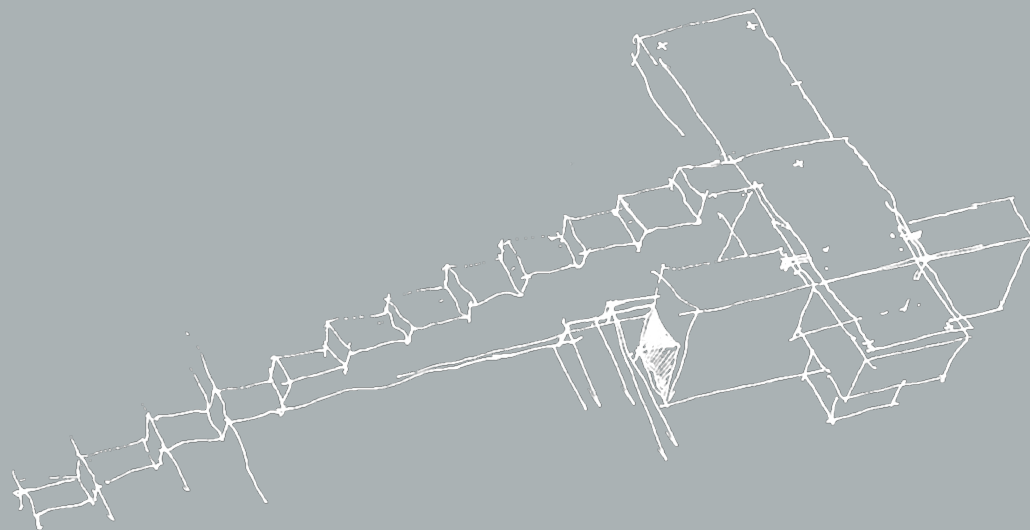

2000

Materials: Acrylic, steel, mdf, fluorescent lights, 3 x video projections (looped)

Installation: 291 Gallery, Hackney, London

Performer: Chris Swain

Metalwork: Michael Sanders

Fabrication: Dieter Pietsch, Mick Stickland and Stef Willis (in collaboration with artist)

Photography: Alex Madjitey

226

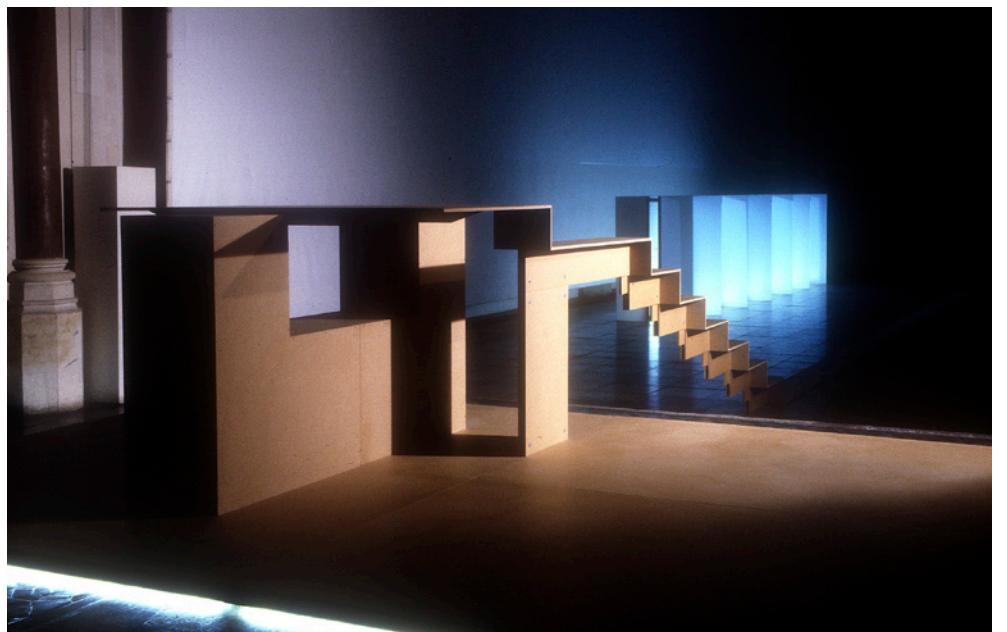
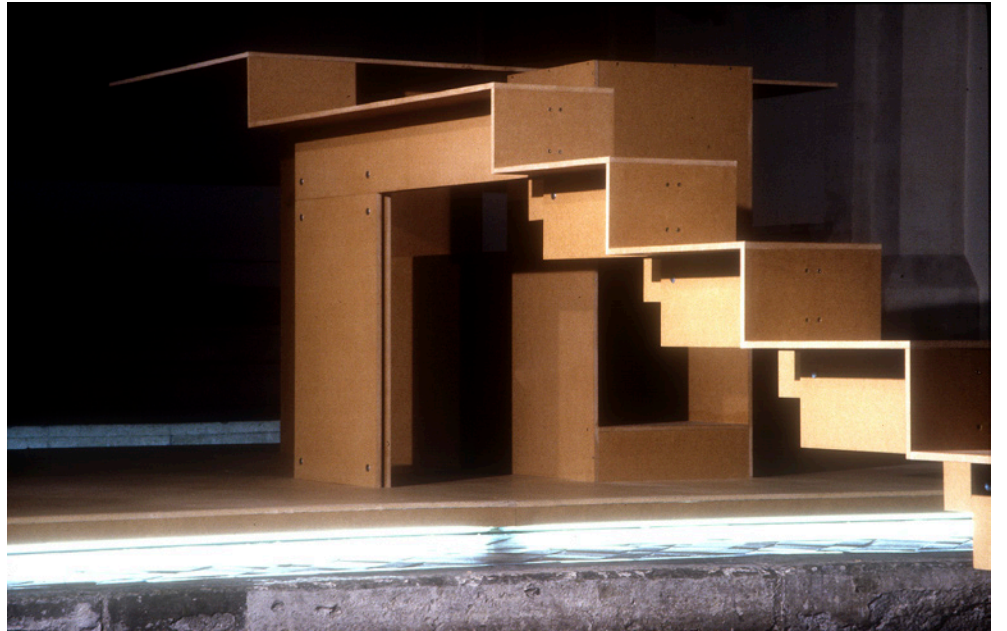
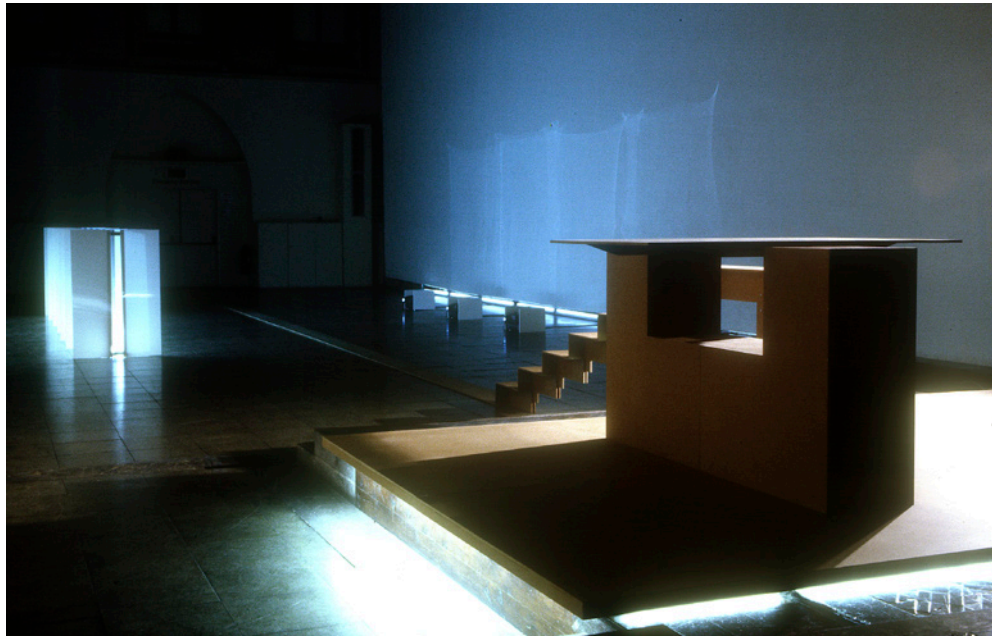

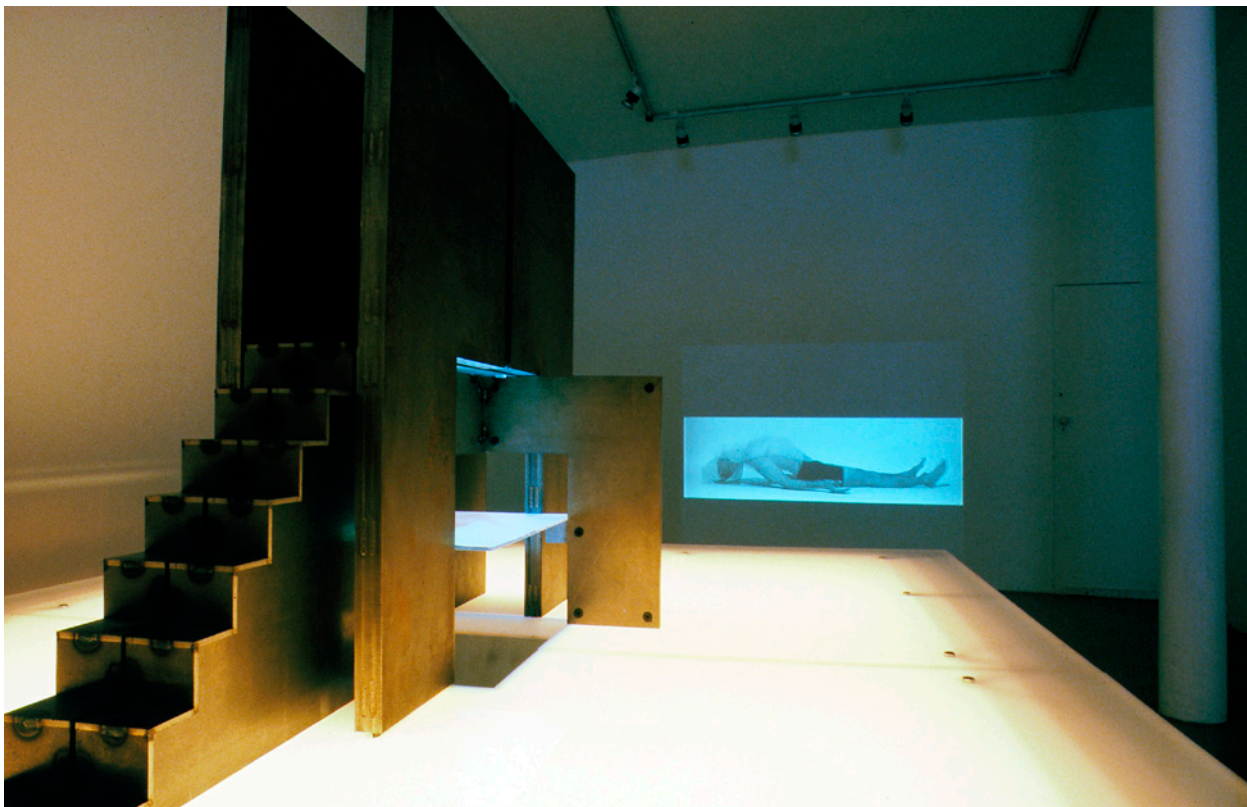

I WAS ONCE AS YOU ARE...

2002

Materials: Acrylic, steel, plywood, fluorescent lights, 2 x dvd projections (looped)
Installation: Kingsgate Gallery, West Hampstead, London
Performer: Chris Swain
Metalwork: Michael Sanders
Fabrication: Mick Stickland and Stef Willis (in collaboration with artist)
Photography: Artist
CAD: Artist

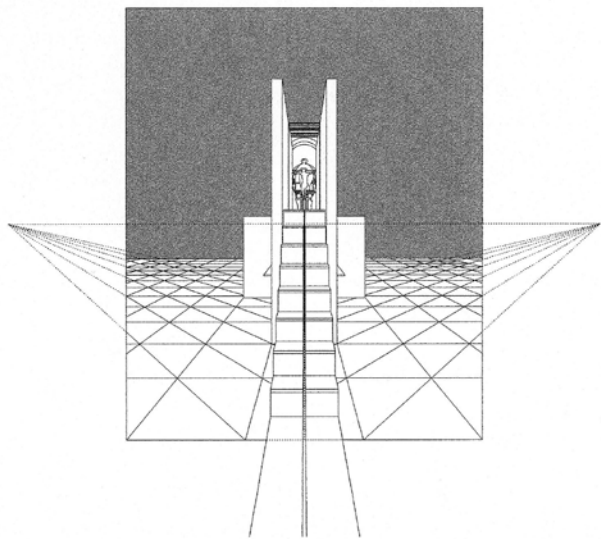
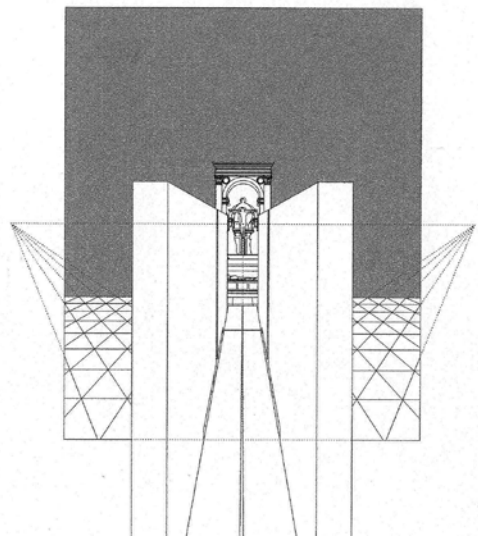
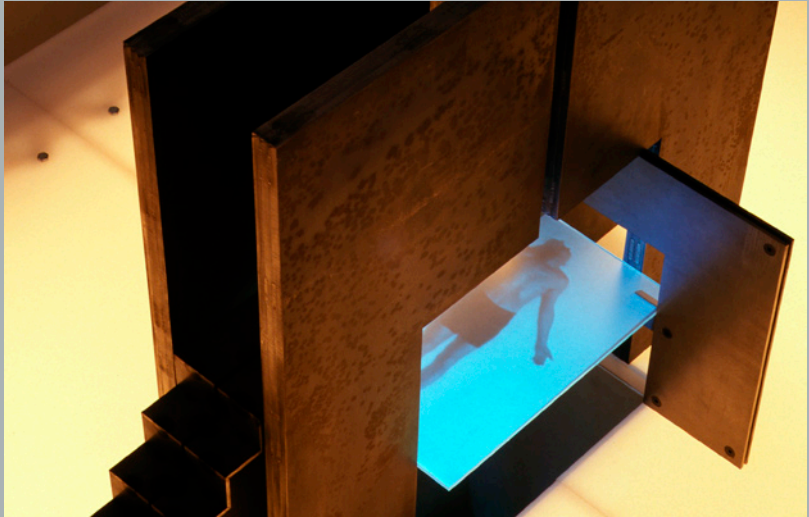

SUSPENDED

2002

Materials: Steel, acrylic, water, dvd projection (looped)
Installation: gf2 Gallery, Soho, London
Performer: Chris Swain
Metalwork: Michael Sanders
Photography: Alex Madjitey

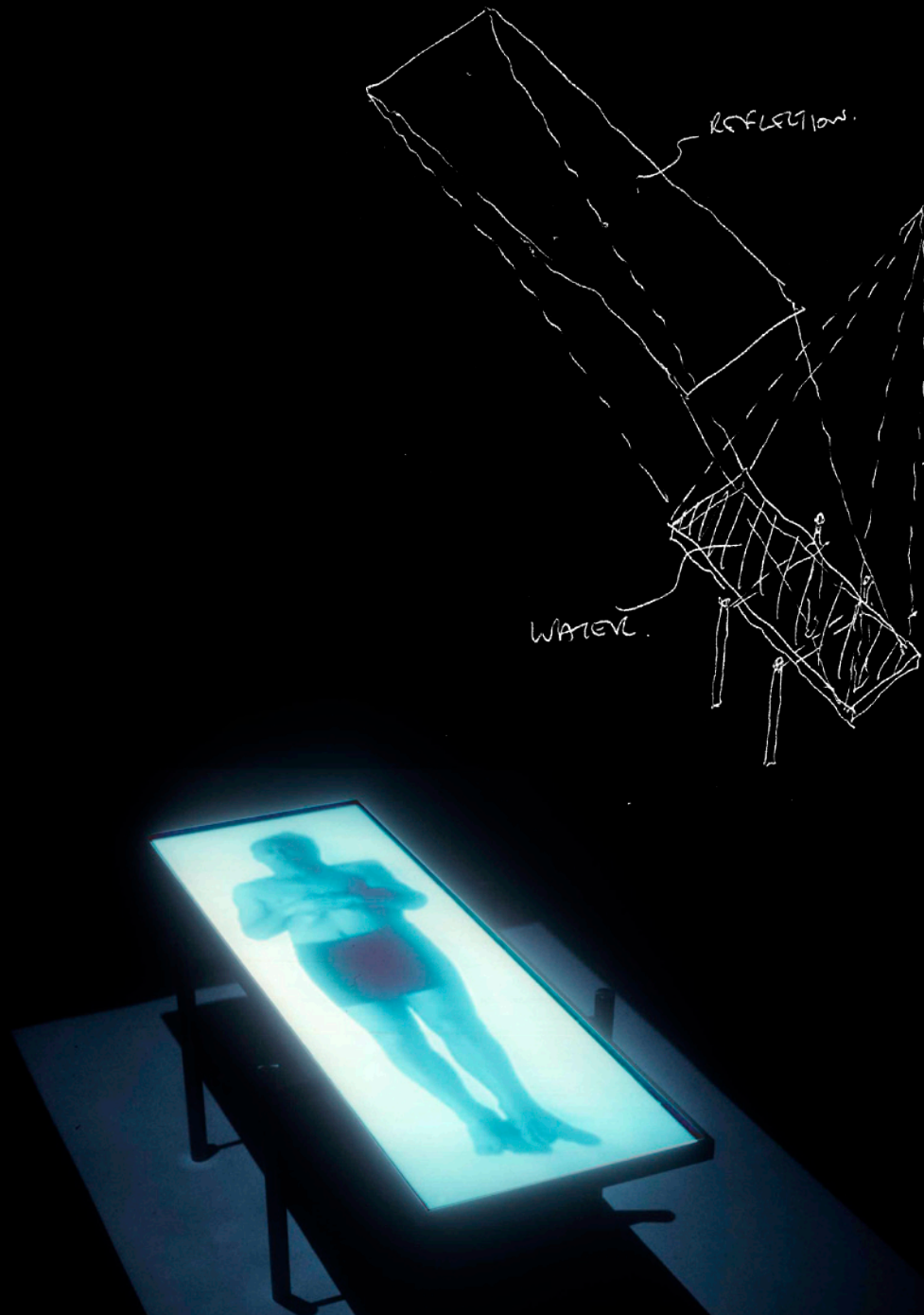

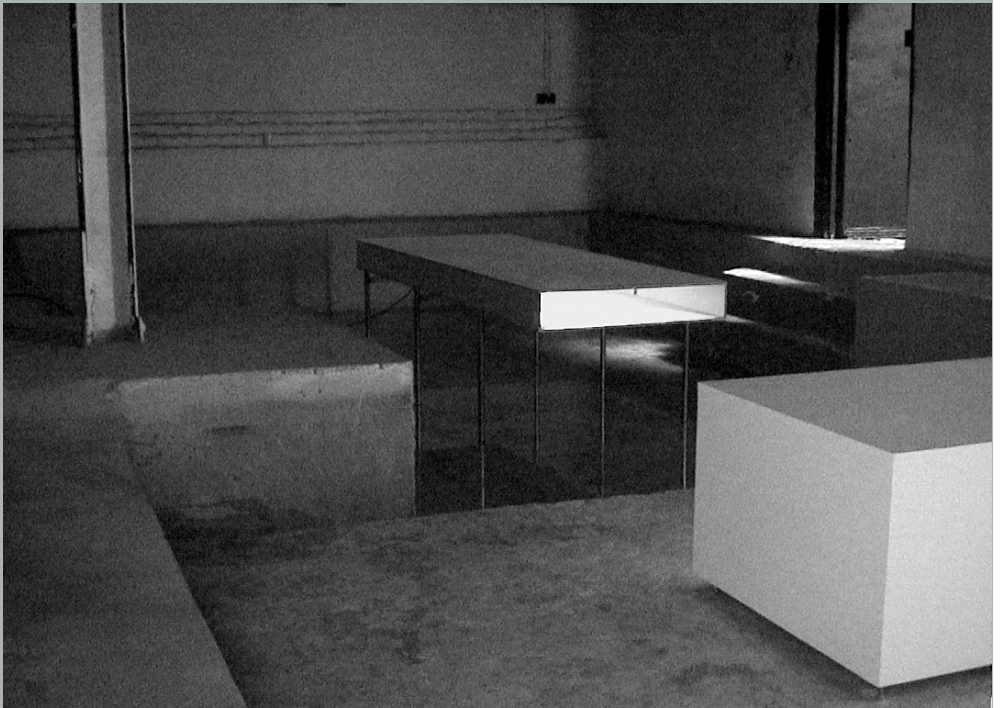
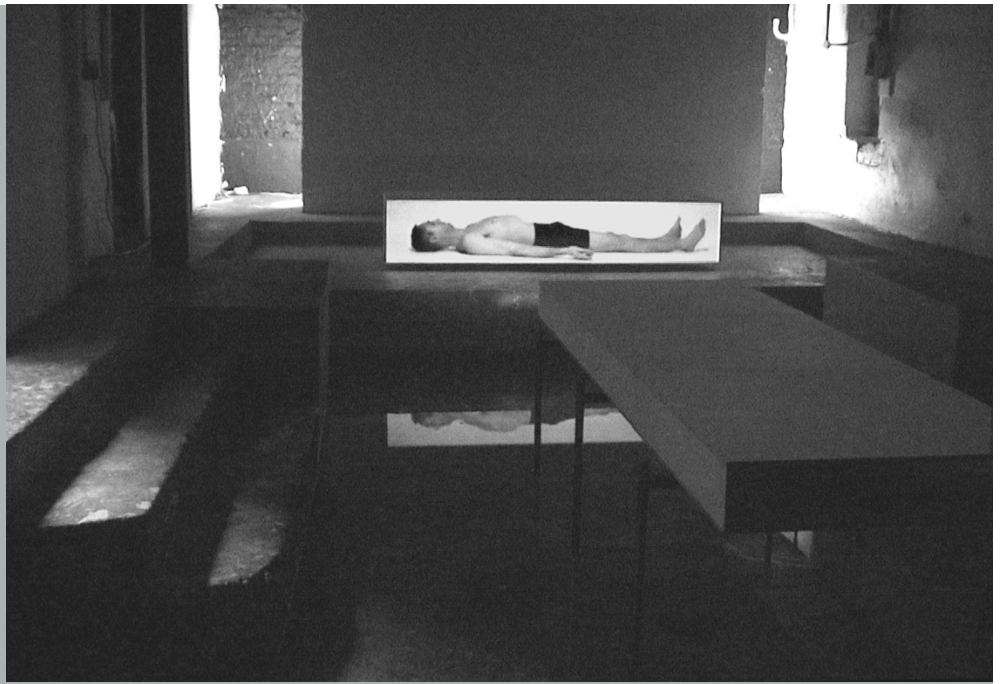

PLENUM #1

2003

Materials: Steel, plywood, water, dvd projection (looped)
Installation: 97-99 Gallery, Spitalfields, London
Performer: Chris Swain
Metalwork: Michael Sanders
Fabrication: Mick Stickland and Stef Willis (in collaboration with artist)
Photography: Artist



CONDUIT

2003

Materials: Steel, dvd on monitor (looped)
Installation: M² Gallery, Peckham, London
Performer: Chris Swain
Metalwork: Michael Sanders
Photography: Artist
CAD: Ge Fei Dong

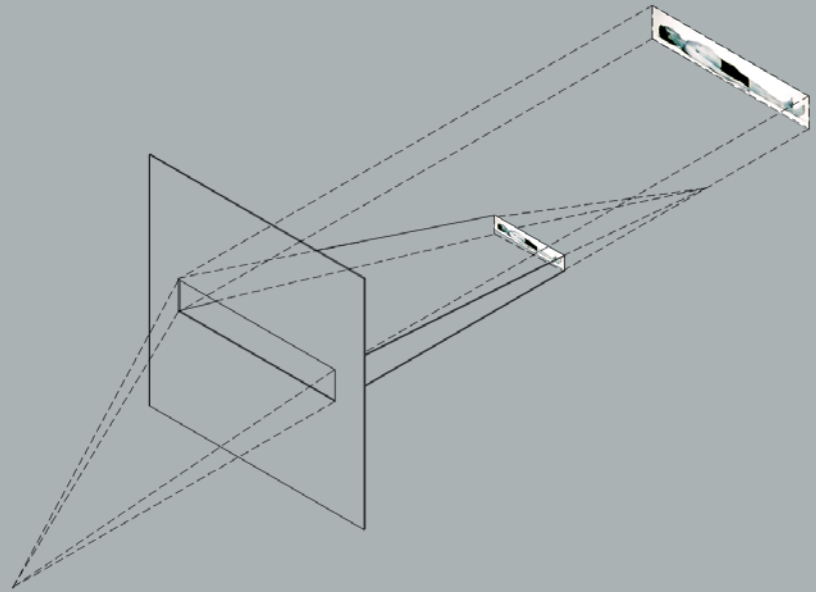
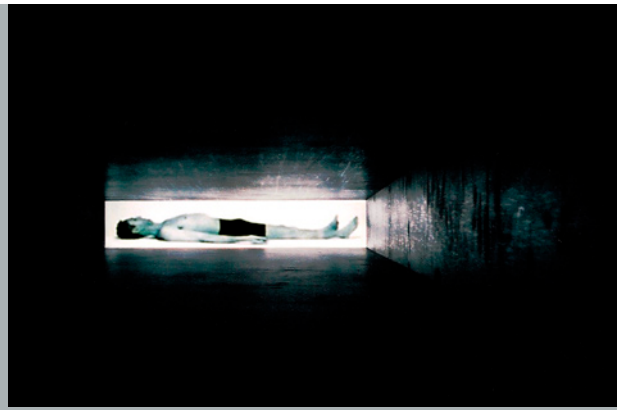

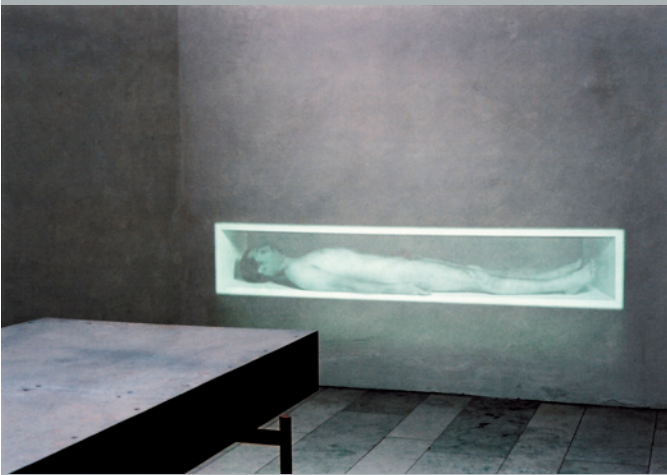
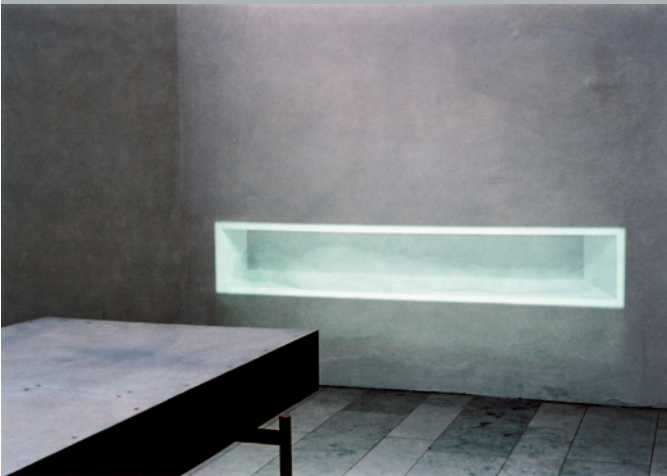
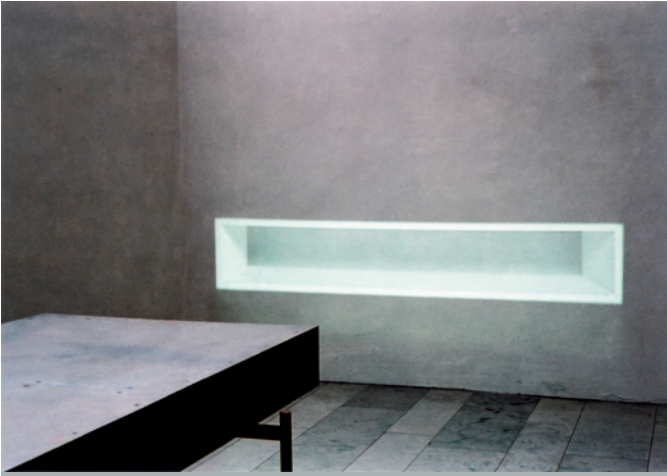

PLENUM #2

2004

Materials: Steel, dvd projection (looped)
Installation: Galerie Sebastianskapelle, Ulm, Germany;
Triangle Space, Chelsea College of Art and Design, London
Performer: Artist
Metalwork: Michael Sanders
Photography: Artist
CAD: Ge Fei Dong

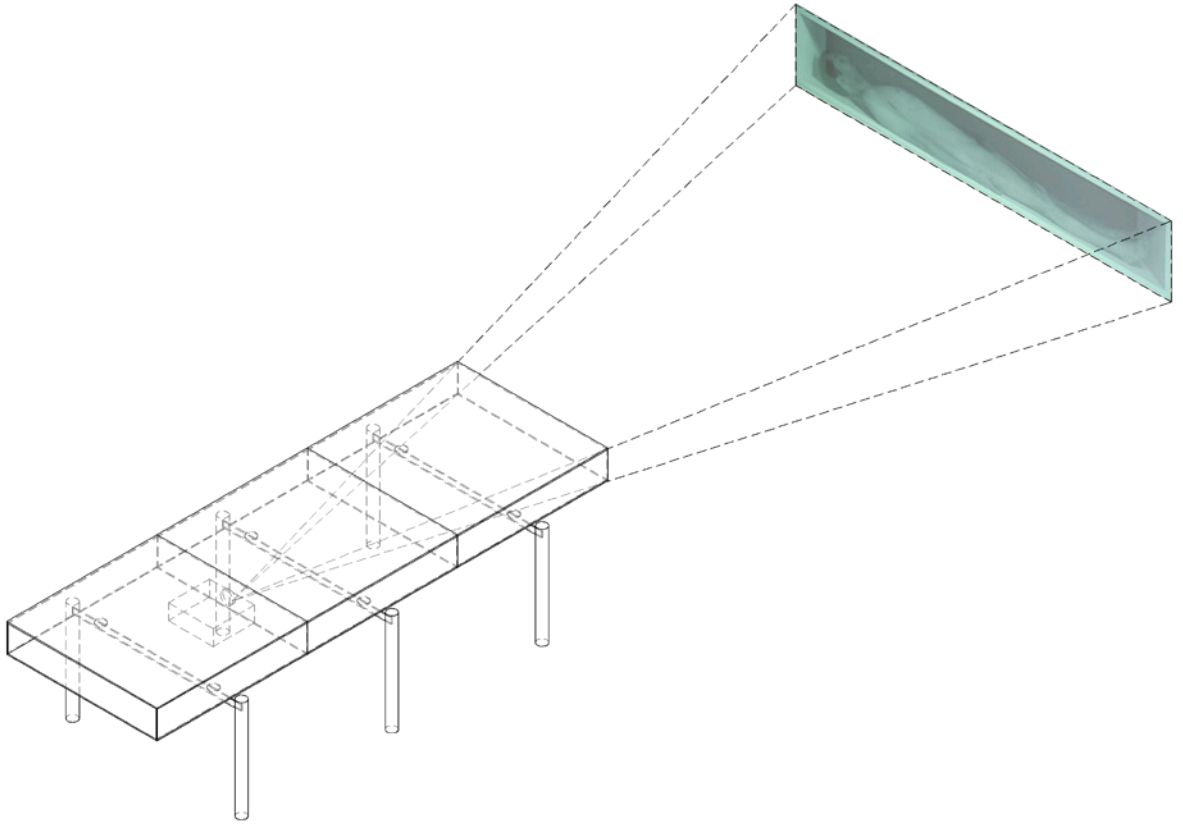



MILKY VOIDS

2004

- Materials:** Milk, mdf trays, timber supports; dvd (looped) + photographic series
- Installation:** Botallack tin and copper mine, Cornwall
- Exhibited:** Galerie Sebastianskapelle, Ulm, Germany
G12 Gallery, Hampstead, London
- Fabrication:** Mick Stickland and Stef Willis (in collaboration with artist)
- Construction:** Artist, Philip Harrison
- Photography:** Philip Harrison (in collaboration with artist)
- Filming:** Artist

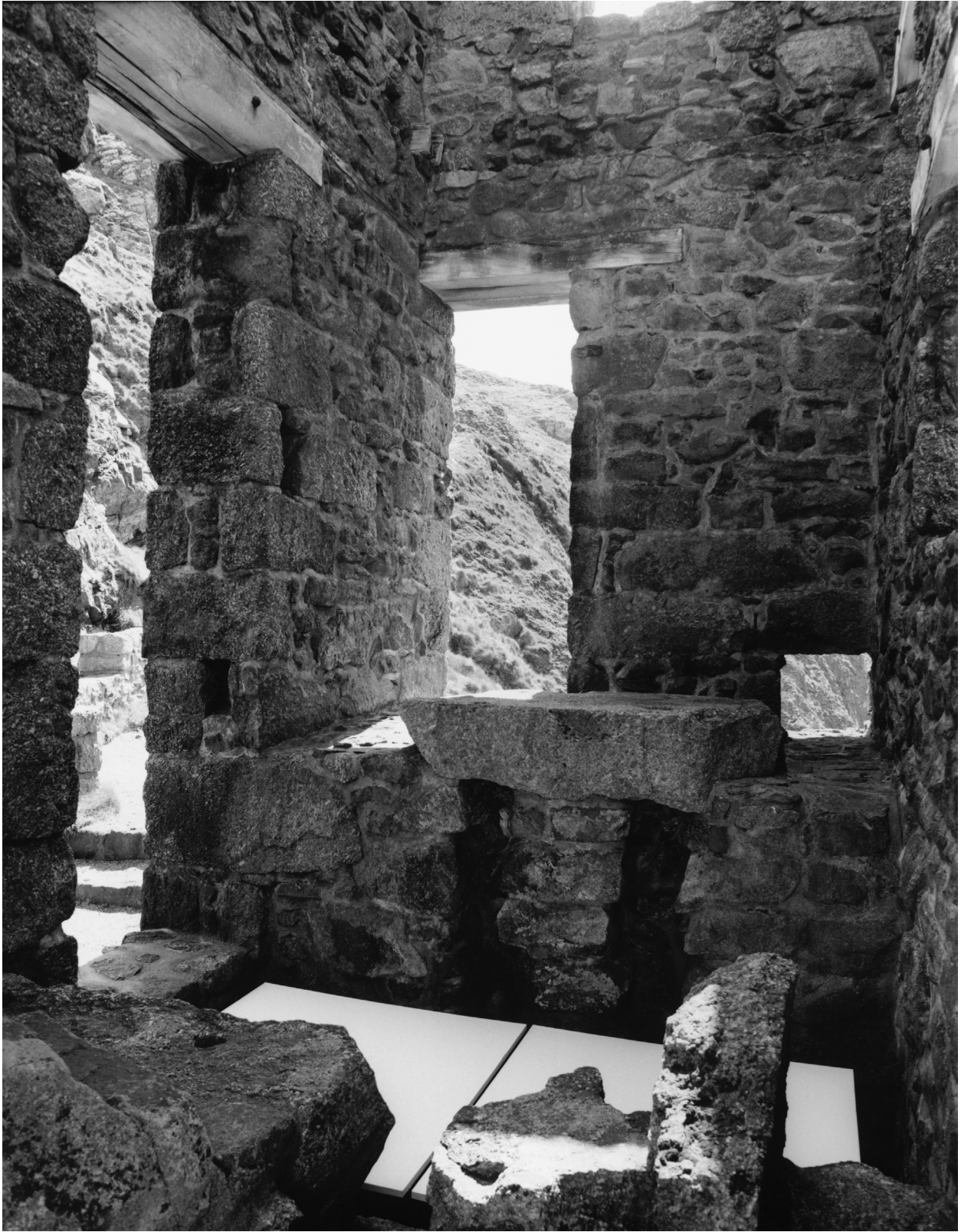





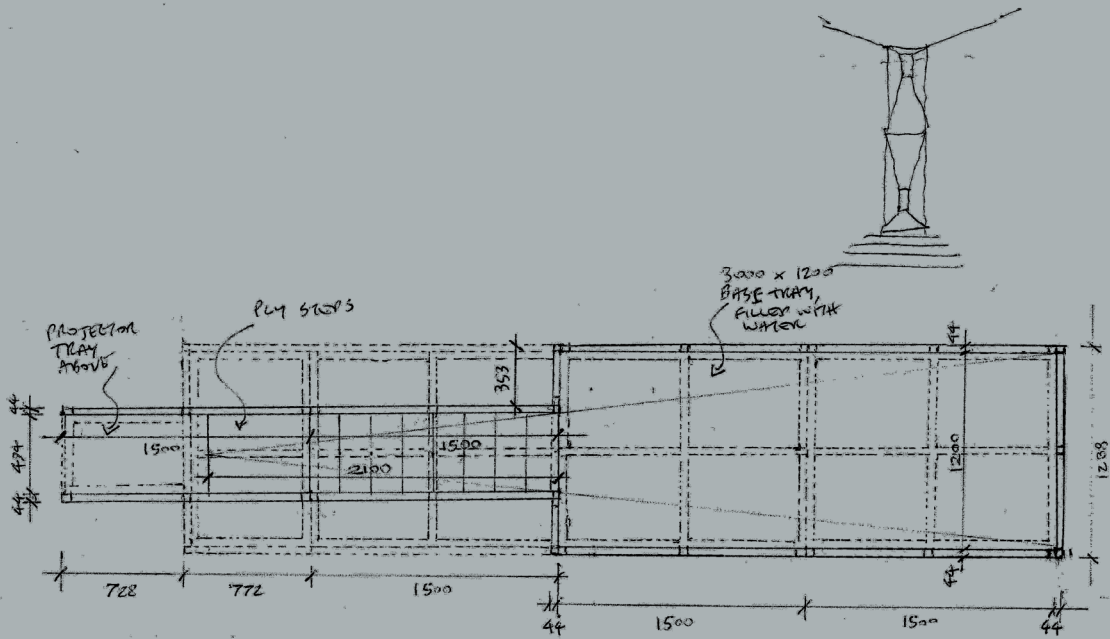

CHAMBER

2005

- Materials:** Canvas, timber, plywood, dvd projection (looped)
- Installation:** Triangle Space, Chelsea College of Art and Design, London
- Fabrication:** Artist, Mick Stickland
- Photography:** Artist
- CAD:** Ge Fei Dong



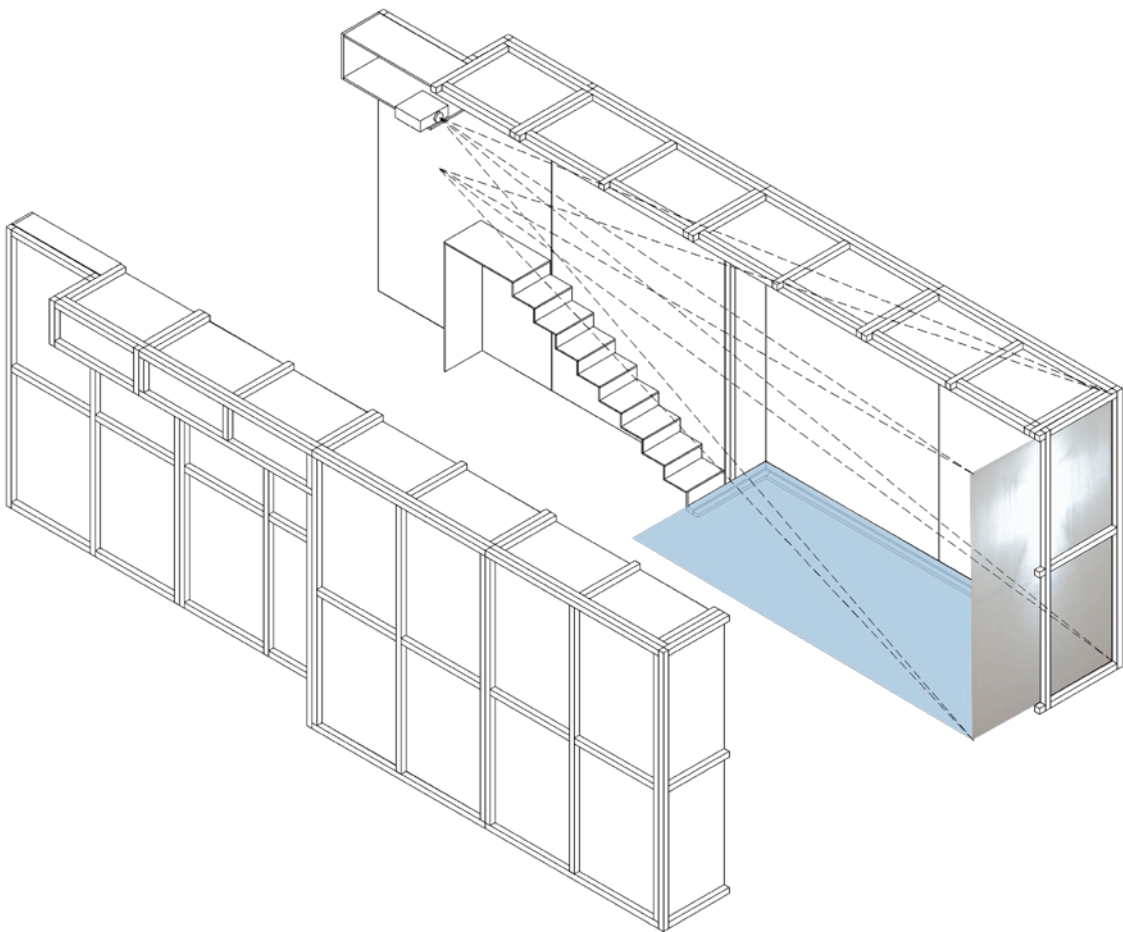
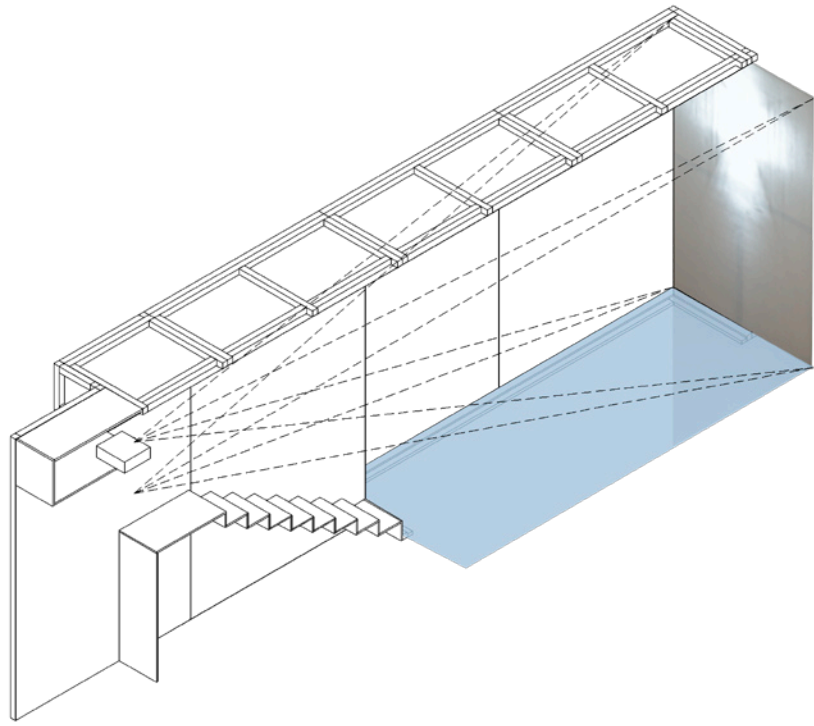





PASSAGE

2006

Materials: Plywood, emulsion paint, fluorescent light
Installation: M² Gallery, Peckham, London
Fabrication: Artist
Photography: Artist





INTERSECTION

2006

Materials: Steel, acrylic, plywood, 2 x dvd projections (looped)
Installation: Triangle Space, Chelsea College of Art and Design, London
Metalwork: Michael Sanders
Photography: Artist
CAD: Ge Fei Dong

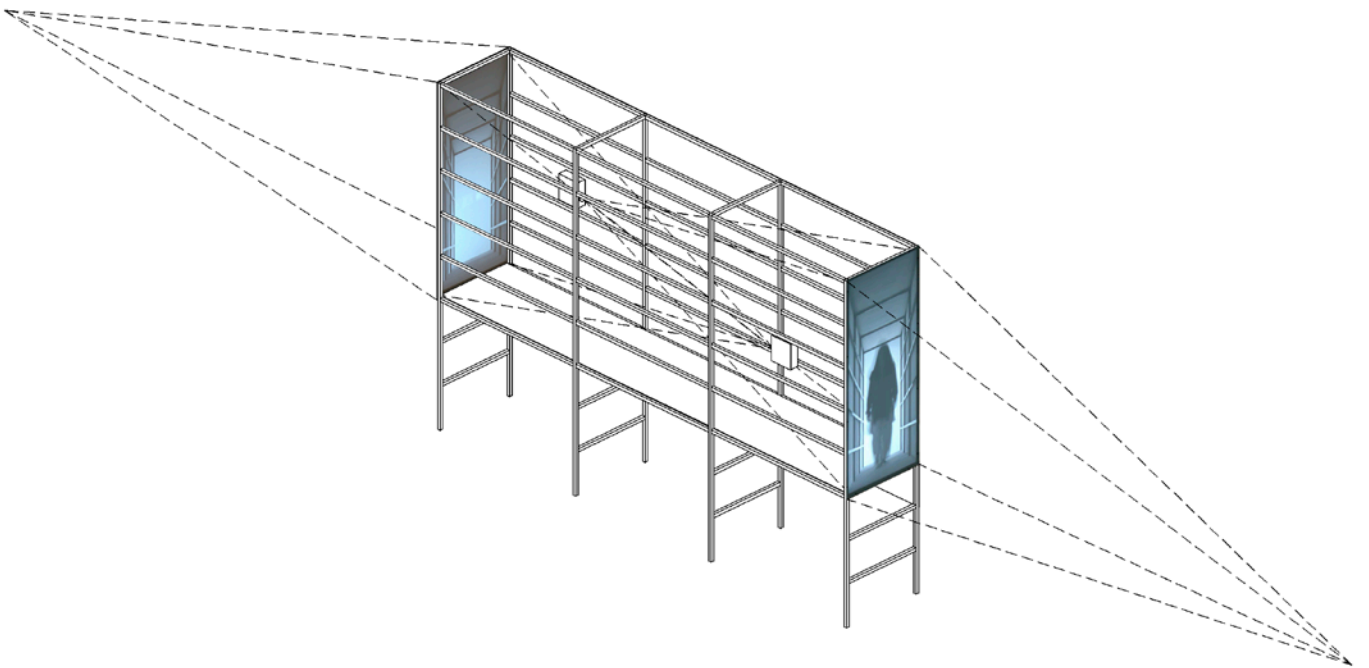
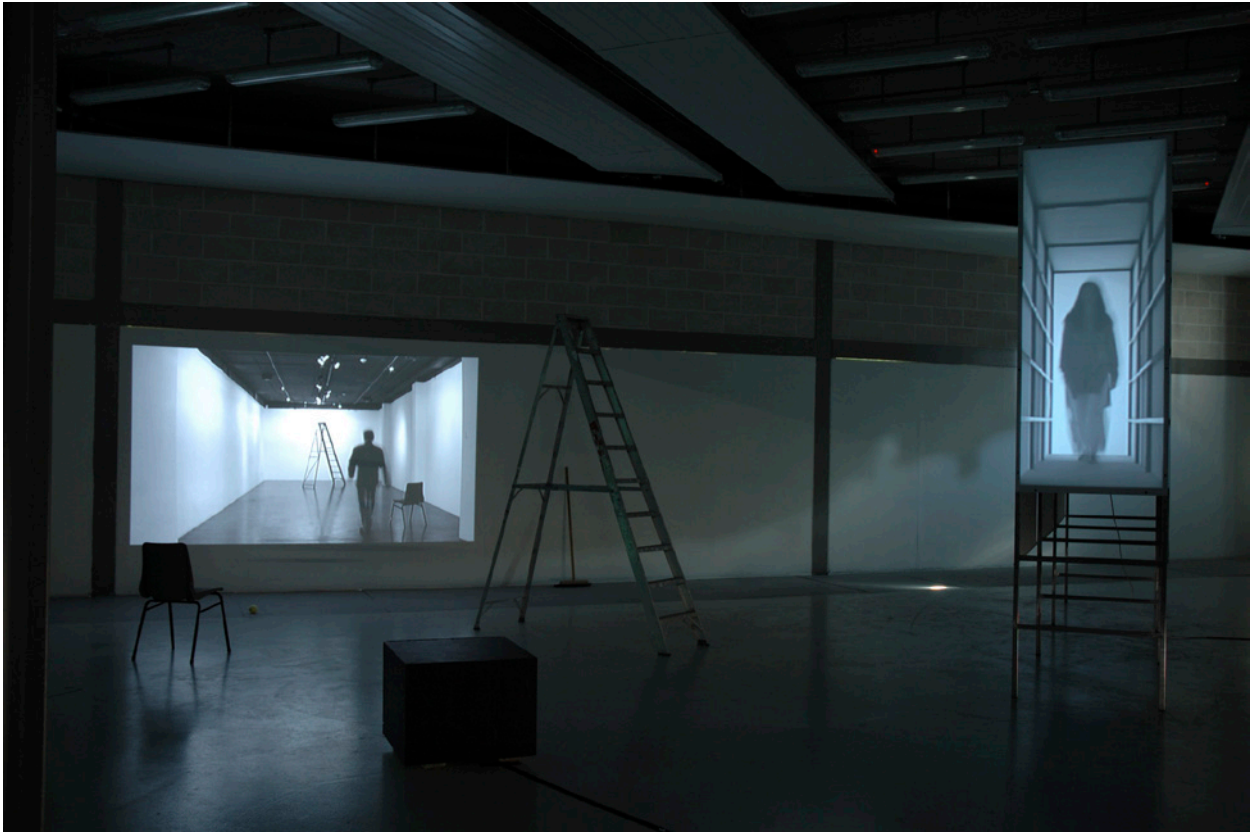

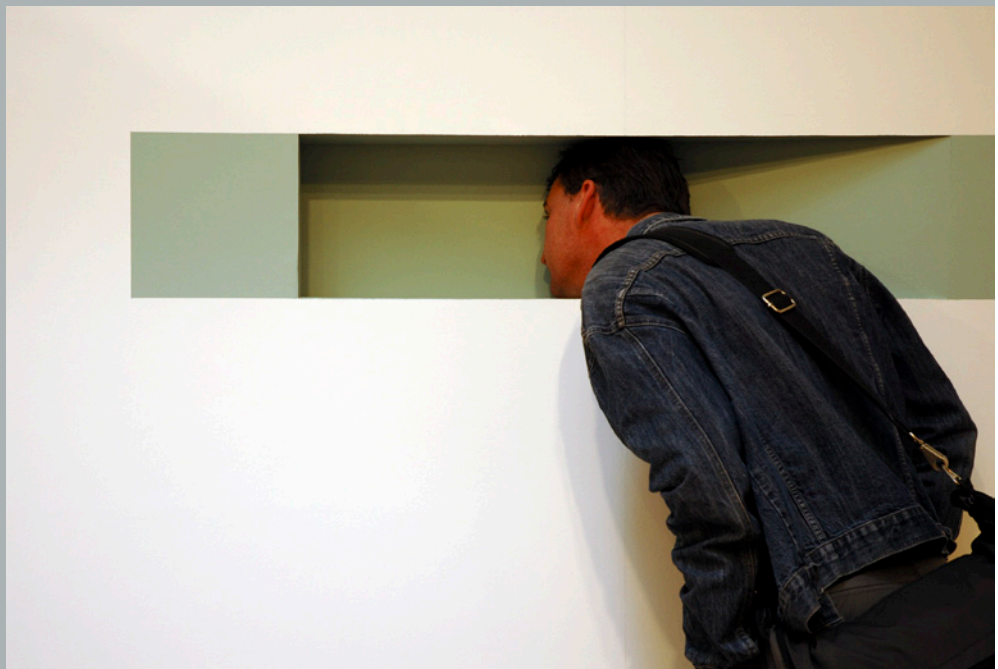

MONOCHROME PASSAGE

2007

Materials: Mdf, emulsion paint
Installation: Lethaby Gallery, Central St Martins, London
Fabrication: Artist
Photography: Artist
CAD: Ge Fei Dong

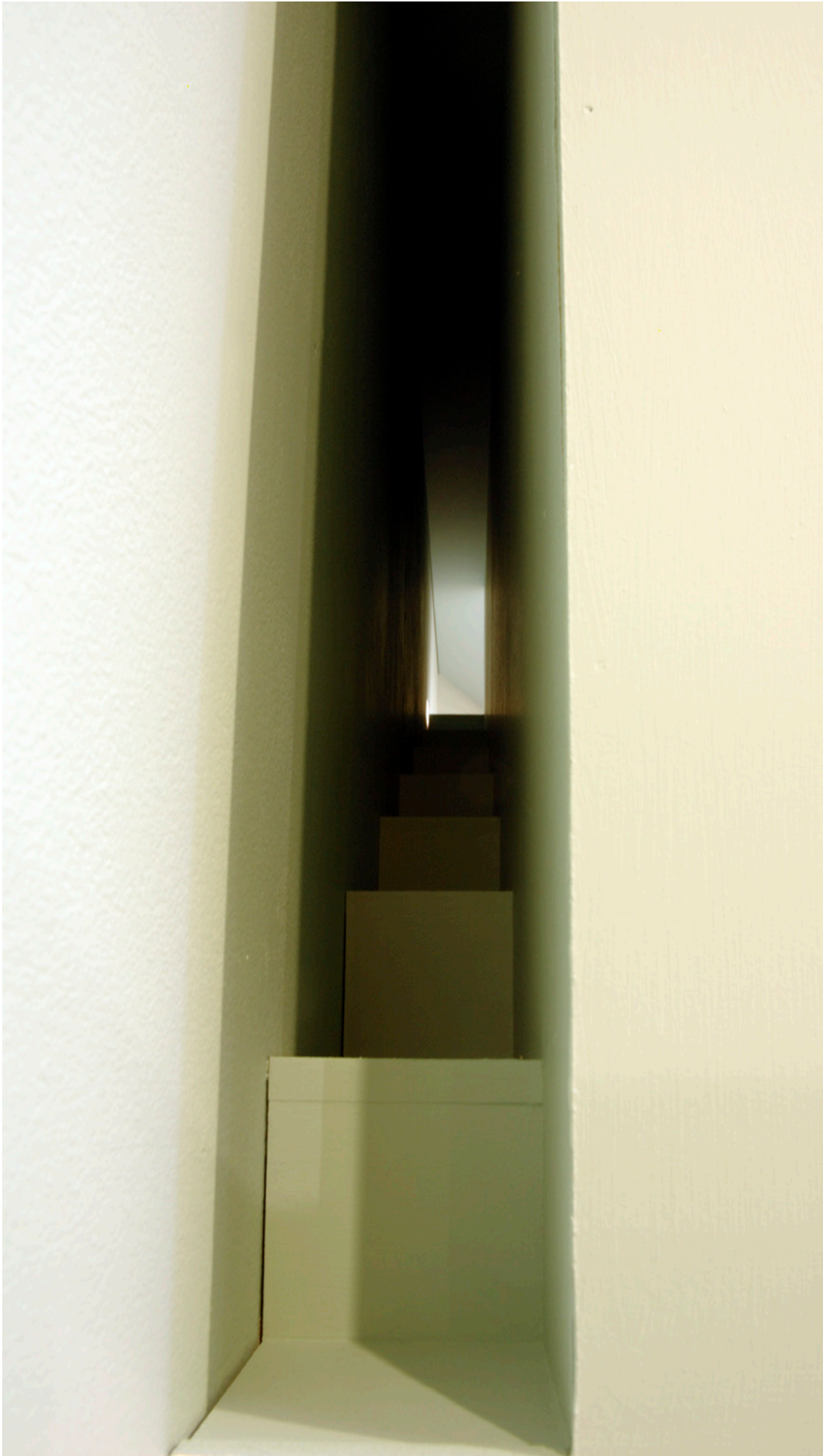

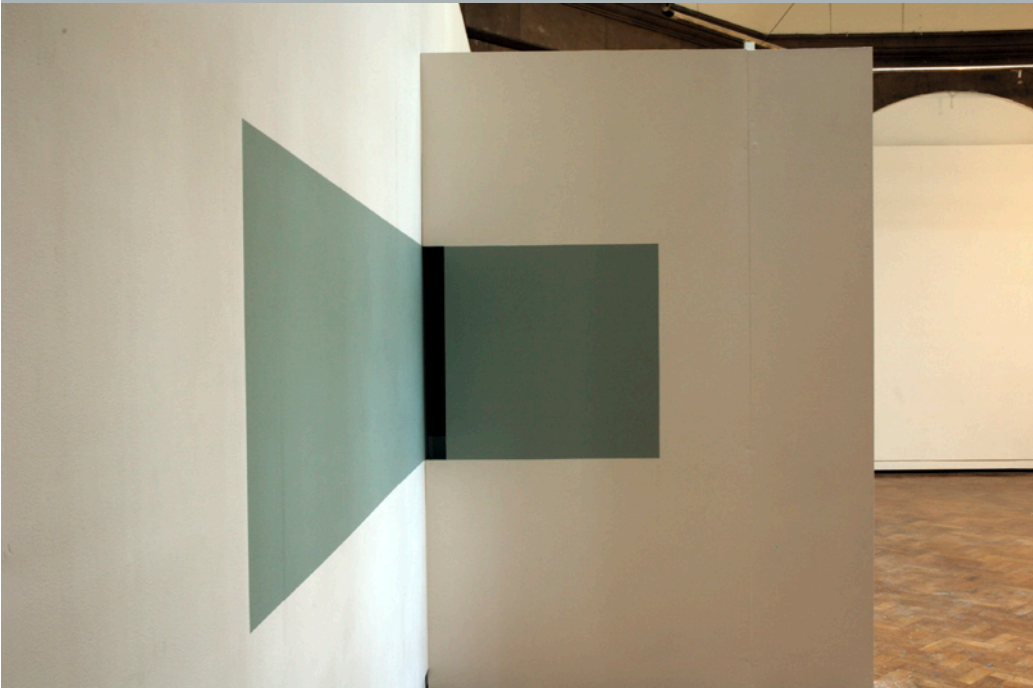
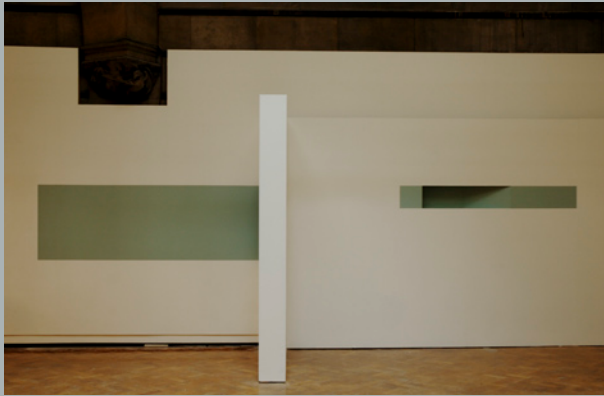
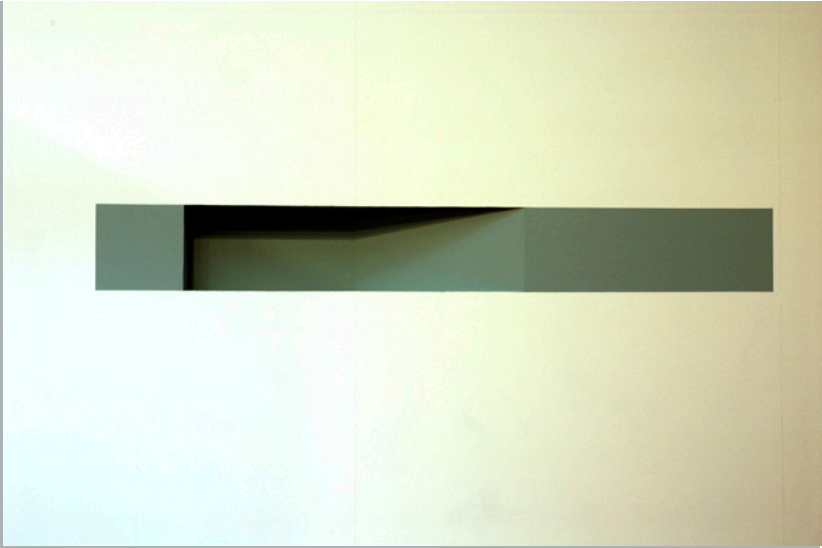

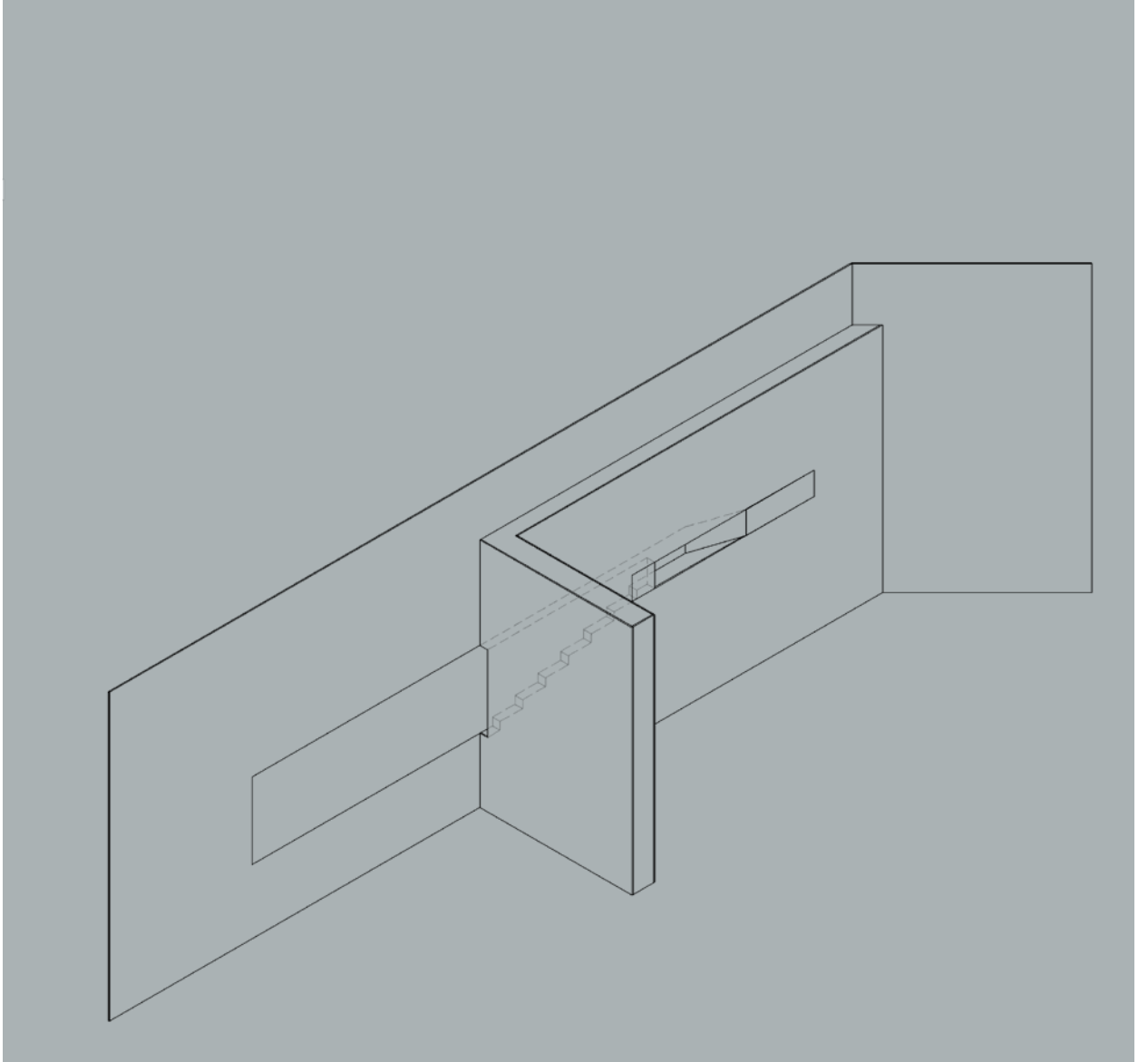

Materials: Plywood, steel, braided cord, emulsion paint
Installation: Banqueting Hall, Chelsea College of Art and Design, London
Metalwork: Michael Sanders
Fabrication: Artist
Photography: Artist
CAD: Ge Fei Dong

