

PEREGRINATIONS WITH MAPS AND LANDSCAPES

Narrating the Spaces of Practice in Fine Art

CHRISTIAN EDWARDES

Thesis submitted in partial fulfilment of the requirements
for the Degree of Doctor of Philosophy (PhD)

University of the Arts London.
Chelsea College of Art & Design.

July, 2015.

ACKNOWLEDGEMENTS

This thesis was only made possible with the support and guidance of my supervisors, my wife, and a those friends and colleagues who have shared their knowledge and advice during the course of this study.

Firstly I would like to express my deep gratitude to my supervisors, Dr. Tim O’Riley, Prof. Stephen Scrivener and Pete Maloney, whose patience, knowledge and continued encouragement provided me with the reassurance that even in the most difficult times, this was a path worth pursuing.

I would also like to thank the research committee at the Arts University Bournemouth for providing the financial support that enabled me to undertake this research, and the university gallery staff who also organised some of the exhibitions in which the artwork was shown. I am also very grateful to Claire Taylor, whose curatorial guidance was invaluable during preparations for *Drawing Lines in the Sand* in Sydney, and Tom Hall and Lee Mackinnon who worked with me on the show *Borderlands*.

Along the way there have also been numerous people who would empathise with my frustrations, point me towards interesting papers and generally offer me their academic wisdom. Colleagues and fellow academics Dr. Candice Boyd, Dr. Alistair Edwardes, David Evans and Dr. Aaron Mcpeake have all played significant roles in pointing me towards enlightening sources of new research, or helping me to get through the viva.

And finally I would like to thank my wife, Anne Edwardes, who has been a constant source of strength when things seemed so overwhelming. She has been the person I could always turn to cheer me up, and to celebrate with when times were good.

ABSTRACT

For some art historians the notion of geography has never had as much importance in art as in recent years. At the same time numerous geographers have been engaged in a diverse range of artistic practices from installation to new genre public art. Often engagements between geographic theory and contemporary art practices are rooted in the peripatetic activities of the mid-century urban avant-garde. Recently, however, artists have been grappling with a number of problems that are distinctly geographic, from studies of place, location and situation to counter-cartographic excursions aimed at reframing our understandings of the world. Yet few of these engagements reflect on the geographies of the studio, or on the constructed situations in which work is created.

Whilst this study begins with an intention to map a series of subject-environment relations in various urban and rural locations, it quickly turns to the complex geographies of the space that is determined as a 'studio' and on the processes of constructing an environment for creating works. The research is rooted in what has been variously termed practice-led, practice-based or simply artistic research. As such research is conducted principally in and through a personal creative practice, but in the course of navigating art-geography relations the research draws on a number of post-representational theoretical strands. In doing so the study navigates between the studio and location, event and representation, in order to show how artworks are implicated in, and co-productive of, nebulous spatial relations that are not enclosed by the surface of the image, the frame of the studio wall or the site of exhibition. Central to this thesis is the argument that artworks remain fundamentally ontogenic—both acting on future works and continuously remade in each reflective revisit.

CONTENTS

<i>Prologue</i>	<i>ix</i>
<i>Introduction</i>	<i>1</i>
<i>Contexts & Methods</i>	<i>13</i>
Turning Practice Towards Research	15
Being in the Middle: Reflexive & Non-Reflexive Moments.	20
Three Movements	31
<i>Walking, Drawing & Map-Making</i>	<i>41</i>
Driving Blind & LOST in Dorset	48
Meeting Place: Contemporary Art and the Museum Collection.	52
Wandering & Desiring Lines	64
Tracing and Assembling	69
Critical Cartographic Perspectives	80
A Swiss Sojourn	85
On Representation	86
Swiss Sketchbooks	97
<i>Islands</i>	<i>105</i>
Polyfilla, Paper and Pins	106
Isolated Chambers, Mobile Sites	112
Studio Movements	125
Intercessions	138

Contents

<i>Home & Abroad</i>	<i>149</i>
Gifts from Australia	151
The World in a Box	166
Gainsborough's "Showbox"	174
Gathering Landscapes	175
Making Landscapes	186
Boxing Landscapes	211
<i>Conclusion</i>	<i>221</i>
Nadir	222

Figures

3.1: <i>55°N</i> , (detail), 2008.	x
2.1: <i>Walking the Dog on Google Earth</i> , (detail), 2008.....	14
2.2: Preliminary tracings for <i>Meeting Place</i> , (detail), 2007.	32
2.3: Pencil sketch for <i>Nadir</i> , 2008.....	37
3.1: Sketchbook drawings made on motorway journeys, 2002	43
3.2: Stills from <i>Driving Blind</i> , 2007.	46
3.3: From the sketchbook <i>LOST in Dorset</i> , 2007.....	47
3.4: Cabinets in the <i>Mikado Room</i> at the Russell-Cotes Museum.....	54
3.5: Ornamental chairs in the Russell-Cotes Museum.	55
3.6: Furniture molding: Russell-Cotes Museum.	56
3.7: Architectural decoration: Russell-Cotes Museum.....	57
3.8, (i-iv): Preliminary drawings for <i>Meeting Place</i> , 2007.	58
3.9: Assembling tracings for <i>Meeting Place</i> . 2007.	70
3.10: Tracings for <i>Meeting Place</i> . 2007.	71
3.11: Objects in the Russell Cotes Museum and Gallery collection	72
3.12: Objects in the Russell Cotes Museum and Gallery collection	72
3.13: Untitled collage, 2007.	74
3.14: Large drawing for <i>Meeting Place</i> . 2007.	79
3.15: Jeremy Wood, <i>Traverse Me</i> . 2010.....	83
3.16 (i-iv): Swiss Sketchbooks, pages from Guarda to Ardez, 2008.	91
3.17 (i-iv): Swiss Sketchbooks, pages from Scuol to Diavolezza, 2008.....	92
3.18, (i-viii): Swiss Sketchbooks, pages from Diavolezza to Chur, 2008.....	94
3.19, (i-iv): Swiss Sketchbooks, pages from <i>LOST in Zürich</i> , 2008.....	98
4.1: Studio test shots for <i>Borderlands</i> , 2008.	106
4.2, (above): Ian Wallace <i>Corner of the Studio I-IV</i> , 1993.....	116
4.3 (below): Ian Wallace, <i>El Taller</i> , 1993.....	116
4.4: Alexander Liberman <i>Mark Rothko</i> , 1964.....	121
4.5: Renzo Piano Building Workshop <i>Reconstruction of the Atelier Brancusi</i> ...	124
4.6: Studio test shots for <i>45°S</i> , 2008.	130

Contents

4.7: 45°S, 2008.....	131
4.8: Studio test shots for <i>West</i> , 2008.	132
4.9: <i>West</i> , 2008.	133
4.10: Studio test shots for <i>North</i> , 2008.	135
4.11: <i>North</i> , 2008.....	135
4.12: 55°N, 2008.....	139
4.13: 23°N, 2008.....	142
4.14: <i>South</i> , 2008.....	143
4.15: <i>East</i> , 2008.	143
5.1: Tea towel given by my grandmother.....	151
5.2: Various tourist tea towels.....	152
5.3 (i-xvii): Studio test shots.	157
5.4 (i-ii): Early attempts to create small vignettes.....	158
5.5: <i>Portland Bill</i> , 2010.....	161
5.6: Studio test shots for <i>Portland Bill</i>	161
5.7: <i>Lulworth Cove</i> , 2010.	163
5.8: Studio test shots for <i>Lulworth Cove</i>	163
5.9: <i>Exports Build a Prosperous Australia</i> , from Gardiner, 1958, p.46	168
5.10: Frontispiece from Sir Thomas More's <i>Utopia</i> , 1516.	169
5.11: Martina Lindqvist, <i>Untitled, Rågskär Island</i> (series), 2008.....	170
5.12: Thomas Gainsborough, <i>Landscape in Suffolk</i> , c.1746.....	176
5.13: Gayle Chong Kwan, <i>New Amazonia, Cockaigne</i> (series), 2004.....	177
5.14: Gayle Chong Kwan, <i>51d32m4sN 0d5m18sW, Veduta Romantica</i> , (series) 2007.....	177
5.15 (i-ii): Early studio shots.	178
5.16 Studio images using found objects from the cellar.	179
5.17 Studio images using found objects from the cellar.	179
5.18: Studio test shots for <i>Travelling Landscape-Objects: The Hunt</i> , 2010.	181
5.19: <i>Travelling Landscape-Objects: The Hunt</i> , 2010	181
5.20: Studio test shots for various landscapes	185
5.21: <i>Untitled</i> , 2010	187
5.22: Studio test shots for <i>The Hanged Man</i>	189
5.23: <i>Travelling Landscape-Objects: The Hanged Man</i> , 2010	191

5.24. Studio test shots of various bought and found objects.....	194
5.25. Studio test shots for <i>Dawn Chorus</i> , 2011	195
5.26. Travelling Landscape-Objects: Dawn Chorus, 2011	196
5.27: <i>Travelling Landscape-Objects: The Old Colonial</i> , 2011	198
5.28: <i>Travelling Landscape-Objects: Woodsman</i> , 2011	199
5.29: <i>Travelling Landscape-Objects: Motherless Foal</i> , 2011	200
5.30: <i>Travelling Landscape-Objects: The Chase</i> . 2011.....	201
5.31: <i>Travelling Landscape-Objects: Young Lovers</i> . 2011	205
5.32 (i-ii): CAD Models for frames.....	209
5.33: Packing instructions	210
5.34: Unpacking and inspecting works in Sydney.	211
5.35 (i-ii): Installing work for <i>Drawing Lines in the Sand</i> , 2012.	212
5.36 (i-iv): Installation photographs for <i>Drawing Lines in the Sand</i> , 2012. ...	213
5.37: <i>Untitled</i> , from the series <i>Dust</i> , 2011	218
6.1: <i>Nadir</i> 2008. Perspex-reverse photographic print.	224

Prologue

The rush of our thought forward through its fringes is the everlasting peculiarity of its life. We realize this life as something always off its balance, something in transition, something that shoots out of a darkness through a dawn into a brightness that we feel to be the dawn fulfilled. In the very midst of the continuity our experience comes as an alteration. “Yes,” we say at the full brightness, “*this* is what I just meant.” “No,” we feel at the dawning, “this is not yet the full meaning, there is more to come.” (James, 1909, loc. 1975)

In the throwntogetherness of a makeshift studio set up in a small shared office-come-studio in North Dorset I am piling bits of torn postcard, polyfilla, an old cigarette butt, and anything else I can scavenge from my immediate surroundings on to a light box, whilst my wife scours the kitchen for old tea leaves, egg boxes and molasses. Minutes later I am arranging these pieces into something that resembles a desert island whilst my wife adjusts the camera and tripod that are inches behind me. We are working together now but I know this improvised studio has also taken over most of the workspace that we share. We take several photographs of the object on the light box and discuss the results. After some rearrangements we take a few more. Negotiating a room that is already filling with the remnants of previous creative ventures, my wife takes the storage card from the digital camera and picks her way through the studio detritus to the computer. She uploads them and opens them into a photo editing programme. We both consider the images again. They are coming together but somehow not quite there yet. She suggests a few more subtle adjustments to the lighting, and I suggest a little post-production work, but then we should be getting close to a result. Much later I am examining the final photograph. The image has the appearance of a desert island set, fairly convincingly, on a glass ‘sea’ against a graduated ‘sky’. I am trying, and failing, to explain how this image tells us something about ‘space’.

Overleaf
Fig. 3.1: 55°N, (detail), 2008.

1. INTRODUCTION



Introduction

How do we conceptualise this dynamic environment in relation to those artistic practices that have traditionally been defined as static, flat and representational, and can they offer alternative ways of approaching image-based practices?

The opening vignette provides an account of some of the fluid and nebulous relationships between the spaces in which image-based artwork is made, those in which it is displayed, and the role of the artist/researcher that make up this study. Rooted in what has variously been termed practice-led, practice-based or simply artistic research, this study maps a series of spatial and material connections in the production of a ‘body’ of drawings and photographic works that attempt to grasp at spatialities of practice.

The text makes use of three exhibitions that occur over the course of the research as a way of mapping the practical and theoretical entanglements by which the question of how art might be used to tell us something about space is turned towards the activities taking place in the studio. Here the focus turns towards the way in which emerging artworks are implicated in, and co-productive of, a set of continuous, dynamic and contingent relations that enmesh, (amongst other things) artists, artefacts, artworks, architecture and guests in continually shifting spatial configurations. Through these the study maps a series of ‘micro-geographies’ (Hawkins, 2014, p.92) that position the studio within a network of other sites and protagonists.

Much of the research ‘material’ comes from these practical engagements, both in the studio and on various sites in which things were gathered and ideas cogitated in the creation of images and artefacts for these three shows. The completed and uncompleted works, written observations and annotations provide the contemporaneous ‘data’ of site and studio encounters, but although individual works might be said to possess a sense of completeness, or wholeness, in their exhibition, central to this thesis is the argument that artworks remain fundamentally ontogenic—both acting on future works

and continuously remade in each later re-visit. They are also considered as both the products and the catalysts for many of the theoretical weavings that evolve in the process of the study—the event-spaces in which works not only emerge, but also are distributed and *re*-produced.

However, in placing my *own* artwork at the centre of this study there is potential for a number of methodological anxieties. Developing research through personal practice means, in this case, an inextricable involvement in the processes and observations that take place. How does an embedded autoethnographic position of artist as ‘researcher’ avoid problems of partiality and questions of critical distance? If the practical ‘outcomes’ of research are conceptualised as vague or indeterminate how are they readily contained within systems of interpretive analysis, or understood as producers of knowledge? And, in the subjective narration of research how does one avoid accusations of narcissism (Holt, 2003; Crouch, 2007)? These concerns are often deeply intertwined with practice-based research methodologies, particularly those where an engagement in the processes of creating artistic material is central to developing insights into the performative and materialist aspects of practice (cf. Barrett, 2010b; Haseman, 2006; 2010). In extending an embedded and processual account of events I will show how a dynamic and reciprocal relationship between practice and theory can be conceived as a valid and productive form of knowledge generation. For this reason the works and the thesis are presented here together as a co-productive endeavour, albeit one that finds a focus on the performance of art-making rather than the *performance* of writing (Pentikäinen, 2006; Engels-Schwarzpaul, 2008).

In the mapping and wayfinding between studio and the writing desk a significant number of artists and theorists have been instrumental in helping to establish the contexts, methodologies and critical dialogues that orientate this research. To briefly map out some of the axes that the research has developed along, a number of writers and philosophers have been central to developing the theoretical component in particular stages of this study. Most of these writers are sceptical of accounts of experience that are entirely grounded in representation, that is, explanations that attempt to fix our understanding of the world as ‘an object and resource for human

Introduction

subjects' (Bolt, 2004, p.12). Instead many of these theorists attempt to capture experience within the 'onflow' of everyday life (Thrift, 2008, p.5) by attending to the way life constantly brings human and non-human elements together in shifting constellations of relation that disrupt easy separations between subject and object, and by turning towards the affective intensities of these relationships. Many, therefore, are also profoundly interested in the materiality of these assemblages, and the potential offered by 'materialist modes of analysis' (Kontturi, 2012, p.19) to move beyond the interpretive paradigms linked to concepts and towards 'the expressive potentialities' of matter (O'Sullivan, 2006, p.4). In this research these are seen in the gathering activities that bring artists, sites and objects together (Bolt, 2004; Hawkins, 2010b; 2014), flow of activities in the studio (Kontturi, 2012; Massumi, 2011; Manning and Massumi, 2014), and in the artefacts that emerge and travel in boxes, on pages or on stretchers (della Dora, 2007, 2009a, 2009b; Kitchin and Dodge, 2007; Kitchin et al., 2009; Larsen, 2014).

At various points in the text the concept of 'assemblage' is used as a means of conveying the dynamic inter-relationships between different elements of an emergent phenomenon, such as the materials that come together in the generation of artwork, or in the relationships between artwork, frame and shipping crate. As a philosophical idea assemblage has been traditionally aligned, (or perhaps mis-aligned) to Deleuze and Guattari's term '*agencement*', (c.f. Phillips, 2006; also Marcus and Saka, 2006; Anderson and McFarlane, 2011), but it is perhaps most clearly articulated by Manuel deLanda (2006) as a means of negotiating problems of scale, and critiquing totalising or essentialising descriptions of society. For deLanda social processes are often reified at two levels, the micro or the macro; the individual or society 'as a whole' (p.30). By conceiving organisations in terms of relations between individuals, objects, artefacts and technical practices that continuously interact, and whose emergence *as* an organisation also affects the interactions of its parts, deLanda theorises assemblages as continuous pulsations between materialising phenomena and their individual components. Similar lines of thinking are traced through this thesis by way of writers such as Nigel Thrift, Brian Massumi and Jean-Luc Nancy, and here are considered with reference

to the coming-into-existence of images and artworks and their subsequent re-organisation as thumbnails, diagrams, instructions, or packages in their distribution.

The disciplinary domains in which these writers work are spread across art history, art theory, philosophy, cultural geography and cartography, but these shared interests that move beyond representational perspectives form the philosophical ‘glue’ that binds them here. However, alongside the work of those theorists noted above are a sizeable body of artists and artworks that have also shaped the way the work has emerged. Some of these form an integral part of the text, like Thomas Gainsborough or Gayle Chong Kwan, others provide markers around which the narrative threads, such as the work of Martina Lindqvist or Richard Wentworth. But the agency of images and artefacts is not limited to those privileged objects that form part of the discourses of contemporary art. Here, the collection of things that effect shifts in the material processes of the studio are as likely to come in forms such as marketing images, souvenirs, postcards, or printed ceramics. In fact it is the very capacity for various images, objects and technologies to activate, shape and become part of the creative event in which these artworks are formed that makes them such an important element in understanding the spatialities of these particular practices.

As the title of this thesis suggests there is a sense in which I travel *with* the evolving works that occur in the rooms of a municipal museum, in the fields of Dorset, on the mountain paths, streets and railways and Switzerland, or in the studios I reclaim in various rooms of the house. This does not mean I relinquish responsibility for, or reject my own agency in, affecting change in the works as they emerge, but equally I do not place myself entirely at the centre of these events—there is no predefined individual subject masterfully orchestrating materials in order to express something. There is a sense of subject-hood that is formed in practice; that acts in practice, but is co-produced and co-productive, that is it involves other objects and individuals in shaping relations, thoughts, and actions in the development of works of art. Similarly, the idea of ‘travelling with’ implies alterity, it suggests companions, or perhaps ‘friends’, to borrow a term from Manning and

Introduction

Massumi (2014, p.64). It is also a nod towards two texts that play a sizeable role in the development of the thesis, art historian Katve-Kaisa Kontturi's Ph.D. submission *Following the Flows of Process* (2012), parts of which have been republished in Estelle Barrett and Barbara Bolt's *Carnal Knowledge* (2013), and Veronica della Dora's 'Travelling landscape-objects' (2009b). Both of these have helped in orientating different stages of creative work, although neither is used as a conceptual framework for creating or interpreting the works, rather they are debates that have journeyed alongside phases of making and writing. Both, however, share an interest in matter and materiality *in movement* (Kontturi, 2012, p.26), and in accounts of experiencing images and image-making that attend to the substances which form and support them (della Dora, 2009b, p.335). Furthermore, both are sceptical of purely iconographic readings that present images as texts to be decoded. Whilst this thesis shares a curiosity in the fluxes and flows of matter it approaches image-making from the point of view of the artist-practitioner, and in doing so brings a parallel understanding of the pulses of experience in the event of practice.

Whilst the thesis primarily draws on philosophical and geographic conceptualisations of spatiality, threaded through the thesis are a number of writings by artists who approach these notions with a distinct interest in the way they support practical and creative activities, artists such as Barbara Bolt, Maryclare Foá and Ian Wallace. The writings of these particular practitioners are often used in this thesis to extend or contrast the progression of ideas within the text. There are a sizeable number of artists who situate their practice in relation to geographic concerns, and many of these artists are identified by geographers, art historians and theorists as offering alternative ways of experiencing, say, site, location and landscape (Cant and Morris, 2006; Watson, 2009; Hawkins, 2013). Arguments presented by artists themselves are less abundant, although there are some notable exceptions. Publications by artists *about* artists, such as Jeremy Millar and Tacit Dean's (2005) *Place* provide useful accounts of how practices and outcomes might be organised into spatially-inflected categories. But although these curatorial arrangements provide useful structures through which art works can be aligned to debates that emphasise particular spatial tensions, they provide

less of an insight into the spatial dimensions of *art-making*. Artist-researchers such as Andrea Thoma (2006), Maryclare Foá (2011), Amanda Thompson (2013), Ian Kiaer (2013) or Annette Keirulf (2015) have endeavoured to root the making of work within space- or place-based arguments. Some of these practices (Foá, 2011; Thompson, 2013) make use of peripatetic performances, photographs and tracings that create connections to landscape, and draw on theoretical discourses that illuminate a series of interdependencies between artist-participant and environment. Others explore these relations in more proximate spaces, such as the studio or home (Thoma, 2006; Wallace, 2012; Kiaer, 2013; Keirulf, 2015). This thesis acknowledges these existing propositions and also builds on them by following a flow of events that begin in a series of correspondences with locations, but trace some of the observations that come from these through the studio and on to the spaces of exhibition and circulation. In doing so I begin to forge particular conceptualisations of the environments in which work is made. In the text I have tried to maintain some sense of the messiness of artistic activities in each phase of the research as a means of illustrating some of the uncertainties of practice. This text brings these often diverse and various accounts together in order to address a number of research questions that build through each phase of study: How can a practice-led investigation offer alternative ways of reflecting on the contingent and dynamic nature of spatial experience? How might relational understandings of space, and recent writings on the performative nature of artistic production form new approaches to thinking about the porous boundaries of the studio, the contingent and collaborative nature of artistic production and the ontogenic nature of artworks? And in thinking about the production of artworks in spatial terms, how do we account for the material constructions that enable their distribution: the frames, boxes and crates that enable them to travel, the images and documents and other references that circulate with them and authenticate them as works of art? Might these be productively understood as spatial arrangements that also extend and blur the limits of the ‘work’? If this research can be described as being directed towards a particular audience, it is, perhaps, those arts practitioners who have an interest in capacity for works not just to direct attention to perceived spatial

Introduction

problems, but also to be recognised as already caught up in a continual and nebulous space of potentialities—to be both the ongoing product of spatial relations *and* a part of their continuous production.

To attend to these questions the thesis is aligned to three phases of artistic productivity, where these various speculative turns play out against attempts to form meaningful artworks that are either allied to, or parallel these spatially-related questions. To begin with the study looked for a series of strategic formulations of creative production that might elucidate or reflect on a perceived set of tensions between different *qualities* of space. These quickly became mired in a perpetual collapse between the observing, performing artist and the continuum of newly forming relations that resisted the abstraction of space into a neat object-like form. Such methodological difficulties and evolving perspectives are outlined in Chapter 3, which follows the development of a number of cartographically-orientated artworks largely produced as drawings made whilst travelling either on foot or by train. The attempts to map a series of relationships between this travelling body and a number of proximate entities (for example, the edges of buildings, tables, paths, dead animals) are considered in relation to two strands of cartographic thought, one from the visual arts and the other from the field of critical cartography. A brief history of recent artistic map-making practices also outlines some of the counter-cartographic movements aimed at contesting the implied objectivity of maps or critically revealing their hidden power geometries. This is contrasted with theoretical developments over the last ten years within critical cartography that seek to overturn the ontological certainty of maps as simply representational entities by considering them, instead, as practices; as emergent, (and as such constantly under revision each time they are brought into new sets of relation with human and non-human agents). By bringing these three strands together this chapter sketches out a repositioning of the initial research ambitions in terms that are sceptical of neat separations between subject and object. By thinking, instead, about the way the event of practice involves a continual shifting of identity between what is understood as subject and object, new conceptions of space begin to emerge. Attempts to establish positions in relation to a space ‘out there’ fall

back on the performative aspects of artistic activities, the *doings* of making and the role these play in shaping spatial experience. These acts of performing the drawings either ‘on site’ or in the studio are also ruminated on in relation to the vitality of the gesture and its subject-forming potential through the writings of Tim Ingold and Jean-Luc Nancy.

This account sets a basic theoretical framework for the chapters that follow. As the research progresses and more eventful accounts of space emerge, attention turns towards the way in which the artistic activities are themselves spatially productive, and in doing so the research begins to ask questions about how these relational and non-representational apprehensions of space provided new ways of considering the activities of artistic practice. It is a shift directed more specifically to thinking the activities of practice in spatial terms, and Chapter 4 is staged in that pre-eminently privileged space of artistic production—the artists studio. Again, the chapter draws together historical and philosophical discourses on the space of the studio and reflects on these alongside the acts of creating of my own practical works. But whereas in the initial stages of the research the environment in which practices took place was firmly identified as the object of study, here an expression of fixed limits between the space in which practices occur, the architects, materials and outcomes of those practices are brought into contention. Relational arguments for space by geographer Doreen Massey and observations on creative practitioners at work by Katve Kaisa-Kontturi, Erin Manning and Brian Massumi provide the epistemological grounds for exploring the contingent and volatile constructs of the studio. These writings parallel the creation of a series of photographic works, island-like formations that draw in matter from the studio, then various other rooms in the house. As the acts of making take up processes of preparation, selection, composition, capture and editing the boundaries between the studio, the work, and the various elaborate constructions that enabled the creation of images became increasingly blurred. So too does the sense of an autonomous author or determinant outcome, as the matter, the visitors and the emerging images and artefacts that become the environment of the studio, act on successive phases of creation. This chapter progresses an argument for the studio as emergent,

Introduction

mutable and entirely porous; one cut through by a multitude of forces that both shape the limits of the studio and the work, and also constantly disrupt them.

The following chapter takes this threshold further, tracking the journeys of the works as they leave the studio in frames, boxes and crates to be installed as part of the exhibition *Drawing Lines in the Sand* in Sydney. The photographic images that develop in this phase of creative activity are constructed from knick-knacks, souvenirs and other found objects to form images of landscapes. Many of these objects are selected because they already carry images of landscapes on their ceramic surfaces, or contain scenic models within their glass structures. This chapter follows a series of performances—gathering, constructing, framing, shipping and displaying—that extend the limits of what is identified as the ‘artwork’ from the production of a singular artefact to its continuous re-construction as a series of assemblages, which not only provide the means for recognising its existence as a work but also provide a means of mobilising and distributing it in varying new and alternative forms. Like previous chapters the arguments that are progressed here draw on a number of differing sources that examine not only the materiality of these landscape-images, but also the way in which they are mobilised. The writings of art historian WJT Mitchell and cultural geographer Harriet Hawkins help to conceptualise the performance of finding and gathering, whilst those of Veronica della Dora offer a hypothesis for considering the circulation of art objects as assemblages encased in frames and crates, and travelling alongside official paperwork, thumbnail images and installation instructions.

As the text progresses there is a progressive blurring of boundaries that might neatly distinguish the artwork from its spatial origins, or that distinctly mark it out from other structures that contain it, enable it, or authenticate it. The photographs that run together here alongside the text are often similarly diffuse. In the early phases the images that appear in this thesis provide records of drawings or other works that exist in media other than photography, images such as fig. 2.3 (p.37) or fig. 3.13 (p.74). Here the use of photography provides a means inserting into the text visual materials that exist in other forms too, such as in sketchbooks. That they are presented in the thesis as

photographs changes not only their materiality, but also the relationship they have to each other in the books they were drawn in, they become both representations of drawings that exist in another form, and presentations of a movement of thinking that is structured in relation to the text. In some cases the photographic images were originally intended as reference material, for example: fig. 3.4; fig. 3.11 or even fig. 5.9, (pp.54, 72 and 168 respectively), pictures that were later used in the production of drawings, tracings and later photographic works. They are reproduced here in such a way that the reader begins to relate points at which reference material gets taken up into drawings, collages or photographs. And as photography also becomes the medium through which the works are created and presented there are an increasing number of images that also tell of the processes of gathering, assembling and cogitating, but also of the potential for alternate endings. The images of propositional ideas, or ‘studio test shots’ such as fig. 5.3 or fig. 5.20 (pp.156 and 184) are less indicators of teleological developments towards a pre-imagined goal than indicators of numerous virtual existences—new prospective ‘lines of flight’. Where the images are presented as titled works such as *45°S* (fig. 4.7, p.131) or *Travelling Landscape objects: The Hunt* (fig. 5.19, p.181) they provide images of the photographic works that were usually presented for exhibition, or at the very least became the point at which one phase of a process arrived at an apotheosis before moving on to the next, such as relationship between fig. 5.3 (p.157) and *Portland Bill*, (fig. 5.5, p.161). The images, however, like those from the sketchbooks, are also remade here for the purpose of elucidating the text. They are rescaled, titled and given reference numbers that enable a different set of relations to develop within the conventions of writing than those objects that travelled to Australia, for example. From the work in Sydney another series of images emerge, those that record the installation of works on Cockatoo Island such as fig. 5.34 (p.211). These provide a means of illustrating a narrative of travel—of packing and unpacking, labelling and exhibiting, and of showing new relationships develop in relation to the site, the ground, the signage, the preservation and arrangement of these objects.

This first section has provided a general overtone for the text that will

Introduction

follow. In the next chapter I provide a more detailed context that describes approaching practice-based research, and sequence of occurrences that become the structural fabric of its retelling.

50° 54' 04.35" N

2° 14' 58.96" W

2. CONTEXTS & METHODS

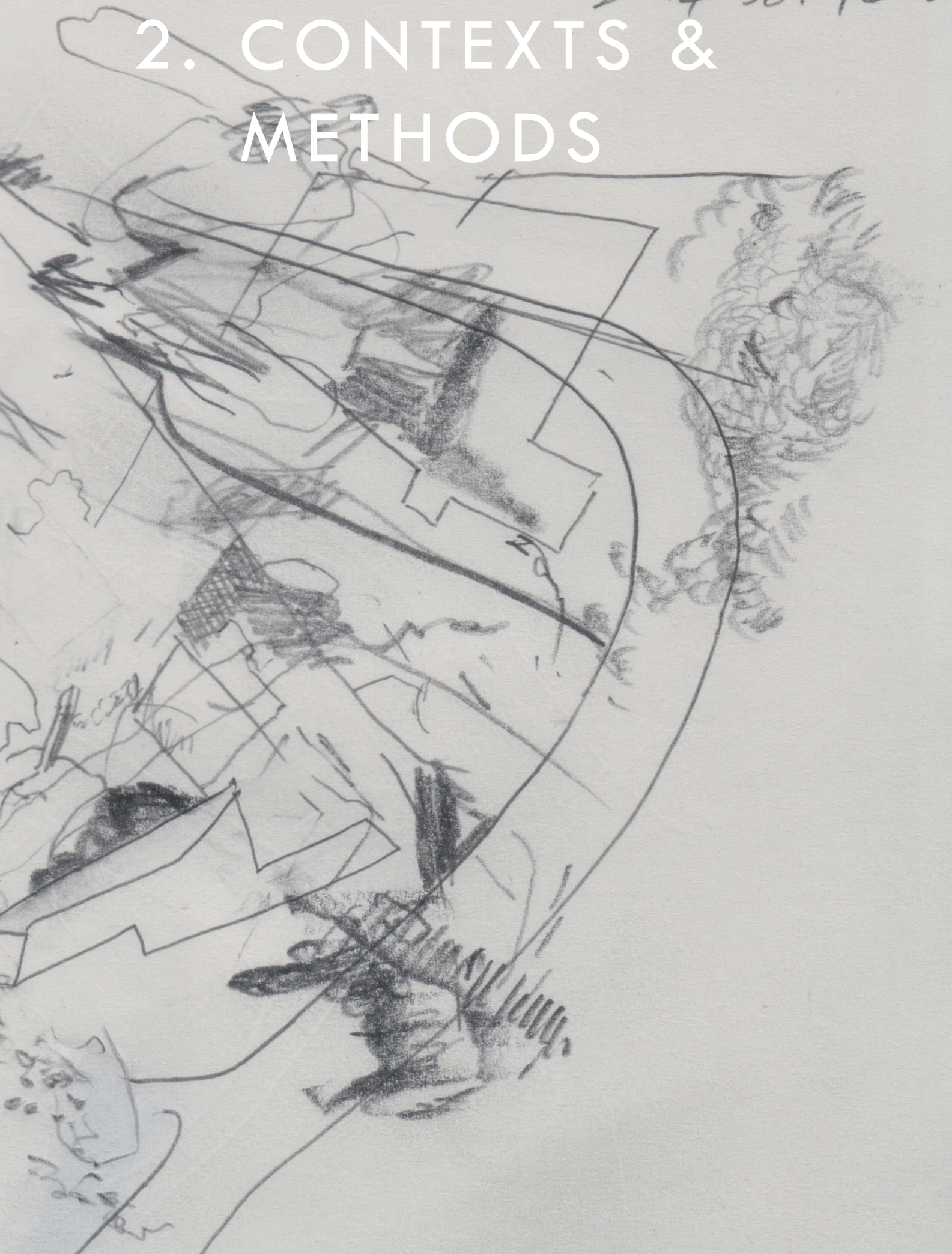

Contexts & Methods

In the following chapter I lay out some of the debates around practice-based research that were circulating at the beginning of this study, and some of the movements that began to orientate the research. I explore some of the questions surrounding the role of artist as practitioner *and* researcher, along with some of the frictions these questions precipitated. Many of these were orientated around fears that arts practitioners writing about their own practices would be unable to achieve sufficient critical distance from their research, leading to excessively subjective, perhaps even ‘narcissistic’ writing (Holt, 2003; Crouch, 2007). These concerns were often aligned with calls for greater reflexivity, a need to distance researcher from the activities of practice. I consider how these worries might be connected to model of empirical research in which the observing subject and observed object are idealised, and by turning to the work of sociologists Micheal Lynch and Karin Knorr-Cetina and geographer Nigel Thrift, examine recent discourses that attempt to express the unpredictability of practice and of the research environment.

Finally I outline the three phases of study which form the backbone of this research, expressed here as three movements. Whilst they possess some suggestion of beginning and ending, I propose that these are considered not as discrete ‘case studies’ but as pulses of practical and theoretical interaction that act on one another, and in doing so propel ideas forward.

Previous Page:

Fig. 2.1: *Walking the Dog on Google Earth*,
(detail), 2008.

Turning Practice Towards Research

...an island lay over there, or perhaps a continent. What it was he did not know, for colours depend on the object that affects them, on the light that is refracted in them, and the eye that fixes on them, thus even the most distant land appeared real to his excited and afflicted eyes, in their transient marriage to that light, to those winds, and clouds. Perhaps tomorrow, or in a few hours' time, that land would be different. (Eco, 1998, p.66)

A number of existing practice interests were instrumental in the geographically orientated origins of this study. The works I had created prior to this research, that is, those that had developed from post-graduate study and professional involvement were less directed towards and specific set of problems than a set of elliptical 'interests' generated around place. These would often use landscape images or models to work on connections between the quotidian and the utopian, for example, by associating habitual practices such as smoking and idealised images of contemporary housing developments. These historical practices are not unimportant, since, as this study will show, much of the work that evolves in response to the practical and theoretical challenges of the research retains some sense of a body of work already in flow. However, in order to see the work as research, rather than simply the reiteration of previous creative processes, it is useful to understand this study as a process of discovery in which approaches to both practice and theory are continually repositioned in relation to occurrences in experimental environments of the 'studio', 'site' or at the writing desk.

When this study began, debates around why fine art practitioners might enter into research, or indeed what research could do to the future of arts practices, were still fraught with a certain resistance to notions of the 'academisation' of the arts (Borgdorff, 2012, p.32). Artists and critics, including John Baldessari and Michael Craig Martin, voiced open incredulity to the idea of artists undertaking PhDs (Madoff, 2009, p.45), and as a recent series of exchanges in the letters pages of *Art Monthly* show, anxieties over fine art and doctoral research still continue (Suchin, 2011; Burgin, 2011;

Price, Everall and Fusco, 2011; Charlesworth, 2012; Suchin, Cillam and O’Kane, 2012). Whilst there is significant argument about how practice-based research might be understood as research, and the different modalities of research used by practice-based researchers, questions around why artists might undertake research at doctoral level are (on the whole) less evident.

For my part, the idea of turning an on-going ‘professional’ practice towards research seemed, at first, to be a simple reiteration of existing practical activity towards a broad interest in geographic questions around place and space, perhaps with the idea of adapting my existing methods of making artwork with these notions framed as the *problem* to be investigated. Initially, less attention was given to the way in which these constructed situations that I intended to use to reveal something about the terms space and place, also involved complex spatiotemporal arrangements of bodies, matter, and forces. But as the activities of making artworks began to have an increasing effect on descriptions of ‘research’, the composition of the environments in which work was made (and distributed), began to bring to the fore unexpected questions about what I meant by (a) practice and, by extension perhaps, *practice-based* research. These shifts in understanding were often concentrated at points where there appeared to be the sharpest divisions between an existing ‘professional’ practice and one that directed towards a defined research problem, most notably in the attempts to establish theoretical frameworks for phases of practical output that culminated in exhibition. Here the exhibitions themselves were not the goal of a phase of research, but became points of rumination and discussion. They became moments at which I would shuttle between reflections on artworks arriving at a point of apparent consummation, and a growing acquaintance with a body of spatial thinking. In this dialogic interweaving there is both a prehistory and an anteriority to the relationship between the work and the text, that is, a sense in which I am both ‘coming-to’ the research and ‘moving through’ it, shifting positions in the process. As the events of practice become enmeshed with those of theory-forming, they too become ‘objects’ of research, the matter from which new formulations and directions for research emerge.

When Katie MacLeod examines the functions of written text in practice

based PhDs, she observes three particular distinct relationships between text and practice:

...type A which is defined as positioning a practice; type B defined as theorising a practice and type C which has been given the in-progress definition of revealing a practice. (MacLeod, 2000)

Whilst one might question whether these functions of the text are as discrete as is initially suggested, MacLeod's identification of three 'types' of approach to research practice appear to suggest some of the ways in which the research text locates, frames, or forms through practice. In these cases the function of the text serves to either position, theorise, or reveal the practice. In 'positioning a practice', (Type A), MacLeod points to the use of text as offering cultural or historical markers through which the identity of the artist and their approach to making can be located. Yet it is clear that text not only informs but in some cases alters or 'renews' practice. Similarly in 'theorising a practice' (Type B) a conceptual framework is developed by which the researcher is able to make comparisons between philosophical propositions and the application of practical methods. The process of creating work is then considered within a specific theoretical structure. The final example, the 'in-progress... revealing a practice' (Type C), text and practice unsettle one another in iterative phases:

...what fascinated me about this type of research was the seesaw effect of working on the written text and on the art projects... after the completion of one phase of the written text, when the seesaw was high in the air, the ensuing work on the art project would destabilise what had been achieved to the point that when the researcher returned to the next phase of research on the written text, the seesaw was firmly down on the ground and the text had to be completely reconceived; when the next phase of research on the written text was completed and the seesaw was high in the air, it was only to descend again when the work on the ensuing art project was underway. Thus, the written text was instrumental to the conception of the art projects but the art projects themselves exacted a radical rethinking of what had been constructed in written form because the process of realising or making artwork altered what had been defined in written form. (MacLeod, 2000)

In this example acts of creation through text and practice are in a repeated contrapuntal relationship, neither forming an exact fit with the other as the event of writing gives way to the event of the next art project. As MacLeod later acknowledges, these ‘types’ of research overlap, although with limited details on individual projects it is difficult to get a picture of the different forms of negotiation between practice and theory. However it is the form of the final research submission that concerns MacLeod, and in this description of research that continually oscillates between the text and the artwork that she finds the most empathy.

A similar iterative representation is also at the centre of Hazel Smith and Roger Dean’s introduction to *Practice-Led Research, Research-Led Practice In The Creative Arts* (2009), a model that, like MacLeod’s, follows a shuttling back and forth between academic research, practice-led research and research-led practice. Both these models attempt to show how material produced in one domain, either in practice or in research, can be used to counter-balance or disrupt material from another, and how both are co-dependent in forming research outputs, either as texts or visual works. Yet both these illustrations raise concerns about the construction of a knowledge object and a research environment. First is the way in which theoretical and practical cycles of research appear to form knowledge objects that can be selected and tested in relation to extant research. The second is the way in which these distinct phases articulate the particular structures in which this speculative knowledge-object is (in Dean and Smith’s example) ‘developed’, ‘synthesised’ and ‘interpreted’ (p.20). In more simple terms, how do ideas (and objects) emerge from the event of research work? How are they conditioned by, or indeed condition, the research environments from which they ‘emerge’? And what happens to the synthesised remains? Are they taken up in subsequent iterations of this experimental process? In this study both the event and the situations in which, or through which, practice-based research ‘happens’ have become pivotal to developing the broader spatial themes within the thesis. In a sense it the ethnomethodological flavour of a “study in (one’s own) creative processes” that theorists like Søren Kjørup (2010, p.28) have called for.

The study is narrated around three practical phases, which often correspond with the preparations for and exhibition of a series of works. Yet even in writing this I hesitate in describing the flow of works into neat circumscriptions of project beginnings, middles and ends, so I offer the caveat that these are described in three phases not because they possessed a discrete order, but because it is useful to think of their movement in this way. And it is useful to think of it this way because at the close each begins to *feel* like the consummation of one movement even as the next phase takes its material up again to generate new forms. Each phase follows a qualitative flow of action from the conditions that precede a creative process, to the emergence of a dynamic *semblance* of experience. That said, ‘storying’ the research in this way also risks a certain teleology, and, given the autobiographic disposition of these accounts of creative practice, has the potential to provoke accusations of overly subjective, or even narcissistic, writing (Holt, 2003, p.19; Crouch, 2007, p.106). This is something I will turn to in the next section.

Looking back these three group exhibitions can be seen as markers between which practical and theoretical developments can be navigated, and so the works produced leading up to, and following on from these exhibitions are examined in relation to a emerging shift in my own understandings of spatial theory, even if many of the works were never finally shown. These three exhibitions were periods of intense practical activity that often bifurcated into very different strands of artistic reasoning. At the outset the concerns were directed towards positioning the artwork in relation to potential research ‘strategies’, and these were often founded on conceptualising creative activities as ways of generating visual ‘data’—making drawings, video and audio recordings, tracking movements using Global Positioning System (GPS) devices, for example. As these works were being produced a number of theoretical problems around spatial representation were also being identified, and yet often these theoretical developments seemed to be at odds with my own sense of what the works were doing. At times it became difficult to explain how the static outcomes of practice elucidated increasingly dynamic and contingent understandings of space, or how a developing body of theoretical work might help to consider the images being created. It took some time

before a connection was made between the ideas developed through research and what was going on in and outside the ‘studio’. And yet each practical phase was being shaped by emerging theoretical questions, just as each new return to discourse was influenced by concerns that arose through creative activities. As the research progressed it became increasingly important to consider the act of creating works and not simply the interpretation of their outcomes.

Being in the Middle: Reflexive & Non-Reflexive Moments.

We ground things, now, on a moving earth. There is no longer any place of overview (mountaintop) from which to map human ways of life, no Archimedean point from which to represent the world. Mountains are in constant motion. So are islands: for one cannot occupy, unambiguously, a bounded cultural world from which to journey out and analyze other cultures. (Clifford, 1986, p.22)

Winding between and moving alongside the events that unfold in the studio, or in those locations I find myself making artworks, are periods spent at the writing desk or in the library. Here I pick apart and reconstitute assemblages of images and text that sometimes seem to situate, sometimes collapse and sometimes accelerate, my own artistic and theoretical understandings of space. Articulating these events originally took place in the periods between immersions in the process of making, but since then much of the research ‘journey’ has also been reviewed and revisited as the acts of artistic creation become re-enacted within the narrative of research.

The issue of narration is significant in this study, since it rests both on the idiosyncrasies of a self-authored arts practice, and in doing so connects to a number of autoethnographic approaches within qualitative research. Broadly speaking autoethnographic accounts emphasise, variously, the research process (graphy), culture (ethnos) and the self (auto) (Ellis and Bochner, 2000, p.740), and grew from a postmodern disenchantment with the claims for certain kinds of ‘truth’ that were tied to scientific master narratives (cf. Latour and Woolgar, 1986; Latour, 1988; Kuhn, 1996). The shift of critical emphasis towards the author, the audience and the vocabulary

used, was a means of debunking assumptions of research objectivity and neutrality by accommodating the identity of the author, their subjectivity and emotionality, rather than hiding their influence on the process (Ellis, Adams and Bochner, 2011). Sociologist Patricia Ticineto Clough (2000) even describes autoethnography as ‘the most developed form of experimental ethnographic writing’ (p.279), but whilst it has become a significant element in contemporary ethnographic method (Ellis and Bochner, 2000; Holt, 2003; Gannon, 2006), some are still cautious about the use of personal testimony that is not also supported by ‘hard’ evidence, for example in the form of notebooks, photographic records, audio recordings, or externally created reports, (Duncan, 2004; Muncey, 2005; cf. Wall, 2008).

For a study that centres on visual arts creation as an essential aspect of the research, subject/object separations are highly problematic, especially when the narrator is so deeply embedded within the event of practice. Art theorist Henk Borgdorff (2012) draws three clear distinctions between research practices within the arts: research *on* the arts; research *for* the arts; research *in* the arts, a notion that, perhaps, derives from Christopher Frayling’s paper on ‘Research in Art and Design’ (1994, p.5). For Borgdorff research *on* the arts is characterised by having arts practice ‘in the broadest sense of the word as its object’ (p.37), whereas research *for* the arts is described as applied research that ‘provides insights and instruments that may find their way into concrete practices’ (p.38). Research *in* the arts involves the articulation of embodied knowledge through the creative process, and the in the artefacts that are produced as a result.

Research in the arts is the most controversial of the three ideal types... I earlier described this approach as the ‘immanent’ and ‘performative perspective’. It concerns research that does not assume the separation of subject and object, and does not observe a distance between the researcher and the practice of art. Instead, the artistic practice itself is an essential component of both the research process and the research results... Concepts and theories, experiences and understandings are interwoven with art practices; and, partly for this reason, art is always reflexive. Research in the arts hence seeks to articulate some of this embodied knowledge throughout the creative

process and in the art object. (Borgdorff, 2012, p.38)

It is, therefore, difficult to escape some level of autobiographical description if we are both explaining a series of actions we are performing and then looking for why these might be happening by turning on the situation and intentions of the performer (Stewart, 2003). But the text does more than simply describe or explain the actions of a visual arts practice; it also reinvents them. The post-hoc explanations of studio processes provide a means of constructing a sense of continuity; here narrative might be seen as ‘another powerful device by which the actual discontinuity between drops of experience is passed over’, and as ‘a verbal meta-continuity... angry words will be explained, justified, rationalized, excused, given cause and made understandable, smoothed over. It’s fictional. And it’s palliative’ (Massumi, 2011, p.66). The act of ‘storying’ also becomes central in drawing attention towards the dynamism of the research process itself, by giving shape to the ‘something/happening’ (Whatmore, 2006, p.600), and drawing attention to the ‘*implicate* order’ of a world continually in movement, in which understandings about the nature of things are made ‘only by attending to their relations, or in other words, by telling their stories’ (Ingold, 2011, p.160).

Anthropologist Tim Ingold emphasises the knowledge generating capacity of stories by arguing that we build our understanding of the world not by assembling classifications about our environment and then applying them in practice, establishing ‘a homology between structures in the mind and structures in the world’ (2011, p.159), but that we know about our environment *by way of* practice, ‘that is, through an ongoing engagement, in perception and action, with the constituents of [our] environment’ (ibid.). He goes on to claim that the telling of stories is an act of *relating* events of the past in a way that they are brought back to life in the present, ‘recursively picking up the strands of these past lives in the process of spinning out their own’ (p.161). One example of this might be found in the way narratives around place are used not just as a way of nostalgically reflecting on the past, but also as productive forces in constructing new ideas of belonging (Blunt, 2003; Bonnett, 2006; Bonnett and Alexander, 2013).

Over the last two decades, qualitative research methods have embraced ‘partial, plural, incomplete, and contingent understandings’ (Denzin, 2003, p. 8) often through biographic and autobiographic practices. These have emerged as approaches to research that attempt to challenge the authoritative displacement of the researcher/observer by reinstating her ‘at the scene of lived experience’ (Gannon, 2006, p.3). Although these are often gathered under the rubric of autoethnography, methods may include the use of fictive writings, conversations, performances, or visual presentations (Ellis and Bochner, 2000; Denzin, 2009, pp.205-206). As previously noted, precedence for these approaches to research can be traced to a wider disenchantment with classical empiricist methods in the latter decades of the twentieth century. Whilst the empirical voice was always manifested in the explanation and representation of the research object, in classical empiricism, these personal experiences are suppressed by an overarching requirement for neutrality and objective distance. For example, the historian James Clifford, writing on anthropological practice, contends that by treating cultures as ‘objects’ to be described or interpreted we take no account of the partiality of experience. We presume a whole picture in which universally identifiable gaps might be filled:

Cultures are not scientific “objects” (assuming such things exist, even in the natural sciences). Culture, and our views of “it,” are produced historically, and are actively contested... If “culture” is not an object to be described, neither is it a unified corpus of symbols and meanings that can be definitively interpreted. Culture is contested, temporal, and emergent. Representation and explanation—both by insiders and outsiders—is implicated in this emergence. (Clifford, 1986, pp.18-19)

Clifford locates this reflexive turn within the context of representational crisis, the destabilising of taken-for-granted assumptions that subject and object form the stable poles of an explanatory axis. By acknowledging the partiality of the author and implicating her in the co-construction of the research object, reflexive accounts, on the face of it, appear to offer a means of squaring away the ‘epistemological rift between subject and object’ (Pels,

2000, p.2), or as Alvesson and Sköldbberg put it:

There is no one-way street between the researcher and the object of study; rather, the two affect each other mutually and continually in the course of the research process. A positivistic conception of research, according to which the object is uninfluenced by the researcher and the researcher is unaffected by the object, is thus untenable. Both researcher and object are involved in common context, and are thus context-dependent. (2000, pp.39-40)

For practice-based, practice-as, or artistic research methodologies, reflexive attitudes are often seen as providing a way of picking apart the knotty problem of the artist/researcher as both subject and participant, ‘author’ and critic (cf. Stewart, 2003; Gray and Malins, 2004, p.57; Sullivan 2005, p.100-101; Haseman, 2006; Crouch, 2007; Barrett 2010a; Mäkelä et al., 2011; Slager 2011, p.338; Borgdorff, 2012, pp.39, 81). Commentators like Estelle Barrett (2010) see reflexivity as a means of establishing ‘emergent methodologies’ within arts research (p.6) in which relations between researcher and research object are continually readjusted. For Barrett, reflexivity critically unseats the notion of the artist as the autonomous originating subject of research material, independent from the research process—a figure described by sociologist Pierre Bourdieu as the ‘uncreated “creator”’ (Bourdieu, 2003, p.96). This is an ideology of the artist divorced from any of the usual social groups. As a methodological tool reflexivity acts recursively to *situate* the researcher not just in relation to the immediate field of artistic enquiry, but in the extended field of artistic production (p.99), or as Barrett puts it ‘involves not only a focus on the validation of data and outcomes, but also the positioning of oneself in relation to other fields in order to reveal the character and sources of one’s interests’ (Barrett, 2010a, p.6). Design historian Christopher Crouch (2007) describes reflexive practice along slightly different lines, that is, as providing a means of socially framing the results of individual creative practices. Reflexivity is advocated as a form of situated critical self-awareness that allows the creative practitioner to be both conscious of being within the act of creative practice and, at the same time, ‘enables the concept of the

creative act to be taken away from the supposedly autonomous individual and introduced into the social realm' (p.107), and thus 'takes the emphasis away from the narcissistic, without negating the importance of the self' (p.108). So, shifts in reflexive amplitude appear to oscillate between the experimental system itself in which 'knowledge creation... constantly undergoes change as new experiences "talk back" through the process and progress of making art' (Sullivan, 2005, p.100), and meta-analytic frames which reveal 'the plurality of new views, much in the same way a gallery curator does when reassembling a collection so as to present a different reading of artworks' (p.101).

So, reflexivity might be seen as a virtuous approach to creative research, one that offers a critical base for situating art-making experiences within a research domain whose truth claims are often seen as deeply subjective. At its root it can be seen as an attempt to lay bare the relationships between the knower and the known. And yet in the active and immediate experience of making work, attention to certain aesthetic impulses often overrode a rational sensibility to attain a temporary fix on the self-conscious artist manipulating an 'object-in-formation'. Those observations that did emerge in the form of (studio) annotations provide a log of technical and reflective notes and scribbles which point not at an establishing of viewpoints, but towards a series of arcing and overlapping streams of thought (see "Tracing and Assembling" on page 69). It is only later, at a writing desk, sifting through the contact sheets, annotations, images of similar artworks or artefacts, academic papers and textbooks, that I might have started to feel sufficiently removed from the experience of physically making, to step back in order to find a transitional point from which to establish a series of meta-analytic frames through which these apparently truculent art 'objects' might be explained. Yet even here I find myself caught up in the event of writing from which the materials collected and collated for the purposes of 'reveal[ing] the plurality of new views' (ibid, p.101), are assembled and disassembled in varying formulations. The materials of 'fieldwork', photographs of outcomes, GPS tracks, drawings and notebooks, etc., take new forms in the image 'archive' (Lorimer, 2010) and 'transcript' (Laurier, 2013).

The 'revealing' gaze of Sullivan's reflexive understanding of creative

practice implies distance from the event or act in order to invoke a meta-framing of the self *doing* research, one that is ‘one step up’ from the research process and in which it is ‘both feasible and important to talk about something and simultaneously talk (at least a little) about the talking itself’ (Pels, 2000, p.3). But in turning towards self-reflexive modes of analysis to achieve a greater depth of insight into creative processes, how do we maintain a place for those affective states or movement-experiences that occur in the experimental space of the studio yet don’t fit easily within the subjective positioning that certain types of methodological reflexivity imply? Decoding and interpreting the written and audio annotations made in the studio or on-site reminds me that these intensities are not easily redeemed, neither are they easily represented (cf. McCormack, 2003, p.492).

Ethnomethodologist Michael Lynch (2000) provides a vertiginous inventory of ‘reflexivities’ (pp.27-34), a number of which are methodological tools for *enhancing*, rather than undermining or unsettling, classical ideas of scientific objectivity. Lynch is critical of the view that being reflexive is simply accepted as providing ‘superior insight, perspicacities or awareness’ (p.26), as he sees it the claim that reflexivity (as a contemporary theoretical tool) casts an incisive critical eye over the outmoded and ‘unreflexive’ practices of our predecessors, often fails to recognise the degree to which these too often ‘had their “reflexive” modes and moments’ (p.34), that were often deeply associated with disciplinary or programmatic approaches to knowledge production:

Each of the reflexivities in my inventory—mechanical, substantive, methodological, meta-theoretical, interpretative and ethnomethodological—involves some sort of recursive turning back, but what does the turning, how it turns, and with what implications differs from category to category and even from one case to another within a given category. The extant versions of reflexivity go along with divisions among schools, programmes and perspectives in philosophy and the human sciences. (Lynch, 2000, p.34)

Lynch proposes a recognition of *difference* over quantity, arguing that what reflexivity is said to do depends on who does it and how it is done (p.36).

This is of particular importance when we examine some of the self-reflexive arguments advanced by Barrett and Crouch. Barrett, for example, suggests an idea of epistemic reflexivity based on Bourdieu in which ‘reflexivity demands that both the researcher and her/his methods be submitted to the same questions that are asked of the object of the enquiry’ (Barrett, 2010a, p.6), or as Bourdieu puts it ‘[h]ow and by what right can the researcher ask, about researchers of the past, questions that he does not put to himself (and vice versa)?’ (Bourdieu, 1993, p.49). To submit both the ‘object of enquiry’, and the objectifying gaze itself, demands a double objectification that depends on a further detached position ‘from which it is possible to objectify naive practice’ (Lynch, 2000, p.31). For Bourdieu this reflexivity is guided by attempts to establish the social determinations behind all epistemic structures, an attempt to see the social (collective) behind the personal, and in doing so is resolutely impersonal and anti-narcissistic. And yet paradoxically, by returning the emphasis to the individual analyst, and creating an object of the objectifying gaze there is, in theory, the danger that this form of reflexivity *becomes* both narcissistic and infinitely recursive (Pels, 2000, p.13; Maton, 2003, p.57). Sociologist Karl Maton describes the problem like this:

Imagine, for example, an author or knower A, who analyses an object of study B to produce knowledge C ... Following Bourdieu’s example, this budding reflexive author conducts an analysis of the relation between himself or herself and the object so as to produce a more reflexive account, that is, the objectifying relation A-B becomes an object of inquiry. Objectifying objectification in this way, however, raises the question of the relation of A to this new object of inquiry (A-B): In what ways does the objectifying relation between A and A- B shape the resultant knowledge claims, C? It becomes, in other words, a further possible focus for reflexive analysis. This recurs, for at each stage the product of reflexive analysis becomes a new object for objectification; it is always produced by a socially positioned actor in an objectifying relation, providing the potential for reflexive regression ... This form of reflexivity also quickly becomes narcissistic. Although concerned with “objectifying objectification,” the original object of inquiry tends to recede into the background as author A takes centre stage. (Maton, 2003, p.59)

Bourdieu himself was not unaware of the paradoxical possibilities, but he saw his own self-referential appearance in his work ‘not in a narcissistic sense, but as one representative of a category’ (Bourdieu cited in Pels, 2000, p.13). It is this categorical distinction between the individual and her determination in relation to a social collective that Crouch also sees as providing a critical self-awareness that preserves self-actualisation from narcissism (2007, p.108). Anthony Giddens provides the version of self-reflexivity that Crouch sees as offering the most appropriate route-map out of self-indulgent subjective narratives (p.106). He raises the question ‘[h]ow many individuals detach themselves from their cultural circumstances in order to dispassionately assess their actions?’ (p.107), and extends the idea of a performative attitude in order to create ‘the potential for the individual to assess the creative act from outside of the act, then adopting a reflexive viewpoint allows an understanding of the creative process from a subjective viewpoint, revealing the dynamic relationship between the context, construction and the articulation of the act.’ (p.108). In doing so he constructs the idea of a reflexive subjectivity from outside the activities or events of creation, and reaches towards an image of the reflexive practitioner as a more critically grounded researcher. But by abstracting the researcher from their actions, does he not also deny the possibility that being in the act of creative experience is the field in which subjectivities are also constructed? Perhaps there is a need to consider the possibility that the ‘event itself is a subjective self-creation’ (Massumi, 2011, p.8). For both Barrett and Crouch, the bigger project is centred on ensuring greater research presence in the visual arts within an Australian university culture, and in establishing research methods that might be more broadly accepted within this academic environment. The need to demonstrate the potential newness of artistic research methodologies, and simultaneously assert their rigour, is often manifested in introductions that stress the particularities of artistic practices whilst aligning them to the social sciences (cf. Borgdorff, 2012).

And yet over the last decade many writers in the social sciences are looking toward the active energy and affective intensity of art-making (and other practical engagements) as a way of reanimating arguments that have

become immured in attempts to find ever more descriptive representations of the research environment (Vannini, 2015). Many emphasise the experimental and unpredictable potential of a broad range of practices, from studio to laboratory, and see them as offering more playful, open-ended and mutable understandings of a world whose wholeness and solidity has been assumed, perhaps, for too long (cf. Knorr Cetina, 2001; Thrift, 2008; Massumi, 2011). So, for example, when science sociologist Karin Knorr Cetina asks ‘how can we theorize practice in a way that allows for the engrossment and excitement—the emotional basis—of research work? What characterization of practice might make the notion more dynamic and include within it the potential for change?’ (Knorr Cetina, 2001, p.184), I believe she is asking us to consider a theorisation of practice that resists fixed representation (p.194) in favour of incompleteness and a lack of ‘object-ivity’ (p.191). Rather than seeing the epistemic practices as simply learned behaviour that is we ‘deploy or enact in concrete situations’, Knorr Cetina argues for a less ontologically solid understanding ‘based upon a form of relationship... that by the nature of its dynamic transforms itself and the entities formed by the relationship’ (p.194; cf. Ingold, 2011, p.159). Cultural geographer Nigel Thrift assembles his argument not in the laboratory but directly in dance studio, proclaiming:

I want to pull the energy of the performing arts into the social sciences in order to make it easier to “crawl out to the edge of the cliff of the conceptual”... To see what will happen. To let the event sing you. To some this will appear a retrograde step: hasn’t the history of the social sciences been about attaining the kind of rigour that the performing arts supposedly lack? ... I believe that the performing arts can have as much rigour as any other experimental set-up, once it is understood that the laboratory, and all the models that have resulted from it, provide much too narrow a metaphor to be able to capture the richness of the worlds... Consider just the rehearsal: would anyone seriously say that it is not a rigorous entity? (Thrift, 2008, p.12)

Neither Knorr Cetina or Thrift entirely jettison reflexive consciousness in favour of a form of naïve practice, and indeed for Knorr Cetina it is precisely

a dissociative moment in routine practice that invokes the researcher's awareness of being 'in-relation' (Knorr Cetina, 2001, pp.188-189). And whilst Thrift sees the idea of 'privileging reflexive consciousness and its pretensions to invariance' (p.13) as providing no greater critical insight, neither does he want to drop the human subject entirely; rather he sees the human subject mixed with other 'subjects' in 'ill-defined constellations' and 'increasingly polymorphous combinations' (Thrift, 2008, p.118). However, Thrift rejects the possibility of maintaining unequivocal positionality by asserting that there is 'no longer such a thing as a relatively fixed and consistent person—a person with a recognisable identity—confronting a potentially predictable world but rather two turbulences enmeshed with each other' (Phillips cited in Thrift, 2008, p.13). And it is precisely this interest in the quasi-chaos of practice, 'compelled by their own demonstrations' that leaves room for 'values like messiness, and operators like the mistake, the stumble and the stutter' (p.18), which provide opportunities to consider the epistemic untidiness of artistic work in terms of a research engagement.

So, in this study I draw on ways of thinking that are somewhat sceptical of the 'metaphysical aura and (apparent) ideological potency' (Lynch, 2000, p.46), accorded to certain kinds of reflexive writing and making that claims to achieve greater methodological rigour by developing an idea of a meta-analytic subject that sits outside the event of practice. Instead I prefer to draw on theorisations that attempt to take account of the ontological insecurities and subject-forming possibilities of a dynamic research environment. In part this is an acknowledgement of the influence of a number of writers who stay faithful to the idea of a *radical empiricism*, which include Thrift (2008, p.5), Massumi (2011, p.29), and Kontturi (2012, p.32). Radical empiricism, which originates in the work of American pragmatist William James, emphasises continual change, or as Massumi describes: '[w]hat is radical about radical empiricism is that there are not on the one hand objective-transformations-leading-to-functional-ends and on the other, experiences-and-percepts corresponding to them in the subject... *both are in the transition*. Things and their experiences are together in the transition' (2011, p.30).

Although this is by no means a study in radical empiricism, what these

ideas lend to the practical-theoretical journey is a sense of immersion and an effort to acknowledge that the action of creation is also the action of subject and object creation that is continually remade in new meshworks of relation. These movements are less described than *echoed* in the research through passages that attempt to make sense of the chaotic, partial and contingent associations variously in-formation during the course of the study. At times these appear as elliptical dialogues rather than neat correlations between actions and effects. Acting as markers rather than discrete practical ‘projects’ in which research was ‘put to work’, three exhibitions form *instances* of practical intensity through and around which theoretical formulations both shape each future engagement, and are reshaped by them.

Three Movements

(1).

“Walking, Drawing & Map-Making” opens the first practical movement and introduces the first of three exhibitions, *Meeting Place: Contemporary Art and the Museum Collection* (2007), which was to be situated at the Russell-Cotes Museum and Gallery in Bournemouth. The museum, once the home of Victorian hoteliers and art collectors Merton and Annie Russell-Cotes, is now one of Bournemouth’s cultural attractions and houses, among other things, a sizeable collection of British Pre-Raphaelite paintings. The premise of the exhibition gestured towards a series of recent curatorial interventions in which contemporary artworks intervene or share space with historic cultural collections, often with the idea that one might shed a critical light on the other.

At the beginning of the 2007 I had been exploring the use of drawing along with audio and video recording, and geographical information systems (GIS) data from GPS tracking devices. I attempted to lose myself in the British countryside and record the experience of ‘becoming familiar’ with a place. I also tried to see how accurately I could narrate the passing landscape whilst blindfolded on a car journey along a familiar route. Through these I imagined I might find a way of describing a gradual transition that likened

place-making to becoming familiar with a specific environment. In these early experiments I was sceptical of idea that technology would provide a more truthful account of the event, yet still held to the idea that its use provided a certain facticity in what were a series of largely subject-centred artistic ventures. This was less a question of putting creative practice ‘in the “service” of geography’ (Hawkins, 2014, p.25), than an effort to establish some form of neutral, systematic and experimental process that might legitimise strategies for creating visual arts works within an idea of *doing* research. Underlying this was a certain nervousness about the role of practice *as* research, a nervousness that is not entirely unfounded given the debates that surrounded the relationship between fine art and academic research, (see also Borgdorff, 2012.)

When an opportunity arose to contribute to a group project around a museum in Bournemouth I took it, as it appeared to offer the possibility of turning these early wanderings from the landscape to a different kind of environment—the interior of a public museum. Here, perhaps, I might get to ‘know’ a place in a different way, one which could be navigated as a curated environment with a deeply layered history, but one that might also be mapped subjectively. Certainly there are no shortages of references to the home, to travel and to a colonial exoticism. This is filtered through the composition and display of objects, reconstructed interior spaces, positioning of explanatory texts, and by the addition of a gift shop and café. This glorious decorative time capsule feels isolated from the outside world. Perhaps this is why I approached the Russell-Cotes as if it were an island rather than a public space.

The initial works described the edges and outlines as I was walking the boundaries of the museum. Made from observation in continuous lines they were direct drawings that described the movement of following the edge of something, taking in the smallest turns. Moving inside the museum these continued to follow the same journey, this time around tables, skirtings, decorative frames or displayed artefacts. I had in mind that it was a way of

Overleaf:

Fig. 2.2: Preliminary tracings for
Meeting Place, (detail), 2007.

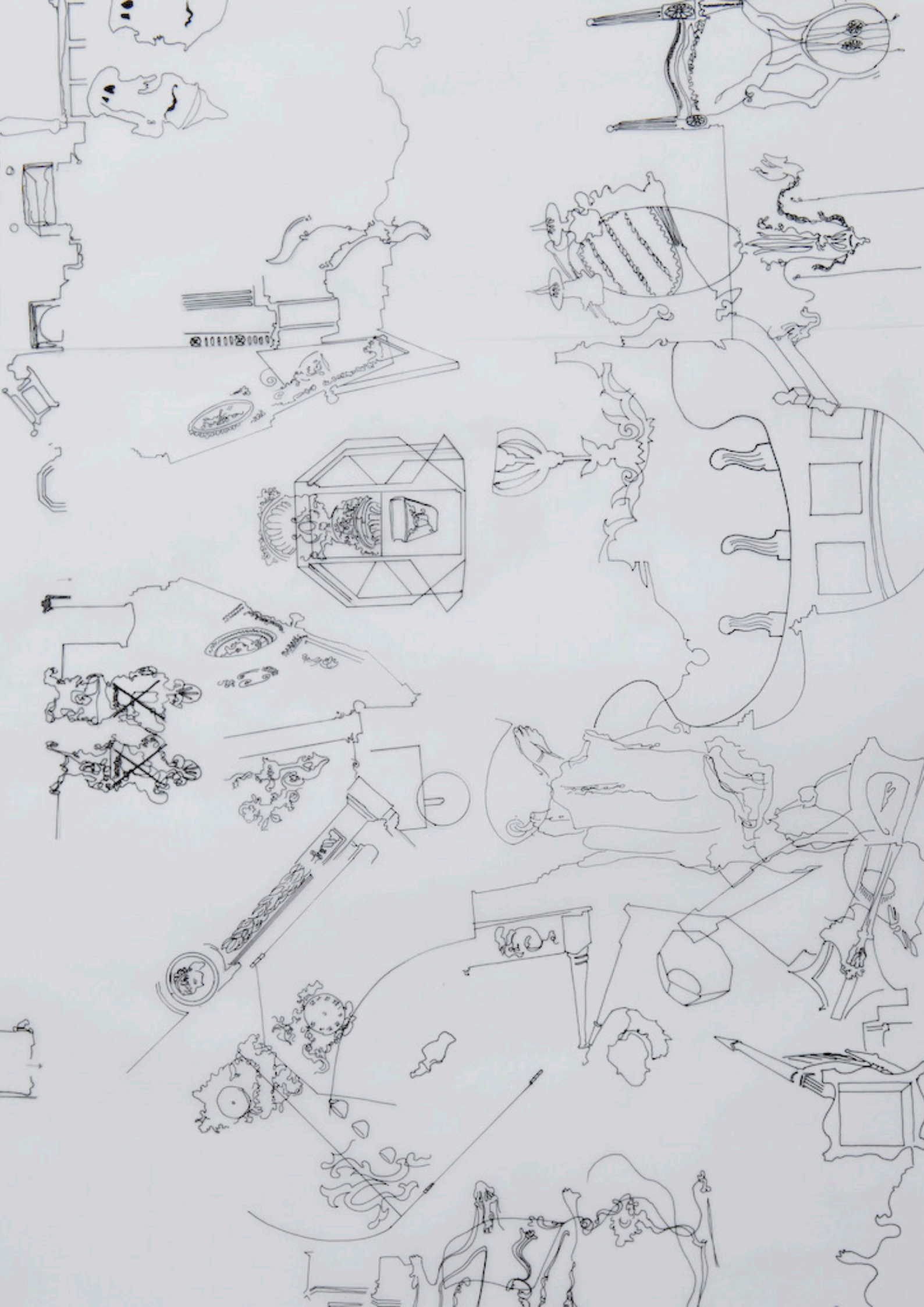

generating some kind of ‘visual data’, but it became a means of describing the dynamics of my own movements, across the street, the room or the page, that seemed to enmesh the acts of looking and moving.

Later these drawings would become part of more elaborate assemblages that attempted to harness together my own journeys with photographs of artefacts and images of social struggle that were contemporaneous with the dates and places of Annie and Merton Russell Cotes global travels, the Victorian owners who collected the assembled artefacts and who bequeathed the museum to the city in 1907. From these were constructed two images made up of tracings that would form various architectural and artefactual elements into decorative flourishes or vignettes. These were intended as attempts to reassemble of the existing order of presentation, one which temporarily bound artefacts, display cases, annotations and signage to an order of coloured rooms, paths and vistas throughout the interior of the public museum. But it was also an approach to creating work that fell into line with overarching curatorial ambitions of our contemporary intercession, that is to ‘intervene’ by way of inserting our own work into the logic of the museum display.

Much later, reflecting on the show and on my own responses, the curatorial predisposition towards institutional critique would, itself, raise new spatial questions. These were less easy to visualise than the marking out of architectural extents, but they would become pivotal in directing attention towards the activity of creating work rather than an interpretation of the outcome. This move was, in part, an attempt to move the focus of research beyond an idea that by reframing this historic collection in relation to contemporary cultural concerns I might reveal the hidden power geometries underlying the display (cf. Kwon, 2004, p.47).

(2.)

Originally sketched out with the title *Island*, the exhibition *Borderlands* took place a year later in 2008. The second movement “Islands” focuses on the work produced for this show, which initially set out to bring together parallel ‘reflections’ on the idea of borders and bordering from two writers and two

visual artists. They would consider not only geographic ideas, but also the bordering between the visual work and written text, all of which aimed at the idea of a discretely bounded entity, and a negotiation of the boundaries that appear to describe it.

The work produced for this show was grounded on a return to the studio, or at least that temporary part of the home I appropriated for the purpose of creative production. In claiming a small area of the house as a studio space the works I began to produce became contingent on the environment in which they were being created. The two by four metre space, one half of a shared office-slash-boxroom afforded a certain scale of art-productive activity, and whilst there was nothing preventing works from being created independently from the space, there was also a sense that the space in which works were created had some impact on the kind of works produced. As a self-reflexive reference to the locus of artistic production it would become one that progressed beyond the idea of the studio as simply ‘a symbolic place of production’ that might be contrasted with the street or site (cf. Wallace, 2012, pp.170-171), towards one that was constantly under (re)construction. Attending to what these arrangements of objects, technologies and human agents *did*, rather than what they represented, developed as a semblance of these activities *as* an entity also began to form.

(3.)

Four years later, in 2012, the exhibition, *Drawing Lines in the Sand*, opened on Cockatoo Island in Sydney Harbour. The third movement, “Home and Abroad”, follows the creation and distribution of work for a show that was by far the longest in development and most ambitious in production. The image-objects that finally made it to Australia emerged from similar rearrangements of household space and matter as the preceding works for *Borderlands*. But if these beginnings sprung from assemblages of domestic detritus they quickly departed from the near-habitual behaviours that had begun to form a regulated method for producing certain kinds of island-images.

Whereas *Borderlands* turned in on a space of creative activity, in the process becoming increasingly self-referential, *Drawing Lines in the Sand*

pointed towards a series of geographical locations that were not only beyond the walls of the home studio, but often my first-hand experience. One of these locations was Cockatoo Island in Sydney harbour. Gravitating towards the only experiences I had of Australia, the first images echoed those representations of landscapes often found on souvenir tea towels or printed on ceramic ornaments. I associated some of these with objects that returned with my grandmother on the trips she made to see our aunt, who emigrated to Australia in the mid-nineteen sixties, and others with ideas of British landscapes that I found in local charity shops. As the images progressed I found myself collecting material, both as a reference and for its potential use, in the gift and charity shops on the local high street. Gathering artefacts such as ceramic tankards or printed with picturesque images of rural scenes was a means of alluding to the exchange of landscape narratives that accompanied the gifting of souvenir objects. Many of the objects that accumulated in charity shop windows already showed signs of travel fatigue. From their original source of consumption; gifted and displayed; exchanged or bartered for; reused and recycled through the secondhand outlets in the town centre.

Working with these objects created new dynamics and new problems. These might be summed up, as the artist Richard Wentworth does (Wentworth, 1988, 10:38-11:42), in terms of mutual co-operation. But whilst the collected objects can be seen as more or less useful in one or other personal artistic scheme, their co-operation was not a one-way thing—objects impressed material and iconic qualities that shaped the direction of work in the studio. And these charity-shop bibelots were not the only objects that were being assembled. In this phase of the research attention also turned to the things being formed as artworks and to their mobilisation. Digital image files, CAD drawings, laser cut and heat-formed plastics, CNC-routed fibreboard were ordered, shipped, emailed. Versions, mock-ups, tests. Underlying the careful construction of each image was a meshwork of exchanges that brought new arrangements of material through the rooms I appropriated as studio spaces or workshops.

The final works made their way to and back from Australia without me, and whilst I started out with the semblance of half-remembered souvenir



Fig. 2.3: Pencil sketch for *Nadir*, 2008.

gifts that described a place I have never been to, the resulting artworks were repeatedly reconstituted into a various alternative narratives of place and displacement. In Australia the image-objects I produced were themselves reproduced in flyers, press releases, magazine articles, websites, on-site talks and catalogue pages, often alongside descriptions, explanations and other discursive tracts. Together these images, texts and objects became part of a curatorial response to Cockatoo Island's institutional heritage, to the legacies of colonialism, to ideas of interiority and exteriority in an Australian context, and to 'the Western colonialist tropism of island territories as condensed sites of acquisition, containment and control.' (McMahon cited in Taylor and Peloton, 2012, n.p.). Each re-presentation involves making the work anew, in which constellations of material objects, biographical events, contextual links form a continuum of successive 'takings', a term Brian Massumi uses to describe the relaying between events through which experience forms an object of itself (2011, p.8).

So, in the last of these exhibitions the focus turns towards travelling, not

simply of the artworks but, as geographer Tim Cresswell puts it, the '*ideas* that travel alongside humans and things.' (Cresswell, 2014, p.713). This is not to turn away from material agency of the work in favour of an interpretation of what they mean or show, rather it is to follow a co-presence of ideas, humans and things in *motion*.

As I have previously noted, these exhibitions were not conceived or narrated as ends in themselves, that is, they are not discrete case-studies or separate research projects with definitive outcomes, but points in the progression of practical engagements around which rumination and discussion take place. Some feel like turning points, although these shifts in direction may have felt marginal at the time, a question of degrees rather than a seismic lurch. Once travelled, however, some of these small rifts begin to look like chasms. It is often between these projects, as a culmination and separation from one period of intensity begins to anticipate the next, that these events take form as identifiable stages, for that reason I have also included a body of drawing under the heading 'A Swiss Sojourn' that does not fit into any single exhibition event but opens out a reflection on the forming and self-forming movements of the research.

If one recurrent motif that weaves between these pulses of creative intensity might be brought to mind here it is that of the island. It is an image that immediately seems to conjure separation and origination, or as Gilles Deleuze describes it 'extends the double movement' (Deleuze, 2004, p.10) not simply of being formed in its singularity, but also of forming in the imagination a separation from the world. Geographer John R. Gillis also remarks on the hold that islands have had on the Western imagination, observing that the 'image of the island was one of humanity's initial means of thinking about its place in the world and in the cosmos' (2007, p.275). But Gillis also goes on to reflect on both the pervasiveness and the persuasiveness of this image in helping to form an idea of the world in terms of neatly bounded entities and insulated things. Citing the American poet and travel writer Gretel Ehrlich he draws parallels between islands and knowledge formation: 'To separate our thoughts into islands is a peculiar way we have of knowing

something' (Ehrlich cited in Gillis, p.276). Instead, he argues, we should pay more attention to the gap between these bounded entities, in this case the movements between islands and sea. Numerous similar arguments, advanced by geographers such as Kenneth Olwig, (2007), Godfrey Baldacchino (2007), Elaine Stratford (2003; see also Stratford et al, 2011) and Gloria Pungetti (2012), urge us to 'unsettle certain tropes: singularity, isolation, dependency and peripherality', in order to understand 'how this "world of islands" might be experienced in terms of networks, assemblages, filaments, connective tissue, mobilities and multiplicities, (Stratford et al, 2011, p.114). If these projects share this island-motif it is perhaps with the acknowledgement that thinking *of* islands, and perhaps *with* islands, is also bound up in a transition from singularity to multiplicity. It is a turn towards *in-between-ness*.

P12

BERNINA



3. WALKING, DRAWING & MAP-MAKING

Walking, Drawing & Map-Making

Central to this chapter is the creation of work for the exhibition *Meeting Place: Contemporary Art and the Museum Collection*, a group exhibition that the curators intended to be both a response to, and an intervention in the housing of a historic collection of artefacts at the Russell-Cotes Museum and Gallery. This show, however, also occupies the middle-ground between two other bodies of map-related works, narrated here in the sections “Driving Blind & LOST in Dorset”, and “A Swiss Sojourn”. These ambulatory drawing excursions introduce some of the difficulties I encountered in *Meeting Place* and extend some of the more performative aspects of drawing following the show, in order to forefront the flow of the drawing experience. Many of these early ideas were guided by the conviction that I was ‘mapping’ in one way or another, documented in the form of annotations, marks, recordings and images of the surrounding landscape, that might be returned to the studio for analysis. In the course of this gathering, however I became increasingly aware of my own physical movements, and in the orientations and contortions of my body as I tried to draw whilst walking through these environments.

In the first months of study I devoted a good deal of my time to both the history and activities of artists that have used, and are still using, mapping practices as a central aspect of their work. These influences and references were gathered as much from the post-studio evictions of the late 1960’s as they were from the recent growth in various forms of artistic cartography (Bourriaud, 2003; Watson, 2009) that are often centred on critical engagements within contemporary cityspace. A number of these, for example Christian Nold’s series of emotion maps (2005; cf. Nold 2009) or Pierre Joseph’s plan of the Paris Métro (2000) attempt to reinsert a human subjectivity into their mappings as an apparent challenge to the neutrality of cartographic science. However, it is difficult to say whether the artworks I began making in 2007 preceded or progressed from the idea of cognitive or emotional map-making,

since there had been a series of ongoing sketchbooks that ‘mapped’, in a loose sense, motorway journeys that I had taken through Europe in the previous two to three years—maps that focussed on repetitious images of road markers and motorway architecture, but I also came to those early ‘projects’ with some understanding of the role that mapping had in various art histories. As an approach or response that attempted to capture the ‘onflow’ of a passing environment with as much immediacy as I could express through the act of drawing (fig 3.1), there seemed to be the beginnings of a potential strategy that might be employed to negotiate ideas of space and place. It also seemed appropriate to adapt an existing way of working to attend to this specific question, but to find a way of articulating it so that it might be considered within the framework of ‘research’. I looked for a series of contextual pivots from within the visual arts that were directed at similar problems. These came from mid to late twentieth century European and American works whose central concerns had been the representation and presentation of space, and whose principal interests might be defined under the banner of psychogeography, a term coined by the writer and artist Guy Debord in the late 1950’s. Debord himself describes psychogeography as the ‘study of the precise laws and specific effects of the geographic environment, consciously organized or not, on the emotions and behavior of individuals’ (Debord cited in Gregory et al., 2009, p.597). Its use today, however, is often extended to a broad range of literary, artistic and political strategies for dealing with the environment (Coverley, 2006, p.9).

I already had some knowledge of twentieth century artists and cultural activists, for example the Situationist International, who had set out to present an experiential understanding of the city as a retort to the bureaucratic authority of urban planners and developers. I recognised that this had developed in late-twentieth century post-urban landscape, into a search for new spatial understandings that acknowledged a shift towards the periphery and away from the progressively regionalised centres of the modernist metropolis. I also saw the debt my own mapping pieces owed to British psychogeographers such as Richard Long and Hamish Fulton, whose shift into rural spaces also provided an alternative means of engaging with

Overleaf: Fig. 3.1: Sketchbook drawings made on motorway journeys, 2002

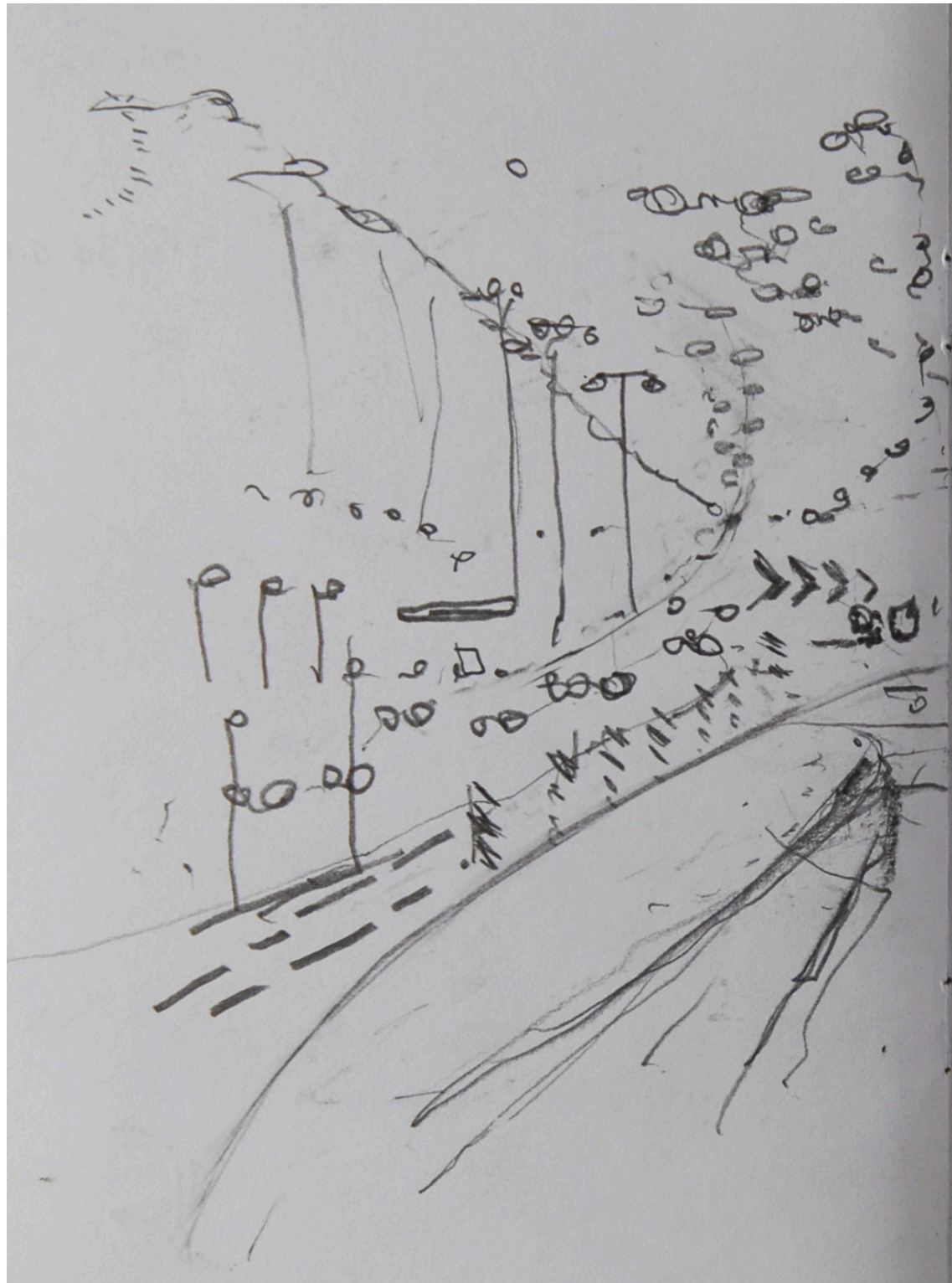

omroep.

1952

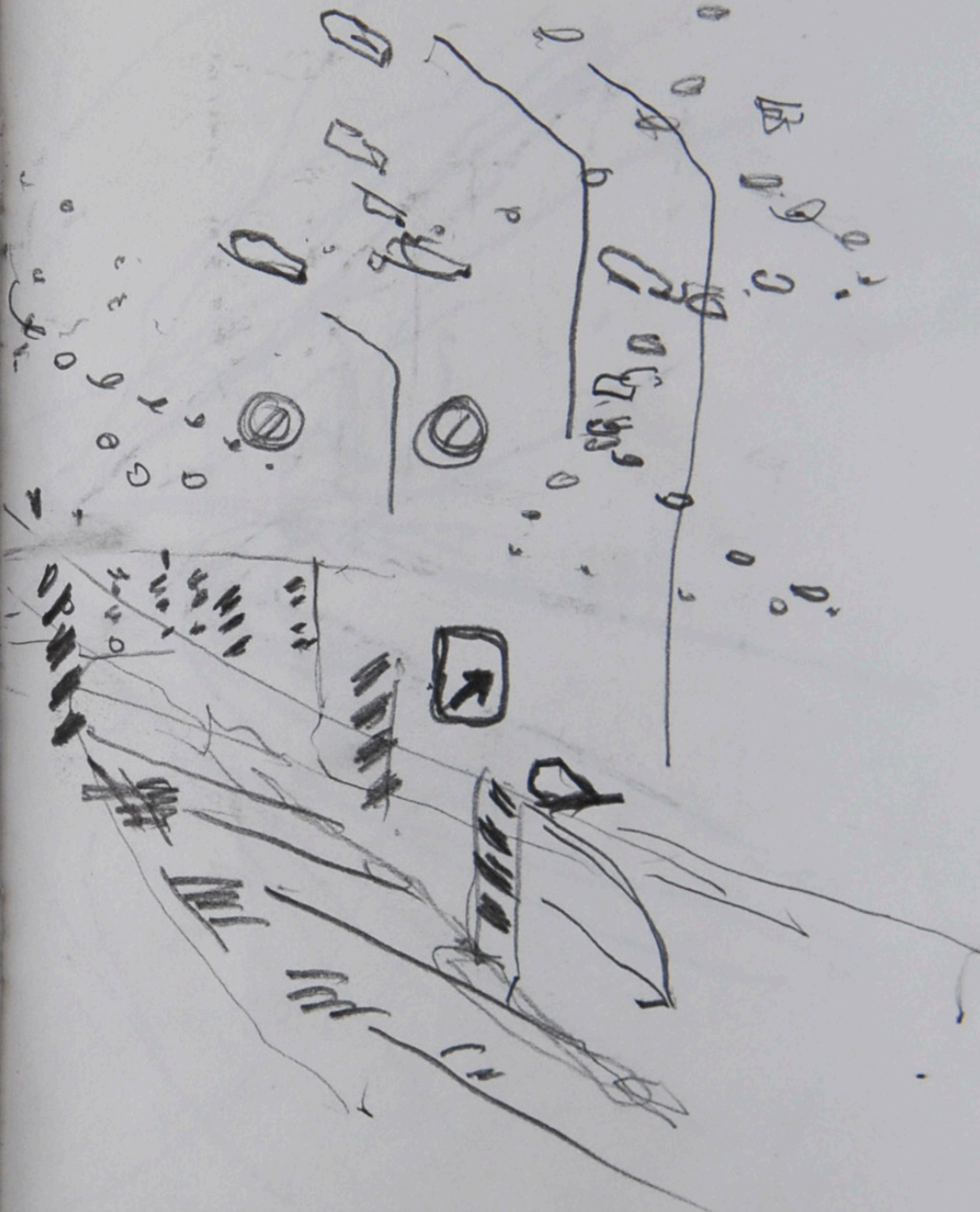



Fig. 3.2: Stills from *Driving Blind*, 2007.
Digital Video.

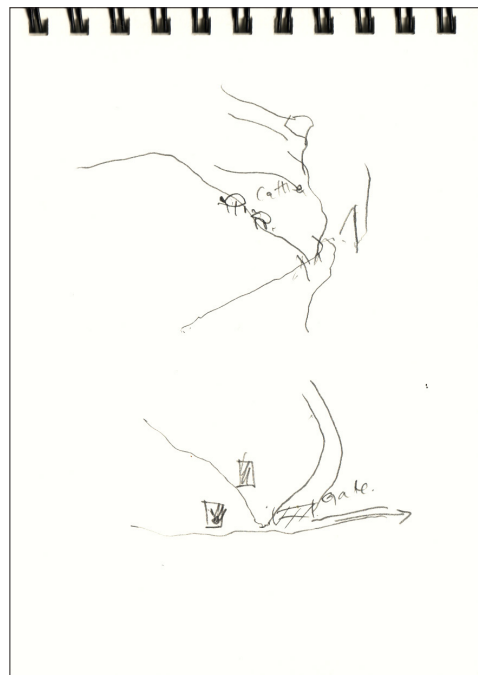
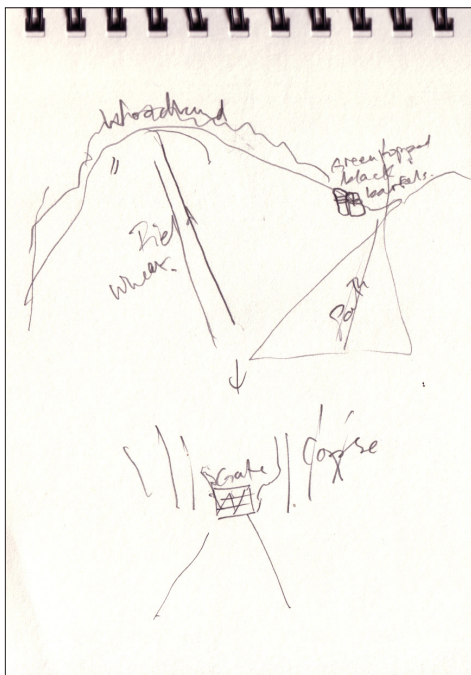
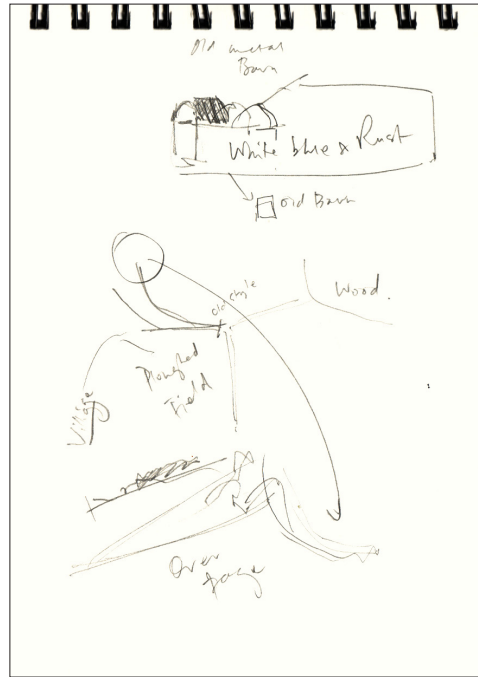
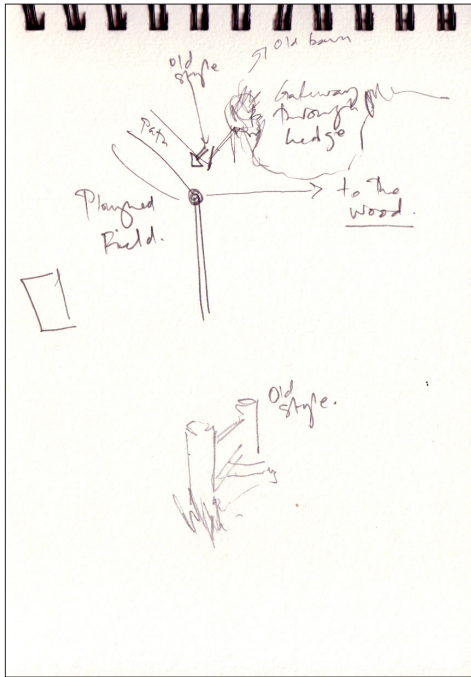

Fig. 3.3: From the sketchbook *LOST in Dorset*, 2007.

the land and landscape. These seemed important considerations as the early practical work was located miles from the nearest urban metropolis, around the open agricultural spaces and villages of North Dorset.

As I looked towards more recent works I began to frame these early experiments in relation to the interests of recent contemporary artists such as Franz Ackermann, Nathan Carter and Christian Nold, and alongside theoretical developments within the field that has become known as ‘critical cartography’ (Wood, 1992; Crampton, 2002; cf. Crampton and Krygier, 2006). Between these disciplinary perspectives a narrative began to develop in which assumptions about the oppositional role played by artists in strategically un-mapping or re-mapping underlying power geometries and signifying systems of maps, gave way to a more process-orientated understanding that focussed on maps *as* practices, largely through engagements with the work of cartographers Rob Kitchin and Martin Dodge (2007). Turning to the idea of maps as incomplete things—‘beckoned into being through practices’ (p.343), as opposed to, say, codified representations of power—only destabilised my own understanding of the map-work I was producing at the time, but also raised questions about the way I thought of the objects I produced more broadly.

Driving Blind & LOST in Dorset

The first works I produced as part of this study, I considered as tactical endeavours — played out in the form of discrete projects. *Driving Blind* (2007), (fig. 3.2), formed the first experimental piece, in which I documented a blindfolded journey taken as a car passenger along a familiar route from my house to a nearby light industrial park. In this excursion I hoped to isolate a sensory familiarity with the landscape that didn’t rely on what I saw. It was founded on a sense that I might recover the experience of previous journeys in the turns and bumps, sounds and smells, of a route I had taken many times before. Perhaps the belief that somewhere hidden behind the taken-for-granted experiences of travelling this route I had constructed a sensory map that might be revealed by the deprivation of vision. And I felt that in

revealing and separating this world I might find some means of representing it.

After the event I chose to represent it in a form that seemed to suggest something ‘factual’—a chart that measured the time between when I described a place I thought we were passing and the point at which we passed it, recorded on a video camera on the dashboard. In a parallel experimental work, *LOST in Dorset*, (2007), (fig. 3.3) undertaken shortly afterwards, I felt I should attempt to get lost in an unfamiliar part of the local countryside, (on reflection the belief that I might lose a sense of familiarity simply by driving five or so miles from home was somewhat optimistic). I was driven blindfolded to a place in the middle of the Dorset countryside that I had not previously been to, in order to map my way through the experience. Again, looking back I sense an underlying logic that somehow I would discover something about the way I orientated myself and, in the process, constructed a loose mental map. I wanted to investigate how I went about navigating space, and describe the experiences I felt I was having, by connecting the performances of travelling or moving to the collection of empirical data through Geographical Information Systems (GIS) such as GPS recorders. And so I took with me a number of tools to document the experience, an audio recorder to record my spoken thoughts, a pencil and notepad to record how I connected visual landmarks, and a GPS device to record my wanderings.

Both these early works are, in some ways, prescient of later attempts to consider the mobile and contingent creative spaces in which work is produced. But these early works were founded on the belief in space and place as distinct objects of inquiry, hidden entities from which certain qualities might be revealed through well-designed art responses. I had framed these ideas against a broad interpretation of place and space drawn from the work of phenomenological geographers such as Yi-Fu Tuan. The interest in a sensory understanding of ‘place’ that was derived from an affective bond with the environment (Tuan, 1990, p.4) provided the opportunity to explore a perceptual approach to map-making that might reflect on a differentiation between the immediacy of various experiences of a place. And yet it was also a way of defining ‘place’ in terms of familiarity; place as space which is

meaningful or in which an emotional relationship has been invested (Tuan, 2001, pp.6; see also Cresswell, 2004). Conceiving a relationship between the two in this way suggested an approach that would navigate a relationship between the familiar, the not-yet-familiar and the entirely unfamiliar as if there were a borderline across which the work would navigate these two terms as if in *tension*. Whilst perhaps not offering a well-considered argument for place as meaningful space, this was also to be considered a practical and experimental proposition, an involvement in the process of making ‘work’. *Driving Blind* and *LOST in Dorset* fixed the perception of environment to a pivotal relationship between sense and experience. Influenced by Yi-Fu Tuan’s *Topophilia* (1990) I thought I would describe this sense experience in the process of undergoing it. For the first of these it seemed appropriate that I might remove the visual from the experiment, in an attempt to draw on other bodily senses. For the second I attempted to describe both verbally and visually:

The person who just ‘sees’ is an onlooker, a sightseer, someone not otherwise involved with the scene. The world perceived through the eyes is more abstract than that known to us through the senses... A human being perceives the world through all senses simultaneously. The information potentially available to him is immense. (Tuan, p.10).

There were also numerous recent creative projects that I felt might provide justification for these approaches in terms of both research and artistic production. Some of these were cartographically-based art projects that presented the possibility of new discourses on place by using collaborative technologies and locative media, or global positioning systems (GPS). Group works such as *Urban Tapestries* (2002-2004) and *Social Tapestries* (2004-2008) by Proboscis, centred on ‘a fundamental human desire to “map” and “mark” territory as part of belonging and of feeling a sense of ownership of our environment’ and enable ‘a community’s collective memory to grow organically, allowing ordinary citizens to embed social knowledge in the new wireless landscape of the city... [and] to enable people as their own authors and agents, not merely as consumers of content provided to them by telecoms

and media corporations' (Proboscis, 2005), statements highly reminiscent of those made by Guy Debord and the Situationist International. There were also individual projects such as Layla Curtis' *Polar Wandering*, (2006) which also presented 'specific points and incidents' (Curtis, 2013) alongside a GPS tracing, suggesting both a journey through an abstracted space and the recording of an experience of a specific site. Like a number of other artists who make use of the relative accessibility of geographical information systems (GIS) such as GPS reinforced a conception of separation between the emptied cartography of global space, against which one's movements become plotted paths, and the yearned-for sense of belonging or recognition identified in terms of the experience of a specific place. In both cases the idea that one could easily separate information provided in the form of quantitative geographic 'data' from those topographic experiences that might be more qualitatively defined, seemed, at the time, quite reasonable.

Yet, as evidence of a sensorial exchange between myself and the landscape, the written and variously recorded 'data' proved difficult to interpret both as research material and artistic resource material, perhaps largely because I also seemed to be grasping at an *idea* of conducting an empirical research project, whilst remaining somewhat coy about what my intentions were in terms of an arts practice. As both experimental records of an experience *and* as material that would be constituted as, or in, visual artworks it immediately began to raise questions around the purpose of both drawing and recording in establishing a dialogue between 'familiar' and 'unfamiliar' geographies, how these works navigated between artful (gestural, abstract) and direct (documentary, descriptive) presentations. The implied formality of a direct 'documentation' of a spatial entanglement, whilst professing a certain objectivity, also generated new philosophical difficulties in the treatment of a spatial experience as something that is 'out there' to be 'mapped', rather than a complex recognition of the role of the self that is *doing* the mapping.

Meeting Place: Contemporary Art and the Museum Collection.

September 2007.

Mainlanders often harbor a subconscious obsession to frame and map an island cognitively, to “take it all in,” to go up to its highest point or walk around its shore, thus capturing its finite geography... In so doing, one feels that one knows, and therefore controls, the island more thoroughly and intimately. (Baldacchino, 2007, p.165.)

In 2006, whilst developing early projects such as *LOST in Dorset*, I was presented with the opportunity to produce work for a group show. The exhibition was organised as a group response to the collection at the Russell-Cotes Art Gallery and Museum in 2007. This was a site specific project, a response to a museum and gallery that housed a noted collection of Victorian art and artefacts. The premise of the show was to provide a contemporary response to the site itself, and the collection of artefacts and paintings amassed by the Russell-Cotes Family between the latter half of the 19th and early 20th Centuries. The show acknowledged the legacy of a number of previous projects that had brought together museum collections and contemporary art: *Time Machine* in the Egyptian Rooms of the British Museum (1994); *Retrace Your Steps: Remember Tomorrow* at the Soane Museum and *Give and Take* at the Victoria and Albert Museum and the Serpentine Gallery both in 2001. In the same vein as these exhibitions, and probably many similar, the curatorial emphasis was to provide the audience with a visual dialogue in which the museum collection was reflected or refracted through the work of contemporary artists. The contemporary work would sit alongside, cover, or intervene in the displays of artefacts that made up this Victorian collection.

As a site the Russell-Cotes Museum appeared to offer a point at which a number of earlier interests might be converged into one project, and directed towards disclosing a complex site. And indeed the shifting history, from an architecturally commissioned residence to civic museum and gallery, was evident the architectural fabric. The original residence, East Cliff Hall, belonged to the prosperous Victorian hoteliers Merton and Annie Russell-

Cotes, who had commissioned the architect John Frederick Fogerty to design the property to house their growing collection of art and antiquities in 1898 (Waterfield, 1999, p.863). The building has been described as ‘an exuberant Italian villa/French chateau/Scottish baronial style’ architecture (Kathryn Moore Heleniak, 1999), but whilst the exterior displays a playful facade, the interior was clearly meant for serious entertaining, ‘sumptuous dignified living, and... the display of works of art’ (Waterfield, *op. cit.*). Merton Russell-Cotes was considered a serious collector and traveller, whose travels to Australasia, America, India, the Near East, Egypt, the Pacific Islands and Japan had netted him a sizeable collection of ‘the rarest treasures’ (Furniss, 1892, p.171) from various countries around the world. Besides these ‘souvenirs’, Merton and Annie Russell-Cotes also visited the houses and studios of some of the most well known artists of their generation, including those of Alma-Tadema, Edwin Long, and Lord Leighton. They often bought works directly from artists or from the autumn exhibitions at the Walker Art Gallery, Liverpool and the summer shows at the Royal Academy (Kathryn Moore Heleniak, 1999). In doing so they amassed a vast collection of Victorian and Pre-Raphaelite painting, including notable works by leading Pre-Raphaelite and Aestheticist painters such as Albert Joseph Moore.

The interior of East Cliff Hall was visually eclectic with elaborate decorative plasterwork, ornate moldings and architectural features, stained glass and stencilling. This was matched in the contents of these rooms and, to some extent, the way in which architecture and ornaments (figs. 3.4.-3.7) were brought together in the curation. Travelling through the museum was something of an assault on vision. So much so, I was discovered, that the staff offices at the centre of the building were deliberately devoid of any decoration and colour so that they could escape the visual tumult of the floors above. This, however, did not appear to be just a recent curatorial conceit:

From the early days this hall was filled with a bizarre assortment of objects. These included a fine collection of Maori axes, cloaks, and armor; the natural history specimens that particularly appealed to Annie Russell-Cotes; sixteenth-century armor; Chinese and English porcelain and assorted earthenwares; Norwegian wood carvings;



Fig. 3.4: Cabinets in the *Mikado Room* at the Russell-Cotes Museum.



Fig. 3.5: Ornamental chairs in the Russell-Cotes Museum.



Fig. 3.6: Furniture molding: Russell-Cotes Museum.



Fig. 3.7: Architectural decoration: Russell-Cotes Museum.

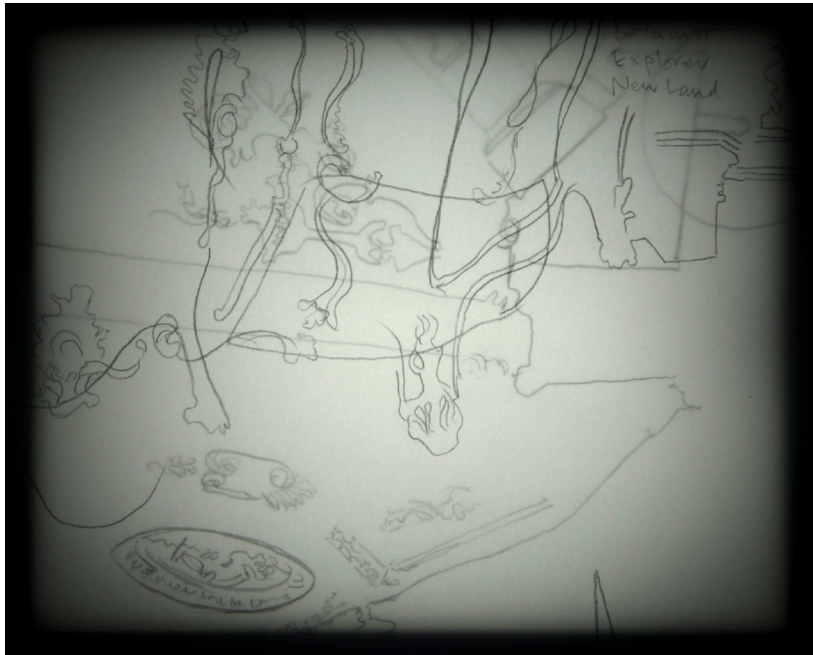

This page and over:
Fig. 3.8, (i-iv): Preliminary drawings for *Meeting Place*, 2007.
Graphite on drafting film.

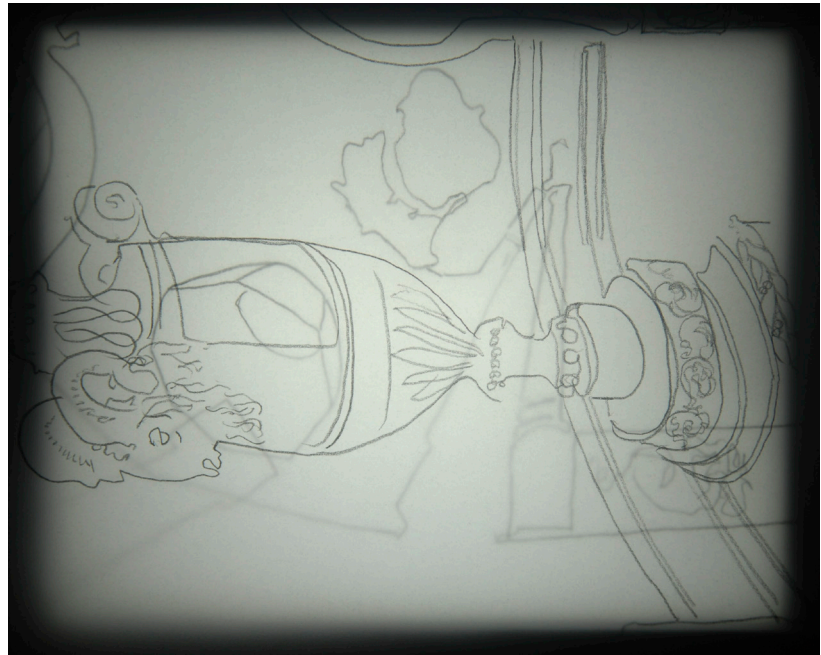
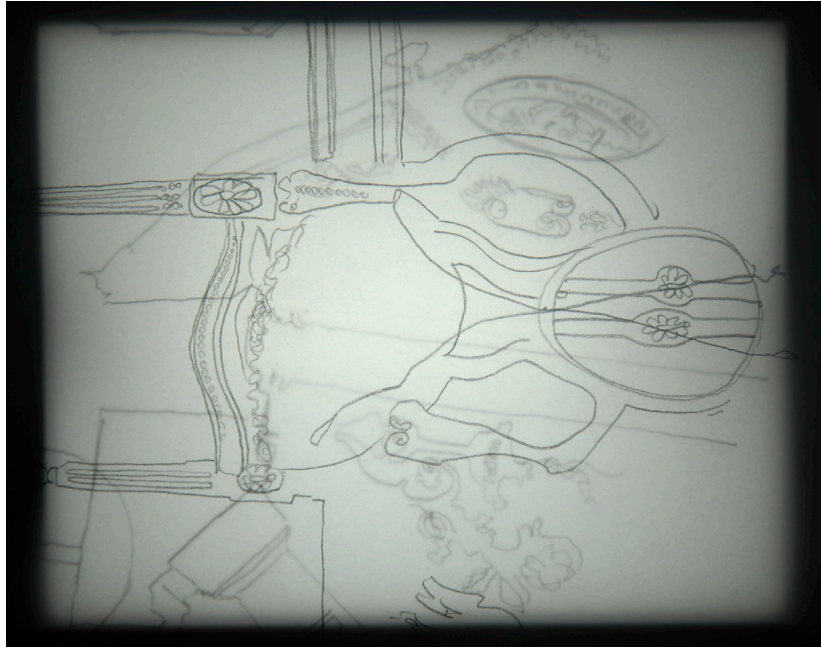

laundry mangles; illuminated testimonials to the Russell-Coteses in silver; and marble busts of Lord Nelson, Oliver-Cromwell, Florence Nightingale, and other worthies, including, of course, Sir Merton and Lady Russell-Cotes. Any remaining wall space was filled with pictures. (Waterfield, 1999, p.863)

Whilst the house was officially gifted to Bournemouth in 1908, the family continued to reside there until 1922, when Sir Merton Russell-Cotes died, one year after his wife Annie. Various restorations and redevelopments have provided a modern cafeteria and shop and an extension to the existing gallery that largely houses exhibitions of contemporary craft. Most of the original architecture inside the hall itself has been restored and a number of the rooms laid out either to recreate an 'original' domestic setting or as a more formal display of museum objects.

Although I considered *Driving Blind* and *LOST in Dorset* to be the principle strategies for developing practice in terms of a particular view of research, one in which a series of constructed projects might be aligned to identifiable goals, this exhibition seemed like an opportunity to take a detour from the what I saw as gathering 'fieldwork' data. Initially, I thought this would be an extension of personal practice, albeit one that was already beginning to adopt some of the approaches to making drawings that were extended in works like *LOST in Dorset*. It seemed as if this was also an point at which to consider how this site-orientated map-work might be turned towards a site that was also a museum and gallery. I made a number of preliminary site visits in order to get a sense of how I might use this commission to extend those experimental pieces I had made in North Dorset. So, again I began by taking a GPS tracking device, a notebook and drawing materials, intent on re-enacting a similar strategy to that in the previous walk. It became evident, however, did not provide the kind of information I expected. The slowness of my wanderings, the built up environment, these provided a series of traces in which the tracking of my position was continually being realigned—drifting in series of criss-crossed lines. Reluctantly I put the device away and went to meet a colleague, Tom Hall, in order to discuss the site itself and simply walk around it. This arranged meeting became the subject of a short text I

prepared for the catalogue some time later, one that is still telling about the way I considered the experience.

This catalogue text begins with a quote taken from the book *Desert Islands and Robinson Crusoe* (1988) by the poet and author Walter de la Mare. De la Mare is, in fact, quoting another author, the journalist and travel writer H. M. Tomlinson, who is describing a journey to Lundy Island. This is particularly apt because whilst the previous experiments were planned, with some sense of an outcome, here I became immediately confounded by the sheer scale and ornamentation of the museum's overbearing architecture, and rather than seeing a direction, a path or a route, I saw a mass; an island. On site I immediately set about inscribing the somewhat topological distinction between the property and the road beyond by walking its periphery and drawing a line across the A4 page of a sketchbook that in some way described or interpreted this 'edge'. I was not, as far as I recall, thinking about this act as 'research' anymore. I was not, in fact, thinking about much at all, save for a half-remembered quote about the impossibility of creating a map of an island.

It was a quote that I had found in the catalogue for a Rodney Graham's exhibition, in which he presented his hypnotic, Crusoe-esque film *Vexation Island* (1997). The writer and artist Robert Lindsley provides a description of the impossibility of measuring the shoreline, since in performing this operation, one is forced to consider how the apparent precision of the cartographers line describes a transient and indefinitely twisted border.

A map of the island will necessarily call for a simplified contour drawing of the coast. If, in effort to make a more accurate map, we look more closely at the shore, we will find that there are in fact any number of bends and changes of direction where we had drawn only a perfunctory line... the line that took us straightaway to our destination has to become more tortuous, perhaps even turning back on itself as it traces a previously unrecorded bay or inlet. (Lindsley, 1997, pp.25).

Initially the line I drew bore a close visual relationship to those I had produced on the experimental excursion *LOST in Dorset*. It was diagrammatic and clumsy (I was standing whilst holding an A4 sketchbook and drawing),

and sparse. The drawings and brief annotations tended to point at things: ‘bushes—scrub—half-hidden lamp post—first view of the balustrade’ (from the sketchbook *Russell Cotes Drawings, Sept-Nov 2006*). As I continued towards the new extension I also began to record thoughts: ‘No windows but made to look like part of the house. A non-functional building?’ But by the time I had rounded the corner at the point that East Overcliff Drive becomes Russell-Cotes Road, I had begun to adopt a form of continual line drawing that is a staple of British art school pedagogy, particularly as an approach to observational drawing.

The emphasis of this exercise is often placed on removing the observer from thinking about the image being produced in order to focus on coordinating a *movement* between eye and hand. As the eye traces an invisible path along the contours of the figure or object under observation, the hand keeps pace, maintaining continual contact between the drawing material and the paper (or other support). The fluidity of this relationship is dependent on a disassociation from any form of accurate representation of a ‘thing’ on the paper. Within this tradition of drawing pedagogy, students may also be asked to work without looking at the paper to further remove their dependence on conveying a likeness, or literal representation, in other words in focussing too closely on the depiction and not on the act of observation and movement, perhaps similar to the way in which Paul Klee describes:

Shortly after the application of the pencil, or any other pointed tool, a (linear-active) line comes into being. The more freely it develops, the clearer will be its mobility. (Klee, 1961, p.103)

The line that Lindsley describes begins in the elevated position of the Modern cartographer, but as it moves towards greater accuracy and shifts in scale closer towards 1:1, the edges it purports to describe become increasingly uncertain; progressively fuzzy. As the focus moves from pictorial description toward the tracing of visual and ambulatory movement, there appeared to be echoes of Robert Smithson’s account of ‘surveying’ and ‘scanning’, in which the perspectival view and the aerial grid which circumscribe space ‘within a fixed and sedentary position’ or as ‘enclosed within certain determinate

shapes' give way to 'the "uncertainty" that walking over the terrain entails' (Casey, 2005, p.14).

Back on the corner of Russell-Cotes Road and Overcliff Drive, these walking inscriptions were about to turn through the entrance of the gallery towards the interior, where relationships between the line, edge and movement would become more elaborate. Inside the museum I continued to enact a process of mapping through a series of what I later described as 'walking drawings'. I saw this act as performing two functions: an embodied or physical marking out through walking and re-walking the site and a way of spatialising the site, setting things out side by side by inscribing a line between, or around them. At the time one of my key concerns was the sense that in this linear and mobile mapping I was making decisions either to set one thing aside from another or to unite them in one continuous stroke in a form of discrete taxonomic ordering. Examples might be found in the drawings, through lines that connected an arch or decorative door frame to a heating duct or the shadows cast on the floor of a room, or that described both the cabinet and the displayed objects with the same pressure and continuation of line (fig. 3.8, i-iv). Drawing made me increasingly conscious of the way in which the architecture of display was amalgamated within the existing fabric of the building, the decorative wall stencilling became rephrased in the graphic language used to support the public information displays or even printed on the modern blinds that prevented too much direct sunlight from damaging the artefacts.

In the catalogue text I prepared to support the work I described these as an overlapping of histories, one of a series of separations. The logic of the museum and the collection seemed to demand taxonomic divisions and hierarchies to separate function from collection, historic place from contemporary museum 'space'. As a visitor one is navigated between the apparently discrete spaces of the museum: the Red Room, the Study, the Mikado's Room. Like many other visitor attractions, some of these have been designed to simulate, or provide an impression of, having some original and significant function. But whilst some are recreations that gesture towards some authentic historical usage, others are presented not as dwelling spaces

but as room-sized cabinets or displays. Still others document restoration work by revealing, layer by layer, the complex veneers of material that has been inscribed, coated and covered over through the hundred years or so since the residence had been built. Most of these rooms came with some textual reference as to the role they played in this grand Victorian residence—perhaps as a bedroom for visiting guests, a study or reception. Working inside the museum I became aware that this process of walking and mapping had the potential to re-order these taxonomies and classifications, and reinterpret the curatorial logic that presented, say, the artefacts in terms of geographic origin spatialised along a timeline.

Whilst I walked and drew I had become progressively aware of how I handled the materials I was working with. I had begun to develop a way of holding myself and my materials in order to proceed more fluently. I had also begun to establish which materials seemed to be more amenable to making swift gestural marks, swapping cartridge paper for smooth drafting film. In this orchestrating of body, material and movement I tried to make the physical act of drawing more effortless, so as to reduce conscious attention to the materials. It was an effort to reduce the speed of response between eye and gesture, and a way of coordinating' the two. These drawings then progressed over a couple of weeks, and on each visit I continued to build on this rhythm of walking, scanning, tracing.

Wandering & Desiring Lines

Drawing is the opening of form. (Nancy, 2013, p.1)

In his book *Lines: A Brief History* (2007) anthropologist Tim Ingold makes a distinction between a 'walk' and an 'assembly'. Ingold, observes, by way of Paul Klee, that: 'the line that develops freely, and in its own time, "goes out for a walk" [...] And in reading it, the eyes follow the same path as did the hand in drawing it' (Ingold, 2007, p.73). In order to illustrate this he refers to a line traced in the air by the stick of the Corporal in Laurence Sterne's *The Life and Opinions of Tristram Shandy, Gentleman*. Ingold notes that were this

gestural line to be reduced to a series of points, and each of those connected by a straight line, the complete pattern no longer forms the path of a 'walk' but a welded together construction; an 'assembly'.

Once the construction is complete there is nowhere further for the line to go. What we see is no longer the *trace of a gesture* but an assembly of *point-to-point connectors*. The composition stands as a finished object, an artefact. Its constituent lines join things up, but they do not grow or develop. (Ingold, 2007, p.74-75)

The perfunctory-ness of these connectors endows the line with a completeness, a joined-up-ness, rather than the open-ended possibilities of the walking or gestured line.

In the work undertaken at the museum, the line on the sketchbook pages progressed in tandem with the movements of my body as I walked, rotated and scanned the extents and edges of the museum, and in doing this I also I traced, marked, scratched and scribbled marks onto the surface of the paper I carried, adding and reducing of pressure on the drawing material as I progressed around the museum. Artist Maryclare Foá's work also involves walking whilst drawing. She describes the relationship between the observing eye and the gesturing hand as the 'performative recording of that which is seen or imagined' (Foá, 2011, p.6), one in which the act of drawing conjoins with, and is conditioned by, the environment in which it occurs (p.1). Whilst working outside Foá also becomes aware of the role that being in movement plays in the drawing process, not only in the physical articulation of head and hands but also in the shifting of the body. In her *Walking Drawing* works (2004), she documents the processes of walking whilst drawing using a homemade harness that holds her sketchbook and a video camera at chest height (Foá, 2011, p.58). Foá's focus is on the description of the passing landscape, which, as she moves through it appears to offer 'a continually fresh subject' (ibid.) and a new set of relations. But this is not the only way in which Foá's environment affects her work, as she explains:

The drawings themselves were both clumsy yet in parts also fluid, combining the out-of-control skidding, scribbling and scratching of

my pencil with some determined stabs attempting to capture motion and structure an image. In the process of this work I found that the environment influenced my choice of subject while the motion affected my physical condition. The motion also affected the form and the pressure of the drawn mark on the paper, evidencing my body's motion and the surface over which I travelled, but there was no influence on the environment that I moved through from either my presence or the work that I made. And because I walked swiftly, there was no interaction with the other (Foá, 2011, p.58).

Despite these shared approaches, impulses and environmental influences, I not entirely committed to the belief that she has no influence on the environment she walks through, and that she remains separated from 'the other'. To extend these differences just a little I want to briefly pursue perspectives put forward on drawing put forward by Ingold (above), and by philosopher Jean-Luc Nancy.

Both Ingold and Nancy point to the élan of the drawn line—the open potential created in the gesture that moves outwards in the air or on the paper, whilst philosopher Jean-Luc Nancy also describes the double movement that arises in the instant of drawing, one that not only proceeds from self but also opens out towards self (2013, p.25). Ingold's draws his theorisation of the line that traces out across the surface from distinctly Deleuzian ground by adopting Gilles Deleuze and Felix Guattari's concept of 'lines of flight' or 'lines of becoming' along which they see life as being lived. 'Lines of flight' do not connect things to one another, but rather 'pass... between them, carrying them away in a shared proximity in which the discernibility of points disappears' (Deleuze and Guattari, 2005, p.294). In this respect a 'line of becoming' is a not defined by origins or ends, since it is always already in flow, and, since life is open-ended 'its impulse is not to reach a terminus but to keep on going' (Ingold, 2011, p.83). This way of conceptualising the line as a movement rather than a connector between termini, is important in Ingold's broader theorisations of the concept of environment, and he outlines his view by imagining the 'entangled bank' described by Charles Darwin in *The Origin of Species*:

Observe how the fibrous bundles comprising every plant and bush are entwined with one another so as to form a dense mat of vegetation. On the bank, 'the environment' reappears as an immense tangle of lines. (Ingold, p.84)

This view of the environment would not separate Foá's 'subject' (for which I read subject matter), from her presence. Instead it weaves together countless trajectories of plants, animals, humans and things in flows and counter-flows. Again through Deleuze, Ingold represents us with a fluid life-space, which even if it is devoid of apparent 'life' is in continual modulation. This life-world is not defined in terms of points or objects but in sets of relations:

[H]accencies are not *what* we perceive, since in the world of fluid space there are no objects of perception. They are rather what we perceive *with*. In short, to perceive the environment is not to look back on the things to be found in it, or to discern their congealed shapes and layouts, but to join with them in the material flows and movements contributing to their—and our—ongoing formation (Ingold, p.88).

Like Ingold, Nancy directs us towards the vitality of the gesture and to its non-closure. The word *drawing*, he notes, implies both act and force, 'where the sense of the act, the state, or the being in question cannot be detached entirely from a sense of gesture, movement, or becoming' (p.1). The act of drawing is not just the desire to show but also the act of finding, and as such drawing does not simply reproduce, but produces *anew* 'an idea, a thought, sense or truth' (p.11). Ingold, too, points to this incipient moment in which drawing both *draws* out and *seeks* out form:

At the same time that the gesturing hand draws *out* its traces upon a surface, the observing eye is drawn *into* the labyrinthine entanglements of the lifeworld, yielding a sense of its forms, proportions and textures, but above all of its movements—of the generative dynamic of a world-in-formation. (Ingold, 2011, p.224)

Yet Nancy also turns to the *self*-forming moment, the double movement in

which the act of formation discovers itself. The form—the idea—that becomes present through the act and gesture of drawing remains in suspension, it is always ‘taking shape’ rather than becoming complete, and it is in this tension that Nancy identifies the pleasure of drawing (Nancy, p.26). He offers the proposition that this sense of pleasure is ‘[n]othing other than self-affection... the relation of the self, the subject, or becoming subject... of a “renewed self-desiring,” while displeasure is the self-affection of “self-withdrawal” (p.27). It is through this double movement of desiring and withdrawing that Nancy sees the ‘self’ as being formed ‘in the expansion and retraction of its being’ (p.28). If this feels a little too subject-centred, perhaps too introspectively removed from the myriad trajectories in which Foá is entwined on her journeys down Charing Cross Road, then Nancy provides this alterity by exploring pleasure *as* relation.

Relation is not exactly transitive—it is transitivity, transit, transport. It is the effect [*l’efficace*] of one subject toward another, with its reciprocal necessity, and it thus involves the transport between them of some force, or form that affects them both [*l’un de l’autre*] and modifies—or at least modalizes—them both [*l’un par l’autre*]’ (p.67).

Self-forming, becoming subject, is a relational force, an opening between inside and outside, and it is through this force as that the subject experiences itself as distinct. Nancy sees this alterity as being essential to subject formation—a tension between self and experiencing self as other, perhaps here through the rhythmic acts and gestures of drawing, and for Foá it may offer the ‘other’ that she was searching for, although not as a stable entity but as a continuous interplay between becoming and presenting. So, the journey taken by the observing eye is one that travels along lines of movement and relation rather than as a discrete connection between the eye and the observed object. As such one might say that the movement is not one that advances towards completion, but one in which the double movements that open out and draw back are both the opening of a process and the (pro)creation of form.

Tracing and Assembling

March 3rd, 2007.

Just finished working on the R-Cotes drawings — transferring information from observational drawings onto large scale map.

Recorded a few thoughts to MP3

Main Areas

OVERLAP LAYER — Layers and skins — too much of a separation — skins of an onion — these are less layers but more interconnected — overlapped (fusion?)

CUT THROUGHES — Cutting through tracing paper to create depth relationships ↓

Cut-out pieces

LINES — BOUNDARIES,
SILHOUETTES — TERRITORIES etc.

MOVING TOWARDS THE EDGES —

Allowing drawing to grow ~
related to presentation (RC parameters)

NO RISK? — Not enough 'play'

Images are growing in density but need to develop — need to take on different WAYS of drawing.

BOOK-BOUND OBSERVATIONAL DRAWING

SCALE

Seems to be an emerging theme

> As I have become more used to the space, the drawings have significantly changed in SCALE.

Drawn objects have become bigger

WHY?

> Also SCALE as related to other pieces — perception and scale — Cpt. Lawson piece — idea of approach to an island, Idylla etc.

Perhaps need to look at scale in more detail.

It also affects the way I have approached the mapping of the RC from inside — rhizomatic? diagram of interlaced (?!) forms

[Filigree? What is the name for that complex meshing in decorative screens? Perhaps still not a good metaphor.]

> The coalescence of 'stuff' may be hard to describe

(1) - overlapping suggests one dominant.

(2) - layering suggests similar + there is a separation of the different elements...

Tenuous but a growing drawing? An unfolding? Narrative.

(Personal Notebooks, 3rd March, 2007.)

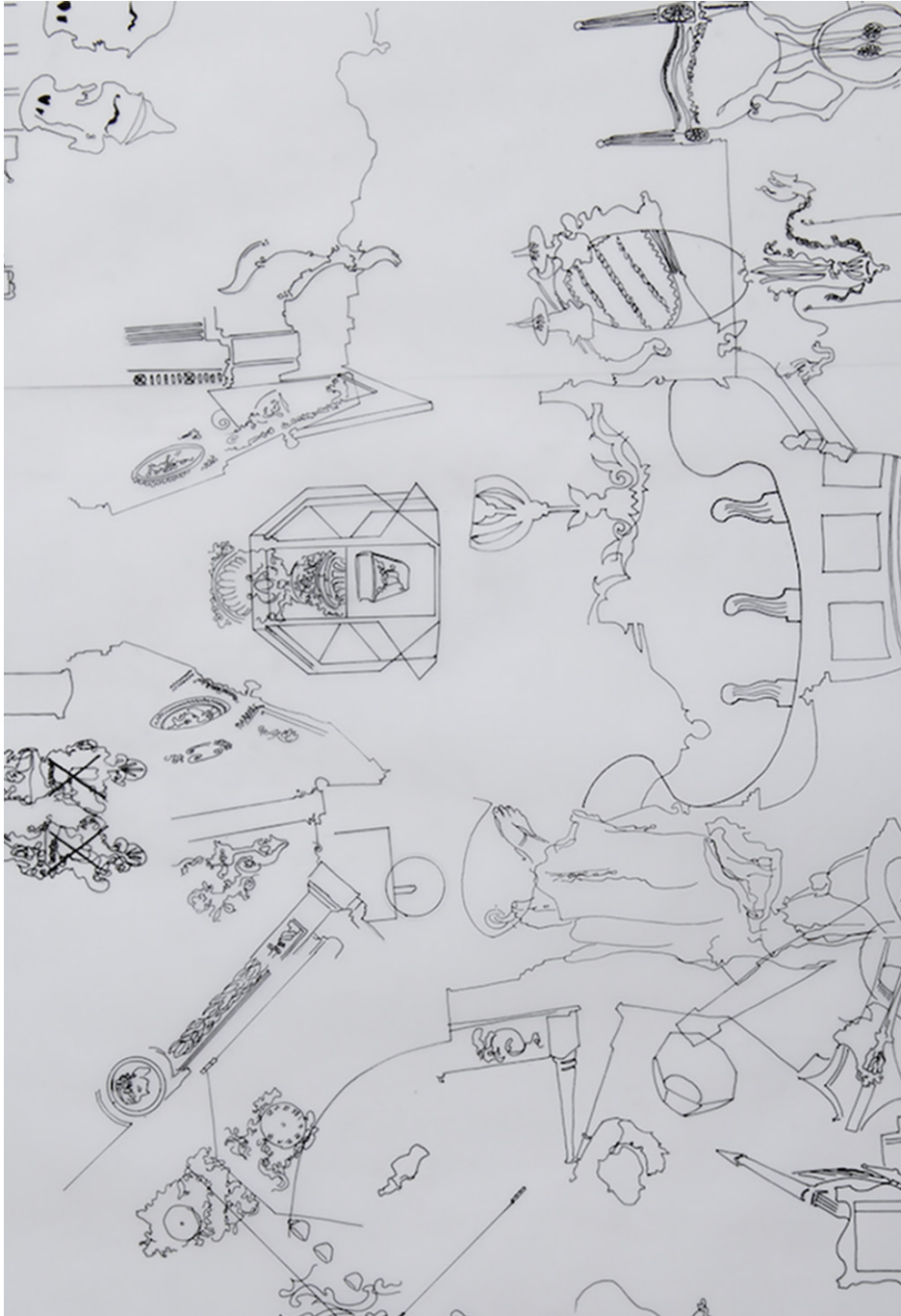

Fig. 3.9: Assembling tracings for *Meeting Place*. 2007.
Ink on drafting film

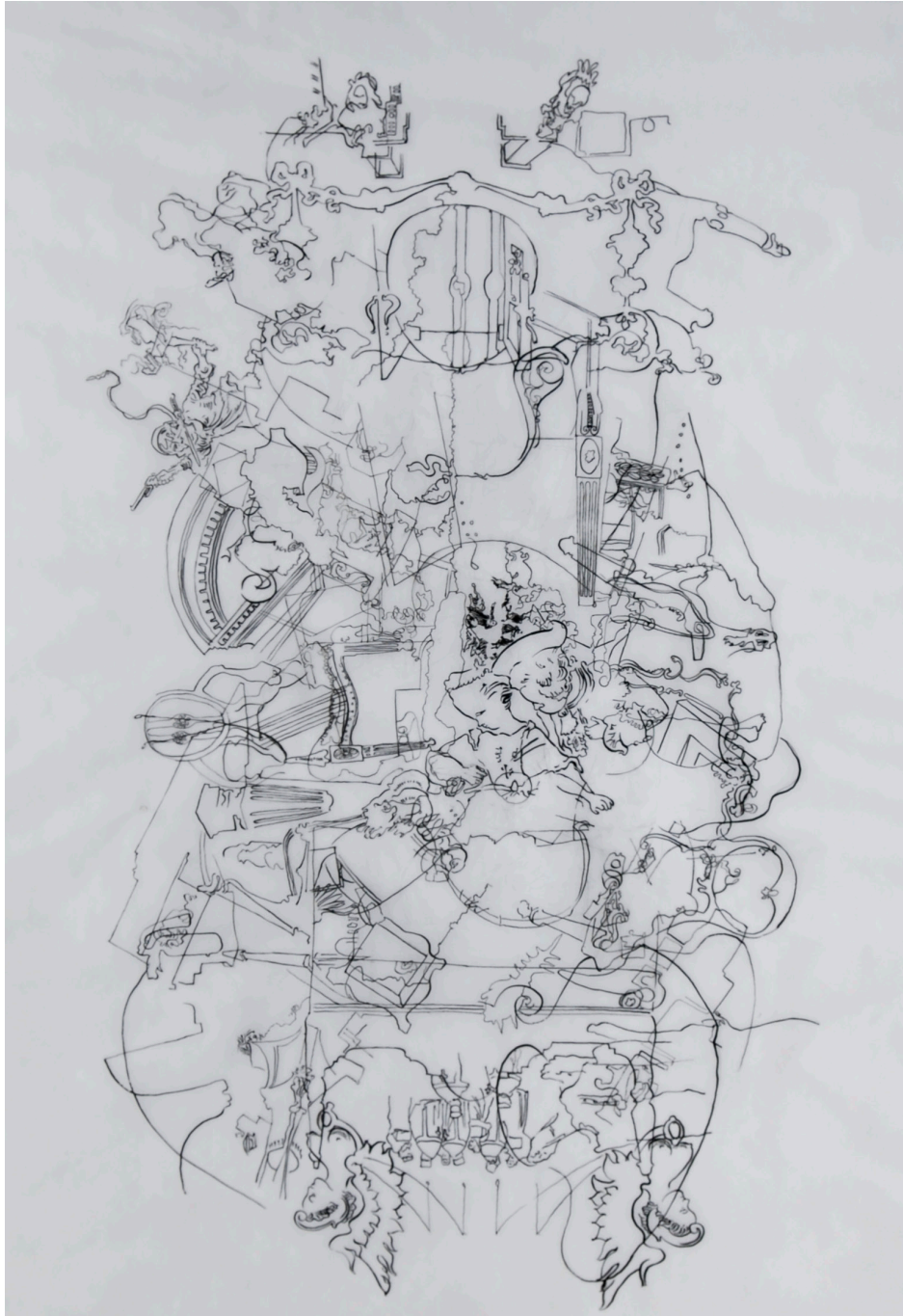

Fig. 3.10: Tracings for *Meeting Place*. 2007.
Ink on drafting film



Fig. 3.11:
Objects in
the Russell
Cotes Museum
and Gallery
collection



Fig. 3.12:
Objects in
the Russell
Cotes Museum
and Gallery
collection

Ingold might, perhaps, describe the map-like scribbles that emerged at the museum site, as a 'sketch map' (2007, p.84), one whose immediacy develops in the context of a narrated journey, the following or describing of a flow of movement. But this unfolding line would be packed up and carried with me back to the (seemingly) less immediate conditions of the studio. Here these lines would, eventually, be traced and assembled in more elaborate constructions some distance from the museum itself. In the process the work would attempt to take on a more comprehensive representation of the museum by incorporating symbolic references to the collections of artefacts that stood in for the colonial travels of the Russell-Cotes.

Back in the studio I am no longer looking for the flow of the line in the edges of a door or cabinet, but I am following it in the tracing gesture that takes one image and brings it into relation with another. In a makeshift studio a collection of drawings produced on site and a number of photographs taken of various rooms, objects and decorative embellishments in the museum were brought together (fig. 3.9 & fig. 3.10). Away from the site the immediacy of earlier performative drawings gave way to a different kind of performance, the shuffling and organising of images on a desk and on a light-box; the layering and tracing of lines from one sheet, or one image, onto another. This performance is as much an 'intertwining of vision and movement' (Merleau-Ponty cited in Foá, p.59) as both myself and Foá find in the walking/drawing experiences on the streets of London and Bournemouth, but for this moment my attention is not on how to hold the materials or make marks at the same time as I perambulate the museum, but on cutting sheets of drafting film, sifting through and moving around photographs, stepping back from and back into the illuminated piles of images on the light-box, and gradually rolling out the larger tracing that is coalescing in front of me.

Returning to Ingold's (2007) discourse on maps and linearity, he describes the construction, or marking out of points and conjoining lines as an 'assembly', a form he associated with cartographic science rather than informal and immediate map-making. Whereas the lines made whilst walking contained within them the gestural openness of a 'sketch map' (p.85) that moved along a line of experience, the tracings that now took place in the studio moved



Fig. 3.13: Untitled collage, 2007.

towards a construction, they began to form a pattern. In doing so one might say that this new drawing was directed towards a composition rather than the tracing of a gesture. Ingold's distinction between the '*walk*' and the '*assembly*', is central to his thesis that modernity has reduced our perception of place from an open-ended and interwoven passage of movements and experiences to one of destination-orientated transport, route-plans and pre-composed plots:

To an ever-increasing extent, people in modern metropolitan societies find themselves in environments built as assemblies of connected elements. Yet in practice they continue to thread their own ways through these environments, tracing paths as they go. I suggest that to understand how people do not just occupy but inhabit the environments in which they dwell, we might do better to revert from the paradigm of the assembly to that of the walk. (Ingold, 2007, p.75)

Sketch maps, Ingold tells us, do not claim to represent territories and for that reason they are not generally framed or bordered. Their central features are the lines along which narratives unfold, rather than the spaces around them (p.84). Cartographic maps, on the other hand, (which are *assemblages* of lines), articulate territories. They enclose rather than open out. And yet, as Ingold even acknowledges, this is *not* how they are often used. We draw on them, gesticulate over them, and form conversations around them (p.85). To that extent at least, maps appear to have lives beyond simply what they *show* (Del Casino and Hanna, 2005; Crampton, 2009; Kitchin, Perkins and Dodge, 2009).

Indeed Ingold's illustrations of cartography are charged with a very particular separation between the winding experience of the wayfarer who 'knows as he goes' (Ingold, 2007, p.89) and the abstracted and bureaucratic overview of the cartographer, illustrated by the naval high command, who '[d]riven by imperial ambition', treats the world as 'a global system of co-ordinates', and the map as 'an instrumental calculus of point-to-point navigation' (p.77). Ingold's illustrations provide an idea of cartography as a way of thinking, rather than practicing: a map of the Skælbækken stream from a 1920 survey atlas of the Danish-German border becomes a diagram

for the way cartographers have sought to rationalise the environment, divide it into segments and territories. And yet for those studying how we make *use* of maps in navigation such as Barry Brown, Eric Laurier and Mark Perry (Brown and Perry, 2001; Brown and Laurier, 2005), maps can be said to be both socially constructed *and* reconstructed each time they are used in which navigating involves checking with those around us, sharing stories and using the map itself as an expressive tool. Even if we consider the map simply in terms of its diagrammatic form there is life beyond the enclosure it seems to represent. Indeed Kitchin and Dodge (2007) argue that our idea of what a map *is*, is constantly reaffirmed through its use: ‘how do individuals know that an arrangement of points, lines and colours constitute a map (rather than a landscape painting or an advertising poster)? How does the idea of a map and what is understood as a map gain ontological security and gain the semblance of an immutable mobile?’ (p.335). Kitchin and Dodge answer these questions by asking us to think of mapping as a series of *practices*, and whilst maps seek to appear stable inscriptions, they are, in fact, ‘a co-constitutive production between inscription, individual and world; a production that is constantly in motion’ (ibid.).

My own urge towards composition and assembly was also guided by an idea of the work in terms of an outcome, a coherent image. Working with tracings of the original drawings made on site, there was a sense that these abstracted from the immediateness of that embodied practice ‘on the ground’. Initially I proceeded to layer those images, created whilst walking the site, on top of one another, in a way that might resemble a conventional map. I fitted the lines together, considered how the things they described might be placed so that they took on the likeness of a chart. I accepted that each original drawing seemed to present the museum architecture at different scales, and the resulting drawing tried to accommodate for that. The work evolved not *as* a map, but as a diagram that seemed to envelope an idea of mapping. In reassembling existing drawings into a symbolic structure such as a map or island, the resulting image could be described in terms of the desire to effect a form of completeness; it would become a *representation* of this encounter,

a frame, vignette or decorative 'motif'. This, I thought, would be a move towards resolving the complex meshing of curatorial and architectural histories, a reference, perhaps, to the overlapping of public museum and private dwelling.

To do so required a new configuration of body, materials and (working) space. I borrowed a light box, bought a large roll of drafting film, shifted a series of tables in a small spare room that doubled as a study. I bought in tapes, bulldog clips and wall fixings to pin up the excess film since the table and the light box were both roughly A1-sized and the fragments of linear drawings suggested that they would exceed this scale. In short I spent a while sorting, moving, acquiring and fixing objects, furniture, tools, materials to constitute a space in which I could progress the construction of this map/island. The A4-sized drawings were layered under the drafting film and the lines traced through. I moved the pieces around until I found an orientation that I felt happy with. I worked by moving around the drafting film, which was now secured to the furniture. Whilst the image remained at the centre I laid out drawing materials, inks, tape etc., around the sides. Working this way, with the work on the flat, illuminated by a light box, everything was orchestrated from periphery towards the centre. At first I re-composed the small A4 drawings into the larger image using the same diagrammatic logic that would allow the final work to serve as a map. I joined rooms to one another by finding points at which the lines in the initial A4 tracings might conveniently be joined to create the outlines of a room, viewed from the cartographic convention of an abstracted view-from-above, remaking the drawing as a floor plan. In doing this I also recalled the floor plans that stood in the entrances to the rooms, indicating where significant museum artefacts and objects were placed. I began to connect this way of diagramming the space to my own artistic endeavours, drawing these ideas into the practices of tracing.

Separately I began to collate a body of photographs I had also taken at the museum, of decorative embellishments on furniture, architectural details and the contents of museum cabinets. These allowed new works to move in another direction, one in which I attempted to create hybrid architectural

forms by flattening the images into silhouettes, cutting and pasting them in different combinations (fig. 3.10). Later these too were traced onto drafting film. Alternations between processes that seemed to be working in very different directions also began to affect each other. Photographs of the decorative cartouches, ribbons and other moldings that edged the furniture or ornamented the architecture were enfolded into the line tracings and floor maps. But there was a sense that the singular occupation with the architectural qualities of the site was not grasping at a history of the material it drew together, and was, instead, offering a depoliticised representation of the collection as simply the adventurous but innocuous products of Victorian souvenir gathering, in which places such as Japan are presented as curious and exotic stop-overs on a global tour. Now I wrestled with a feeling that *these* representations of places should be recognised as more than the curios accumulated on grand and global Victorian excursions.

Echoing the highly decorative frames and ornamentation of the furniture, the picture frames and architecture a new image was produced in which the traced lines of the map making were enmeshed within a vignette or cartouche, that appears to present the world as both map and picture. Leaving a large space in the centre appeared to suggest an emptied space, a 'tabula rasa' on which the colonial vision of the world might be inscribed (fig. 3.14). Whilst this removed the immediacy of the drawings made directly in response to site, the processes involved in the construction of this vignette brought together an accumulation of images, marks and lines as a means of interweaving several possible narratives that were aimed towards the geographical, topographical and cultural representation of this particular site.

As a series of assemblies these works for *Meeting Place* moved through phases, at each event attempting to take up new concerns, images, or information. The works seemed to be creating associations with particular forms: a map-image, a floor plan-image, a cartouche-image without fully becoming these. As constructions created from tracing the points and lines of a pre-existing set of images we might be inclined to think of how, to use Ingold's terms (Ingold, 2007), they no longer describe a journey but rather describe a series of point-to-point connections between destinations. Certainly the works

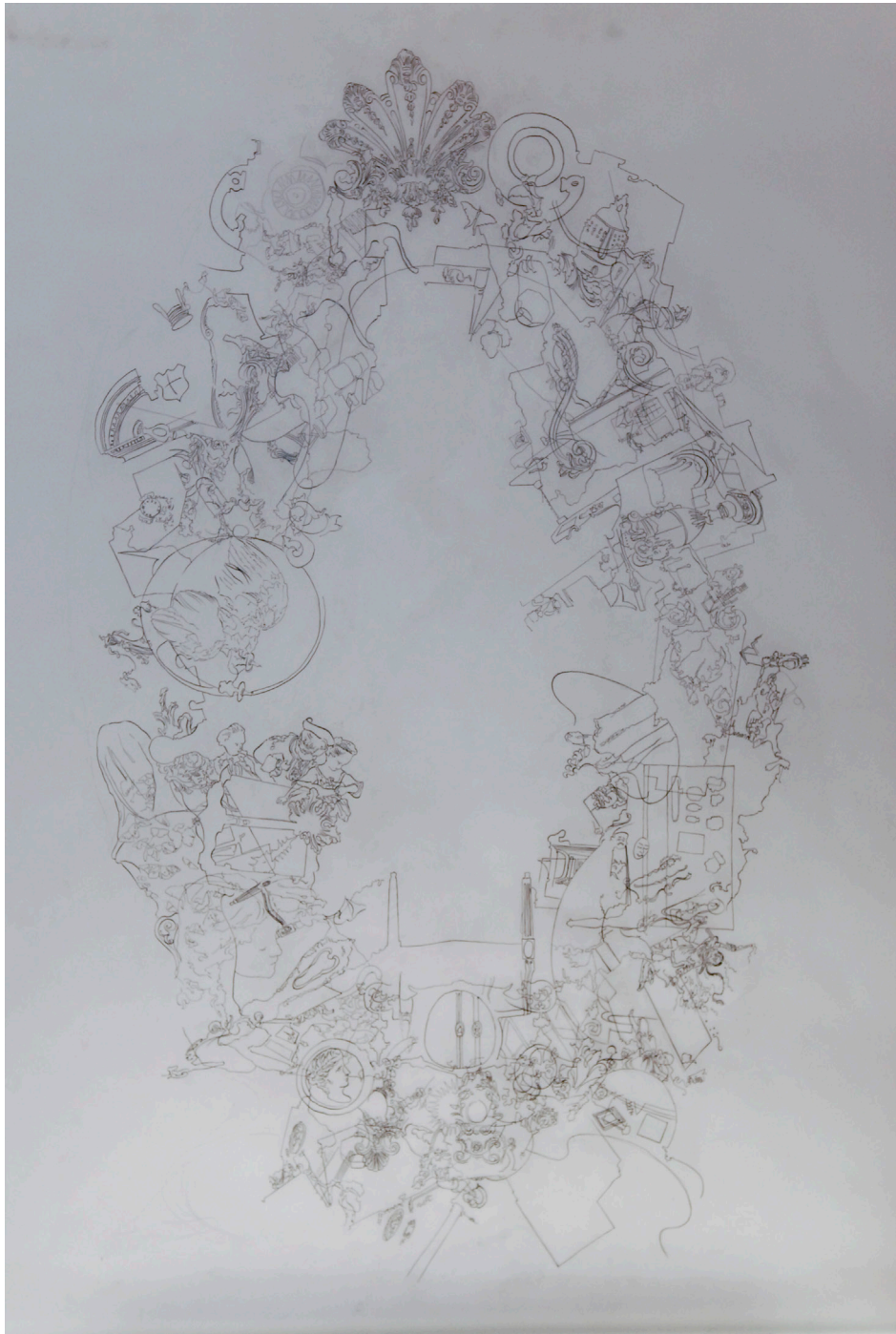

Fig. 3.14: Large drawing for *Meeting Place*. 2007.
Ink on drafting film.

were produced from predefined images, and at various points were directed towards a goal or endpoint, but they appeared to unfold in ways that were contingent rather than predetermined. Of course there are a number of key differences between my approach to creating images, which gesture towards mapping, and the methods of cartographers whose work requires attention to a particular level of measured detail. But for Ingold it is not simply the form the image takes, but its propensity to closure. Painting, for example, is similarly constrained by the ‘totality of composition’, and the ‘logic of the all-over’, unlike the drawn line which is free to respond to ‘the present conditions in its vicinity rather than to any imagined future state (Ingold, 2011, p.220). And Ingold is not alone in seeing these cartographic *assemblies* of lines as an organising and territorialising system directed towards enframing and stratifying space. Indeed some of the art historical discourse that surrounds the *counter*-cartographic practices of artists, particularly in the latter part of the twentieth century, often draws on a narrative of disrupting and *un*-framing the cartographer’s omniscient view-point, often in oppositional and occasionally pugnacious terms.

Critical Cartographic Perspectives

Although art historian Irit Rogoff has changed her perspective on cartography of late (Rogoff, 2010; see also Rogoff, 2013), in *Geography’s Visual Culture* (2000)—her comprehensive exploration of the interstice between geography and art—Rogoff argues that, “the un-mapping, re-mapping and counter-cartographies to be found within contemporary art practices revolve around the structures and signifying systems by which knowledge is organized and conveyed” (Rogoff, 2000, p.73). Like numerous commentators following J B Harley (1989), she is questioning the claims to neutrality, legitimacy and authority often made in the name of cartographic science, and presenting, as a counterpoint, the works of artists whose subjective repositioning of the practices of map-making might be described as reinserting the personal-political into the empty structure of the cartographic grid.

Rogoff begins by deciphering artistic and scientific maps in terms of ‘sign

systems and rhetorical codes' (p.79) by examining how the persuasiveness of cartographic grammar: 'in masking difference and producing homogeneity' (p.75). Turning to the work of artist Simon Patterson, Rogoff describes how the assumed logic of cartography is reframed in an encounter between different knowledge structures. In Patterson's work *The Great Bear* (1992), he uses the London tube map as the basis from which to construct a series of interlocking taxonomies of professions and disciplines by changing the station names for those of famous historical figures, spaced along lines denoting, for example, philosophers or comedians. Rogoff sees this work as bringing into contrast two competing structures through which the viewer reads 'the location of mapping with all of its hidden orders and assumptions, and the supposed division of human activity into spheres and disciplines and professions and historical periods — and... set[s] them to work one against the other' (p.77). There is, in this description, a prevailing sense that artists working with maps challenge the 'naïve practices' of cartographic science, and revealing undisclosed power relations by introducing complex and reflexive subjectivities (Stott, 2004; Holmes, 2006; Boyd Davis, 2009; McCarthy, 2014). This view is supported by the very term *counter*-cartography in which the fixed and immutable knowledge structures of cartographic science are disrupted by the introduction of alternative forms of spatial 'knowledge'.

In a recent issue of *The Cartographic Journal*, Ruth Watson provides a list of twenty-four exhibitions from 1977, in which contemporary artists have taken cartography as their main focus (Watson, 2009). As she admits, the list is not exhaustive. What is remarkable, perhaps, is that no similar list could have been drawn up in the first half of the twentieth century or before. Similarly, the art historian Nicolas Bourriaud opens his catalogue essay for *GNS/Global Navigation System* by declaring:

“Maps, charts, satellite images, still photos, samples of all kinds, social studies, diagrams and tables—never before has the notion of geography had as much importance in art as it does today. We would have to go back several centuries to find artists exploring the physical world with as much energy and enthusiasm.” (Bourriaud, 2003, p.9)

Within art, an explosion of interest in all things cartographic has been related both to the challenges, and perhaps opportunities, provided by locative technologies. The freely available use of global positioning data, coupled with the growth of surveillance systems such as Closed Circuit Television (CCTV), has engaged artists in various explorations around the ways space is represented. Yet the use of GPS and CCTV have also spawned new forms of regulation and social control (Cosgrove, 2008, p.176; Steyerl, 2013, p.166;) that artists and activists, such as the Institute for Applied Autonomy and Area Chicago, have sought to disrupt by subverting or reappropriating the original purposes of these systems of power and authority, or by returning power to communities through participatory practices that use these technologies (Thompson, 2008, p.114-115). And the presumed neutrality and accuracy of locative media has been critiqued through practices such as Jeremy Wood (fig. 3.15) or Christian Nold. The language that describes these counter-cartographies in publications such as Janet Abrams and Peter Hall's *Else/where: Mapping* (2006), and more recently in Hans Ulrich Obrist's *Mapping it Out* (2014), is often one of resistance and subversion.

However, since the mid-eighties the conception of cartography as a science that works towards ever more accurate and effective representations of surface-space has been consistently challenged. And whilst Harley's seminal essay *Deconstructing the Map* (1989) moved to reconsider cartography as a power-laden, rather than an objective pursuit, later writers such as Denis Wood (1992), John Pickles (2004), Jeremy Crampton and John Krygier (2005) have moved this argument on by emphasising the selective processes involved in their creation and the uses that are made of them. Part of this shift, according to Kitchin and Dodge, has been the 'production and valuing of counter-mappings—maps made by diverse interests that provide alternative viewpoints to state-sanctioned and commercial cartography.' (Kitchin and Dodge, 2007, p332).

Following from the work of John Pickles and Jeremy Crampton, who have proposed a post-representational cartography in which all maps are understood not just as explanations of the world, but as mediators of the interplay between the world and ourselves, Kitchin and Dodge have sought to



Fig. 3.15: Jeremy Wood, *Traverse Me*. 2010.
Image reproduced with kind permission of the artist.

question the stability of maps: ‘as spatial representations that say something about spatial relations in the world (or elsewhere)’, (Kitchin & Dodge, 2007, p.334). Instead they propose an understanding of maps which is *ontogenic*, that is to say, maps are constantly remade whenever they are engaged with — they are interpreted, translated and made to do work:

As such, maps are transitory and fleeting, being contingent, relational and context-dependent. Maps are practices—they are always mappings; spatial practices enacted to solve relational problems (e.g., how to best create a spatial representation, how to understand spatial distribution, how to get from A to B, and so on). (Kitchin and Dodge, 2007, p335)

The positioning of counter-mappings as somehow in opposition to an ‘establishment’ of cartographic science tends to adopt a view on the history of cartography as being one of a singular teleological mission towards more ‘truthful’ and accurate maps. In doing so, there is a danger of ignoring developments in critical cartography in order to present the authority of the map as antagonistic to the subjectivity of the individual. If we follow Pickles and Kitchin and Dodge’s conception of a de-ontologised map, it is one that is made and remade as part of a co-constitution between inscription, individual and world; whose stability cannot be assumed, but is reaffirmed through its use. Cartography is then recast as an inclusive term for a broad range of spatial practices, and in so doing the status of counter-cartographies as *oppositional* practices becomes a problem in that maps as a whole are no longer envisaged as stable constructs:

...maps emerge in process, through a diverse set of practices. Given that practices are an ongoing series of events, it follows that maps are constantly in a state of becoming; they are ontogenic, emergent in nature... They are never fully formed and their work is never complete. Maps are profitably theorized, not as mirrors of nature (as objective and essential truths) or as socially constructed representations, but as emergent. (p.340)

This relational interpretation of maps destabilises a binary relationship

between counter-cartography and state-sanctioned mapping practices, and it is a point that Rogoff herself returns to in the development of her idea of ‘Exhausted Geographies’, (2010). In a revision of the representational and counter-representational arguments of her earlier work (2000), Rogoff redescribes mapping practices as a tripartite activity which involves a situation, or ‘facts on the ground’; an attempt to resolve these—the cartographic activity; and what she describes as ‘a slippery outcome that operates as an affective economy’ (2010, 00:04:30). She suggests that:

One of the ways in which geography in general and cartography as one of its main languages operate is precisely by constantly producing technologies of insides and outsides... There’s absolutely no way... that we can actually produce counter-cartographies and I think that... the *unthinking* [of] the very terms that allow them to operate as lines of division and containment is what I feel compelled to do. (Rogoff, 2010, 00:32:25)

In my own work there was a sense that the *idea* of counter-cartographies held the promise of becoming concrete stratagems for critiquing the divisiveness of regular maps, by re-inscribing records of subjective experiences as the ‘dataset’ from which each map developed. In many ways this mirrored a logic of ‘division and containment’ which underpinned many of the early stages of research. Beginning with a sense that some creative strategy might be devised and honed as a tool for tackling spatial ‘problems’ made an object of spatial experience and worked on the presumption that the creative act offered a means of critiquing or unveiling something of this experience. Yet now it seemed clear that adopting a process of walking and mapping could not simply be offered as oppositional, or alternative to conventional mapping practices. Instead I would turn my attention to the *practices* of making and, to some degree, mapping—those performative elements that had begun to figure in the way I talked about my work.

A Swiss Sojourn

A gradual movement away from the oppositional positions proffered by some

commentators on counter-cartography, towards an altogether less stable sense of the separation between maps as objects and as practices would begin to coalesce in the works I produced after *Meeting Place*, on a visit to Switzerland. These works were mainly produced in sketchbooks whilst journeying seemed to be a continuation of those much earlier series of drawings made whilst travelling on coaches, a ‘mapping’ of motorway journeys (fig. 3.1). In one way these might be considered visual travel diaries, although they were produced using many of the tactics I had developed during the Russell-Cotes exhibition. But here I did not distinguish between ‘scanning’ and ‘surveying’, as Edward Casey might have it (Casey, 2005, p.14). These moved between somewhat conventional landscape drawings, sketched maps, and storyboards. And whilst they were made initially whilst walking, they continued as responses whilst travelling on the train or (in the last images) aboard the plane home.

In the following section I give thought to these drawings and bodily arrangements as I examine a number of drawings I produced whilst hiking through parts of the Swiss Alps alongside the apparently sedentary experience of moving through, and recording the same landscape by train. Here the question of a literal physical ‘immersion’ in the landscape is considered in relation to what appears to be a distanced and reflective ‘gaze’.

On Representation

So Bergson writes of substituting the path for the journey, de Certeau of substituting a tracing for acts. But consider. In de Certeau’s formulation, a tracing is itself a representation; it is not ‘space’. The map is not the territory. Alternatively, what Bergson writes is: “You substitute the path for the journey, and because the journey is subtended by the path you think the two coincide” (Massey, 2005, p.27).

Following *Meeting Place*, I found myself contending with two new problems. Whilst the initial proposal presented space and place as discrete, if not oppositional entities, the developing theoretical research appeared to strongly contest a separation between the two. Space, in terms of the first framings

of this research was ‘out there’, it was a quality of worldly inhabitation that existed as the potential object of artistic inquiry. Space might equally have been described as being ‘in here’ too, in that there are geographies of the body that can equally be seen as territories to be explored through artistic inquiry, as Mona Hatoum’s *Corps Étranger* (1994) shows quite beautifully. But as ways of describing space, seeing it as an object of study implicitly severs an experience, and perhaps knowledge, of being in space from a knowledge of space by turning space into a distinct and recognisably separate entity—not an involvement *in* but an observation *on*.

The arguments presented within critical cartography that question the ontological security of maps themselves are part of a broader philosophical shift towards an understanding of space as emergent, relational, unfixed, and beyond representational regimes. In 2007 and 2008, these were strongly influenced by a growing awareness of a number of contemporaneous theoretical strands that had developed in relation to questions of space, one of these being Massey’s work *For Space* (2005) and another Nigel Thrift’s *Non-Representational Theory* (2008). Massey and Thrift’s rejection of attempts to collapse space into representation, that is, to a *given*—a pre-existing cognitive structure or conceptual schema, forced a shift in my approach to research through visual arts practice by raising pressing questions about the representational foundations of visual arts practice. Artist and art theorist Barbara Bolt, who stakes out a similar non-representational position in *Art Beyond Representation* (2004), asks:

Why does representation continue to operate as the seemingly unassailable and assumed truth underpinning visual practice? Is it possible, for example, to think our productions outside the paradigm of representation? (Bolt, 2004, p.12).

Questions such as these began to unseat the original assumptions that I might use arts practices as forms of operational strategy, tasked with providing insights into ‘already-constructed place’ (Massey, 2005, p.45). In turn a certain anxiety grew around how I might take account of an increasingly non-, or perhaps *more-than-*, representational understandings of practice

within the research project (Lorimer, 2005). These debates, which had emerged through parallel interests in cultural geography and in particular in the conceptualisation of space in theory, began to shape the way I thought about the environment I was working in as well as the objects I was creating. Along side this Doreen Massey's argument that place is not a quality of space, nor is space a surface across which we travel, nor indeed is it representable as a fixed and discrete entity presented critical challenges the initial premises of the research. Massey's key thesis is that space *cannot* be separated from the temporal, from the on going, simultaneous and contingent flow of interrelations and interactions that constitute worldly existence. She argues that space is un-representable since in order to fix a representation of space one needs to extricate it from the temporal, to remove it in order to analyse it, and in doing so one is moving from space as trajectory to space as a point, a vector or indices. She contends that there is no distinction to be made between place and space. That place cannot be framed as a distinct quality or type of space, since to be in space or place is not to be in a 'thing' but to always be in *process* (Massey, 2005, p.11). Place, for Massey, is simply a way of expressing, against the apparently abstract projections of global space, the security of fixed enclosure:

In the context of a world which is, indeed, increasingly interconnected the notion of place (usually evoked as 'local place') has come to have totemic resonance. Its symbolic value is always mobilised in political argument. For some it is the sphere of the everyday, of real and valued practices, the geographical source of meaning, vital to hold on to as 'the global' spins its ever more alienating webs... Place on this reading is the locus of denial, of attempted withdrawal from invasion /difference... what if we refuse that distinction... between place (as meaningful, lived, everyday) and space (as what? The outside? The abstract? The meaningless)? (p.5).

Finally, Massey uses the story of Hernán Cortés and the conquered Aztec city Tenochtitlán to draw attention to the way that, in telling 'voyages of discovery', we often describe space as something that is crossed or conquered. The sea and the land become a single surface across which we journey,

“places, peoples cultures [are] simply... phenomena ‘on’ this surface” (ibid., p.4). But to think of space in this way is to see those peoples, places and cultures without a trajectory of their own, they are deprived of history; situated outside of the temporal. Since my practical work was conceived in terms of a method for reflecting on the relationship between space and place, on the basis that one might be differentiated from the other, the proposition that place is a construct that *fixes* the vital continuum of spatial processes threatened to put a large hole in the early premises of the research. At this point I abandoned attempts to describe a tension between the ‘familiar’ and ‘unfamiliar’ as if this might imply a relationship between ‘space and ‘place’, and to reconsider the way in which I had initially formulated the research as a reflection on objective entities.

Massey’s processual readings of space can be understood as belonging to a broader philosophical shift away from representational thinking, one that has progressed from the last decades of the twentieth century, predominantly within the arts, humanities and social sciences. Within cultural geography this has been most pronounced in the non-representational, more-than-representational theories advanced by writers such as Nigel Thrift, J-D Dewsbury, Hayden Lorimer, and John Wylie. Some of the guiding principles behind non-representational theory have been sketched out in brief interludes through the likes of Ingold, Kitchin and Dodge, and Massey, whose writings share some similarities in their presentation of the immanence and vitality of spatial experience, and whose propositions often mark a ‘shift in analytic focus from *discourse* to *practice*’ (Whatmore, 2006, p.603). It was through an encounter with these (and similar) texts, and the questions and problems they presented, that the following creative projects developed. Whilst some of the analyses shaped a way of thinking about the way I framed creative experimentation in relation to an idea of space, I still struggled to reconcile many of the results of the practical entanglements with the discourse that was developing simultaneously. A number of the problems arose from issues of representation, and a continuing concern that the work was becoming progressively iconographic. Whilst a good body of the theoretical discourse talked about space in terms of relational engagement, the works I produced

were enclosed within image-making practices that departed from socially-orientated or situated methods of experimentation. What is more, I was accepting a number of exhibition opportunities that had implications on how ‘research’ was conceived in relation to and ‘professional’ activities. These created some friction in the mid-stages of the research, in that they could be argued to be going ‘off-track’, or could be seen as indulging in personal or commercial interests rather than academic research. Yet later this territorialisation of practices into discrete types of practice became, itself, somewhat troubled.

Meeting Place did not entirely conclude my own map-based works, nor did it end a practice that was engaged in the environment. It did, however, mark a departure from a particular way of contextualising practice, and from the assumption that a series of creative interventions perhaps revealed something about ‘the nature of’ space. In effect this was an acknowledgement that space itself was neither entity or container, it could not be turned into the ‘object’ of a creative inquiry, since to do so would require a sense of separation between the ‘lived’ experience of space, a continuous “simultaneity of stories-so-far” (Massey, 2005, p.9) and the world as a discrete and knowable entity. I revisited some of the early experimental works in August 2008, under the premise that whilst *LOST in Dorset* attempted to document the experience of wandering through an unfamiliar landscape, my prior experience of the landscape around Dorset would not enable me to experience any ‘authentic’ sense of dislocation. An opportunity to visit my brother and his wife in Zurich, Switzerland and to travel, both by foot and by rail, towards the Italian border and back again in a near circular route, appeared to provide an opportunity for investigating a far less familiar environment, albeit still a European one, than the landscape close to where I lived, since part of me still cleaved to the notion that the unfamiliarity of a particular site or city would provide me with a more vivid experience from which I could produce a form of emotive cartography.

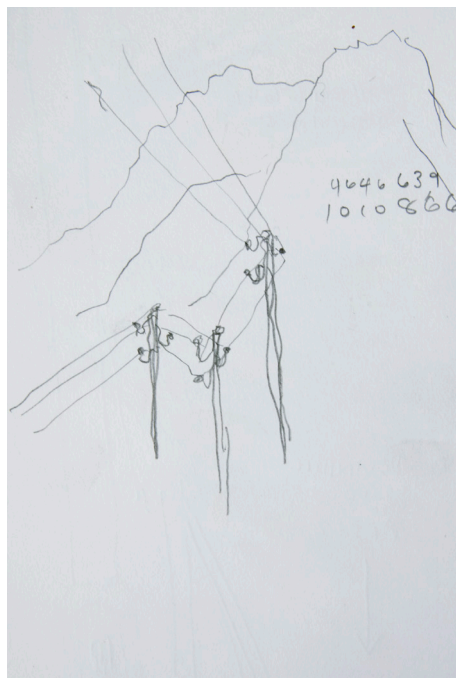
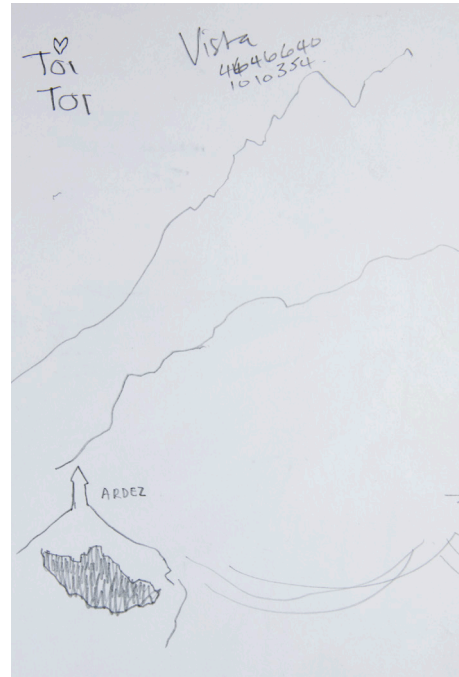
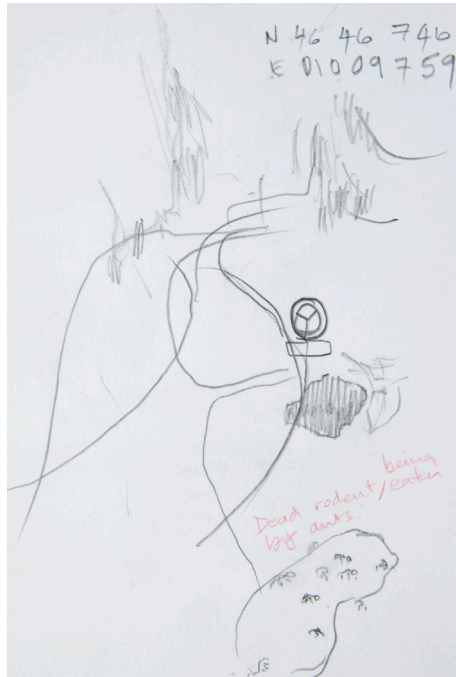
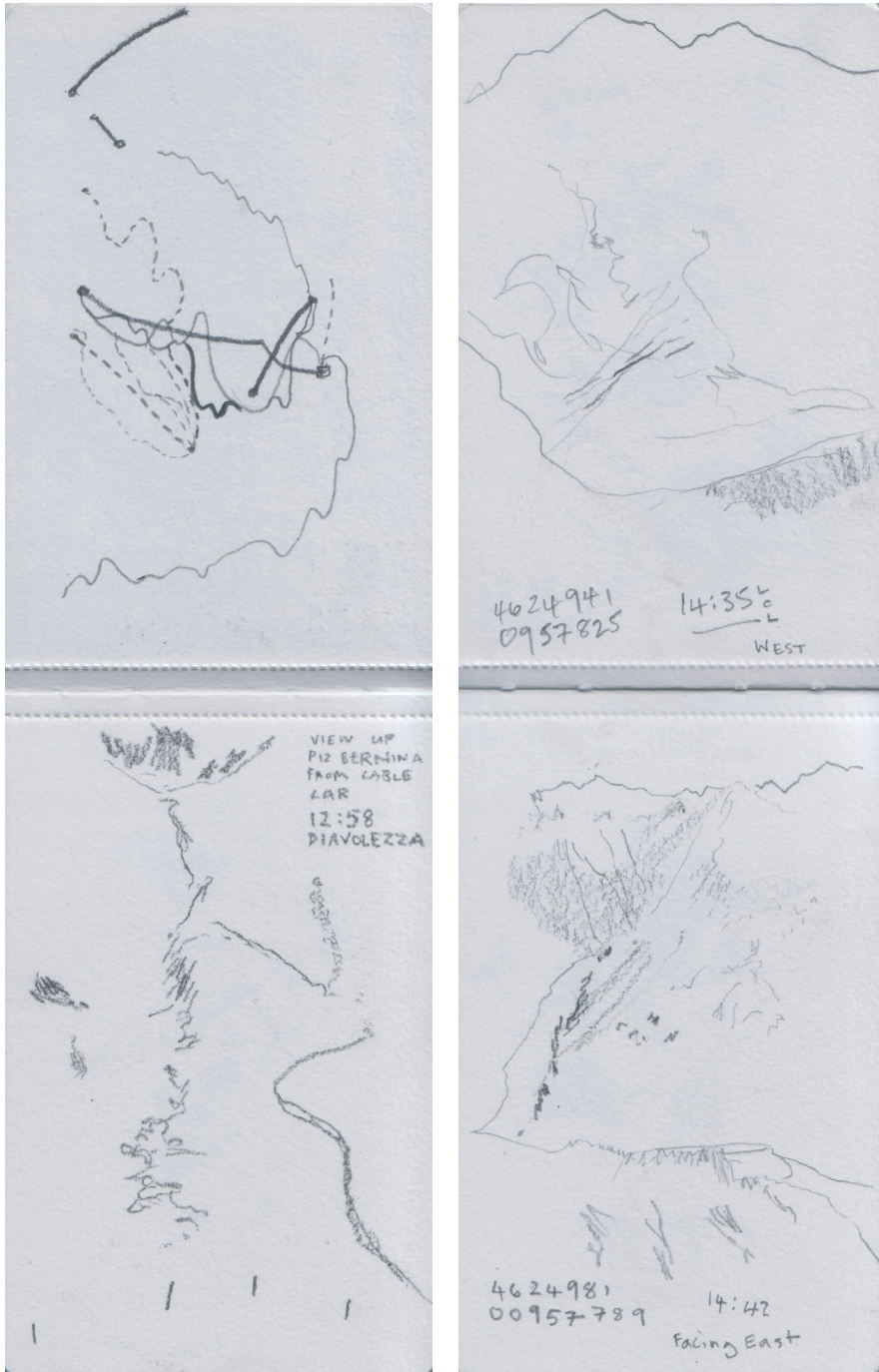
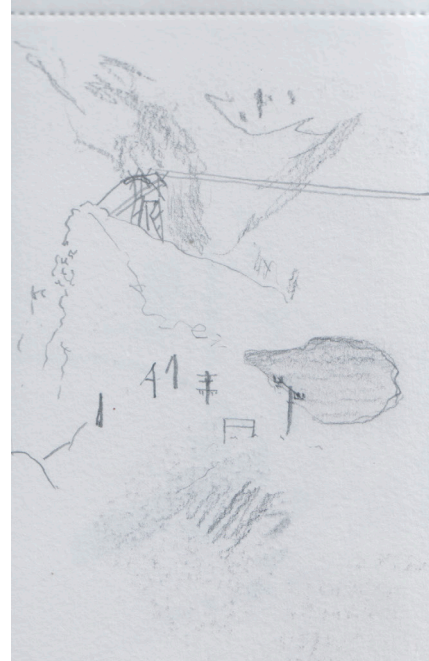
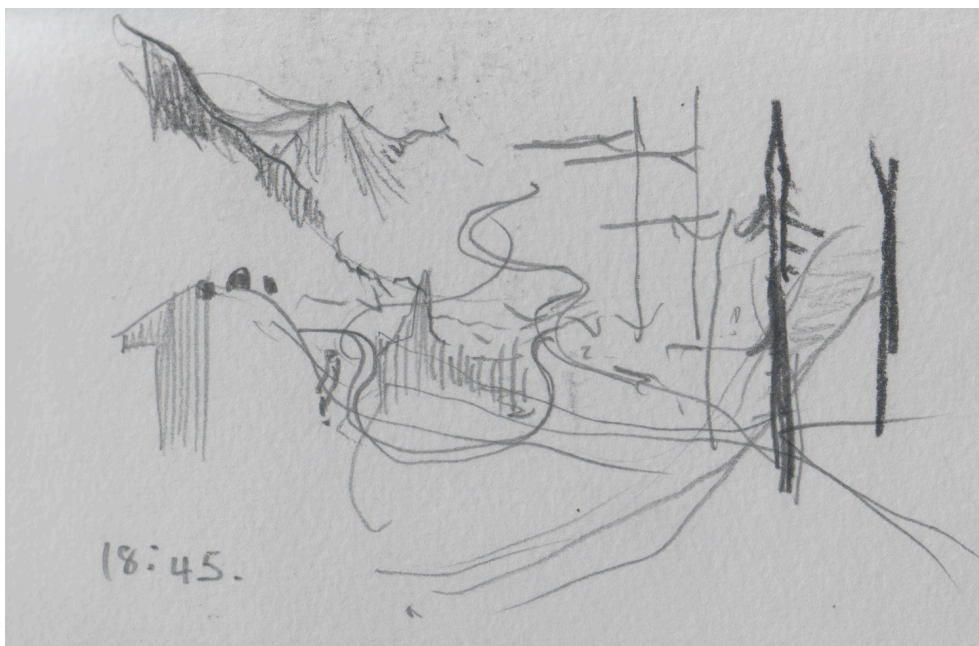
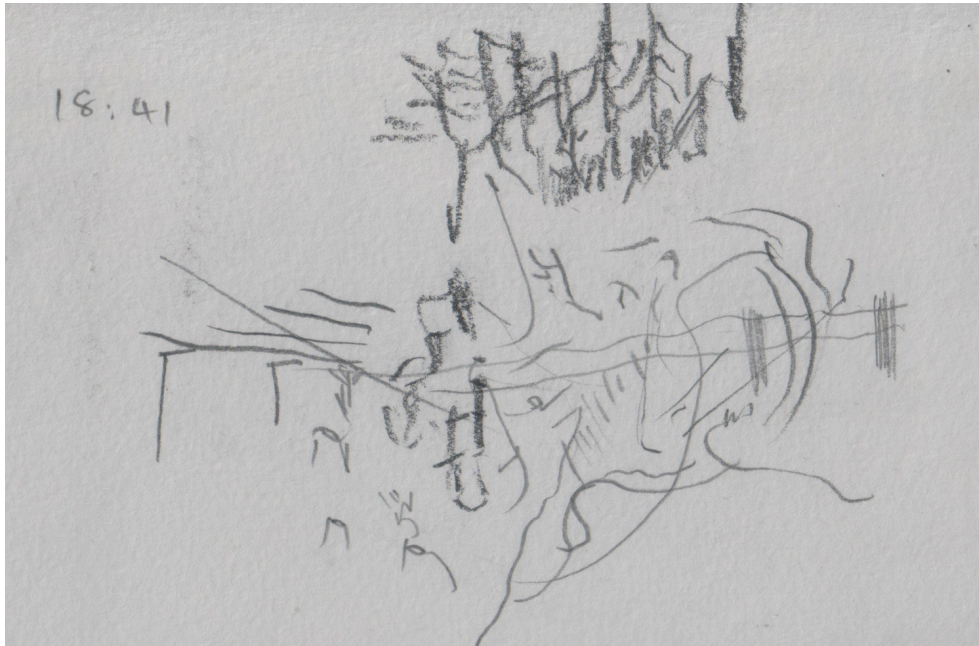

Fig. 3.16 (i-iv): Swiss Sketchbooks, pages from Guarda to Ardez, 2008.
Graphite on paper



This page and next:
Fig. 3.17 (i-iv): Swiss Sketchbooks, pages from Scuol to Diavolezza, 2008.
Graphite on paper





This page and next:
Fig. 3.18, (i-viii): Swiss Sketchbooks, pages from Diavolezza to Chur, 2008.
Graphite on paper

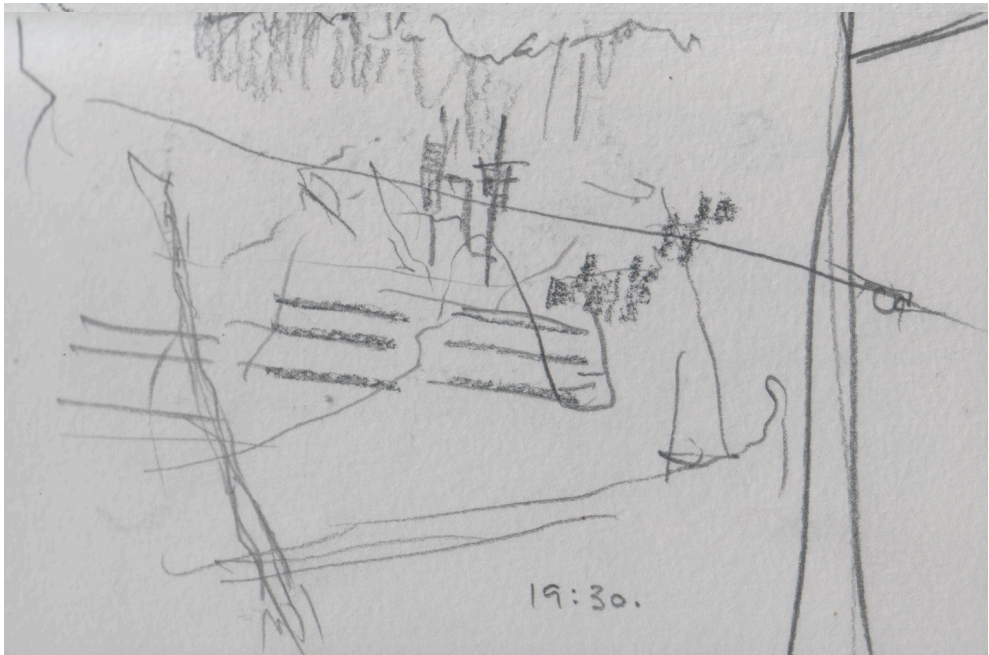

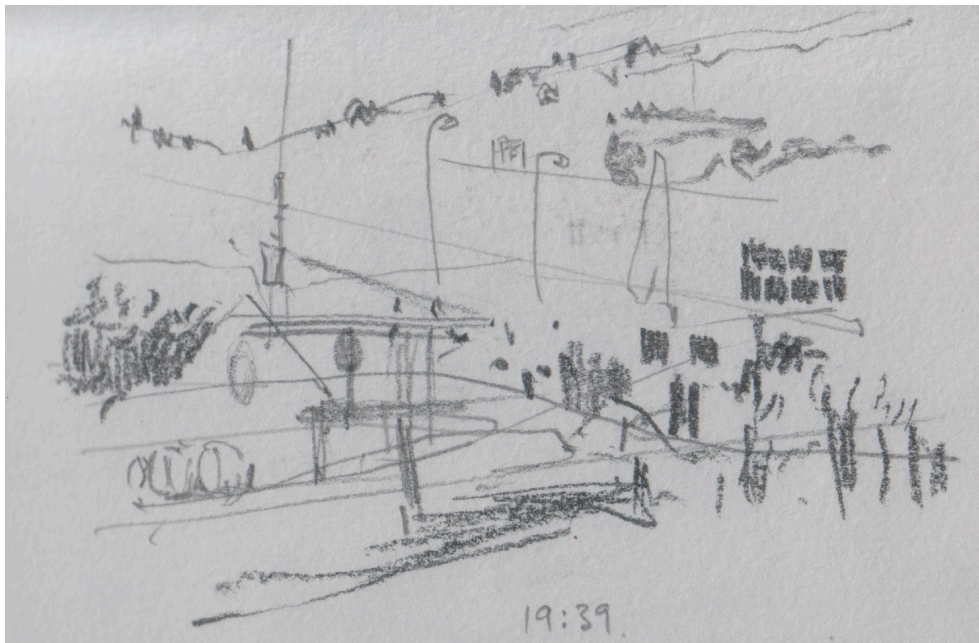
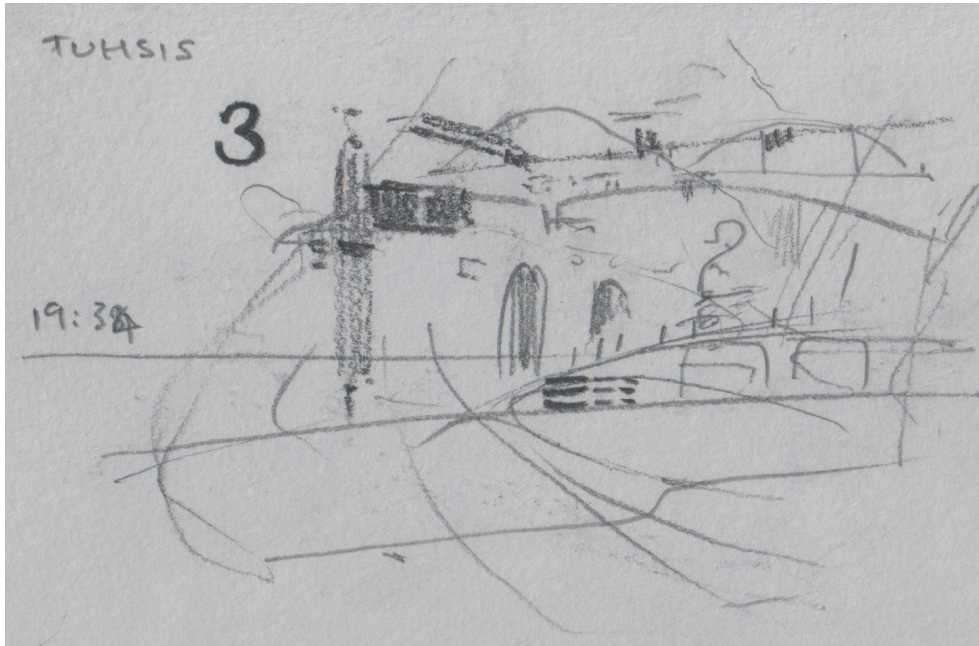

*Swiss Sketchbooks**Guarda to Ardez*

Having taken the train to Guarda in the west of Switzerland, we travelled three miles by foot to the town of Ardez. During the walk I made numerous sketches that picked out paths, signs, objects and small events such as a dead rodent covered in ants. Sporadically I recorded a GPS position before moving on. As the sketches continued I began to describe geographic features, vistas and directions of travel (fig. 3.16, i-iv). Looking back on the works many of the visual descriptions provide scant information on the topography, or the experience, of the walk - often becoming un-interpretable 'scribbles'. The speed, or time taken over each drawing also conditioned their rendering as 'readable' landscapes, appearing more notational in quickly produced sketches and more aesthetically considered in drawings that were made over a longer period of time. As one might expect, where images were created over a period of minutes rather than seconds not only did the kinds of marks change - so did the range of materials, and in particularly long periods of drawing - i.e. 5-10 minutes - colour was often employed.

Drawing whilst walking sometimes meant exactly that—attempting to make a sketch whilst the body was in movement. At other times it meant pausing and sketching whilst stationary. The size of the sketchbook, the lack of a physical support whilst making the drawings, and the act of controlling different weights and sizes of pencil, held between various fingers and alternated as required, meant a number of performative gestures needed to be accomplished in order to make a more acceptable or interesting drawing. As I began to develop a means of orchestrating the quick transition of media, or a more stable way of balancing the sketchbook I was able to think less about the orientation or arrangement of my own body and more about the acts and gestures of drawing. As these number of drawings increased I was able to make judgments about the kinds of physical gestures that would produce more visually *appealing* results.

Reflecting on the drawings produced during this excursion, there are recognisable shifts in the way the drawings are being conceived and actualised.

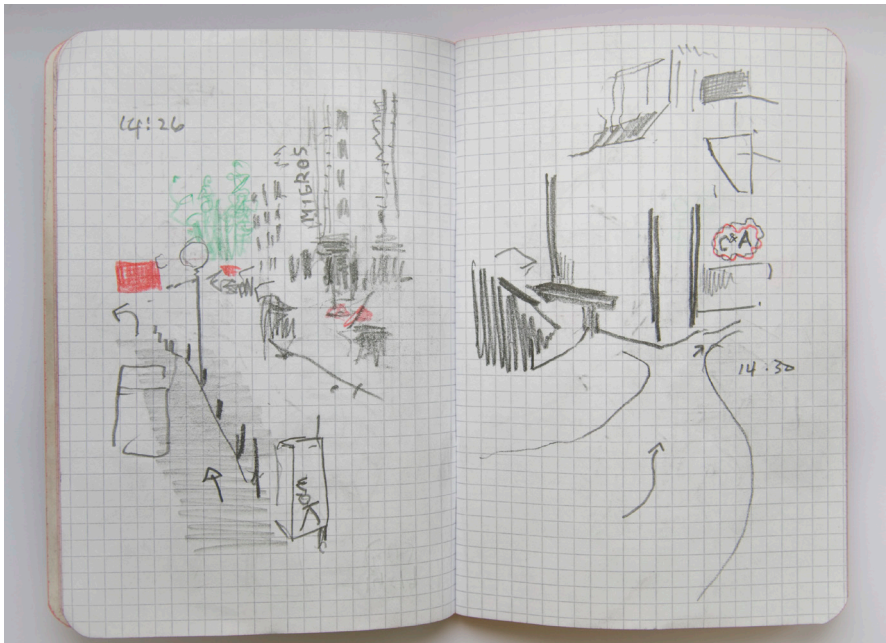

This page and next:
Fig. 3.19, (i-iv): Swiss Sketchbooks, pages from *LOST in Zürich*, 2008.
Graphite and coloured pencil on paper

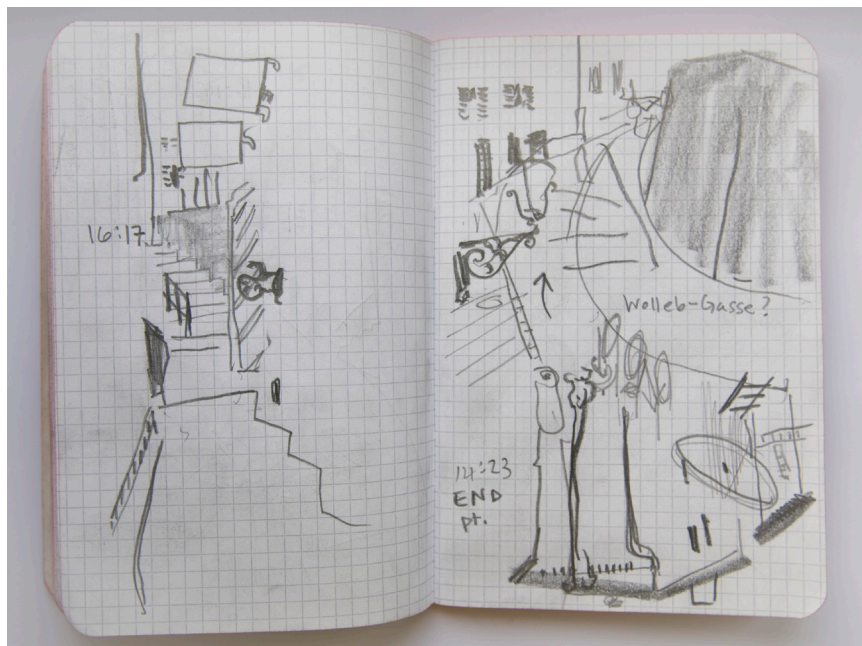
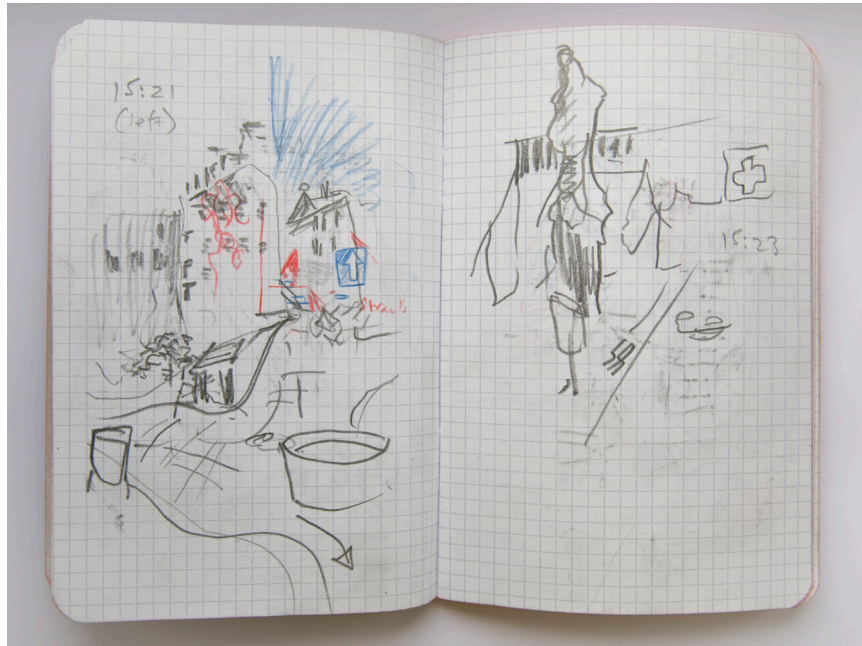

As with *LOST in Dorset*, these visual recordings often oscillated between direct annotation and more artful description, perhaps related to the gradual shifts in intention, with the sense that these were about notation giving way to a pleasure in the actions and movements of drawing itself. Within these sketches, and in those produced later on the journey to Piz Bernina (fig. 3.17, i-iv), there was also a sense of growing familiarity with the rhythms involved in their creation.

Many of the initial drawings are made using the same technique of 'continual line' drawing I had employed at the Russell Cotes museum, where the tip of the media does not, or rarely, leave the page. These progress into variations between continual line and using the 'side' of the media in order to create more textural marks, and to a form of continual line that involves twisting the media as you draw to produce variations in the flow of the mark. The sketches seemed to develop different emphases, take form in different ways as attempts to describe the environment by physically interpreting the twists of a path or stream might move towards a visually deconstruction and recomposing the shapes in a railway station, and discernible points emerged at which the drawing ceased to be concerned with describing an accurate record of what was being observed, and indulged in the act, the movement, the gesture of drawing itself. In one instance the flow described in the drawing of a curved mountain path is less a direct observation than a means of *feeling* a way through its apparent arc. The sensed movement, or flow of the arcing track as it cuts down the side of the mountain slope appeared to be physically complemented in the drawing by the friction and release offered by the pencil pushing through the surface of the paper.

Scuol to Diavolezza and Diavolezza to Chur

Two days later we took the Engadin Line train from Scuol to Pontresina and on to Bernina Diavolezza at the foot of the Diavolezza mountain. Another series of drawings followed, this time produced whilst travelling by train (fig. 3.18, i-viii). We ascended Diavolezza by cable car and at the top I continued to make drawings as we hiked up towards Munt Pers. Since the terrain was mostly rocky with steep drops down to the glacier the sketches seemed to

focus more on the flow of terrain and the tops of the mountain ranges (fig. 3.17, i-iv). Whilst I might have seen the purpose of the initial drawings as a means of visually narrating as directly as possible a sense of what I was seeing, I had been less thoughtful about how these marks came about. As with the sketches made two days previously on the walk between Guarda and Ardez, it appeared as if I had begun to think less of what was being drawn but how the drawing was made. Techniques developed through countless hours of observational drawing, both as a teacher and a student, had developed a certain kind of visual acuity, and I began to fall back into a number of well-practiced rhythms for drawing as I moved and drew through this environment. It would not, perhaps, be unreasonable to argue that the unfolding of an experience of *being* in the landscape was co-constituted with the gradual adaptation of a pre-acquired set of drawing skills and a bodily means of arranging materials in my hands and stabilising my position against the terrain. In physically pressing into and visually searching over the landscape, bodily movement, pad, pencils, shoes, rocks, flies and mountain haze constantly conditioned sets of relations to each other.

LOST in Zurich

The last series of drawing made in Switzerland were made as a direct response to *LOST in Dorset*. Here, those early questions about familiarity, distance and place still seemed to have some hold me. Perhaps still holding onto a belief that whilst the particular area might be strange to me when travelling in Dorset, the landscape was not. By revisiting these works in Switzerland there was a certain naivety in assuming that these acts would engender a sense of dislocation that could be mined for some pure experiential record of the processes of navigation and map-making. *LOST in Zurich* (fig. 3.19, i-iv) seemed to provide the possibility of an experience antithetical to those first meanderings in Dorset, principally that it was wandering in an unfamiliar urban environment.

Perhaps unsurprisingly, the works produced during this three-hour excursion bears similarities to those journeys mapped out earlier in the week as I fell into patterns of practice that I had now become comfortable with.

The use of certain kinds of mark (for example, sweeping, dotted, notational); and use of symbols to describe directions of travel, to record changes in transit (i.e. from foot to tram), or architecture, all seem to share strong visual resemblance as a means of pacing-thinking-drawing out the shifts and changes experienced in travelling through somewhere. And yet there was a definite sense that these drawings had moved away from that earlier *LOST* work produced in Dorset over a year before. The progression seemed to be defined by approaches to the act of drawing rather than outcome of what was being drawn. They had begun to shift away from a narrow idea of visual ‘data collection’ and towards a set of visualisations developed by ideas of draftsmanship.

So far I have highlighted a number of the shifts in the trajectory of the research: a number of to-ings and fro-ings between the map-like images being produced at various locations with various intentions, and a growing familiarity with debates in areas such as critical cartography and cultural geography. Shuttling-between evolving bodies of drawing and text I have outlined some of the practical and theoretical difficulties that began to demand more contingent understandings of mapping and drawing practices, and more fluid conceptions of space. I had set out with a distinctly phenomenological series of *sensory* experiments, central to which had been an interest in how I constructed experiential spatial schemas (Tuan, 2001, p.36) in my attempts to orientate myself in ‘unfamiliar’ locations. In doing so it became increasingly difficult to separate observing artist from observed environment, (see Wylie on Merleau-Ponty, 2007, p.147), but also the environment from the *doings* of practice. These shifts towards the performance of drawings, and towards a sense of practice as a fluid and volatile intersection of continuously occurring events, paralleled descriptions of space offered by a number of the theorists whose work was beginning to impact on the forming of the research, perhaps most notably that of Tim Ingold, Doreen Massey and Nigel Thrift.

After the exhibition of work for *Meeting Place*, and as I returned from the brief excursion to Switzerland, there was also a change in the way I would

make artworks. The next chapter, “Islands”, follows a return to a way of working in which there was no longer an curatorial imperative to direct towards a specific ‘site’ or location, but a requirement to cogitate on ideas of enclosure, a shift that would be accentuated as I moved from the Swiss Alps to the spare room of our rented house.

4. ISLANDS



Polyfilla, Paper and Pins

We can speak of an island mind. Those who live on an island, who grow to maturity there, have a view of the world that is spacious in an empty sense as the eye travels to an undisturbed horizon, a view that is particular, local, bounded and proud. Though to others the horizon of opportunity is no longer limited to the horizon visible from the shore (if it ever was), to the islander the limit of his island has been an emotional boundary. Among whatever else may condition their motives one psychological need arises from this view: the need to keep things encompassed; to continue to be able to walk or sail around the edges of a definite world; to know enough of its finite knowledge so that all that needs to be known can be known even if not known; to go to the center of the island and from there to sing or shout or reflect that however shattered it might seem to others, the island experience is, within itself, with all its conflicts, potentially whole. (Ritchie, 1977, p.188.)

I'm not entirely sure what it was that prompted me to pile a small amount of detritus, bits I had salvaged from the waste bin and the ashtray, onto a light box and photograph it. I had used the light box in the works produced for *Meeting Place* at the Russell-Cotes to aid in the tracing of outlines for some of the maps and, since the end of that show, it lay on the same table in the box room where it now served as a surface on which I put piles of drawings and texts. There were also images of islands, a *leitmotif* I had pursued in recent work, and other visual matter that I had collected (for whatever reason) during the various walks and gallery visits. There were cast-offs, cut-outs and scraps of material that must have had some now forgotten purpose. But perhaps the island image had been called to mind so often, through previous attempts to mentally circumscribe a location that might be 'discovered', that became almost habitual to refer back to it from time to time. From this one might infer that I suffered from the condition that historian John R. Gillis describes as 'islomania' (Gillis, 2010), a condition in which the affected is said to see islands in everything. If this were the case there would be some comfort in

Previous Page:

Fig. 4.1: Studio test shots for *Borderlands*, 2008.

knowing that this is an affliction that is ‘a central feature of Western culture’ (p.1).

Islands figure as archetypal images of origin, paradise and purgatory (Gillis, 2010; Baldacchino, 2007; Lowenthal, 2007), for renewal and isolation (Deleuze, 2004), for discovery and ecological fragility (Hennessy & McCleary, 2011). They have been conceived as microcosmic representations of the wider world (McMahon, 2010) and as unearthly forms that loom large on horizons (Gillis, 2007). Geographer Peter Hay goes as far as to make the case that the *metaphorical* island is ‘so enduring, all-pervading and commonplace’ that it might be considered ‘*the* central metaphor within western discourse.’ (Hay, 2006; p.26). But when the historian John Gillis notes that we not only think *about* islands, but *with* them (Gillis, 2010) he is also describing a proclivity within western thought to divide the world into neat and separated forms; to make islands of the things we experience as a means of understanding them. And for Gillis, the western imagination sees islands everywhere, ‘whether it be desert oases, or city ghettos, kitchen workspaces, highway dividers, groups of cells (the islets of Langerhans), parts of the brain (Island of Reil), and patterns found in fingerprints’ (ibid.; 1-2). There is no shortage of real islands in the world (Ronström, 2012), islands that are unique, diverse, although not always enticing, and yet it is those of the imaginative realm that seem to have the greatest hold (Tuan, 1990, p.118).

I trace my own interest back to the production of a number of artworks that attempted to represent the idyllic, and often took the form of physical and digital models, miniaturised holiday resorts or housing developments. The models were intended to offer up recreations that bore an uneasy relationship to their ‘real-world’ counterparts, often as essentialised reconstructions that acted as reminders of the uniformity of many cultural representations of ideal living. Although these early works were produced well before the research degree, at various stages of the making of new works there was a movement that reached back towards these past creations, a movement that the anthropologist Alfred Gell has described as a simultaneous retention and protention that seems to take up a perspective in relation to past artworks which both feeds and anticipates possible future creative events (Gell, 1998,

p.238). Certainly the island-image had figured in my response to *Meeting Place: Contemporary Art and the Museum Collection*, and as I began to discuss a new set of proposals for a new visual arts project it seemed to re-emerge as the conceptual hook, about which a number of questions around spatial representation turned. The exhibition *Borderlands* was intended to be an event that brought together parallel reflections on the idea of borders and hinterlands from two writers and two visual artists. I was jointly involved in the organisation of the exhibition, along with artist Tom Hall and curator Stephanie James. The other two contributors, Lee Mackinnon and Frank Brown, had been asked to produce written works for this exhibition. The show developed under several titles: *Island*, then briefly *Border Country*, before we settled on the title *Borderlands*. This titular shift is, perhaps, indicative of the attempts to frame the various spatial and artistic narratives of the contributors under one useful set of terms, but in doing so also provided grounds for thinking a set of relationships between the exhibition participants.

For my own part this interest in island was fed on divergent sources from Western historical accounts of Enlightenment exploration (and colonialism) in which islands were regarded, by those such as Louis-Antoine de Bougainville, as the last vestiges of a prelapsarian paradise (Withers, 1999), and in the elaborate and sometimes entirely fictionalised encounters of European 'discovery' such as Capt. J. A. Lawson's *Wanderings in the Interior of New Guinea* (1875). These explorations were, as geographer Doreen Massey (2005) puts it, voyages of discovery told in terms of 'crossing and conquering space', an 'expanse we travel across' (p.4). This image of space as an inhabitable expanse, as a surface of land and sea that enwraps the globe, enables a particular worldview, one that allows us to conceive other peoples and cultures as elements upon this surface, 'simply as phenomena' (ibid), rather than as belonging to complex shifting networks capable of producing of their own histories. And, at least through the Eighteenth and Nineteenth Centuries, perhaps some measure of credence in this image of the world was sustained by the 'new planetary consciousness of science' (Driver & Martins, 2005, p.9) whose vanguard of explorers, intellectuals and statesmen aimed 'to make the world an orderly place in the aim of enlightenment' (ibid). But as Massey is

wont to point out, these are conceptions that tame space into a geometric extent, a *vessel* for, and a means of ordering the temporal, still persist (2005, p.26).

By taking account of the practices that lay behind map making, the work of cartographers like Kitchin and Dodge had already altered a conceptualisation of mapping from the iconic and largely symbolic to something that was open-ended, contingent and relational. In the same vein, a return to the studio could no longer simply address intentions and outcomes as providing evidence of research activity, but also the interweavings, the movements and constellations of relation from in which these emerged—not as completed artefacts but as things-in-information, ‘the moment of formative force more than that of the formed work’ (Nancy, 2013, p.51). And yet, whilst these debates affected the approach to the process, they were not instituted as a method (for example Vannini and Taggart, 2013), but rather became sources of dialogue that moved ideas forward.

When I began the works that would end up in the exhibition *Borderlands*, the itinerant practices that had been central to a navigational narrative of spatial engagement, had now moved indoors. This seemed a long way from acting out a series of performative drawings in what Long has described as the ‘real spaces of the world’ (Wallis cited in Vaughan, 2009, p.319), or the ‘directly lived’ (McDonough, 1994; p.69) *dérive* inspired engagements. Yet, if the studio seemed to be a ‘retreat’ it was no less directly lived.

A return to the studio, or at least to the new spaces I negotiating for practical work at home, and burgeoning interest in non-representational theories began to direct my own way of thinking about making towards the *occurrent*, that is, towards the ‘event’ of practice, a turn that had arisen from certain growing apprehensions about the early phases of research experimentation. As practical and theoretical aspects of the study had started to divide, efforts to situate a number of positional relationships between artist-practitioner/artist-researcher and subject-matter/research-object had raised urgent questions about the structuring of the study, and the role I had assumed for myself. In these idealised early versions, the position of practitioner/researcher had been one of observer and interpreter within a system of

purposive situations that were constructed to reveal or describe something of place. The objects of research were both the artefactual outcomes of these situations: the drawings, performances, videos and sound recordings, etc., *and* the 'object' of place, (that is, an envisaging of place and/or space in terms of a research object). Now, the move towards a loosely defined studio environment directed a level of scrutiny on the situations from and in which the works now emerged. Yet it took a while to make sense of the dynamics of the studio, especially the urgency to complete the work for exhibition, even though at the same time conceiving the work in the research terms I had initially established, appeared to be pulling conception and production in opposite directions. The early influence of Massey's (2005) writings on space certainly set the grounds for a shift in thinking, since I largely expected the artwork to be expressing or elucidating something in largely representational terms. But whilst the works of other artists were ways of providing a useful context for my own creative activities, the analysis tended to be focussed on how these works offered different readings of spatial constructs, such as the map, the island, and now the studio. Massey's relational argument (1994; 2005) is a refusal to reduce our understanding of space to that of surface or container (2005, p.7; p.20). And she makes her case by extending three propositions:

First, that we recognise space as the product of interrelations; as constituted through interactions, from the immensity of the global to the intimately tiny... *Second*, that we understand space as the sphere of the possibility of existence of the multiplicity in the sense of contemporaneous plurality; as the sphere in which distinct trajectories co-exist; as the sphere therefore of coexisting heterogeneity... *Third*, that we recognise space as always under construction... it is never finished; never closed. Perhaps we could imagine space as a simultaneity of stories so far. (p.9)

As with many of the theorists in this study, Massey also draws on Deleuze-Guattarian philosophical influences in order to argue that a concept such as space, rather than operating as a de-temporalised essence, should 'express an event, a happening' (p.28).

In this case, the making of artistic work as a response to space was also informed by conceptions of space as a fluid, continual and open-ended experiencing of environment. If I were to think of space in this way, art practice needed to be reconsidered as spatial practice if, as the writer and critic Simon O’Sullivan describes it, art is also an event in continual resistance to closure: ‘Art then is the name of the object of an encounter, but also the name of the encounter itself, and indeed of that which is produced by the encounter’ (O’Sullivan, 2006, p.2). Thinking about practice in terms of event, therefore, was not simply the unfolding of a sequence of activities within a ‘privileged’ and territorialised space of the studio, since the concept of the studio itself needed to be rethought, or re-experienced, in terms of change. Again, where Massey talks about the representation of space—in my case the familiar space of the studio—she describes how we might see it as ‘no longer a process of fixing, but as an element in a continuous production; a part of itself, and itself constantly becoming’, and the activity, the practice, ‘an embedded engagement *in* the world of which it is a part’ (2005, p.28).

For me, turning attention towards the home-as-studio was less an act of artistic intention—a means of drawing attention to the invisible power geometries that existed between ‘home-life’ and ‘work-life’—than an issue of expediency. In fact I thought very little about appropriating part of a room for making work at home, I did not feel I was doing anything different than many other artists who work between different professional domains, in my case teaching and working as a practicing artist. Where it became imperative to consider this space was in thinking of the work I was able to produce, and the way I could produce it, in relation to how it influenced the practice *as* orientated towards an elucidation of a space/place relationships. Establishing a connection between artistic projects that were beginning to move in different directions led to more searching questions about the way I saw the research process.

Borderlands provided a framework for considering the porosity of spaces, the negotiations that might exist in attempting to define margins between things, and whilst *Meeting Place* had also been concerned with linear illustrations that referred to edges, these were largely founded on the visible and physical

extents of the museum architecture. Previously I had a location—a place to go to which promised the possibility of chance encounters, and as Massey puts it, ‘[o]n the one hand, that *is* one of the characteristics of space; that is the condition of both the existence of difference and the meeting up of the different’ (2005, p.179). The city, even in the convoluted and claustrophobic chambers of the Russell-Cotes Museum, leaches in. But perhaps I had not noticed.

Isolated Chambers, Mobile Sites

As a way of setting the scene for an increasingly dispersed conceptualisation of the studio, in the following section I look briefly at some of the ideas that have formed around this apparently private and privileged space, beginning in the years following the post-studio evictions of the late 1960’s and 1970’s. These brisk illustrations are not intended to form an inclusive review of the history of the artist’s studio, those narratives are already well described in numerous other texts, recently, for example, in Claire Doherty’s *From Studio to Situations* (2004), Brian O’Doherty’s *Studio and Cube* (2007), Walter Davidts and Kimberley Paice’s *The Fall of the Studio* (2009) and Mary Jane Jacob and Michelle Grabner’s *The Studio Reader* (2010). In the descriptions of the studio that follow, a number of writers challenge the island-like quality that artists like Robert Smithson once gave it when he declared that ‘[d]eliverance from the confines of the studio frees the artist to a degree from the snares of craft and the bondage of creativity.’ (Smithson cited in Harrison and Wood, 1993, p.867). I draw particularly on the work of art historians such as Morgan Thomas and Katve-Kaisa Kontturi and philosophers Brian Massumi and Erin Manning in order to open up a more dynamic and contingent idea of the studio, in which studio-ness is less an architectural confine than a succession of intensities, the product of multiple and continuous interrelations. By briefly examining a series of ideas that destabilise the notion of a fixed and private realm, I introduce a thread of thinking that continues through an increasingly post-representational analysis of the studio through the work of Kontturi. Here the sense of privacy and enclosure that is often used to conceptualise the

studio constantly escapes through the comings and goings of what Kontturi calls ‘collaborators’ (2012, p.89), or what Erin Manning and Brian Massumi describe as ‘intercessors’ (Manning and Massumi, 2014, p.64). For Kontturi, collaborators are human or non-human, fictive or real. Positioning her own observations alongside those of art historian Thalia Gouma-Peterson, whose work on artist Miriam Schapiro explores the idea of collaboration through Schapiro’s *femimages* (Gouma-Peterson, 1997, p.22), Kontturi moves to consider how impersonal connections between an individual artist and the works and individuals they identify with create more complex and ‘accurate’ images of the creative process (p.95). These propositions challenge the idea of the solo individual working alone in the studio, even when it might be claimed no other person has entered the space. As I have noted earlier, similar collaborative exchanges are identified by Manning and Massumi in their work with artist Bracha Ettinger and in the final part of this chapter I also turn briefly to their observations on her studio practice.

In much of the work I produced during this period the image of the island persisted, and it serves as a useful fulcrum around which the multiple trajectories of activities develop. A reminder, it seems, of the *idea* of enclosure and isolation, but one that is constantly breached and transgressed. But perhaps this also contrasts with the peripatetic practices that had emerged in the initial phases of the research. Practices that, despite being carried out in the public space of a municipal museum, remained tied to an idea of artistic production as a highly individual activity.

When Richard Long juxtaposed a photograph of himself climbing Mt. Kilimanjaro alongside one of the Long Man of Wilmington in the catalogue for *The New Art* exhibition it was a representation that supported the idea of the itinerant artist as an outdoorsman, a solitary individual (Wood, 1999, p.75). Whilst Long’s work adopted the quotidian practice of walking as a form of dematerialised alternative to object-orientated artworld of the late 1960’s and early 1970’s, (Wood, 1999, p.66; Kwon, 2004, p.24; Sleeman, 2012, p.72) nevertheless it engaged with the construction, and dissemination of a particular kind of mythological narrative:

The catalogue of 1971's *The British Avant Garde* included a full-page colour image of Long pictured on a rolling, verdant moor, dressed in hiking gear and unshaven beside a neatly tacked-down tent. As the caption—'Richard Long standing near his walk'—makes clear, this is not a specific work Long executed, or an image of him working. He is 'standing near' his walk, resting for a moment in perfect character to personify his pastoral work ... Long as a solitary individual incarnating past habits, working on variations on circles and lines. Enacting walks of severe discipline, he composed arrangements unidentifiable as art without a pictorial souvenir substituting for the remote, all but unlocatable, makeshift effort imaged through photography. Not depicted is the artist sorting negatives and contact sheets, ordering prints or travelling to talk to dealers and collectors. These are historic roles unrelated to the folk memories and inviolable self-image that served as a phantom projection of the figure Long had become. (Wood, 1999, p.75.)

At around the same time in Canada, artist Ian Wallace made precisely this turn towards the interior of his own studio, not simply as a documentation of his workspace, but as an integral part of the production of final works:

When I began to make photographic documentation of my workspace in the late 1960's, I came to realise that this documentation could be considered as a part of the work process, even as a finished work in itself. It also became apparent that the space or place of production, the studio as an actual as well as a symbolic environment, would be a necessary element in the imagery of this process, as the actual mise-en-scène for the materialization of the conceptual, non-objective nature of art. (Wallace, 2012, p.170)

As Wallace acknowledges, artists have often taken photographs of their own studios, and during the mid-twentieth century an entire genre of documentary photography grew from the work of photographers such as Arnold Newman and Hans Namuth, who recorded images of artists like Jackson Pollock and Alexander Calder in their studio environment. But Wallace's aim was to bring some tension between the 'ground' and the 'figure' by incorporating both the painted canvas and the images of the studio in one finished work.

The ‘topography’ of the photographic space can thus assume greater complexity if studied in detail. The tools of production (ladder, tables, stretcher bars, canvas, ruler and tape, canvas pliers and stapler, etc.) stand out in the image as figurative emblems that refer to a particular stage in the production process; that is, in the preparation of the canvas ground only, for neither the photographic nor the painting process in itself are represented. There is an emphasis on the ‘ground’ then, that draws attention to the problematic of ‘figure-ground’ relations that are central to this series and all works on canvas related to it. (Wallace, 2012, p.175)

In his analysis of this series of images, *Corner of the Studio and El Taller: A Reflection on Two Works from 1993/2005*, (2012), Wallace is also intent on bridging ‘the gap between the sensory and the intellectual’ (p.170), and he demonstrates this by drawing our attention to the changes of use the studio undergoes. He sees *Corner of the Studio* (1993) (fig. 4.2), as representing a ‘space for thinking’, whereas *El Taller* (1993) (fig. 4.3), becomes representative of a ‘working space’ (2012, p.172). Yet, as he explains, the act of photographing *Corner of the Studio* involved the interruption of an act of reading (Stéphane Mallarmé’s *Un Coup de Dés* rests on the table in the image), and so reading is displaced by the activity of taking light meter readings, adjusting the camera, and so on. As Wallace turns towards the question of space we are asked to consider it in relation to the internal dynamics and compositional structure of the pictorial plane. The image provides the ‘visual interplay between flat, closed space and open, recessive space, such as can be seen in the perspective in the tilt of the plane of the floor; a distant view through an open window, the flatness of a canvas leaning against a wall’, (p.178). Indeed it is in the optical relation between image and surface that he sees space as being ‘carved out’, and simultaneously he describes this as a means of trapping the eye in ‘the logic of virtual space, the mirror simulation of actual space that is inherent to photography’, (ibid.).

One might reasonably ask, then, if the studio, in these images, is also a cipher for a particular idea of creative space. If the dynamics of this representation exist in the formal interplay between the blocks of printed surface matter and the photographs of studio interiors, could one not



Fig. 4.2, (above): Ian Wallace *Corner of the Studio I-IV*, 1993.

Ink monoprint with photolaminate and acrylic on canvas.

Fig. 4.3 (below): Ian Wallace, *El Taller*, 1993

Photolaminate, acrylic and monoprint on canvas (198 x 122 cm).

All images reproduced with kind permission of the artist.

substitute any other kind of architecturally similar interior and achieve a visually similar experience? As Wallace himself suggests, the idea of *Studio Series* (1969-) in which these images belong, is both an attempt to build a bridge between the sensory and the intellectual space that the studio seems to represent, but also as a means for *self*-reflection (p.171), that imagines the private space of production in relation to the ‘objective or social space of ... the “museum” and the “street”’ (ibid.), but it is also a representation in which the studio is not simply the enclosed and private environment for single-minded activities. It appears to tend towards the museum or gallery as much as the self-contained space of intense contemplation, implying that the museum or gallery is *also* in the studio.

Whilst the Western idea of the professional studio emerged in the Renaissance (Bellony-Rewald & Peppiatt, 1983, p.3; Waterfield, 2009, p.1), in art schools the emergence of the private studio space appears to coincide, somewhat ironically, with the self-imposed post-studio evictions of the late 1960’s and early 1970’s. In his essay *A Possible Contradiction* (2010), Howard Singerman describes this as a development of the more general working spaces that were provided by the school under disciplinary métiers, such as the painting or the printmaking studio (Singerman, 2010, p.40). By drawing on an account of the contemporary art school studio in 1971, Singerman observes that:

In a nice twist... the nearly obligatory private studio arrives at the same moment as the term post-studio. That label was probably first used in 1972 by Lawrence Alloway, who characterized Robert Smithson’s practice as “a ‘post-studio’ system of operation,” but by the end of the decade it had come to name the broadly influential program headed by John Baldessari, Douglas Huebler and Michael Asher at the California Institute of Arts, a program that continued to offer its students individual studios—perhaps because the studio it sought to put into question, or to surpass, was not so much the private one as the general one, and a certain conjunction of space, artistic identity, and “studio” practice. (Singerman, 2010, p.40-41)

Singerman’s interest is in the apparent contradiction that accompanies much

of the rhetoric around the studio, the idea that the individual studio functions both as isolated, private and idiosyncratic space, and as a social, networking and negotiating space. Through a description provided by the painter Patrick Heron, and through Daniel Buren's post-studio critique, Singerman sees the myth of the isolated individual as first confined to a room that is created as an echo to her or his idiosyncratic characteristics, then tied to the work of art as 'the emblem of artistic autonomy' (Singerman, 2010, p.41).

For Buren, this primary frame in which the art work is constituted, and which precedes the (cultural) frame of the museum, gallery art history, economics, is the frame that isolates and protects the work of art from the outside world. The studio is: 'the place where the work originates... generally a private place, an ivory tower perhaps... a stationary place where portable objects are produced.' (Buren, 1988, p.201). But, as writer and curator Wouter Davidts notes, Buren's distrust of the studio does not rest entirely on a radical critique of the production and consumption of art (Davidts, 2009, p.70). Davidts points to the conclusion of Buren's argument in which he describes one personal and one historical example of the 'idealizing and ossifying function' of the studio (Buren, 1988, p.55). Both of these examples suggest a more nostalgic sense of separation between work(s) and their situation of creation, or as Davidts observes:

...what bothers Buren the most is that, when artworks move to the museum, they are severed from all other works, objects, and traces that mark and populate the working space and which are a part of the production process. Buren is thus not so much preoccupied by the production process itself, but first and foremost by the environment of the workplace. He does not want to renounce the genuine presence of an artwork amidst its production context — which, according to the artist, is "extinguished by the museum's desire to 'install'". In fact further on it becomes apparent that he even wants to regain a certain authentic presentness... when he discusses another... influence for his suspicion: the studio of Constantin Brancusi. (Davidts, 2009, p.73)

Brancusi's will provided the French State with the contents of his studio under the condition that it remained preserved together, and in doing so

“short-circuit[ed] the museum’s desire to classify, to embellish, and to select” (Buren, 1988, p.57-58). Elsewhere Davidts and Paice (2009, p.8) also remark on the emphasis placed not on the extinction, but on the *transformation*, of the studio by Lucy Lippard and John Chandler in their influential essay *The Dematerialisation of Art* (1968). Whilst the term post-studio may not have been coined at this point (Davidts & Paice, 2009, p.7; Singerman, 2010, p.40), the radical reassessment of the institutional structures that surrounded art making was well underway. Lippard and Chandler’s assessment of the transformation *returns* the idea of the studio as a space for intellectual thought rather than as a workshop for material labour (Davidts & Paice, 2009, p.8). In doing so it echoes the historical construct of the ‘studiolo’ in Renaissance Italy, a term which differentiated the ‘bottega’, or workshop from the private and scholarly rooms of the learned artist (Waterfield, 2009, p.1). Patrick Heron’s description of the art students’ studio, in which an individual ‘creates the space he needs in the style he needs it’ (Heron cited in Singerman, 2010, p.40), and over time forge their identity so closely with this space that their ‘cubicles or alcoves have the highly developed personal and idiosyncratic character of a private dwelling’ (ibid), implies an isomorphism between culture and space that seems to further an idea of the bounded ‘place’ of the studio and firmly inscribe it as the solitary and exclusive domain of the artist, although for many women artists, such as Miriam Schapiro, the delineation between what is described as the artists professional space and the real idiosyncrasies of working in a ‘private dwelling’ were often made sharply apparent (c.f Gouma-Peterson, 1997, p.11). The critic Morgan Thomas sees this desire to link the ‘closed world’ of the studio to that of the artists’ character, (and subsequently to their work), as tied to a representational impulse to frame the Modernist studio in terms of the valorisation of isolation, and to mark out a distinct rupture between Modern and Postmodern ways of thinking.

The hypothesis of the post-studio era... depends on at least three interconnected formulations of framings. First, the studio is taken to be—is framed as—a frame, a division of inside from outside, an enclosure. Second, the studio thus understood, is taken to be metonymic of the historical situation of Modernism, and Modernist

painting and sculpture in particular. Third (a periodizing frame), there is the supposition that the studio and the forms of modern art with which it is allied, are in a decisive sense finished, historical. (Thomas, 2009, p.24)

For Thomas, Rothko's studio and his suicide are bound into a familiar narration of Modernism in which the private confrontation between artist and work is bounded by the quasi-psychological space of this isolated and idiosyncratic realm (cf. Elkins, 1999; Chare, 2009). It is a mythology supported by the reconstruction and restoration of the working 'chambers' of Modernist artists. Francis Bacon's Reece Mews Studio, Jackson Pollock and Lee Krastner's house and studio, and Barbara Hepworth's Trewyn Studio, (now the Barbara Hepworth Museum and Sculpture Garden) all physically attest to the venerated spaces of Modernism, and to the boundaries these once drew between the artist and the outside world.

But Thomas seems to suggest it is a mythology that is also supported by the need to define a pivotal historical moment, one that separates, in one defining rupture, different cultural paradigms (p.26). She sees this in the descriptions of Rothko's works and the circumstances of his death provided by the philosopher Slavoj Žižek in his book *Looking Awry* (1991). Žižek's account argues that the dark zones or black squares of Rothko's 1960's paintings are paranoid constructions that attempt to diminish the threat of the real by giving it definite shape. For Žižek, it is Rothko's inability to contain the real, evidenced in the growing scale of his later paintings, that anticipates his later suicide. As Thomas illustrates it:

Žižek summons the image of Rothko's suicide in his studio in 1970 — he was “one day found dead in his New York loft, in a pool of blood” — as only a further, final, confirming instance of the struggle motivating the work. The loft-studio is in effect positioned as yet another modernist black square, yet another attempt to exclude the real that doesn't work. (Thomas, 2009, p.25)

The narrative of heroic failure by which the Modernist studio is mythologised as sanctuary and sanatorium excludes this space from the reality of the world

outside. The Modernist studio becomes neither a social space nor a 'real' space, but one that is increasingly seen as a looped narrative, in which artist-myth and studio-myth are co-mingled:

The space in which the artist thinks is thus a thinking space, a double enclosure, reciprocal, self-referential, compressed, the round skull in the studio box. This doubleness enhances the rhetoric of both the artist and the studio in a shimmer of signs and synecdoches: the studio stands for the art, the artist's implements for the artist, the artist for the process, the product for the artist, the artist for the studio. (O'Docherty, 2007, p.6.)

Certainly it seems that Rothko's studio conjures this mythopoetic image more than most late modernist artists, but Thomas also draws attention to one historical observation. Rothko rented his first studio in 1952, at the age of 48. Prior to this Rothko painted in the living room of his house. He also moved studios with relatively frequency, in 1956, 1958, 1962 and finally



Fig. 4.4: Alexander Liberman *Mark Rothko*, 1964.
Gelatin silver print
© The J. Paul Getty Trust.

to the East 69th Studio in 1965. Thomas sees these moves as significant as they appear to tie in with commissions at given locations: in ‘1965, with the Chapel commission, in 1962 with his commission to paint for the Holyoke Centre at Harvard University, and in 1958 with the commission for the Four Seasons restaurant in the Seagram Building in New York.’ (Thomas, 2009, p.35) She also sees these changes in location as important because in each case the studios appear to have been chosen for their scale and their relation to the location of their final exhibition.

For the Chapel project, Rothko had to find a studio that was large enough for the work. A built-to-scale simulation of three of the eight walls of the chapel, still to be built in Houston, came next. The Seagram and Harvard projects involved similar sequences. The studio set-up comes after — is an effect of — the determination of the work’s projected destination. (Thomas, 2009, p.35)

If we accept Thomas’s argument we might draw out an idea of Rothko’s studio not as the mirror of his psyche but as a re-production—a space whose dimensions are tending towards or echoing back another site, that of the works eventual display. Described this way Rothko’s studio is no longer a fixed and isolated chamber, untethered from the ‘world outdoors’, but is instead very much a space that is defined in relation to other spaces. In arranging this space in such a way that the studio moves towards the site; it becomes ‘site-orientated’, it does not mimic (there is no suggestion that this was an attempt to faithfully replicate the eventual installation space), but provides the conditions necessary for an exchange, a connection, between the two.

The reconstructions of the studios of deceased artists, (such as Bacon’s Reece Mews studio), seem designed to direct us towards an image of the studio as a timelessness place, one whose ‘essence’ is caught in a kind of reflective moment, as if the artist has just abandoned some furious creative activity and temporarily left. In these emptied chambers it seems that every effort has been made to persuade us that these are the immobile and interior worlds of a peculiar kind people: thinkers, artists, visionaries. Even, perhaps, when we know they have been meticulously reconstructed over 300 miles

from their original location. It is precisely this timeless, banal, authenticity that Buren directs us to in Brancusi's final behest. What Buren sees as a defiant retort to the museum curators' desire to select, sever, classify and embellish the art object outside the work-a-day environment of the studio, can also be seen as prescient of the strategies of the heritage industry, that (often) act to protect and preserve the 'authenticity' of culturally significant places. Buren sees the retention of works 'amidst the clutter of the studio—various tools; other works' (Buren, 1988, p.207) as offering an alternative to the sterilised ideas of beauty or purity contained in the immaculate spaces of the museum. Thus not only does Brancusi posthumously refuse the 'speculative ventures' of gallerists and museum owners, he 'afford[s] the visitor the same perspective as [Brancusi] at the moment of creation' (p.206). This retention of an artists perspective on the 'moment of creation' had to be revisited by Buren in a footnote that accompanied its republishing in *October* magazine in 1979, by which time Brancusi's studio had been reconstructed first in the original Museum of Modern Art, Paris (now the Palais de Tokyo), and again in a building designed to replicate Brancusi's original studio adjacent to the Centre Georges Pompidou (Buren uses its previous title Centre Beaubourg). Despite Buren's desire to see this posthumous act as a means of escaping the classifying grasp of the museum curator, the museum, it appears, simply accommodates the entire space itself, and gradually reduces it to the sterile, well-lit simulation in which it is currently housed. In a good deal of post-studio discourse the role of the studio has been reduced to one of insularity, singularity and atemporality. Described as a stationary place, the studio and the products that issue from it are often seen as increasingly divorced from the rest of the world. Even beyond the inhabitation of the artist, the mythology of the space as a contained and private entity appears to hold a firm grip on the imagination. And yet none of these descriptions quite contain the 'studio' as a place of stasis; as a fixed and timeless realm or as a space with a discrete and private purpose. Even in their reconstruction, the studio (even as a representation) is a space in flux, in the process of becoming something else.



Fig. 4.5: Renzo Piano Building Workshop *Reconstruction of the Atelier Brancusi*, 1992-97.
© Michel Denanc

Studio Movements

I now return to the activities that took place in my own studio space in preparation for the *Borderlands* exhibition, in order to reflect on this idea of the studio as a dynamic environment that is resistant to closure, by considering my own studio experiences alongside recent work by art historian Katve-Kaisa Kontturi, whose thesis, *Following the Flows of Process: A New Materialist Account of Contemporary Art* (2012) offers a process-orientated analysis of the arts practices of three artists working in Turku, Finland. Kontturi's approach to an examination of creative process and exhibition, not only draws on similar philosophical strands that follow processual and materially orientated understandings of experience, but also explores similar studio-based territories—in particular her work with artist Susana Nevado¹. This particular part of her study might be said to focus on what Harriet Hawkins describes as the 'micro-geographies of artistic practices: the materialised "doings," the embodied practices and sayings and unsaid elements of the creative process' that make up the complex spatial idea of the studio (Hawkins, 2014, p.92). As an art historian, Kontturi approaches her analysis not by looking at ways of reading the objects that come from art production, but by 'following' in the production process itself. As Kontturi describes it:

As a way of approaching, following indicates movement; two-way, multi-way movement. The follower does not and cannot stay still, she must continuously adjust, attune herself to the movements of that which is followed. In other words, the follower is affected by the followee, and not only the other way around. This makes following a fundamentally relational process: a way of *participating* in a process. (Kontturi, 2012, p.14)

Kontturi's work is also influenced by the process-relational philosophy of Deleuze and Guattari, and also what have been described as the 'new materialist' philosophies of writers like Elizabeth Grosz and Barbara Bolt. Her emphasis is less on what artworks might be said to represent, than

¹ An edited version of this work appeared as the text *From Double Navel to Particle-Sign* in Barrett and Bolt's *Carnal Knowledge: Towards a 'New Materialism' Through the Arts* (2013)

on what they *do*; how they connect and transform. This focus on what Kontturi describes as the ‘flows’ of artistic process is not limited simply to the movements and performances of the individual artist as they carry out their practical work in the studio, but on the unpredictable encounters and assemblages that co-produce subjectivities, objectivities and environments. An outline of this comes in her initial description of visiting the studio of artist Susana Nevado, in which she attempts to look beyond representational explanations of religious iconography, and ‘pin-up’ girl images that litter the studio, in order to explore the reactions and transformations of materials themselves:

I engaged in a material movement of different sorts: a painting emerging through the layers of paint, varnish, lace and paper scraps that reacted and transformed each other—made each other. Whilst this movement included representational materials, such as pin up figures and poses derived from religious imagery, in the end, these did not appear as separate signs inscribed on the canvas, but were themselves active matters among other matters making the work. The same complexity holds true for the artist’s role in the emergence: Nevado surely had her hands in the process and some tentative intentions even, but these did not rule the project. What emerged was a surprise for the artist too. (Kontturi, 2012, p.41)

Kontturi’s experiences are useful here because they take forward an understanding of artistic spaces and practices beyond the idea of an individual, her ideas, her materials and an (enclosing) environment. And her work is interesting because it seeks to work alongside the artists, and to establish a proximity between historian and artist: ‘new materialist knowledge and conceptions do not arise from theoretical discussions only, or from the fixed point of view of the researcher alone; it is *with art* that theory-making happens’ (p.15). But Kontturi also draws attention to the collaborative experiences of a working studio by pointing not only to those human collaborators who may sometimes occupy the same space or with whom the artists shares a discourse, and not only to the material agency of the work itself—that is, the capacity of the emerging art-form to act on the artist. She also describes an

impersonal connective ‘collaboration’ that exist in the references to artists and artworks that might be seen pinned to the wall or on open book pages, and Kontturi does this by examining the idea of collaboration through the femmages of artist Miriam Schapiro, and the writings of art historian Thalia Gouma-Peterson.

Her visits to Nevado’s studio suggest a similar resistance to the representation of the artist’s studio as a mysterious, private and impenetrable world that Morgan Thomas has also advanced (2009), but Kontturi moves in a direction that incorporates the *matter* of art production and the ‘reciprocity and movement of bodies involved in art processes, that is, between the human and the non-human bodies of art’ (Kontturi, p.42). In Kontturi’s analysis, it is a *molecular* conceptualisation of artistic encountering that emphasises the movement between things and subjects, and that takes account of the ‘volatility and fluidity’ (p.192) of creative processes. Molecularity, which emerges in Deleuze and Guattari’s work, but which Kontturi also follows through the art-orientated writings of Barbara Bolt and Simon O’Sullivan, appears to form the cornerstone of her thesis (p.191). As a concept, molecularity signals continuous movement and exchange, a porosity between seemingly neat boundaries. She explains that:

Concisely put ... the seemingly rigid borders of things and subjects are continuously traversed and pierced by molecular flows: nothing remains solid, independent, immobile. Molecularity, then, designates a persistent differential movement of the world; and crucially a movement that is not teleological but creative and open-ended. (Kontturi, 2012, p.42)

Yet molecularity does not preclude form or mass; in Deleuze and Guattari’s terms the molecular flows or flees the binary organisations—the ‘molar aggregates’—that stratify or classify distinctions such as body, class, gender, East or West (Deleuze & Guattari, 1987, p.216). My understanding of this is that the molar sets out the outline, the periphery, the ‘wholeness’ of things, whilst the molecular constantly transgresses, moves between, anticipates its change. For the spaces of artistic production, molecular processes draw

attention to the vitality of matter and the mutability of structures such as the studio or the gallery. Bolt's description of the oscillation between molar and molecular in terms of drawing and exhibiting provides a continuum of forming and deforming moments between the acts of marking and the acts of viewing:

Endowed with organs and functions, "I" am defined by my form. My form distinguishes me as a molar entity. A piece of charcoal, a pencil, a rubber, a can of fixative and sheet of paper are also molar entities. However, when these entities enter into composition with a landscape, a model or whatever, they transform and move towards the molecular. Charcoal, body, rubber and paper enter an intense state, a state of varying movements and speed, hesitation, slowness and rest. My hand becomes charcoal marking the paper. Charcoal and speed and landscape become with the paper. The paper enters into composition with a frame and the picture-frame enters into composition within the gallery. The picture-frame-gallery enters into composition again and again in different ways and at different speeds with each viewer ... There are moments when the work coalesces into a molarity such as in an interpretive moment. But even in the interpretive act, another flow escapes the frame ... In the process the picture has fled the regime of representation. (Bolt, 2004, p.45)

In Nevado's studio these moments of coalescence and dispersal are described in oscillation around attempts at meaning-making and *un*-making, which, for Kontturi, appear to test the question of artistic mastery. Nevado aims to bring together Catholic imagery (specifically iconography of the Maria Madre de la Misericordia, or the Mother of Mercy), with photographs of her female friends modelling in their underwear. Nevado's initial intention seems to be to connect, in the mind of the viewer, the idealised ways in which women are represented, and Catholic attitudes to the female body, alongside '[a]n amount of "real" flesh and blood' (Kontturi, 2012, p.66), provided by the photographs of her friends. These appear to echo, in many cases, the outstretched gestures of the Maria Madre de la Misericordia. But in the visits Kontturi makes to Nevado's studio she notes the difficulties she faces when the work appears to become 'too self-evident—that is, too identifiable',

(p.68). It is an observation that seems to point towards the sedimentation of imagery within a too consistent or coherent frame. But as things seem to move towards an apparent state of fixity, new molecular movements seem to work against this coalescence: ‘the painting was too stiff... This was why she introduced the magazines into the painting: in order to move the painting, to get something to happen’ (p.68). Kontturi notes that whilst it was Nevado’s hands doing the moving, she was not in charge of the process—she did not know where the painting was going anymore. And yet she is also at pains to counter the idea that Nevado’s experiences of not-knowing might be a return to the same transcendental ideals of romanticism or modernism; indeed Kontturi’s observations follow a line of radical empirical philosophy that is rooted in an understanding of experience as *immanent* (p.32), and as such, Nevado’s actions do not escape the processuality of the world.

In Kontturi’s descriptions of the repeated visits to Nevado’s studio between 2003 and 2005, she provides us with a narrative in which the artist is seen not as ‘master’ of the processes, but perhaps more as a collaborator. Indeed Kontturi hopes that by drawing our attention to the material entanglements of Nevado’s processes we might venture ‘beyond the logic of clear intention and the simple mechanics of doing’, by directing us to consider the agency of the material processes themselves, and she reminds us, ‘it was the scraps that Nevado introduced to the painting to get something to happen’ (Kontturi, 2012, p.70). In a similar vein, Bolt’s articulations of her own practice set out not only with the proposition that art is a performative, and not simply a representational process, but that it is co-productive; that ‘through creative practice, a dynamic material exchange can occur between objects, bodies and images’ (p.8).

In the room I now refer to as the studio, the first photographic images that are created make no attempt to offer the convincing illusion of an island, although the idea of an island is somewhere in my own mind. A roll of drafting paper provides a simple backdrop, and with the light table illuminated the ‘island’ casts a shadow on what might be described as the ‘sky’. There is a sense of prehension, a sense that these actions are moving towards, or grasping at a

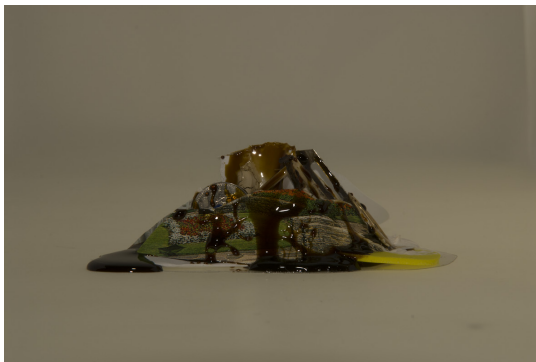
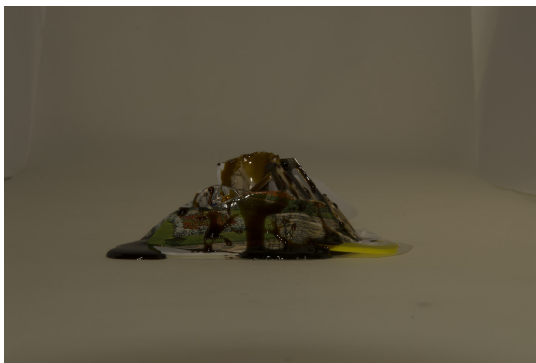

Fig. 4.6: Studio test shots for *45°S*, 2008.

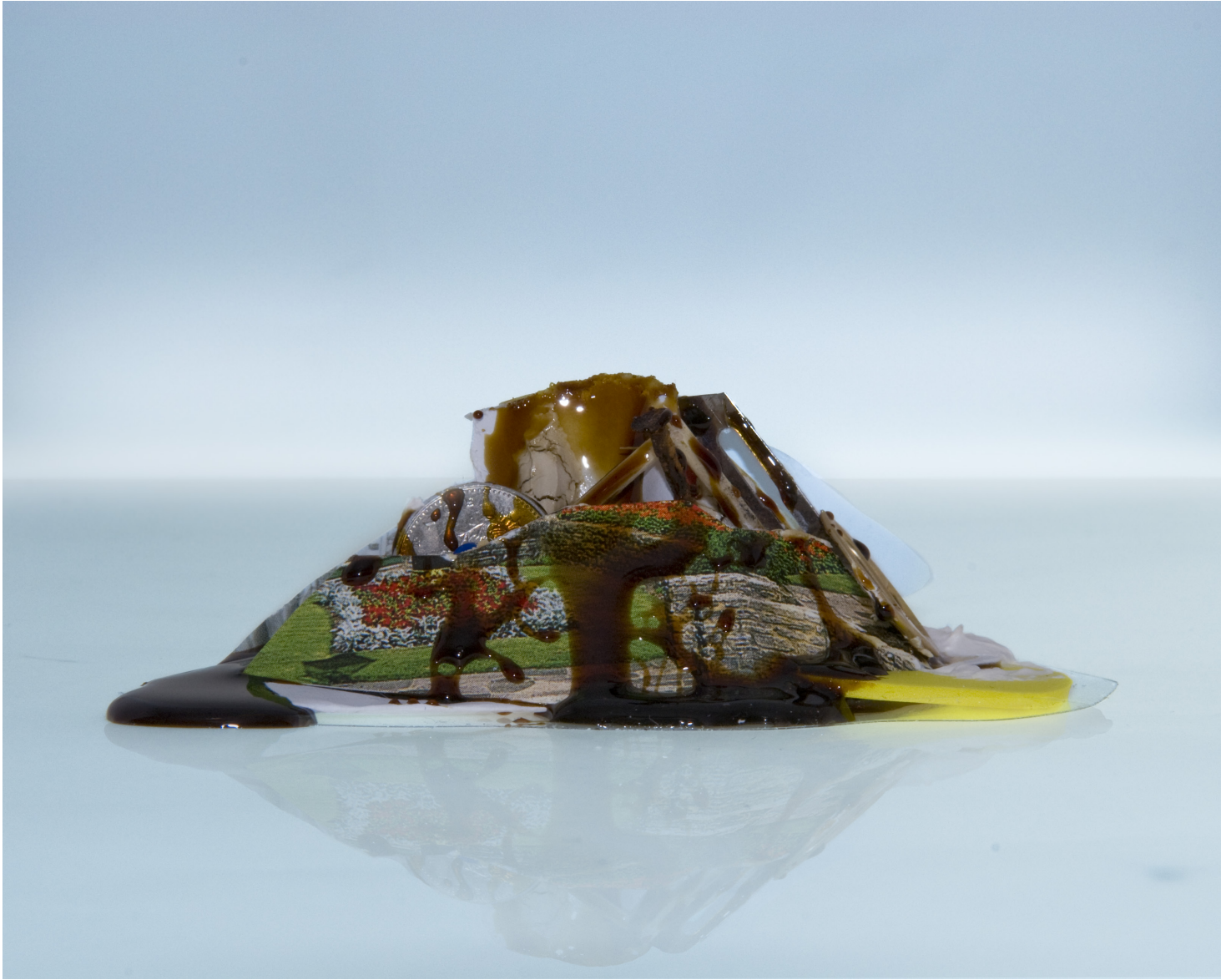

Fig. 4.7: *45°S*, 2008.
Inkjet on archival paper

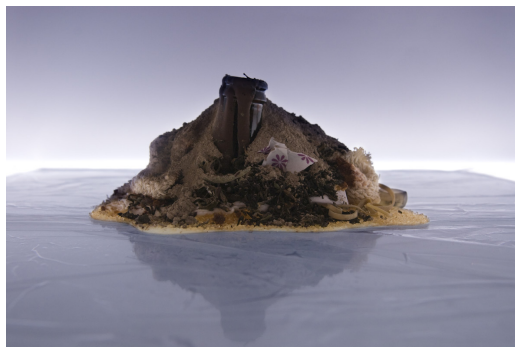
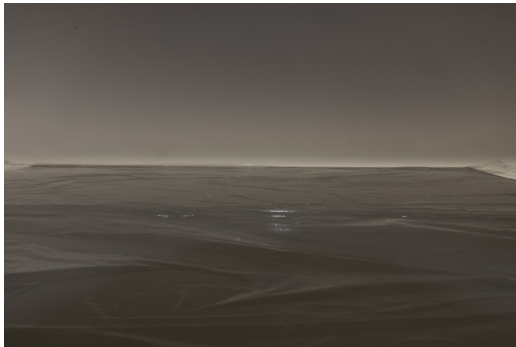

Fig. 4.8: Studio test shots for *West*, 2008.



Fig. 4.9: *West*, 2008. Inkjet on archival paper





Previous Page:

Fig. 4.10: Studio test shots for *North*, 2008.

This page:

Fig. 4.11: *North*, 2008. Inkjet on archival paper.

thing, although the exact form is not yet conceived. In the first instance, the material seems to be moving along its own trajectory. Initially these images form from the coalescence of materials that are gathered as the first task is prepared for, but as the images form, new matter seems to be drawn in that was not seen as useful before. At first they appear to be drawn from the nearest reaches of the space that the work is being created in. Later they will be drawn from the all of the various rooms in the house.

The emergence, from the quasi-chaos, the matter (and *mattering*) of these surroundings, a *some-thing* appears. Sometimes its presence is so matter-of-fact that one scarcely registers it, like the elastic band left on a table. But then it is in my hand. Perhaps I meant to move it? It is old, and thin, and the colour of sand. It now rests at the base of a pile made of ashes and tea leaves, looking like something washed up on a beach. The caulk that fixed the wall where a hook was removed opening up a gaping hole of plaster is now the material that also binds the mass of objects on the box, which forms the shelf and the sea on which these objects sit and where one of us tests the possibility of using that hook to pin a board. This forms the side, against which the flashgun is used to bounce the light, and later it will become the base that supports the next set of objects whilst its former place is taken by a sheet of drafting film. From this is also fashioned a diffusing filter for the flash. And as the sheet is pinned I smoke the cigarette, whose eventual stub will form a part of the work that will be called *55°N*, (fig. 4.12).

Things gather in constellations, held together in shifting relations. Some are human, some are not: hook-board-reflector-light-box-photo-glass-sea; light-box-drafting film-glass-hand-switch; light-box-drafting film-glass-cling film; board-reflector-hand. Simultaneously, images are emerging (tripod-camera memory-lead-computer-software-memory-software), at first flickering and blinking on a small screen at the back of the camera, then on the screen of a laptop. These images begin to settle into apparent representations of islands, although they also hover between matter and the identifiable forms of islands. As the images appear they *take* form, they move towards molarity, towards idea (fig. 4.10). Island images are forming constellations with other images as they cycle across the screen, as the hands that move the mouse

pointer, scroll the pictures appear side by side one another, they reflect back on each other, and on the constellations of materials on and around the light box.

[T]hrough creative practice, a dynamic material exchange can occur between objects, bodies and images. In the dynamic productivity of material practice, reality can get into images. Imaging, in turn, can produce real material effects in the world. (Bolt, 2004, p.8)

The image(s) on the screen possess a different luminance to the objects on the box, they appear internally illuminated. These digital images are not without material agency, we might remark on their ‘flatness, stillness, ephemerality’ (della Dora, 2009b, p.351; cf. Rose 2003, 215, Sassoon, 2004), their sharpness and colour-saturated luminosity. My wife brings new objects from around the house, ‘what about these?’, she asks. Objects are coming in not just from the house but from the garden too, in what will later become *South* (fig. 4.14), a handful of chickweed is scattered on a yellow rubber glove, the glove rests on an inkjet print of a map. The map is a remnant from the previous project that now cuts across this emerging island, so too do the postcards of popular Dorset tourist sites bought in the expectation of creating an entirely different work. In *23°N* (fig. 4.13), the colours of the postcard images, the green of the lager can and the orange of the map pin appear to form a chromatic tendency towards over-saturation. The images call for colour saturation and the intensity of activity now moves towards the screen, whilst on the light-box molasses slowly leak over a crumpled postcard and across the glass.

Intercessions

A book with Claude Monet's *Water Lily Pond* lies open on a wooden bench a meter or so away from Ettinger's canvas. "A Friend" she calls the image. (Manning and Massumi, 2014, p.63)

Manning and Massumi observed artist Bracha Ettinger working on multiple paintings at the threshold between the inside and outside of her house. 'What is the status of this outside?' Manning and Massumi ask, '[t]he outside is not in juxtaposition to an outside: its coming in turns the inside out' (p.64). But the threshold is not simply the visible meeting of extents, even shifting ones. 'The outside is an intercessor. It is felt more than seen... [i]t is force before it is form, participant, enabler, disturbance before it is a figure' (ibid.). Whilst Ettinger's house sees the comings and goings of guests, other 'friends' are gathered on the walls of the studio, on the pages of open or shelf-stacked books, on the sounds emanating from the music player or the cup of iced coffee she holds. Monet, da Vinci, Lacan, Bach, Hanoch, Radiohead, '[t]he intercessor is a complex singularity that activates a process, a force that acts as a differential within an ongoing movement of thought' (p.65). For Susana Nevado the intercessors may come in the form of the holy cards, the images from books on sadomasochism, bondage and tattoos (p.66), a voice on the television, a column in a newspaper (p.93), as much as the visits by Kontturi and her other models: 'Many kinds of people enter her art-making: there are people who visit her studio while others connect to it via emails, phone calls, through news media and pictures in exhibition catalogues' (ibid.). Manning and Massumi describe how these images, sounds and texts escape direct representation, they do not figure in the works but remain at the 'threshold of thinking and feeling', for them 'Monet lies open, not to be looked at, but to be thought-felt' (Manning and Massumi, 2014, p.65). Taking this further they explain that it is not Monet the impressionist, the painter *pre-defined* that is the intercessor—the friend—but his 'greening', the vibrational light between the green and the violet of the *Water Lily Pond* that becomes the 'force for activation' (p.68) in Ettinger's paintings, as with Nevado, who remains

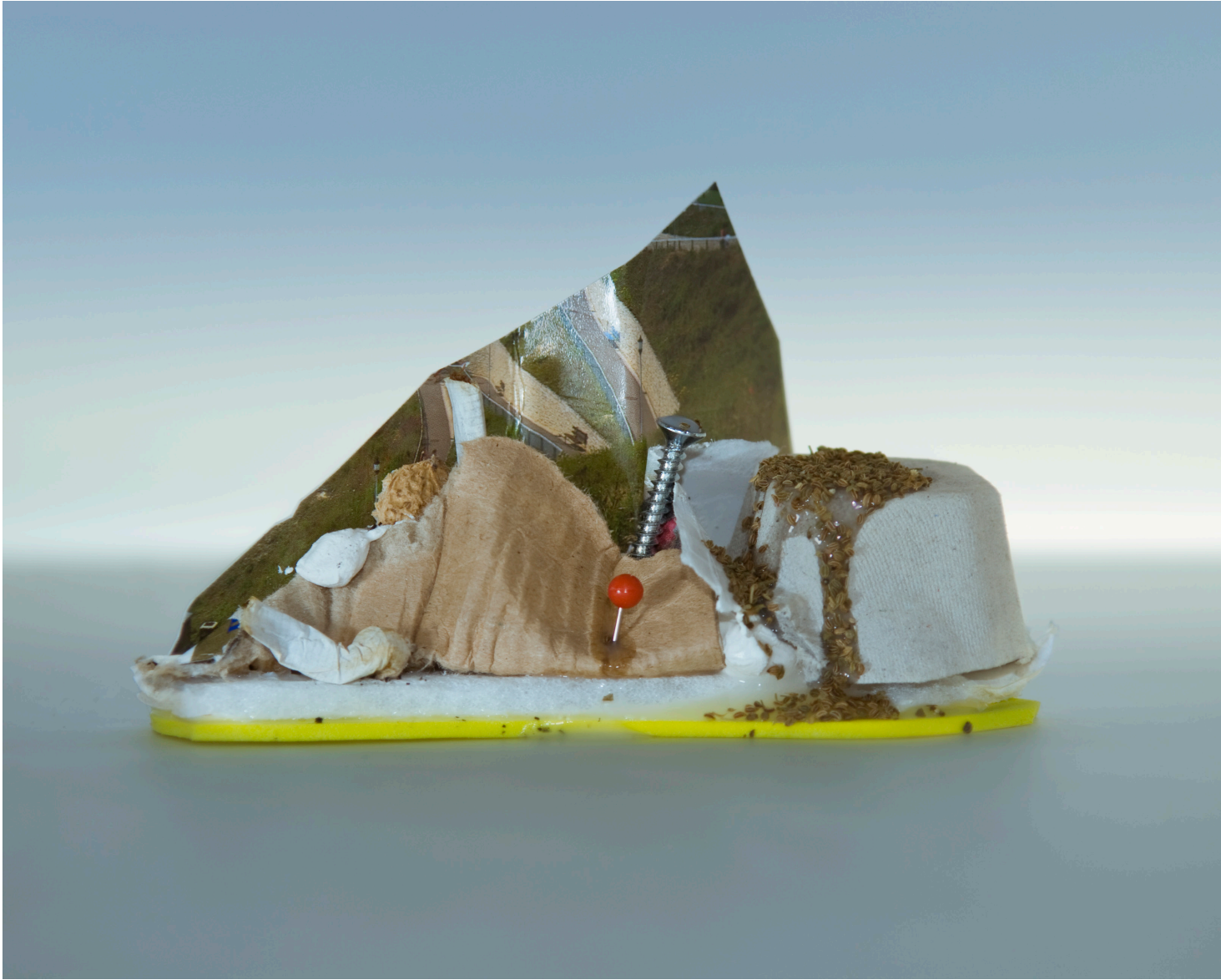

Fig. 4.12: *55°N*, 2008. Inkjet on archival paper.

oblivious to the sexualised symbolism of Anton Tàpies imagery but is caught in the thought-feeling of the layered material—the saffroning hues (Kontturi, p.98). These intercessions work against the determining of an enclosure, they spread across the threshold: ‘outside does not exist as such. It participates, it activates. It is always and only relational’ (Manning and Massumi, p.65).

In the middle of the creative moment, in which artefacts emerge not as fully formed ideas, but partial, *deformations* that ‘escape the outline’ (Bolt, 2004, p.136) I make something of a *speculative* pivot—I turn towards the unfolding of the event. As Massumi puts it:

To speculate is to turn in on yourself. You turn in, in order to connect immanently with that which is absolutely outside—both in the sense of belonging to other formations monadically separated from your present world, and in the sense of what may come but is unforeseeable. (Massumi, 2011, p.80).

This seemingly reflexive turn stirs in the growing awareness of my own participation in the un-calculative actions that momentarily organised into the event of making work. But in this moment I don’t escape the unfolding event—I don’t ‘get outside’ of the event in order to understand it. My sense of the event unfolds in my experiencing of it, its rising to a crescendo, its dissipation and re-uptake in the now-forming moments of the next event. This, perhaps, is why I am finding it difficult to explain what I am doing in the studio. What the *work* is doing. By turning attention to an immersion in the studio-event, the research began to emphasise the epistemic potential of active experience. Instead of grounding knowledge generation solely in an analysis of the representational aspects of these images and objects, I began to think more about how an attentiveness to the situations in which ideas were formed might offer alternative ways of understanding the outcomes I was producing. This inward-turning has the potential to unsettle the notion of a position for the researcher that is outside the fray of unfolding events.

Geographer Derek McCormack (2003) finds himself immersed in the continuous playing out of moment in a Dance Movement Therapy (DMT)

session, his original ideas of giving voice to, or representing the experiences of, the participants is challenged by the ‘wordless intensities of DMT’:

...what I needed to do was to become responsive to different surfaces of attention rather than seeking to go behind or beyond them, that the intensity of such attention could be as important as depth of insight, and that what one folded in to an encounter with DMT was as important as what one found out. (McCormack, 2003, p. 493).

Whilst McCormack’s initial disciplinary imperatives suggest a research position that is one step removed from his own kinaesthetic involvement in dance, as he becomes an active participant in this movement-experience McCormack tells us he becomes not only attentive to movement, but attentive *through* movement (ibid., p.498, emphasis in the original). But the affective intensities of this environment are not easily recovered and represented, in fact he finds that there is ‘never... an appropriate point at which to say “stop for a moment and tell me what is happening here?” or “what does it mean for you to be moving like that?”’ (p.493), neither does a critical exposure of hidden power relationships behind these enactments help to explain ‘the very processes that animate such a practice to begin with’ (p. 502). The notion of ‘event’ is useful here in that it extends a way of thinking about the taking-place of both practice and spatial experience. Event opens out a way of considering the processes of activity and change (Anderson and Harrison, 2010, p.19; Massumi, 2011, p.1), and process in which we are not simply witness to the unfolding moment, but are ‘attentive to the fact that we become with events’ (J-D Dewsbury, 2003, p.1915).

How does one ‘step back’, so to speak, from the immediacy of the experience? How does one form a sense of it? For Massumi the event is a means of displacing the subject-object divide that is rooted in a hierarchical ordering of practices in both the sciences and the humanities. One which extends not only in the cultural distinctions in knowledge production between these cultures, but also the disciplines within them, a separation of rational-empirical methods and speculative or theoretical approaches ‘dismissed by the other side as “merely” subjective,’ (Massumi, 2011, pp. 11.) Massumi



Fig. 4.13: 23°N, 2008. Inkjet on archival paper.

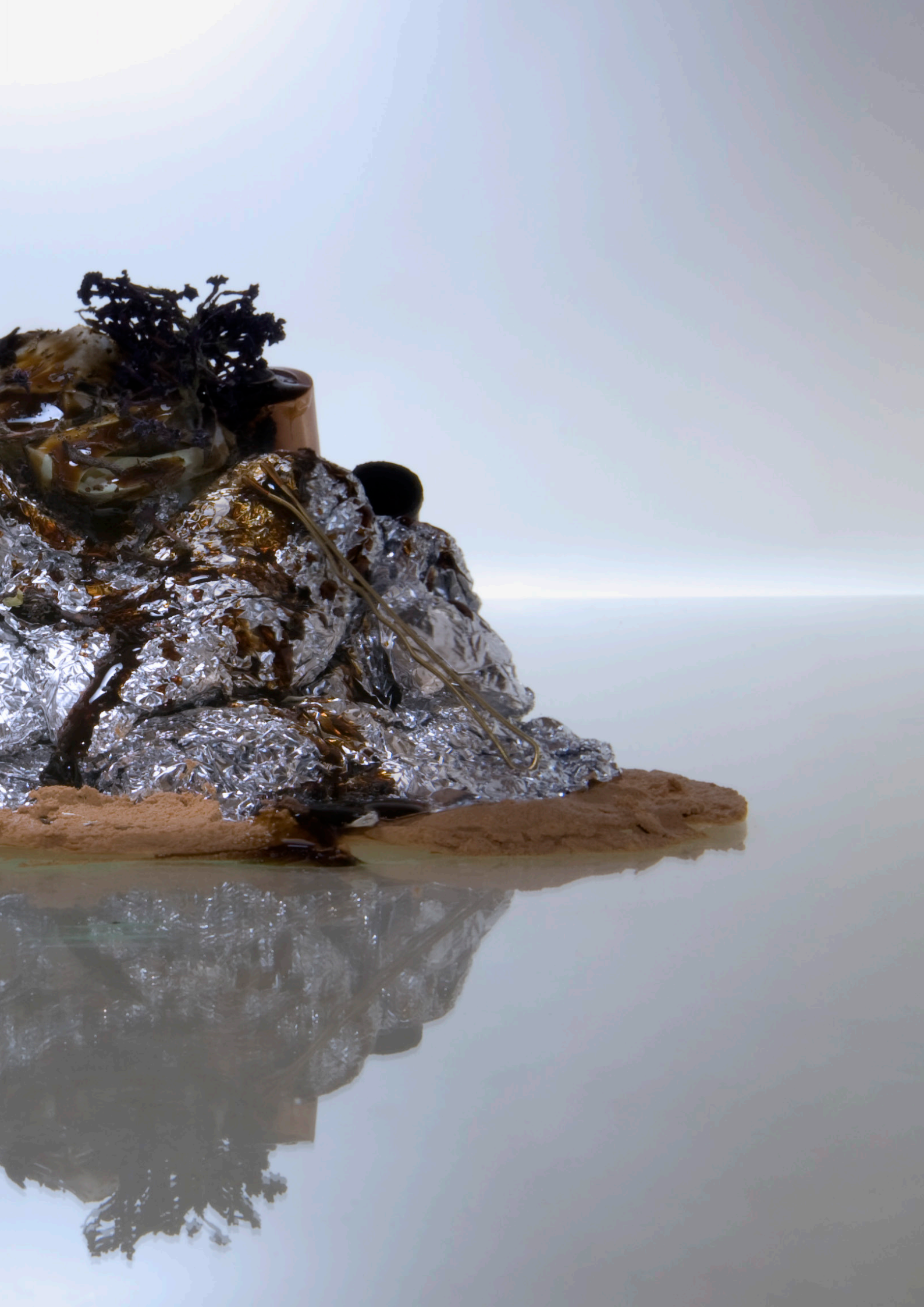

Fig. 4.14: *South*, 2008. Inkjet on archival paper.

Overleaf:

Fig. 4.15: *East*, 2008. Inkjet on archival paper.





appeals for an understanding of the real from within the threshold of the coming-together of experience. The issue is the way in which this change taking place is said to be experienced, since once categories of knower and known are mapped over subject and the object each is assumed to be irreconcilably isolated, in other words '[h]ow can the subject cross the divide to reattach itself to the objectivity "out there" on the other side?' (p.7). However, Massumi does not hope to *overcome* this subject-object divide, but rather 'displace' it, by considering how objective and subjective might relate to each other as 'pulses of process'. The content of experience is already implicated in 'change taking place' (p.1), and thus 'to begin to think life, we must begin in the middle with an activist sense of life at no remove: in the middling immediacy of its always "going on"' (ibid.). The point at which the going on of the world becomes perceived, felt, registered, is at the threshold of experience, at the cusp of the event-in-formation:

From something doing to the bare fact of activity; from there to event and change; then on to potential and the production of the new; coming to process as becoming. Then, a major twist. The straight run encounters turbulence: process as becoming is not just creative activity, it turns out. It is self-creation. More than that, the *self-creation* is "enjoyed." The principle of unrest eddies into something we would be forgiven for suspecting is not unlike an aesthetic appreciation: an enjoyment of creativity. (Ibid, p.2)

Massumi's account is one in which pulses of recognition and anticipation overlap in phases to provide a (co)-feeling of dynamic unity and forward momentum. The *how* of the event 'co-felt, in the immediacy of its *now* unfolding', (p.4, my emphasis). This relay between co-occurring and co-perceiving becomes a dynamic unity, a relational coherence. Massumi describes this in terms of 'self-enjoyment', an emergent sense of subjective self-creation, and in this way subjectivity is understood as inseparable from the event:

The "subjective" is not something preexisting to which the event occurs: it is the self-occurring form *of* the event. The dynamic unity

of an occasion of experience is its “subjective form.” Actually, there is no “the” subject. *There is only the event as subject to its occurring to itself* (p.8).

Certain phases of the creative process not only emerge through, but also turn on, and begin to assimilate the occurrent as a conceptual entity in ‘successive *takings*’ of experience (Massumi, 2011, p.7); that is there are continual shifts in the conditions in which these acts occur, and the way they form the *semblance* of an experience. Even as the rolling-over of successive events begin to coalesce into the feeling of a ‘work’, and the production and reproduction of successive photographic images begin to brink in a feeling of satisfaction at reaching some ‘final’ form, new possibilities are already anticipated. There is a simultaneous arcing back as things continue forward, the recognition of an image that has newly formed as both a variation of previous states of formation and a prefiguration, or prehension (Manning, 2009, p.7; Sennett, 2009, p.154), of future (de)formations.

In this chapter some of the discourses developed in “Walking, Drawing & Map-Making” that helped to shape an occurrent sense of practice, and that displaced the idea that artwork might be thought simply as a response to the environment, moved from the ‘arenas of chance encounters’ (Massey, 2005, p.179) in the public spaces of the city, or even the Dorset countryside, to the apparent enclosure of the home studio. In order to show the vitality of these spaces, and their resistance to definitions of interiority and exteriority, I have brought together a series of ‘followings’ and narrations that contest the notion of the studio as an isolated chamber inhabited by a singular, masterful mind.

Some of these ideas were paralleled in the developments made in the work, and in the volatility and indeterminacy of the matter that began to coalesce into the works for the exhibition *Borderlands*. But although there was a sense that materials, works-in-formation, and various other human and non-human intercessors continuously travelled across the thresholds of the studio-slash-boxroom, less attention was paid to the ways in which the

Islands

artefacts being formed toured between locations stored on memory sticks, attached to emails, printed on paper sheets, and on flyers, on brochures and bundled into packages of marketing material, and packed into frames to hang on gallery walls. In the next chapter, and the last of these three movements, the thesis turns towards these mobile assemblies in order to extend the proposal that the 'works' are not just the creation of finished or final pieces, but part of a continuous meshwork of interactions through which 'works' are packed and unpacked, circulated and consumed.

5. HOME & ABROAD



Home and Abroad

In this final movement the emphasis shifts from the studio and back towards the potential site or location of exhibition as I began work for an exhibition in Sydney, Australia—and off-site project curated by the Peloton Gallery in Sydney titled *Drawing Lines in the Sand*. I was invited to be a part of this show at the behest of Claire Taylor, the exhibition curator, and as the only British exhibitor there was a sense that my part in this show might also acknowledge, in some small way, connections between Australia and Britain.

Whereas the previous chapters have acknowledged the relocation of materials between places of production and exhibition, this chapter turns towards these movements in order to contemplate the ways in which they travel, as both ideas and as physical things. I consider how they join with, and are remade through new relational compositions. In doing so I gather up and extend a number of strands of thought from the previous chapter, in particular those around the studio, but here I also turn towards the objects that are both enmeshed in and emerge from these practice events.

Taking as a cue the gifts brought back from Australia by my grandmother, I explore landscape representations that travel on the physical surfaces, in this case on tea towels and ceramic artefacts. As with the photographs created for *Borderlands*, the images that develop in this body of work are created from compositions of gathered matter. Here, however, the materials that were brought or found their way into the studio were not the scraps of studio and household detritus used in the images for *Borderlands*, but a collection of hand-me-down ceramics and knick-knacks bought in local charity shops, which carried images or forms that offered a certain idea of local or national landscape. Many of these objects were already inclined towards transition, created to be portable or to be displayed in frames, on walls or in boxes. Through the work of geographers Veronica della Dora and Harriet Hawkins, art historian W J T Mitchell and artists Thomas Gainsborough and Gayle Chong Kwan, I set out a series of connections between the collecting of

‘found’ objects, the construction of landscapes and the circulation of these on and in various material supports and forms, as I follow the progression of a body of work from the studio to exhibition.

Gifts from Australia

In April 2010 I was presented with the opportunity to produce work for a off-site project that would held on a real island. It would be a group show on Cockatoo Island, a national heritage site in the middle of Sydney harbour, entitled *Drawing Lines in the Sand*. The invitation followed a discussion around the island as a powerful image in the European imagination, one that offers both the promise of rebirth and the potential for harbouring our deepest fears (Gillis, 2010). The earliest discussions centred around the history of Cockatoo Island itself, its previous incarnations as a naval munitions and shipbuilding yard, penal facility and a reformatory. We also talked of the remains of buildings and infrastructure that hark back to a maritime worldview, and yet seemed to be the antithesis of the utopian island of Enlightenment explorations (cf. Withers, 1999).

As a contributor, I would be the only artist not from Australia, which also raised questions about whether my possible responses might take account of this distanced view, particularly as I had never been there. Whilst my previous works, and particularly the images produced for *Borderlands*, provided a springboard for discussions about the kinds of lines along which artwork might



Fig. 5.1: Tea towel given by my grandmother on her return from Australia.

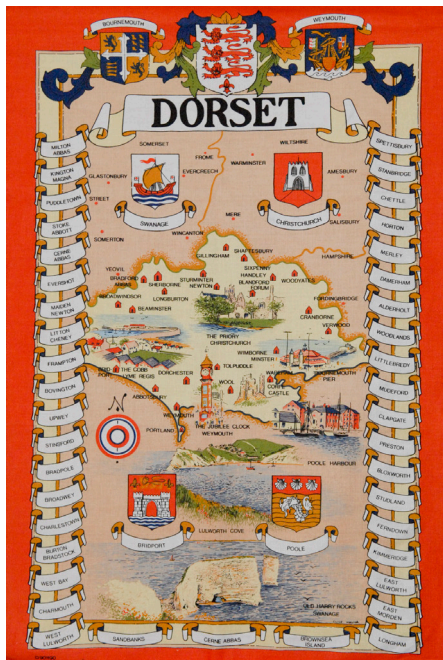
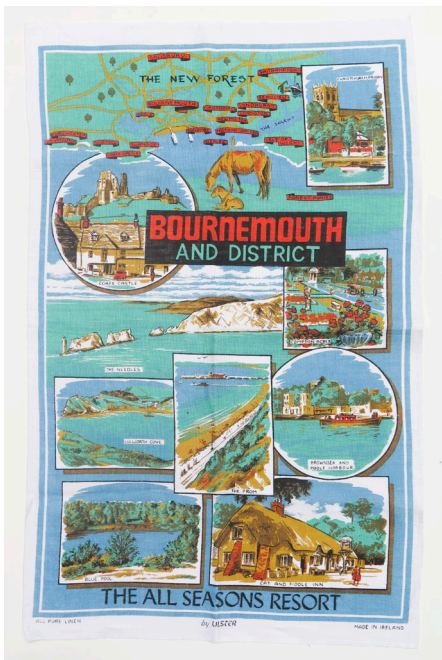

Fig. 5.2: Various tourist tea towels.
Collection of the artist

develop, my own childhood images of Australian flora and fauna began to exert a certain centrifugal energy. The continent of Australia had provided a wealth of childhood imaginings. My aunt, who had emigrated to Melbourne in the sixties, or our cousins, would occasionally visit, and my grandmother would make periodic return trips to Australia. The toys, books and souvenirs that returned with her, succeeded in populating fantasies of this continent with bright green Eucalyptus, burnt red soils, and hybrid creatures. In the iconographic objects such as printed tea towels, paperweights and other artefacts that came back from Australia, images of landscape became mobile and material presentations of a place which, whilst present-at-hand in the feel, the smell and the 'look' of each object, was nevertheless impossibly distant to a child growing up some 10,000 miles away in rural southwest England.

The objects that would return with my grandmother from her own souvenir hunting trips, getting a little something to take back for the grandchildren. Amongst the various souvenirs we received were toy koalas and a kangaroo, an aboriginal hand carved wooden crocodile decorated in pokerwork, picture books and a number of tea towels bearing representations of indigenous flora and fauna either in the style of European natural history illustration, or as reproductions of aboriginal artwork (fig. 5.1). Perhaps unusually, the tea towels seem to have had the most memorable affect on me. Despite their obvious decorative qualities, these were objects that were used functionally in our household, and as children growing up in the late nineteen seventies we would be co-opted in helping to wash the dishes following most family meals. Around the draining board all three of us children were tasked with carefully drying the crockery before putting it away. During these chores, perhaps distracted moments would find me staring at the pictures of Australian animals on linen drying sheets, temporarily fixated on some other imagined place.

The tea towel which had been the 'extraordinary object' (Gordon, 1986) that returned as a gift with my grandmother, became the point from which I began to reconstruct a narrative of that childhood moment. The idea of an exchange began to underscore my approach to this project, I felt there was

a need to consider how the creating artistic works might provide a means of exploring the exchange of *ideas* of place that travel alongside artefacts (Cresswell, 2014). That the objects had been a gift by our grandmother meant that we had no hand in their original selection, and since they also came from a place we had never been to, they were not mementos of a personally witnessed event or reportable event. Furthermore, the gift seemed to imply a riposte, and a deferred one at that. Yet to say this would be an exchange of gifts is perhaps misleading, since it would not be accurate to describe the creation and circulation of the art works produced for this show in exactly the same terms as the act of gift-giving, in which the act of gifting infers a return. My late grandmother gave us the Australian souvenirs, I could no longer reciprocate this act directly to her, but the idea carried with it a means of advancing some latent connection between myself and the Australian continent.

Theorising the act of gift-giving is well explored theoretical territory, certainly within anthropology, and is often seen in terms of the meanings these acts confer on our social relationships (Mauss, 1954; Sahlins, 1972; Gregory, 1982; Sherry, 1983; Bourdieu, 1990; Carrier, 1995). For anthropologists such as Marshall Sahlins (1972) and Charles Gregory (1982) there is an inalienable quality to the gift that separates the gift-object from the 'commodity', by binding the object to the giver (cf. Strathern, 1988; Baudrillard, 2003). However, more recently these separations have been broadly contested, with arguments being made for far more fluid ontological distinctions (Appadurai, 1988; Kopytoff, 1988; Carrier, 1995; Gell, 1999; Goddard, 2000; Miller, 2001). The souvenir as gift provides one such example of the flux between object and commodity, bought in one place as a commodity, exchanged as a gift and, perhaps, even re-sold as a collectible.

Indeed in this particular project, whilst I began with the memory of a gifted souvenir this largely provided the impulse to connect with various accumulations of found and bought objects, photographs of local landscapes and personal narratives. A large number of the artefacts that would later appear in the photographic works for *Drawing Lines in the Sand* came from charity shops, recycling centres and antiques stalls in various North Dorset

towns. They had already found themselves back in the second-hand market, and their various biographies had left visible physical changes to their surfaces. If the *idea* of an exchange of souvenirs had percolated into the first tentative studio ventures, it was not simply in the symbolic or economic function of gifting that was in question, but in the way that exchange mobilises objects, and in the capacity for these objects to act as agents: to become ‘enmeshed in, and active in, social relations, not merely passive entities in these processes’ (Edwards and Hart, 2004, p.4).

As it would be the various incarnations of artworks, rather than the objects themselves, that would be emailed, mailed and eventually shipped to Australia, I hoped to find a means of emphasising the way in which souvenir objects enact placial mobilities through touring and being toured, or as Michael Haldrup & Jonas Larsen describe it:

Places to tour are themselves toured by touring actors, objects and imaginative geographies materialized and mobilized in and through photographs, films, television programmes, souvenirs, clothes, food and so on. (Haldrup and Larsen, 2006, p.282)

Certainly tourist knick-knacks have the capacity to tell us something about place often through the iconographic images, stylised maps and picturesque landscapes that are imprinted or encased on their surfaces. There is in their rootedness to specific public sites or events, or their retelling of local cultural practices, an idea of place intended for mass-consumption. Indeed, literary critic Susan Stewart (1993) urges us to make such a separation between souvenirs of ‘exterior sights’ and those of ‘individual experience... most often are samples’ (p.138) in order to describe a transformation between the representation of a public, culturally articulated site and the personalised experience of possessing a record of that event at that site. For Stewart, these representations remain partial, a never-to-be-reconciled evocation of a ‘now-distanced experience’ (p.136), a partiality that is supplemented by narrative, but not the narrative of the object itself, rather the narrative of the person who owns it. It is a second-hand narrative that ‘creates a myth with regard to those origins’ (ibid). The narrative generated by the souvenir always reaches

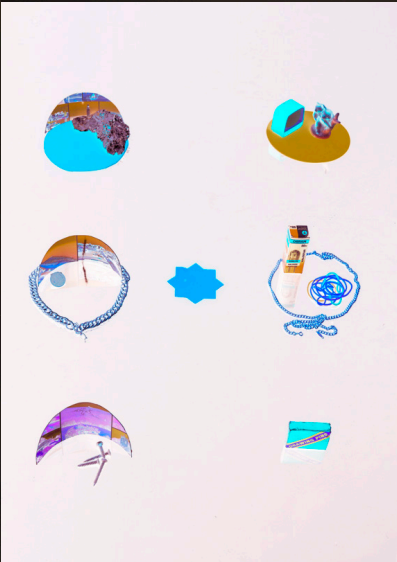
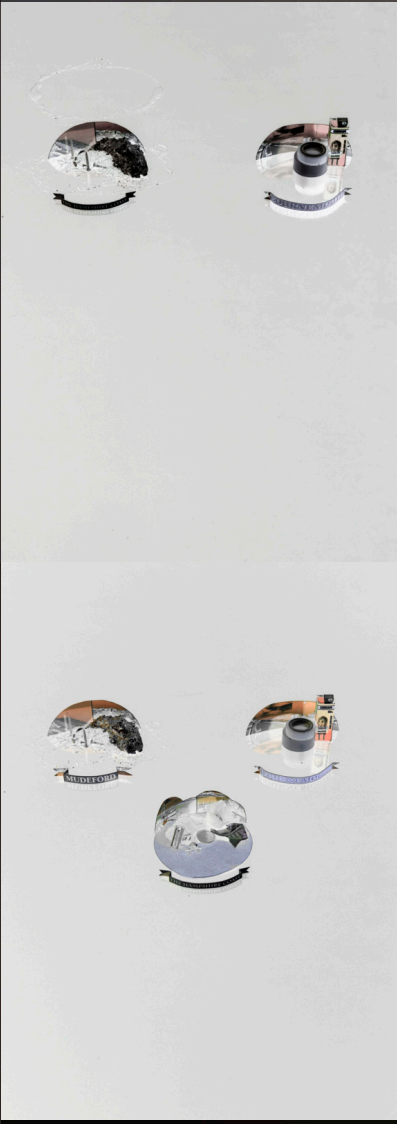
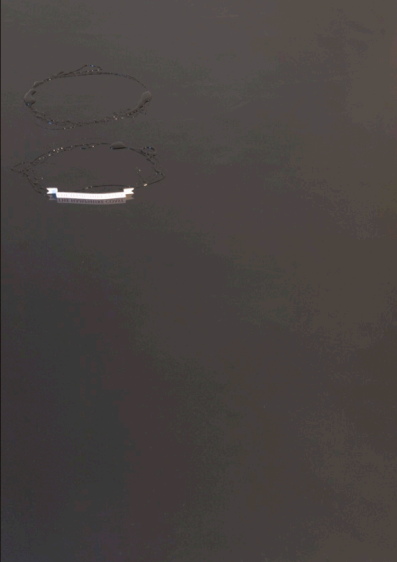
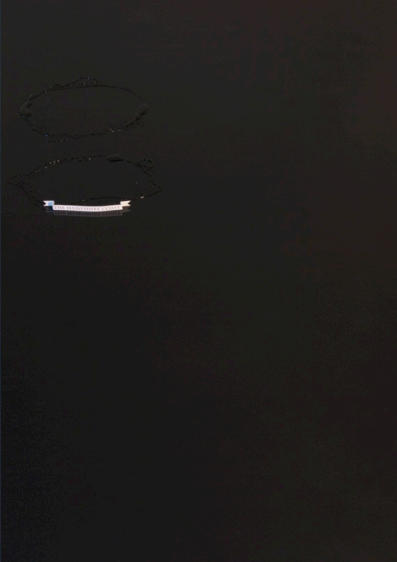
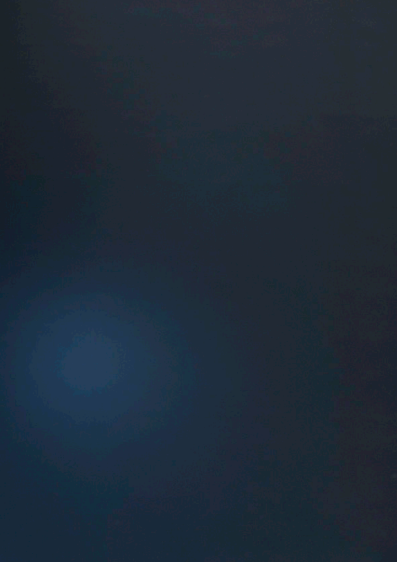

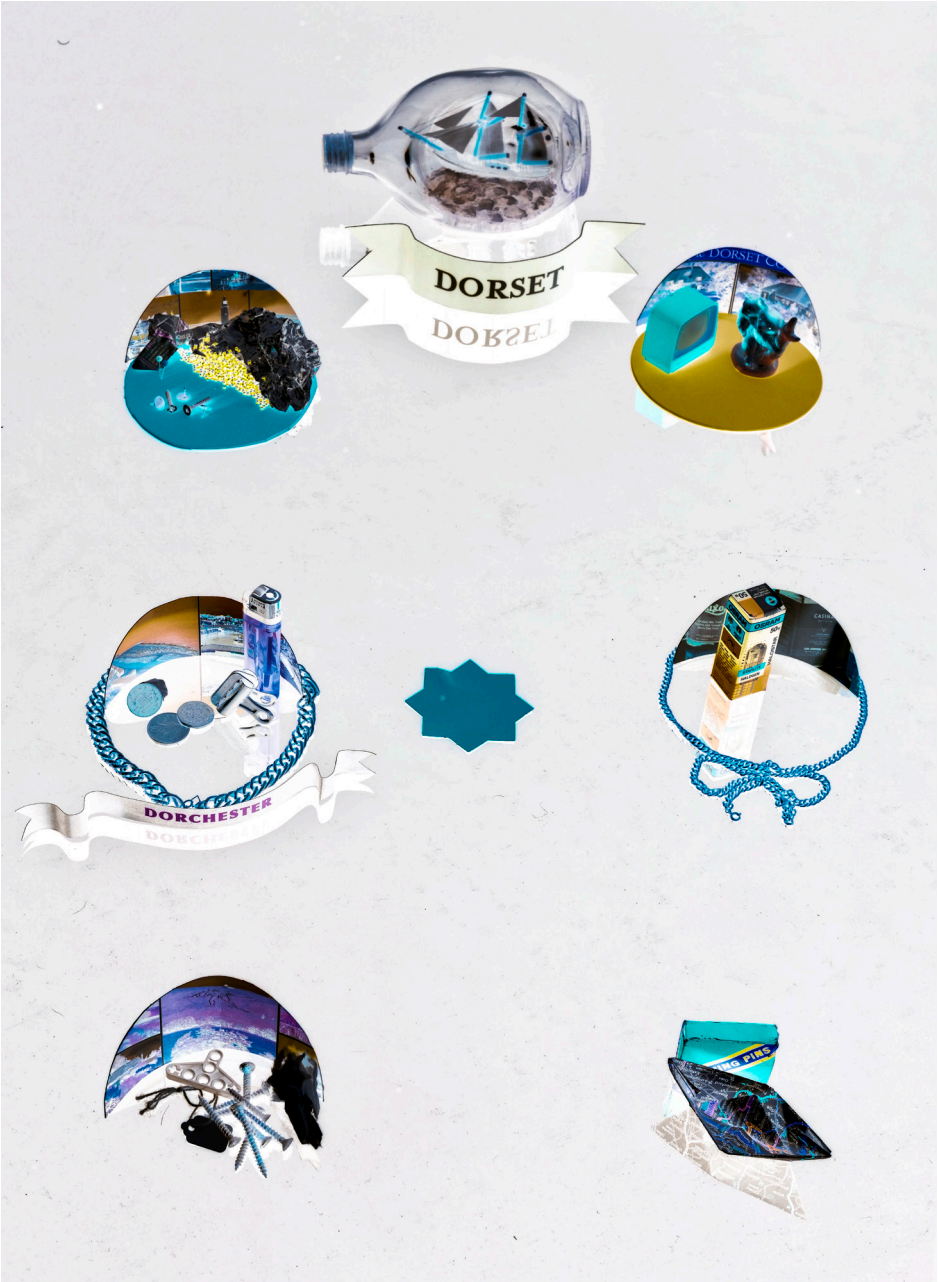

This page and previous:
Fig. 5.3 (i-xvii): Studio test shots.
Attempts to recreate a tea towel-like image using bought and found objects.

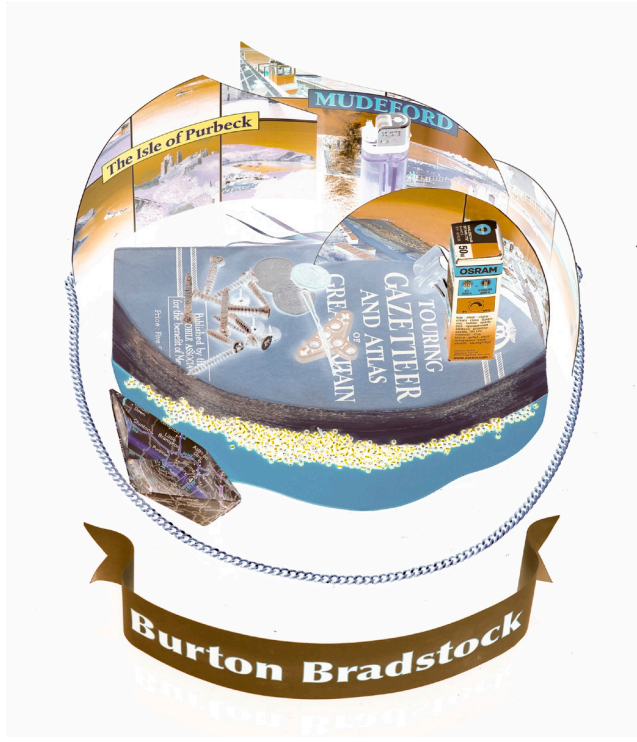
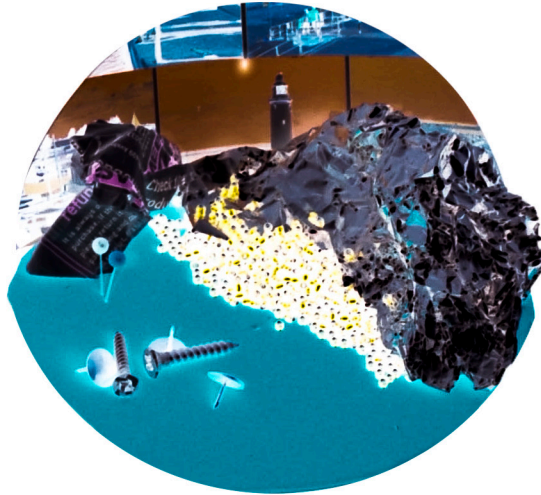

Fig. 5.4 (i-ii): Early attempts to create small vignettes that might resemble the small landscapes sometimes contained in frames on postcards and souvenir tea towels.

behind, ‘spiraling in a continually inward movement rather than outward toward the future’ (p.135).

Likewise, cultural historian Celeste Olalquiaga sees the relationship that the souvenir has with authenticity, or the authentic experience, as a partial one, although Olalquiaga’s souvenir is perhaps closer to Stewart’s descriptions of personal mementos. Olalquiaga points to the aureatic power of the religious relic as a premodern counterpart to the souvenir. But if the commodification of objects of remembrance eroded their mystical charge, then mass production reduced them to kitsch, and whilst mechanical reproduction may have broken the exclusive link between an individual and an ‘authentic’ experience it only appears to have compounded our fetishisation of the experience of loss (Olalquiaga, 2002, p.84), by providing multiple identical objects that could be claimed as individual experiences of remembrance.

If the souvenir is a metonym for nostalgia, as Stewart and Olalquiaga appear to suggest, then perhaps the idea of nostalgia itself needs to be understood in more *constructive* terms. This is what geographers such as Alison Blunt (2003), Veronica della Dora (2006) and Alistair Bonnett and Catherine Alexander (2013) seem to argue for. Rather than simply being a regressive movement they see nostalgia as having the potential to be a productive force. Their revaluation of nostalgia as progressive as well as reflective is a move away from the idea of seeing it as simply bound to the past, and acknowledging its productive capabilities in, for example, the establishment of an Anglo-Indian homeland (Blunt, 2003), urban redevelopments in Tyneside (Bonnett and Alexander, 2013) or revitalising Alexandria (della Dora 2006). These arguments tend to focus on the *vital* attachments made by individuals to the city or ‘homeland’, usually in its (re)construction, but they point towards the dynamic capacity of memory and nostalgia—a capacity that ‘shapes human activity’ (Bonnett and Alexander, p.394), where present and future understandings of place come through a connectedness to the past. Bonnett and Alexander’s emphasis on productive or active tendencies acknowledge the capacity for nostalgias to operate in multiple strands: ‘simple’, ‘reflective’, ‘restorative’, ‘productive’, and ‘active’ (Bonnett and Alexander, p.393).

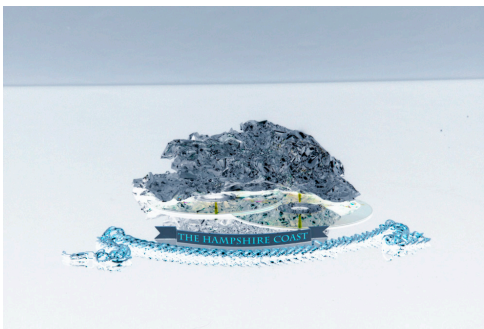
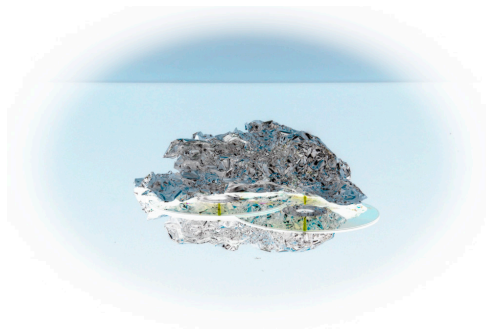
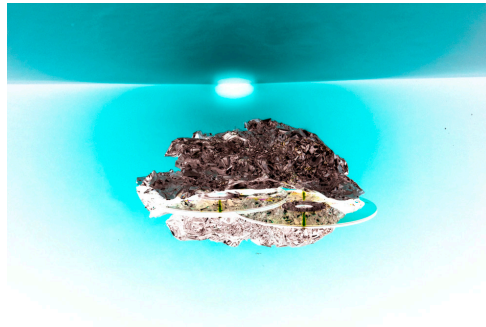
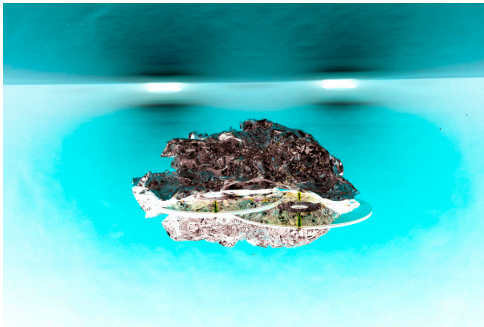



Fig. 5.5: *Portland Bill*, 2010. Inkjet on archival paper.

Previous page:

Fig. 5.6: Studio test shots for *Portland Bill*.

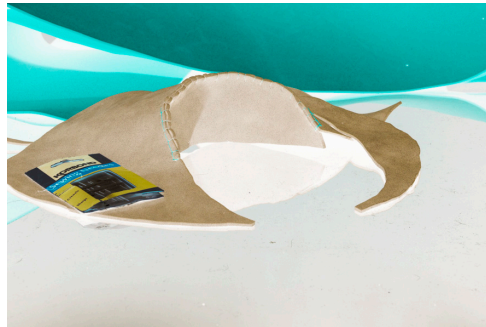
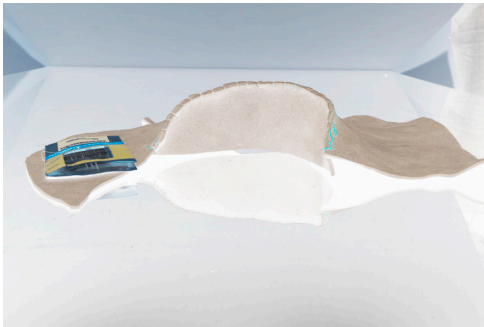
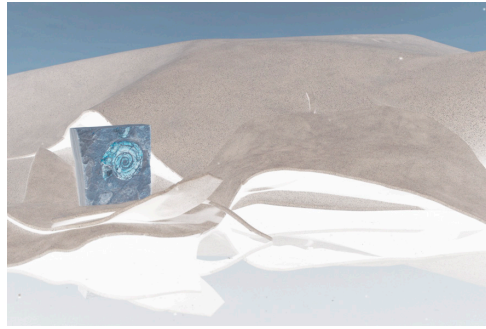
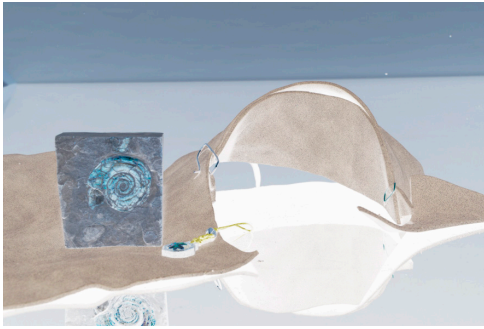



Fig. 5.7: *Lulworth Cove*, 2010. Inkjet on archival paper.

Previous page:

Fig. 5.8: Studio test shots for *Lulworth Cove*.

There is a more physical aspect of the souvenir that I wish to turn to, one that is tied to the more vital attachments made between nostalgia, place and memory, but one that takes account of the material that supports or creates these objects. I possess one of these tea towels (fig. 5.1), at one point in the research process my father sent me over the last remaining cloth brought back from Australia by my grandmother. The images are still legible, although the linen is full of holes. And whilst the linen is clean, enmeshed in the fabric appear to be the discolourations left by countless washed pots. The fabric smells familiar; it smells of detergent and of the drawer we kept our linen in. A soapy-woody smell. But it is, perhaps, a smell that reminds me of the family kitchen as it is now. Collecting objects from second-hand shops and market stalls was not an activity that revolved simply around the images of landscapes they often bore, but also on the forms and surfaces on which they were carried.

When I turned to the collection of things I had either bought or found, in order to be used to recreate souvenir tea towels (fig. 5.3) or landscape images, it was not simply for the images they bore on their surfaces—although there was a distinct attraction to the bucolic and the pastoral scenes that many of the later objects carried. From a fairly early stage there was an attentiveness to their materiality, as much as their iconography, which, in part, continued a materialist strand that began in the chaos of the studio. One significant line of thought developed from an interest in the work of geographer Veronica della Dora, whose text *Travelling Landscape-Objects* (2009b) lent its name to the title of a series of works produced for the *Drawing Lines in the Sand*. Whilst writers like Stewart describe the closely bound relationship between the souvenir artefact and the narrative that supplants it, della Dora turns our attention towards the material qualities of these objects, and considers how they are also mobile, rather than static, representations that are ‘able to travel around’ (della Dora, 2009b, p.335) and in the process works not only ‘deteriorat[e] in the course of their physical transportation...’ they also ‘change their meaning and form during their journeys’ (2007, p.288).

Della Dora’s work draws on both a geographic interest in the visual

(2009b, p.335) and a general shift towards more materialist modes of analysis that have percolated through the social sciences in the last two decades (Coole and Frost, 2010). In two papers that deal with travelling landscapes or landscape objects, *Putting the World into a Box: A Geography of Nineteenth-century 'Travelling Landscapes'* (2007), and *Travelling landscape-objects*, della Dora brings together a number of geographic and art historical strands in order to progress an argument that moves beyond a purely iconographic and representational analysis of landscape images, particularly those associated with tourism or touring 'objects' (2009b, p.334). Taking threads of post-representational thinking on landscape from geographers such as Kenneth Olwig (2002; 2005) John Wylie (2005) and Sarah Whatmore (2006); on mobility from sociologists such as Mimi Sheller and John Urry (2006); and on objects from anthropologists such as Elizabeth Edwards and Janice Hart (2004), and Daniel Miller (2005), della Dora analyses various circulations and engagements with landscape-bearing artefacts from giant panoramas to postcards and paperweights.

To identify a body of theoretical work so directly in the title of a series of artworks was unusual for me, but it was less an obedient following than the recognition of a strand of materialist thinking that seemed to offer insights not only on the objects I was collecting, but also on how they had arrived, how they continued on their journey and how they might conjoin with other artefacts and images to form shifting narratives that might tell us something about the contingent and temporal nature of place. Narrating part of this journey involved not just the objects, but the images I made from them, which were shipped, mailed, uploaded and downloaded, and in the last instance returned in a very different physical state than they left. Furthermore, della Dora's *Travelling landscape-objects* contributed to a sense of the dynamic, nebulous conceptualisation of the studio by drawing attention to the trajectories of things as they entered and left the studio, extending beyond the co-constructive processes that enabled works to form into identifiable pieces, and turning towards movements of distribution and reception. This, I hoped, would have less to do with the images they carried and more to do with the form they took and the way they were presented, although in the

end it would also be their own deterioration that produced closer, but far less anticipated parallels to the work of della Dora.

The World in a Box

The life of images is not a private or individual matter. It is a *social* life. Images live in genealogical or genetic series, reproducing themselves over time, migrating from one culture to another. (Mitchell, 2005, p.93)

Photographs are both images *and* physical objects that exist in time and space and thus in social and cultural experience. They have “volume, opacity, tactility and a physical presence in the world” and are thus enmeshed with subjective, embodied and sensuous interactions... they occupy spaces, move into different spaces, follow lines of passage and usage that project them through the world. (Edwards and Hart, 2004, p.1)

Between the eighteenth- and nineteenth-centuries, European yearning for distant lands and changes of scenery grew faster than the industrial development of transportation that might take most of them there. Whilst imperialist expansion had stirred European imaginations about far-off lands and sublime landscapes, only a very small part of the British population had ever left the shores of these islands (della Dora, 2007, p.287). Leisure travel was still a privilege of the elite. For most people these landscapes would travel to them through stories, contemporary travel writings, illustrated newspapers, school texts, atlases, paintings and, towards the end of the century, in photographs and postcards. One form that was typical, however, was the box:

More characteristically, they also travelled in ‘boxes’; boxes of different shapes, materials and sizes: from wooden stereoscopic boxes inside of which one’s eye could wander from the bay of Naples to the summits of Himalaya, to alabaster peep-eggs embedding views of the Niagara Falls or Nightingale Valley; from miniature telescopic paper theatres displaying Parisian promenades and the monuments of Rome to the great panoramic rotundas... windowless circular buildings in which

the viewer could admire a 360° panoramic painting from a platform set at the centre of the building. (2007, p.288)

But these were not just geographic feasts for the eye, they were objects in their own right, objects that deteriorated during travel, whose meanings and forms were changing as they toured. Rather than simply being representations, this knowledge of other worlds, often recorded 'on the spot' (p.290; cf. Greppi, 2005), was packed and circulated by way of material objects 'never simply transferred but radically transformed from one medium to another' (p.288;).

For della Dora, the raree-showman provides the earliest examples of these mobile landscapes, transporting heavy 'peepshow' boxes. The box itself provided the closed hidden space through which these worlds would be glimpsed:

What all these boxes shared was their hidden and yet liberating spatiality; their physical containment and their ability to take the viewer further, visually and imaginatively. They all shared a wrapped-gift-box aspect, a sense of mystery and excitement behind their promise of a larger, more thrilling world (2009b, p.337)

And it is this idea of the portable, magical and instructive wooden box, which also finds its form in the peep-eggs and panoramas that pass from hand-to-hand and land-to-land, which provide a means of considering 'the idea of *landscape as a material and movable object*' (2007, p.290). Della Dora's intention is that we begin to think of these landscapes not only as iconographic representations, images that are culturally encoded in terms of the sublime or the bucolic, but also the way in which this great mass of circulating landscape images are carried as objects in boxes, attached to or embedded in glass, on photographic paper, on fabric or ceramic, as three-dimensional things:

Sold on postcards or porcelain plates, on small souvenir boxes or mugs; walking on the Hawaiian shirt of a passer-by, or riding on the side of a bus... landscape representations... bring about and circulate distant places, places that perhaps do not even exist. They make a non-presence present through their very material presence. (Della Dora, 2007, p.292).

It is in this very material presentness that della Dora finds enchantment (2009b, p.334), and through which she is able to pose the questions:

How does the materiality of graphic landscape representations ‘matter’? What happens when we set landscape-objects in motion? How do their movements and materialities participate in the shaping of geographical imaginations? Do landscape-objects have a social life? Do they keep their original meaning and function attached as they move around? (2009b, p.335)

An attentiveness to the circulation of souvenirs in my own family seemed to parallel these questions, one that also reached back to the issues that had been raised in relation to the map ontologies by writers like Kitchin and Dodge, and Kontturi’s analyses of the ‘mattering’ of Susanna Nevado’s studio work. By drawing attention to makings and mappings *as* practices and as events rather than stable objects or outcomes, these writers had emphasised their openness to continual re-making and re-mapping as maps and artworks are taken up in new contexts; new relational arrangements (Kitchin and Dodge, 2007, p.342; Kontturi, 2012, p.41). The ‘boxes’ I ended up exhibiting on Cockatoo Island, however, would not evolve as a direct response to the observations of della Dora, but through the less predictable interactions between material

images, found objects, digital processes and tracts of text that would form and re-form new constellations of relation throughout the project. So when I found myself staring at the images of bucolic landscapes printed on the sides ceramic tankards in a local charity shop, my arrival there seemed to be more chance than intention.



Fig. 5.9: *Exports Build a Prosperous Australia*, from Gardiner, 1958, p.46

Like most projects, preparations for work began with a sense that the new body of work would emerge by first

turning to the set of working processes that I had been using most recently, but on each turn I would draw together new references. For this reason I found myself in possession of a number of new dishcloths, bought from various gift shops in the surrounding area (fig. 5.2). Some bear cartographic outlines of the county of Dorset, shields bearing the arms of the local Councils and boroughs, banners proclaiming the names of towns and villages and graphic insets illustrating local landmarks, picturesque gardens and other visitor attractions. The image are often contained within borders that appears to emphasise the pictorial, and that lean towards display (cf. della Dora, 2009b, p.350; Peters, 2011, p.250).

In the ‘studio’ these tea towel took their position on the wall next to a number of other images. Some of these were postcards bought at seaside shops, small print outs of the islands made for *Borderlands*, an image of dairy produce taken from a late 1950’s Australian marketing publication (fig. 5.9), laser-jet prints of landscape images by artists such as Gayle Chong Kwan, Martina Lindqvist and Thomas Gainsborough (figs. 5.11, 5.12, 5.13 and 5.14), and a scan of the frontispiece from Thomas More’s *Utopia* (1516) (fig. 5.10), which seemed, for me at least, to share some resemblance with the image of Dorset or Hampshire on the tea towels (fig. 5.2). There appeared to be something deliberate in the act of selecting these images and sticking them to the wall, but the pictures themselves did not seem to form a coherent collection as such, or provide a clear indication of the direction the form the forthcoming works might take. Some had been gathered up as ‘friends’ (to borrow Massumi and Manning’s term) from previous projects—for example Chong Kwan’s images and More’s *Utopia*. Others were new additions to the studio, like the images of Western



Fig. 5.10: Frontispiece from Sir Thomas More’s *Utopia*, 1516.



Fig. 5.11: Martina Lindqvist, *Untitled, Rågskär Island* (series), 2008. Colour Photograph, 62cm x 76.2cm. Reproduced with kind permission of the artist.

Australian dairy produce, which appeared to extend alternative ways of visualising and perhaps practicing the constructions that might follow, in this case the careful arrangement of objects, or setting up an oscillation between place and ‘product’ (figs 5.3 i-xvii).

The postcards brought their own saturated mix of John Hinde reds, yellows, greens and turquoises, these are occasionally picked up in the dishcloths. Again, a movement that began in previous work but was taken up again in the early stages of new works, a movement that anthropologist Alfred Gell has described as a form of retention, a reaching back whilst moving onward (Gell, 1998, p.235). The saturated hues find expression in the reversal of colours (fig. 5.6) But it is not just the artificial colours of the postcards that are ‘tending forth, a force of expression’ (Manning and Massumi, 2014, p.68); names too are acting on the opening phrases of the studio work—

names floating on banners. The names are cut directly from postcards but set out like the dishcloth. The dishcloth and postcard resonate a ribbon-like tendency. The names point towards places, but these appear arbitrary, objects that are arranged above one caption later reappear above another. All at once the ground is cleared and new accumulations of materials begin. The name 'Burton Bradstock' is suspended under an old touring gazetteer of Great Britain (fig. 5.4ii). A chain forms a frame. A paper boat—a object created for a much earlier work—appears and disappears. More and more objects accumulate until, again, the collection is cleared.

In as much as I have a hand in the choices I make, the work also 'makes me' through the co-constructive processes that bring the human and non-human into constellations of relation (cf. Manning and Massumi, p.66; Grosz, 2005). And by the work I refer not only to the image that will finally stand in for all the potential possibilities for outcomes enacted in the studio, the single wall-mounted or page-bound image that carries with it the single titular reference to account for the entirety of movements of its antecedents. The 'work' is also the cross-cutting currents that cause the emerging images to flicker between one crystalline state and another. It is the totality of tea towel, postcards, Australian dairy produce, Chong Kwan and More, perspex, foil, paper boats and photographs of islands that, in this case, seem to act on the trajectory of events. 'Every practice', suggest Manning and Massumi, 'is a mode of thought, already in the act. To dance: a thinking in movement. To paint: a thinking through colour. To perceive in the everyday: a thinking of the world's varied ways of affording itself' (p.vii). And, as my experiences in the studio have shown, one does not act alone, one does so in collaboration, perhaps picking up intensities that find germ in arrangements between food photographers and the souvenir illustrators. In turn these begin to originate new potential collaborations, directions or lines of flight.

On Sunday 26th September 2010, after completing two works I have provisionally titled *Portland Bill* (fig. 5.5) and *Lulworth Cove* (fig. 5.7), I record a lengthy reflective monologue on a dictaphone. In this description of events I attempt to recompose their history, mark points of acceleration and change. At first the descriptions of connections appear well rehearsed:

paperweights... tea towels... gifts my grandmother would bring back from Australia... the concept of travelling landscape-objects, but then these begin to falter, speaking these relations becomes fraught with doubt. It seems harder to reconstruct the movement through which these ideas and objects seemed to gravitate towards one another. Instead the narrative turns to describing the image-making, and as I talk I click through the photographs on the computer: 'small islands... island groups... vignettes... scenes... grid... black perspex... previous work... glass surface... analogous to the sea... oil-black quality... colour reversed... strange separated... cutout... PhotoShopped...' (Audio Recording: Reflections on CT Island 1.mp3, 2010, 00:03:41). Even though the account I am giving is intended as a review of what *has* happened, here I appear to pick up new found threads in the oscillation between illuminated images on the computer screen. Yet when I turn again to deconstruct the decision making process it becomes evident that any logical chronology becomes increasingly difficult to pin down. Even shortly after the events through which a series of photographic images were formed, any real certainties about the occurrences that lead to their creation are not forthcoming. But as I continue to talk myself through the pictures on the screen, and recount the actions and arrangements new connections also begin to form. An itinerary of childhood and adult recollections that take off from the place names on the cardboard banners—holiday jobs working on local farms, or in pubs, crystalline moments, gruesome 'true' stories, the ghoulish, the sublime and the mundane.

When della Dora introduces us to the seventeenth-century raree-showman it is through the performance of storytelling and an absorption with the 'storied' object' that the assembled group are taken to distant lands:

For a penny, sometimes even for half a penny, passers-by were allowed to peer, as through a round window, at a magical world in miniature, with fabulous cities, and distant, or legendary landscapes. Their eye wandered through the landscape in the box, as the raree-showman directed this visual journey through his narration, sometimes accompanied by a concertina. (2009, p.336)

This miniaturised and circumscribed tableaux seems to offer the private experience of a tiny universe (witnessed within the public spectacle of the seasonal fair), in which this visual experience was both hidden *and* spatially liberating, able ‘to take the viewer further, visually and imaginatively’ (p.337). We might see parallels in this description with those Susan Stewart gives of miniaturised universes:

That the world of things can open itself to reveal a secret life—indeed, to reveal a set of actions and hence a narrativity and history outside the given field of perception—is a constant daydream that the miniature world presents. This is the daydream of the microscope: the daydream of life inside life, of significance multiplied infinitely *within* significance. (Stewart, 1993, p.54)

In this miniature tableaux the box may provide the limit to the space it occupies, as much as the diminutiveness moves it outside lived historical time, yet, for Stewart, its magnitude comes in the ‘vocality of signs it displays’ and its capacity to continually reflect the experience of interiority in the viewer (p.48; p.68). Stewart also reaches for the image of the island in order to further illustrate the closed realms of these models, since ‘[t]he miniature world remains perfect and uncontaminated by the grotesque so long as its absolute boundaries are maintained’ (p.68). However, these representations, in which the miniature is seen as both the metaphor for the ‘interior space and time of the bourgeois subject’ (p.xii), and for that of the island, creates an idea of an insular and separated subjectivity, one whose engagements with these objects is held at a distance, or internalised as reflections on one’s own yearning for what we lack, (Mitchell, 2005, p.57). However, Della Dora moves beyond a separation between perceiving subject and signifying image by turning to the very physical presence of the object, to its handling, and towards what sociologist Keith Hetherington calls ‘*praesentia*’ (Hetherington, 2003, p.1937; della Dora 2009b, p.344), a confirmation of experience through touch that Hetherington associates with touching relics at Holy sites, and as he puts it ‘[m]eaning and representation... come afterwards, and are post hoc rationalisations as representations of how we feel in this

haptic performance' (Hetherington, 2003, p.1941). Landscape-objects, in the familiar tourist form of postcards, paperweights, mugs or snow-globes that della Dora describes, 'make a distant non-presence present [by] their very physical presence... [they] are windows of dialogue with other realities: telescopes to other worlds, prostheses extending the capacities of the human body', and, '[l]ike the Latourian circulating references, they bring the there here, the then now' (2009b, p.344).

Gainsborough's "Showbox"

It is not only in mass-produced tourist ephemera, or in the images of distant lands that these circulating miniature worlds are found. Even as many Europeans yearned for the sceneries of remote empires, some turned their fantasies back onto more homely pastures. The use of optical technologies that allowed artists structure composition were increasingly prevalent in landscape painting during the eighteenth and nineteenth centuries, not only in the more familiar forms of the camera obscura and the Claude glass but also through the construction of instruments such as Cornelius Varley's Graphic Telescope and Thomas Gainsborough's 'showbox' (Bermingham, 2007; Helmreich, 2013), the latter sharing particular similarities to those della Dora describes. Gainsborough created his 'showbox', a boxed construction through which the picturesque images of fantasy European landscapes could be viewed sometime in the early 1780's (Waterhouse, 1958; Rosenthal and Myrone, 2002, Bermingham, 2007). He had become particularly enamoured with the illuminated stage sets of artist and theatrical designer Philip James de Loutherbourg, and made repeated visits to see de Loutherbourg's mechanical scenic illusion the 'Eidophusikon' when he first exhibited it in 1781 (Waterhouse, p.25; Whitley, 1915, p.369). Perhaps inspired by de Loutherbourg's theatre, and by an exhibition of painted glass by Thomas Jervais (Rosenthal and Myrone, p.256), Gainsborough created his 'showbox' by layering painted glass plates set before a silk diffusing screen. These were lit by candlelight and viewed through a lens at the front of the box and in a description that shares a great deal with della Dora's narration of the raree-

showman box, Michael Myrone tells us that:

[T]he experience was diffuse, with each individual painting contributing to a visual spectacle that the viewer physically inhabited and became part of. With the showbox, the relationship was one of intimacy and immediacy, of looking into the theatrically conceived closed space which the viewer could lose him or herself in. (Rosenthal and Myrone, p.256)

Whilst the optical devices such as the camera obscura and Varley's Graphic Telescope provided topographically accurate depictions of landscape, these worlds-in-miniature were Gainsborough's own purely imagined scenes, 'explorations of the medium of paint and its evocative effects' (Bermingham, 2007, p.204). He was not unaccustomed to creating illusions of landscapes using the most banal of objects. Art historian William T. Whitley provides us with a couple of accounts in which Gainsborough is said to have used model landscapes 'composed of broken stones, dried herbs, and pieces of looking glass, which he magnified and improved into rocks trees and water', and 'cork or coal for his foregrounds; make middle grounds of sand and clay, bushes of mosses and lichens, and set up distant woods in brocoli [sic].' (p.369; see also Hayes, 1980, p.25). The modelling of imaginary landscapes may have been in keeping with a more general shift, in the mid-eighteenth century away from the topographical and mimetic and towards the ideal (Helmreich, 2013, p.318). It is perhaps an interesting historical footnote that Gainsborough's 'showbox' should have been passed first to his daughter and then to Dr. Thomas Monro, whose tutelage and patronage shaped a new generation of painters including Thomas Girtin, J M W Turner and John Sell Cottman (Rosenthal and Myrone, p.256).

Gathering Landscapes

As my own work began to move towards vignettted images of small landscapes, like those inset into a map, new references began to collect around miniature landscapes. *Borderlands* had introduced me to the work of Chong Kwan, and in particular her *Cockaigne* series (2004) (fig. 5.13), whose landscape constructions



Fig. 5.12: Thomas Gainsborough, *Landscape in Suffolk*, c.1746. Oil on canvas, 66cm x 95cm. Kunsthistorisches Museum, Vienna.

using foodstuffs seem to move towards a more apocalyptic vision of excess. *Cockaigne* consists of a series of twelve photographs that provide a contemporary reflection on the 'Land of Cockaigne', a land of plenty where work is forbidden and food is abundant, even forming the bucolic architecture. Chong Kwan's depiction, in which pasta, ham, cheese, potatoes and oats are used to crudely sculpt the topography of this fabled land, tend toward the repulsive not the delectable. 'The lard of *New Atlantis*', explains Fiona Candlin, 'is beginning to sweat, the cheese in *Resort* looks plastic and slimy, the dried meat in *Babel* infectious' (2005, p.44). Chong Kwan's images are not a fantasy of opulence, they are nauseating depictions of excess, as Candlin points out these also serve as reminders of the practices of overproduction and overconsumption in our western corner of the globe. Candlin notes that, coupled with Chong Kwan's use of references to tourism, this work also asks us to consider how this fantasy of excess is at the expense of the labour and impoverishment of others.

The use of ordinary objects by both Gainsborough and Chong Kwan in order to construct fantasy landscapes, from cork and broccoli to pasta and cocktail sticks are, arguably, at the very root of the picturesque tradition. At least this is what art historian WJT Mitchell's (2005) surmises in his notion of 'founding objects'. Mitchell presents the 'objects of the picturesque', the poor thing, the rustic or the ruin, as playing a 'crucial ideological role... in mediating a double desire to own and renounce property, to possess the countryside without real ownership, to shape the landscape while preserving the illusion of chaos' (2002, p.117). The ordinary, the trivial, the forgotten, argues Mitchell, is the found object of the picturesque, and the found object



Top to bottom:

Fig. 5.13: Gayle Chong Kwan, *New Amazonia, Cockaigne* (series), 2004. C-Type print, 80cm x 100cm.

Fig. 5.14: Gayle Chong Kwan, *51d32m4sN 0d5m18sW, Veduta Romantica* (series), 2007. C-Type print, dimensions variable.

Images reproduced with kind permission of the artist.



Fig. 5.15 (i-ii): Early studio shots.

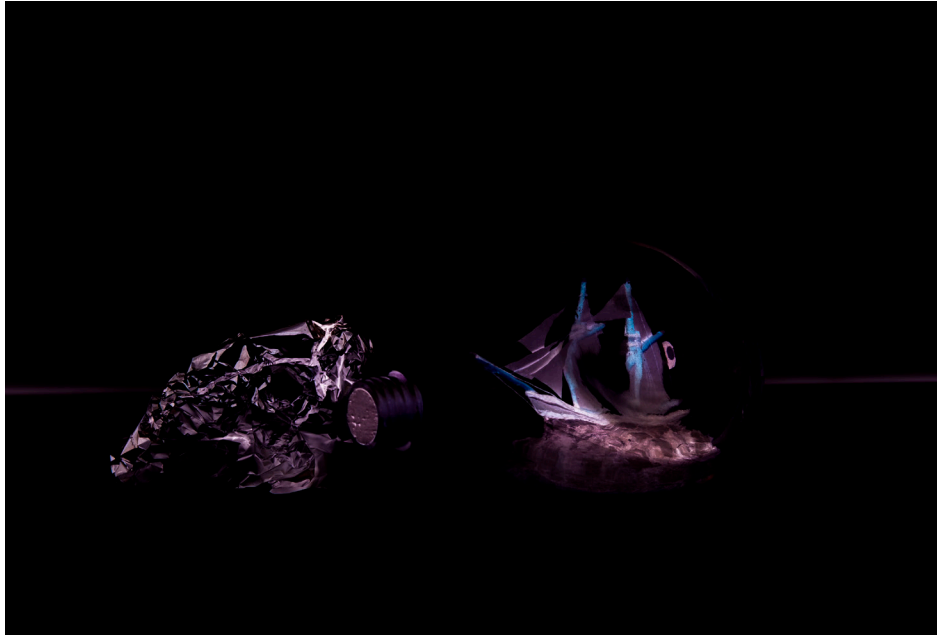
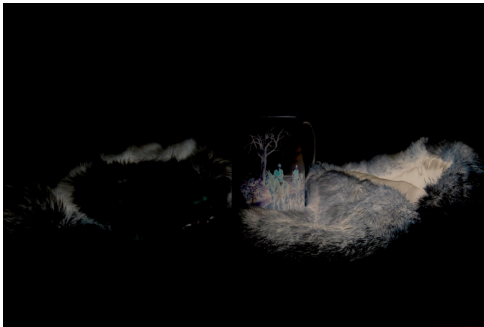

Fig. 5.16 (i-ii): Early studio shots for *Drawing Lines in the Sand* exhibition.



is ‘the true Romantic Thing’, moreso, he suggests, than the peak of Mont Blanc (ibid.). The picturesque neither contains the ‘grand pretensions and death drives of the sublime,’ nor the ‘agonised longing for and enthrallment by the beautiful’ (p.121), for Mitchell the picturesque is totemic—that is to say it remains in the realm of the mundane:

Totems are familiar, everyday items, usually from the natural world, that have been found—singled out—usually by what Durkheim calls “fortuitous circumstances,” and have become foundational for identity. (Mitchell, p.122)

For Chong Kwan the use of foodstuffs is a way of reframing material that is regularly taken for granted in the West. But as Candlin notes, Chong Kwan’s version of *Cockaigne* ‘is more reminiscent of Morrison’s [a common UK supermarket] than the delicatessen at Harrod’s’ (Candlin, 2005, p.44), and whilst titles such as *Avalon* suggest the sublime, the illusion of grandiosity is deliberately unsustainable. Perhaps a more direct nod towards the rustic ruins of the picturesque is to be found in works such as *Paris Remains* (2008), in which architectural remains are carved in orange peel, or *Atlantis* (2009) where they are constructed from empty plastic containers. Like many artists, Chong Kwan gathers too. In *Les Precieuses* (2008) she wanders the streets photographing the discarded remains of foodstuffs: egg shells, an old apple, a tomato stalk. And in some of her most recent works such as *The Pan Hag Walks* (2015), she encourages groups of wandering participants to pick up materials on walks and write down a memory or recipe that derives from the smell of that matter.

Gainsborough’s collections of objects that he found on walks would form the subject of compositions in the studio. The artist Joshua Reynolds remarks that ‘from the fields he brought into his painting-room, stumps of trees, weeds, and animals of various kinds’ (Reynolds, 1965, p.211, see also

Previous:

Fig. 5.18: Studio test shots for *Travelling Landscape-Objects: The Hunt*, 2010.

Overleaf:

Fig. 5.19: *Travelling Landscape-Objects: The Hunt*, 2010. C-type print, 80cm x 55cm.





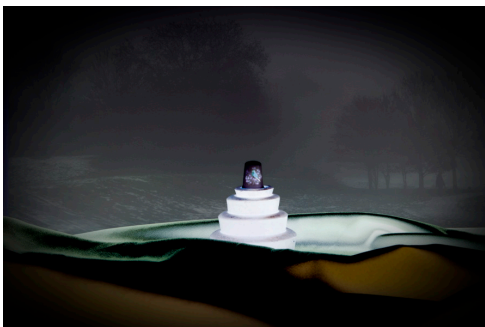
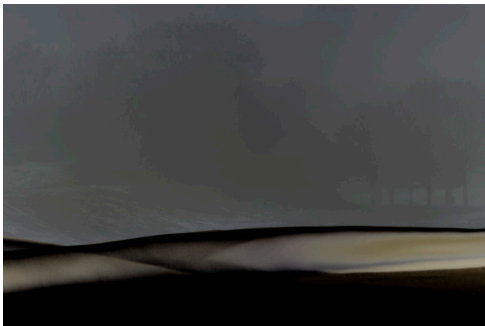
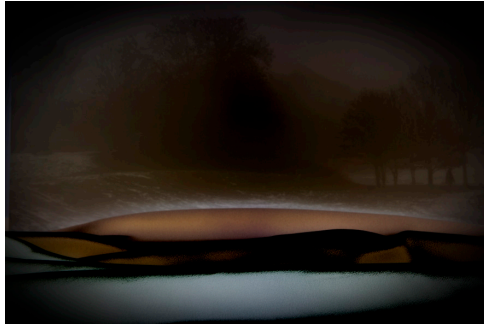
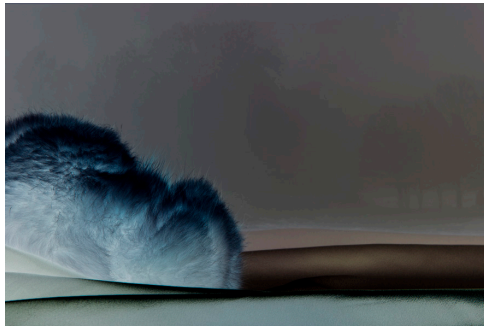
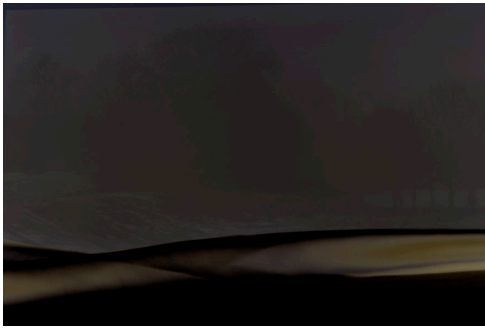

Hayes, 1980), although in the construction of models from broken stones, dried herbs and pieces of looking glass, Reynolds cautions ‘I think upon the whole, unless we constantly refer to real nature, that practice may be more likely to do harm than good’ (p.212). It is a marker, perhaps, of a shift in attitude in nineteenth century landscape painting away from illusionary devices in favour of more rigorous understandings of natural phenomena (Bermingham, 2007; Scrivener, 2011). For Mitchell, however, it is precisely this ‘reframing of the found object within the pictorial’ (2005, p.120) that is central to the picturesque:

What the picturesque wants, we might say, is to raise things up, to elevate them from their abject, supine condition without forgetting where they came from. (Mitchell, 2005, p.120)

In Gainsborough’s show-box, and in the constructions of model landscapes, this ‘raising up’ can be said to have been done through the mediation of light. As Basil Taylor writes:

Of the later pictures it is said he would set up his models in a dark room (“where neither they nor the pictures would be scarcely visible”). Gradually he would let in more light, gradually more and more of the form would be revealed. (Taylor, 1951, p.5)

Likewise, Reynolds reports that ‘we must not forget... to make some remarks on his custom of painting by night’ (Reynolds 1965, p.212), and it was a technique he developed as much in his portraits as his landscapes (Butler, 1992, p.20). In a similar manner, the showbox provided an intensely private, illuminated experience. According to Myrone:

The essentially private nature of the viewers experience is critical. It is a magnifying device, with the movable lens enlarging the image, but also making it appear more distant. Combined with the effects of the candles that originally illuminated the transparency, it thus intensifies the viewer’s perception of the painted landscape.’ (Rosenthal and Myrone, 2002, p.256)

Previous page: Fig. 5.20: Studio test shots for various landscapes

In this illuminated peep-show the effects of a flickering candle would mirror such illusions as a lighted cottage at nightfall, but may also have influenced the scale, and the 'evanescent nuances' (Waterhouse, 1958, p.33) of his later oil paintings, a number of which were tiny.

In Chong Kwan's work there is a similar luminosity that emerges from photographic image series such as *Cockaigne*, or *Veduta Romantica* (2007) (fig. 5.14), here an effect of careful lighting using flash and modelling lights. So too are the dimly lit remains of *Atlantis* (2009), although here the images are far less contained, less private, rising up over two metres. But perhaps in these works too there is an echo of Reynolds observation, that:

By candle-light, not only objects appear more beautiful, but from their being in a greater breadth of light and shadow, as well as having a greater breadth and uniformity of colour, nature appears in a higher style; and even the flesh seems to take a higher and richer tone of colour. (Reynolds, 1965, p.212)

Making Landscapes

I move my studio set up to the cellar, a room that contained a subterranean light, and in which had already begun to gather an assortment of miscellaneous objects that had not found a place upstairs following the move to the new house. Baking utensils, spanners, plastic cups and kitchen foil in the first images (fig. 5.15 i-ii), an attempt to recover the reflective quality of earlier works. Almost immediately these images become darker, not because of the ambient light, shot in negative these images reflect the over-exposure of the light-box. There is a *tending* towards over-illumination as much as towards a gloom that will eventually envelope the objects and contain the scenario. The vignette appears to accentuate this containment. There are objects I now find in the cellar that already contain landscapes, or at least appear to want to be in them. China objects belonging to my wife's late grandmother, a ship-in-a-bottle picked up in a second-hand market. Before long the objects are no longer being 'found' in the cellar but also sought on the high street, in charity shops and second-hand stalls in the local markets. There is an



Fig. 5.21: Untitled, 2010. Inkjet on archival paper. 80cm x 55cm.

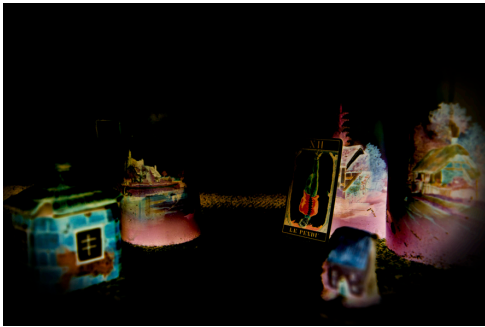

effort to gather materials that have the potential to ‘co-operate’ (Wentworth, 1988, 00:10:38). Along with ceramic objects I begin to take photographs on walks in the surrounding countryside, which will form new collections of images intended for future compositions. They become theatrical backdrops or panoramas in front of which a ‘scene’ will be set out. Between shoots, there are a number of mini-expeditions, although trips to the woods or to a local walking spot are made a little more laborious by the need to take and use a digital SLR camera. Myself and my wife find ourselves framing the landscape, discussing its theatrical or picturesque potential. Or we find ourselves taking days out to local towns, scouring junk shops and markets, questioning each other or admiring each others discoveries. She asks how I plan to use these photographs or knick-knacks, what do I want them to say? I find it hard to answer her directly, since too often they provide suggestions of their own. She will also bring ideas of her own to the things we recover, often in the form of questions along the lines of: ‘What about this guy? He looks like he could be a local character, couldn’t he go with that other object you found?’ Back in the cellar things now accumulate in boxes and on shelves.

One might argue that there is a difference between the objects that I *find* in the cellar, and those I *seek* out in the charity shops on the high street or on second-hand stalls in town centres in North Dorset. Mitchell outlines the received understanding of what makes a found object by providing us with two criteria:

(1) it must be ordinary, unimportant, neglected, and (until its finding) overlooked... and (2) its finding must be accidental, not deliberate or planned. One doesn’t seek the found object, as Picasso famously remarked. One *finds* it. Even better: it finds you, looking back at you like Lacan’s sardine can or Marcel Broodthaers’s *L’oeil* jar. (2005, p.114)

But as Mitchell elaborates, being found is a temporal condition of the object, it is a part of its biography. ‘What’, he asks ‘is *not* the found object? Answer: the *sought* object, the desired object, the sublime or beautiful object... the

Previous page: Fig. 5.22: Studio test shots for *The Hanged Man*.

objects we are looking for, the objects of theory' (p.116). Once plucked from obscurity the object is 'revealed', placed on display, taking on a new 'role'. As Mitchell acknowledges, the display of junk and obsolete technology has become firmly ensconced in the discourses of display that it is almost a genre of contemporary art (p.112). But here I am not interested in extending the argument that junk may constitute a genre of contemporary practice, but in the shifting and dynamic spatialities that are formed by bringing these things into proximity in the processes of creating that visual work, either 'in the field' (so to speak), or in 'the studio'.

Aesthetic geographer Harriet Hawkins develops an understanding of how these forms of gathering and collecting form a kind of place-making through the regular walks and accumulations of photographs made by the artist Richard Wentworth, and in doing so acknowledges the material potentiality of junk as a 'means through which to constitute an understanding of oneself and one's relation to objects' (Hawkins, 2010c, p.21) through the works of a number of artists including Tomoko Takahashi (2010a), Michael Landy (2010c) and Richard Wentworth (2010b). As Hawkins puts it 'slippages between "everyday object," "ethnographic object" and "fine art object," are never clear-cut and stable, but rather are complex and contingent as objects continually circulate' (2010a, p.655). Hawkins draws from the matter-orientated analyses of writers such as Jane Bennett (2001; 2010), Rudi Collredo-Mansfeld (2003), and Caitlin deSilvey (2006), and circulatory discourses around material culture offered by the likes of Daniel Miller (1998; 2005; 2008), Nicky Gregson and Louise Crewe (2003), although she does so with a distinct interest in contemporary visual arts practices.

Of particular interest here is Hawkins's examination of the practices of Richard Wentworth, in she which follows the urban perambulations of the artist as he transverses his 'home territory' around Caledonian Road in North London, recording photographically the incidental arrangements of things and spaces he finds *en route*:

Over the three decades he has lived on the street, affectionately nicknamed 'Cally', Wentworth has taken many thousands of photographs of the area. He frames his home territory through second-hand shops



Fig. 5.23: *Travelling Landscape-Objects: The Hanged Man*, 2010. C-Type print. 80cm x 55cm

and the arrangements of discarded objects he comes across during his day-to-day journeying around the neighbourhood. (Hawkins, 2010b, p.805)

She is largely interested in Wentworth's photographs, but these she positions firmly within his sculptural practices. The photographs, she notes, must be seen as part of his practice as a whole, rather than as individual images, a 'rumination' within a narrative that has developed over thirty years of practice (Hawkins, 2014, p.137). Notwithstanding ongoing projects such as *Making Do and Getting By* (1973-), Wentworth is arguably better known for his sculpture than his photographic work, however Hawkins sees the potential for reassessing the iconic content of his photographs by considering them in relation to his sculptural practice. In an approach to Wentworth's photographic series that parallels the materialist pivots of Edwards and Hart, and della Dora (see also Olin, 2012; Brown and Phu, 2014), Hawkins argues not only for an understanding of Wentworth's photographic practice as inextricably linked to his sculptural work through their object, as much as their iconic qualities, but *also* for one that takes account of the 'framing' of the work in book form, in presentations and in gallery exhibitions:

Just as analysis should attend to the surrounds of landscape images in interpreting their visions of landscape—whether this be in the frames of paintings, the boxes of peepshows, or the tent curtains, and structures of the panorama—so there is a need to attend to the supports and surrounds of Wentworth's images. These are less "frames" in the material sense of wood or metal surrounds, but rather the framings supplied by Wentworth's artist's books and his self-curated exhibitions and talks: a sequence of surrounds that provide both narrative but also material form... to consider Wentworth's images is not just to consider image *qua* image but also to examine the material and practices for, and of, their display. (2014, p.137)

For Hawkins it is by attending to the geographies of production, consumption and circulation, and not only to a final object that we are able to develop an understanding of Wentworth's work that enfolds the agencies of 'people, objects and artworks', (2010b, p.819).

An example of Wentworth's shifting and contingent relation to the objects that are gathered in the studio can be seen in the BBC documentary *Five Sculptors: Richard Wentworth* (1988). Here a young Richard Wentworth explains how his processes for creating works involve ritual visits to particular junk shops in which things are 'reliable for being surprising' (Wentworth, 07:50), and for offering up 'a variety of things [that have been] abandoned and [are now] made available again' (08:15). Back in the studio these objects become animated further. Lining walls, stacked on boxes or surface, covering the floor these things are described as if they enter into conversation, both with each other and with the artist:

I like the gap between things, I like the way that if you look around any space there are things next to other things, which... aren't there by plan... They're just there, and that they have a relationship... What I have in the studio really are things that I think are useful to me... some of them have chosen to prove me wrong, so... they've turned out not to be useful to me and after three or four years are still lying around covered in dust giving me two fingers and saying... they're not going to do it... they're not going to perform... that they're resistant, and other things that I hadn't got very much faith in, which are quietly saying... (y'know) may be they'll co-operate or may be they'll join in some kind of scheme that I have. (Wentworth, 1988, 10:38)

The direction these collaborations take appear not to be predictable, they have another life (15:50), they appear to have the power to shape the performances Wentworth himself enacts within the studio (06:20), and they move beyond the studio, establishing new relations to the world outside (05:30; 15:50). These co-operative *found* things that eventually make it to and through Wentworth's studio do not go unchanged. They take new forms,

Images on following pages:

Page 194. Fig. 5.24: . Studio test shots of various bought and found objects.

Page 195. Fig. 5.25: . Studio test shots for *Dawn Chorus*, 2011.

Page 196. Fig. 5.26: *Travelling Landscape-Objects: Dawn Chorus*, 2011. C-type print. 80cm x 55cm.

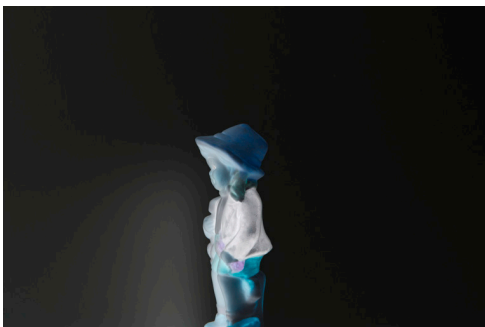
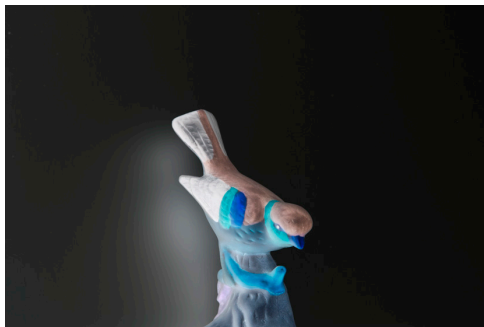
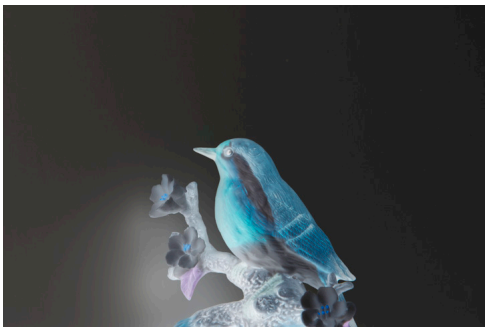

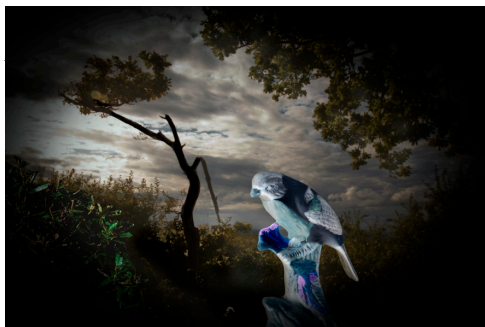
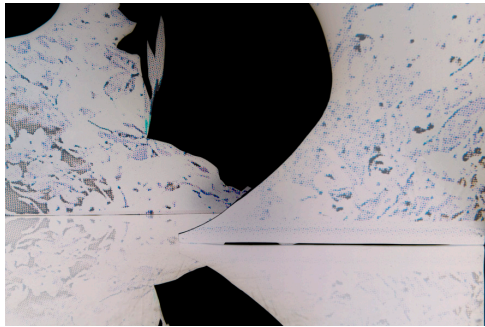







Fig. 5.27: *Travelling Landscape-Objects: The Old Colonial*, 2011. C-Type print. 80cm x 55cm.



Fig. 5.28: *Travelling Landscape-Objects: Woodsman*, 2011. C-Type print. 80cm x 55cm.



Fig. 5.29: *Travelling Landscape-Objects: Motherless Foal*, 2011. C-Type print. 80cm x 55cm.



Fig. 5.30: *Travelling Landscape-Objects: The Chase*. 2011. C-Type print. 80cm x 55cm.

they even encourage different things to be reformed and deformed in their own image, such as the forming of galvanised steel ducting into the shape of upturned houses. They become idealised, like the house and ladder. They become new assemblages, as in the house-vest-ducting (15:10) that becomes *Other Geologies* (1988). ‘What emerges is a “rubbish” aesthetics’, says Hawkins ‘that privileges material fluidity and circulation over fixity’ (2010b, p.805).

The walls of my studio are not adorned with the galvanised or utilitarian objects in the possession of the young Richard Wentworth, nor with the images of informal sculptures on urban streets. They are lined with decorative ‘tat’, largely carrying picturesque images of the British countryside, and a growing collection of photographed fields and woodland. But, like della Dora’s scenic paperweights and snow globes, the kitsch images of landscapes or cottages printed on the sides of the ceramic tankards and trinket pots are more than simply ‘static, bi-dimensional’ visual texts to be decoded (2009b, p.334), they possess a three-dimensionality; a physicality that extends beyond the ‘non-physical relationship of signification’, and demands an acknowledgement of their ‘more-than-textual, more-than-human qualities’, and their ‘own agency’ (p.340). They may have been the marvelled at, (or more frequently sneered at), ‘collectibles’ and knick-knacks that have passed from a state of domestic exhalation and display (della Dora, 2009b; Ramsay, 2009; Peters, 2011) through the disposal practices of good housekeeping to the transformation and redistribution processes of second-hand collecting (Gregson and Crewe, 2003). Now they are co-opted in to new assemblages, new geographic imaginings, no more or less ‘authentic’ than the images that travel on the objects themselves:

Landscape-objects are also central to the construction of geographical imaginations about places from which we are entirely disconnected... places we have never visited and probably never will; places that perhaps do not even exist (like Poussin’s mythological landscapes). (della Dora, 2009b, p.345)

As della Dora describes, as landscape-objects travel they may change their

function and meaning: images cut from textbooks for framing or, in my case, objects garnered from charity shops that might once have stood on mantelpieces, reassembled in dioramas to be reproduced photographically for a series of artworks. These objects are not just re-employed as a means to critique particular representations of landscape that persist in the reproduction a version of British rurality, but to join in the unfolding of new narratives, in which '[b]iographies of inanimate things constantly intertwine with human biographies generating new meanings' (p.348). Objects like these are known to me—they adorned the walls and mantels of some of the more elderly family members. Some carried images of soft-edged hollows in which cottages or reclining couples nestled, or bare-footed figures of farm labourers lost in thought on ceramic hillocks—icons of an idealised agrarian nationhood (Matless, 1998; Mitchell, 2002, see also Tolia-Kelly, 2008). The collection of ceramic dishes and tankards, glass bottles and carved wooden I begin to amass returns me to some of these objects. Indeed, some are objects that we already have in our possession, handed down as keepsakes following the death of an elderly relative. The images they carry want to extend beyond the limits of the china surface, to be taken up in new narratives, created from the potential of the object to take part in the telling of its own history, and for that to become joined in the stories of my own past. The proximity of objects to one another generate new tensions on the shelves that line the cellar, which then play out new orchestrations as they become enmeshed in the performances on the light-box.

Beyond the cellar, and on the walks that extend out from the house to the town, to the surrounding fields and woodlands I also gather photographs. These start out as a means to anchor the compositions into an image that makes a direct reference to *a* place, rather than have them floating in an indeterminate cosmos. These walks were not the epic expeditions of land artists or psychogeographers such as Richard Long, Hamish Fulton or even Iain Sinclair; often they were part of a dog walking ritual that would take place on the nearby fields at the edges of Blandford, or in local woodland. They were, perhaps, closer to the 'repetitive crossings' and 'daily circuits' that Hawkins identifies in Wentworth's outings (2010b, p.809). But if the intention

was to create a more direct link to a site outside the studio, the photographic images that began to appear behind the arrangements of objects often described a similarly idealised and abstracted version that now mirrored many of pictures on the objects themselves. The photographs I took were already implicated in the studio dioramas, they were not found so much as sought. Sought for what they might afford as material in a set. As much as the backgrounds were becoming landscaped, the landscapes I framed were moving towards backgrounds—identified for their lack of any real discernible points of interest. As they were framed in the window of the viewfinder they were formed part of a movement that oscillated between the low-lit cell of the basement in which these dioramas took shape, and the cracked-glaze surfaces of pottery objects bearing picturesque vignетted scenes.

Digital photographs of local fields and woodlands became negative images, then prints, prints onto boards, boards into backgrounds. Foregrounds formed in ‘found’ fabrics, sometimes over boxes or other props employed to raise surfaces. By the time the objects began to evolve into new arrangements, the images they bore on their surfaces or in the forms they took had already resonated with a series of other artefacts—had already transformed both the photographic backgrounds and the encapsulated landscapes. The arrangements too were now being transformed, back into digital photographs stored first on a memory card then on a hard drive, copied to an editing program, then out to print or attached to an email. Each of these actions moved or altered the photographic image into a form that was either more detailed, more refined, or more ‘portable’. Over 300 different versions exist of one of these images, each marking a stage in the evolving pattern of production, each fulfilling a different function: thumbnails, previews, test-print images, versions for email or for websites, versions for publicity posters or flyers, ‘final’ versions for the printers.

The photographs that multiplied and proliferated on the cards, drives and servers, set in motion new material flows. However, these apparently dematerialised ‘objects’ lack the smell, the patina—the physicality—that might be ascribed to other kinds of travelling objects such as postcards, photographic prints, tea towels and illustrated souvenirs. They are called to

life from the black-boxed interiors of our personal hardware, flashed up on back-lit flat screens. We can replicate and activate them time and time again and they appear never to change. Della Dora briefly alludes to this in the concluding paragraphs of her examination of travelling-landscape objects:

Like every year, in April 2007 I became a 'raree-showman' and travelled to San Francisco to disclose my digital 'cabinet of curiosities' at the annual AAG meeting... One of the questions that kept teasing me as I was preparing the presentation was: and how about digital images and slides?... Were the landscape images I was about to show my audience also travelling landscape-objects? Did they have the same material agency as the plastic fan, pen, old atlas or postcards I had brought along and was going to invite my audience to handle? (Della Dora, 2009b, p.351)

She answers this question by drawing attention not just to the images themselves, but, by way of their occasional fallibility, to the assemblage of boxes, lights, screens and other networked or meshworked technologies that provide us with that flickering light: 'I had to physically interact with the projector rather brutally, banging it every now and then', she confides (p.351). Jonas Larsen (2014) takes up exactly this question concerning the digital image that della Dora poses in order to examine the capture, transmission and distribution of digital tourist photographs. Larsen suggests that whilst '[a]nalogue tourist snaps were destined for a long life as material objects' (p.29), the practice of taking analogue photos was also one of deferral in which, for some time tourist snaps would begin an invisible life as a negative contained within a light-tight box, and that 'their real social lives first began as prints once tourists had returned home, delivered them by hand to the chemist and later picked them up' (p.30). Following Mike Crang's appeal to think about the practices involved in taking photographs as much as the resulting images (Crang, 1999) Larsen describes the differing performances of amateur photographers as they use analogue and digital technologies for recording photographic images. Because of the limited number and the relative cost of each photograph, when taking analogue photographs, he observes, photographers take time over composing and choreographing the

Overleaf: Fig. 5.31: *Travelling Landscape-Objects: Young Lovers*. 2011. C-Type print. 80cm x 55cm.



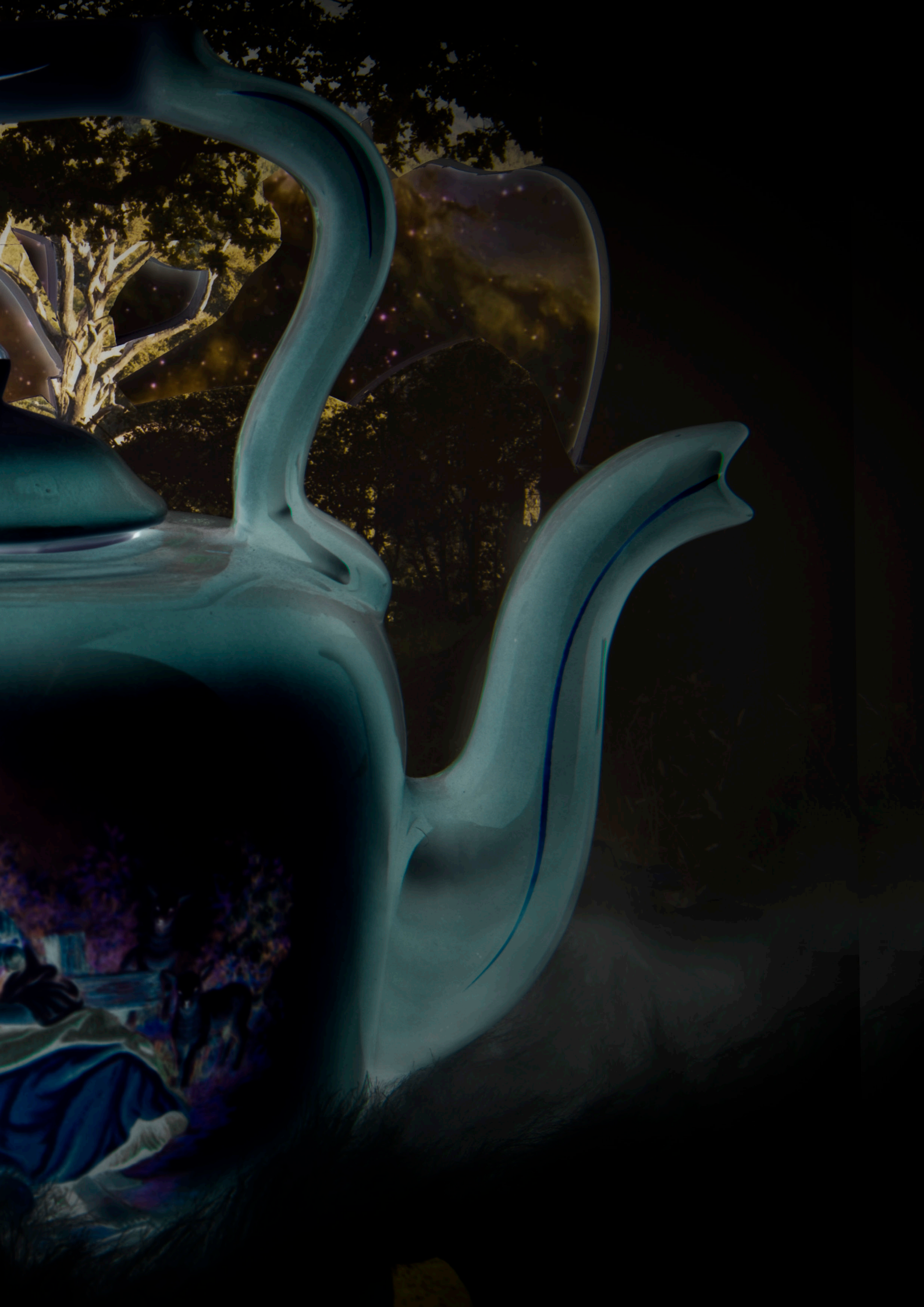

image (p.30). Digital photography, on the other hand, offers the freedom to ‘shoot around’ (p.32). But this freedom means that more time is also spent immediately viewing and deleting unwanted images, before recomposing and reshooting, and “images’ that do not charm at first glance on the digital screen can be erased and re-taken at no extra financial cost’ (Larsen, 2008, p.148). In examining the role of digital photography within the family, Gillian Rose argues that ‘digital family photography has not *altered* family photography, but rather *intensified* it’ (Rose, 2014, p.79), not only because of the greater number of images taken, but also because of the greater capacity for organisation and sharing. This *intensification* is similarly hinted at in Larsen’s observations that, through travel blogs and social media we create a feeling of actively ‘travelling with’ our friends and family (Larsen, 2014, p.38). And whilst authors such as John Tomlinson (2007) emphasise the ubiquitous, instantaneous and ephemeral nature of these images as evidence of ongoing experiences, Larsen (p.41) argues that the fact that these images are archived, rather than instantly deleted on social media sites such as Facebook and Flickr, points to a belief in their continuing value.

Whilst the orchestrated set up in the studio might suggest forms of photographic practicing that is a world away from the instantaneous snapshots of tourist photography, the images I am creating participate equally in these paths of distribution. A progression of half-completed works and final ‘versions’ are selectively distributed by email, through file sharing services, on websites and through physical print outs that use various different printing technologies. They are sent to the curator, to my peers, to my research supervisors, to interested family members, to the printers and to the companies producing the marketing materials. Some of these seem to echo the invitation to ‘travel with’ that Larsen sees in shared digital tourist photography, by engaging others in a continually unfolding series of photographic events. And in post-production software and internal file systems images are labelled, rated, tagged, filtered and added to various collections: ‘Tethered Images’, ‘LR Captures’, ‘CTtests’, ‘Finals’, ‘Small Finals’, ‘Finals DNG’, ‘email_imgs’. As they are created and recreated their titles also shift: ‘Teatowel Islands-2.tif’, ‘CT Island 30162.jpg’, ‘Portland Bill 3.jpg’, each coalescing into one

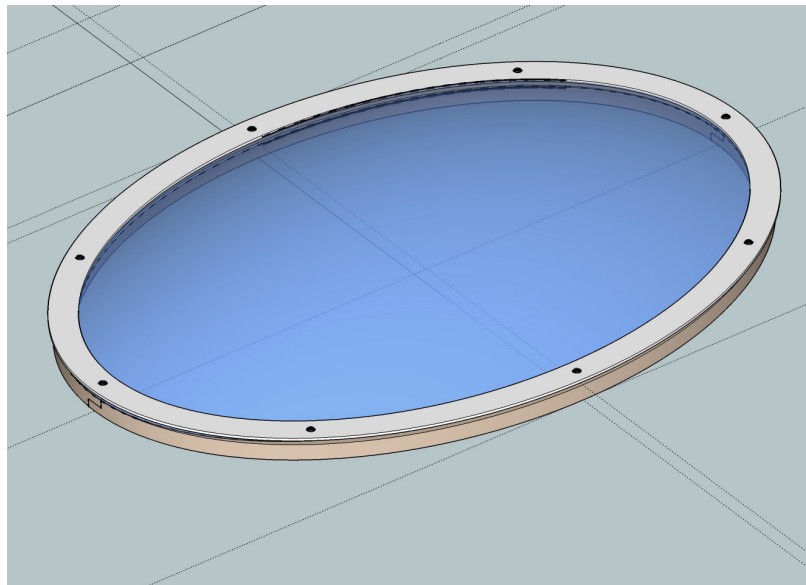
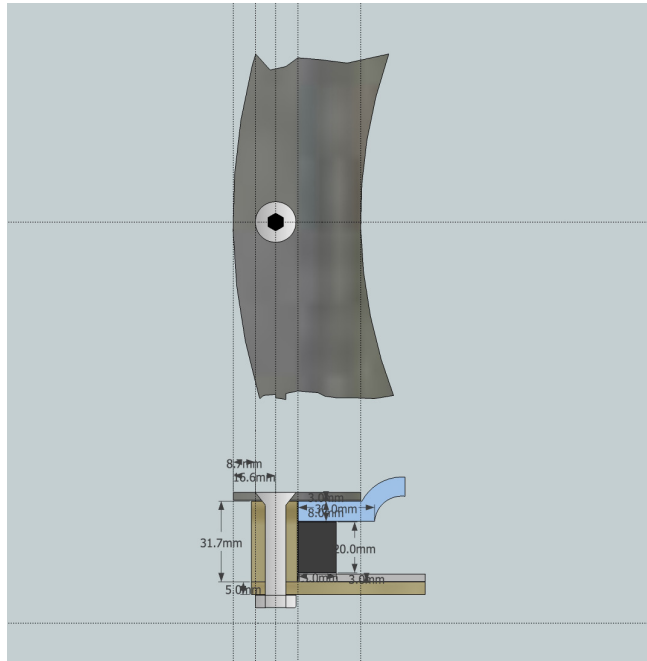

Fig. 5.32 (i-ii): CAD Models for frames.

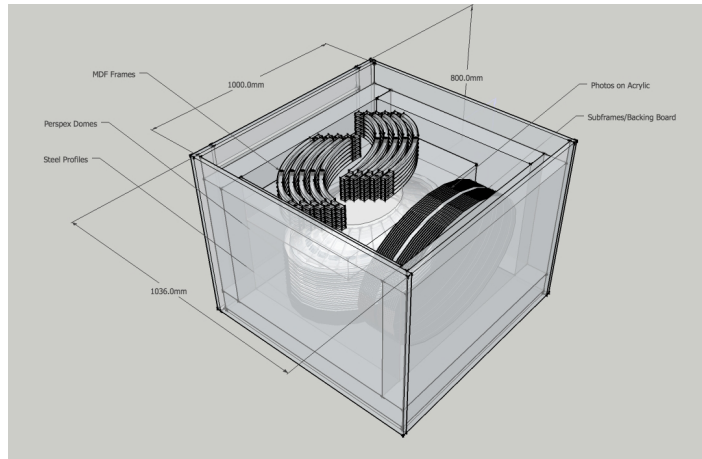

Fig. 5.33: Packing instructions

constellation of objects and ideas or another. Yet whilst these often remain in code-form, hidden away in the various drives of desktop computers, laptops, memory cards or servers, ready to be recompiled in image-form on the screen or printer they are no less ‘material’. Indeed not only does their very existence relies on the their capacity to be contained within up-to-date systems from which they can be recovered, (cf. Baker et al. 2005), their coded presence also takes up physical space—the black-boxed drives and portable disks, or server ‘space’. Each time they are decompressed and brought to the screen they are transformed. But more than this, as Hawkins remarks with Wentworth’s photographic images (2014, p.137), and della Dora notes in her battles with her ‘moody metal box’ (2009b, p.351), images are dependent on the supports in or on which they travel, and on the ‘framings’ supplied by the practices of display:

An original view of Venice by Tintoretto, for example, is not the same as a poster reproduction or exhibit brochure. A poster or brochure reproduction is not the same as a reproduction on a bag or on a silk tie, and a reproduction on a silk tie is not the same as one on a cotton T-shirt, plastic dish or cheap tourist fan. (della Dora, 2009b, p.349)

So, to Hawkins list of potential framings: the paintings, the peepshow boxes,



Fig. 5.34: Unpacking and inspecting works in Sydney. Images © Virginia Lee

the tents and structures of travelling panoramas, the book pages, I would add della Dora's projector, my laptop screen and desktop monitor, and perhaps those physical boxes which enable the storage and transformation of digital files required for the illuminated pictures that travel apparently effortlessly between myself and the curator, Claire Taylor.

Boxing Landscapes

Whilst the digital images crossed international borders almost instantaneously, it was far more complicated and far more laborious to get the physical printed images from the studio to the site of exhibition in Australia, and maintain or protect them from the environment for at least as long as the show was on. Creating frames and boxing the images within them proved to be as elaborate a project as producing the works themselves, and from an early stage in the discussions between myself, Taylor and a number of shipping companies, we were discussing the potential problems we might face in relation to crating, shipping or freighting, Australian import restrictions and permits, environmental conditions and the final installation. The borders and check-points that regulated the types of freight and the material that this freight is constructed from, also moderated the temporalities of movement (Sheller, 2011, p.4, see also Sheller and Urry, 2005). They shaped both the

speed and direction of travel, but also the composition of materials.

Even before many of the final photographic works had been produced, the constructions of the frames that would support them in their journey to and from Sydney were already being designed and fabricated. CAD designs that initially sketched out the rough forms that each object might take grew gradually more complex as material costings, fixings and environmental

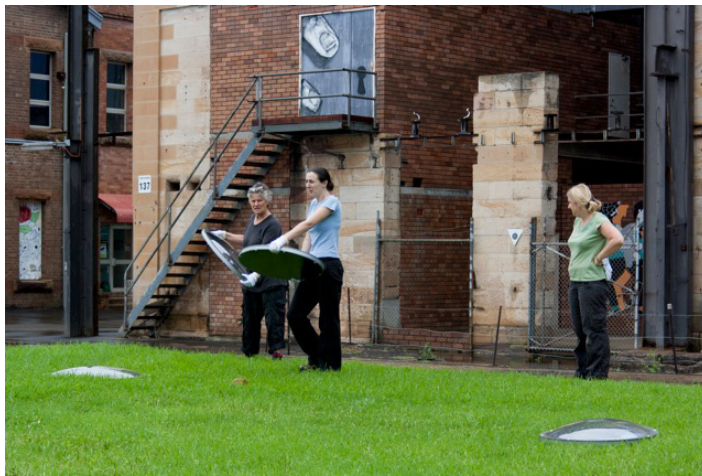

Fig. 5.35 (i-ii): Installing work for *Drawing Lines in the Sand*, 2012.
Images © Kate Scott



Fig. 5.36 (i-iv): Installation photographs for *Drawing Lines in the Sand*, 2012.

Images © Kate Scott

factors (such as protection from moisture and sunlight) began to impress on the digital structures being modelled. Mistakes made in early prototypes, for example the manufacture of rolled steel frames, often led to costly adjustments and occasionally the complete redesign of the frames and new wooden constructions needed to be carefully planned. They needed to be able to both withstand the moist atmosphere of being dug into the soil, capable of being shaped through manufacturing processes (such as CNC routing), and able to pass through the Australian import restrictions on timber artefacts. Moisture absorbent materials for double glazing units, watertight silicone seals, molded 10mm perspex that would resist being stepped on, all formed part of a construction that included routed, sealed and finished exterior MDF, laser-cut steel, plastic mounted images and ground fixings. Boxing or packing the images not only required particular kinds of materials and structures for containment in order to be transported, but also to be enabled to pass *through* borders. As Hilary Cunningham and Josiah Heyman note '[e]nclosures and mobilities... join at borders, in the multifarious processes of entering, avoiding, detecting, classifying, inspecting, interdicting, facilitating, and revaluing that are borders of everyday routine' (2004, p.295).

In *Taking Sacred Space out of Place* (2009a), della Dora also follows the packing and shipping routines that accompany the transportation of icons from the Saint Catherine monastery in the Sinai peninsular to the J. Paul Getty Museum in Los Angeles. Transporting these icons involves complex fabricated structures that not only preserve the artefacts themselves, but also preserve the climate of origin:

The problem Getty conservators had to face was that having adapted to such a dry climate over the centuries, the icons were especially sensitive to changes in humidity. 'At home' inside the monastery, this rarely exceeds 30%, but in Los Angeles, although located on the edge of a desert, the average humidity oscillates between 65% and 79%. Because of this extreme change, unprecedented measures and precautions had to be taken in order to keep the objects in a stable microclimatic environment during their long transoceanic journey and their permanence at the Getty Center for the exhibition. (p.234)

These complicated assemblages that form the crates for transportation are composed, we are told, of ‘25 layers of materials, carefully devised by conservators to provide maximum protection during the objects’ journey’ (ibid.), and contained not only the artefacts, but also the microclimate of the desert and a small laboratory of instruments for measuring humidity, temperature etc. Also travelling at different speeds, and at various stages converging with the artefacts, were the publicity materials, permits, press releases, and condition reports (p.235, see also Latour, 1999).

The budget for *Drawing Lines in the Sand* (2012) may not have stretched to that of *Holy Image, Hallowed Ground: Icons from Sinai* (2007), but in much the same way, crates, frames and documents enable particular temporalities of movement through global mobilities systems (Sheller, 2011). But the processes that led to the creation of the final acrylic domes were not simply directed towards greater protection from either the turbulence of travel or the extremes of climate in south east Australia. The frames were intended to perform a sculptural function too, an acknowledgement, in part, of both the optical technologies employed by European landscape artists of the eighteenth and nineteenth centuries (see Gainsborough’s Showbox), and a motion towards the telescoping of worlds that seemed somehow appropriate in the relationships of distance that were enacted in the travelling objects and landscapes. This was as much an idea of landscape that travels with the object through the layering of particular materials alongside their constructed technologies for viewing. Towards the final stages of making, conversations between myself and the curator turned towards the establishment of particular landscape conventions through the technologies of ‘seeing’ that arrived with early European settlers in Australia. Historian Ken Taylor draws attention to the idea that early images of Australia created by European settlers borrowed heavily on a tradition of picturesque idealism inspired by painters such as Claude Lorraine (Taylor, p.3). Taylor uses the nineteenth century convict artist Joseph Lycett as an example of how the Australian landscape was made more inviting to potential British colonists:

Lycett’s aquatints, published in England after he won his reprieve,

clothed the landscape in greens that were lightened from his original watercolours with their Australian brown hues, presumably to attract would-be colonists. Accompanying texts to the scenes were seductive, whilst many of them reflected the aura of an extensive landscape park or garden. (p.4).

WJT Mitchell also describes the connection between imperial expansion and the assimilation of a European idea of landscape, although he sees a far greater tension in the depiction of Australia, particularly by English painters. Drawing on the work of Bernard Smith, Mitchell extends an account of the representation of Pacific Islands such as Tahiti, which, according to Smith, were often represented in the style of Claude Lorrain, whereas pictures of the New Zealand landscape were modelled on the romantic wilderness of Salvator Rosa (Mitchell, 2002, p.18). He goes on to note that early European, or perhaps more specifically English, representations of the Australian landscape suggested a rather a different problem. Its depiction depended on how England wanted to portray this land, ‘because of the ambivalence in... what it wanted to see there — a fearsome, desolate prison for transported convicts, or an attractive pastoral prospect for colonial settlers’ (ibid, p.19). Nevertheless, in both these accounts the idea of landscape is bound up with the materials they travel on pictorial images to be hung on the walls of settlers houses, reminders of ‘home’ lands. Similarly, images that travel back from Australia bring with them hybrid landscapes, verdant and desolate, moving with different travellers, touring their own visions of place on stretched canvases and printed sheets. In fact in both these accounts very little attention is given to the particular materials used in the production and circulation of these images—notably aquatint and watercolour—and the technology of European vision, linear perspective. A form that required a particular orientation of the body towards display.

In the work that was being prepared for *Drawing Lines in the Sand*, the constructions that supported and preserved the image from the destructiveness of travel also anticipated the final framing the images, and the bodies viewing those images, in display. They asked for particular orientations, they expect particular behaviours, and although the images were created with the same

linear perspective of European landscape painting, the choice to embed them in the ground was a deliberate subversion of this upright viewing position, one that was intended to reflect the notion of ‘the other side of the world’. There was an expectation was that the viewer might stand above the clear dome looking into the image, but added to the construction were certain mitigations against the possibility that the domes themselves might appear to invite the audience to step on them. So, ahead of the domes containing the images went instructions on how the potential audience might avoid destroying the works by not standing on them, along with annotations about the way the audience might ‘engage’ with the works by considering them in relation to the conventions of European landscape, or in relation to the depictions of far off places carried on the sides of souvenirs or in paper weights. With the domes went a small collection of installation instructions, viewing instructions, supporting statements, titles that not only attempted to orientate images and objects, but bodies too.

Despite all attempts to create a protective structure that would retain its integrity through the ordeals of travel, the works would return irreparably altered. Super-heated by the sun, cooled by cloudless nights, the glues binding the images to their backing boards failed. The moisture absorbent materials could not cope with the condensation and the intensity of the sun bleached the images. What returned was transformed by the events of travel, shaped by environmental conditions. It was the imposition of the artworks own materiality (della Dora, 2007, p.300) that finally ‘did for’ the pristine hemispheres that went out to Australia. But through that, they came back fundamentally changed the physical effect of the continent in their muted and blistered photographic surfaces. These works had been altered, but in that degeneration I began to see something of Cockatoo Island, and that part of Australia, that exceeded the images on tea towels that returned with my grandmother. As an artefact in the studio, or in the workshops in which I carefully laser-cut and assembled the pristine photographs into their frames, there was a belief in their permanence. The construction of airtight frames, like ‘pods’, in which a band of moisture retardant fabric was designed to

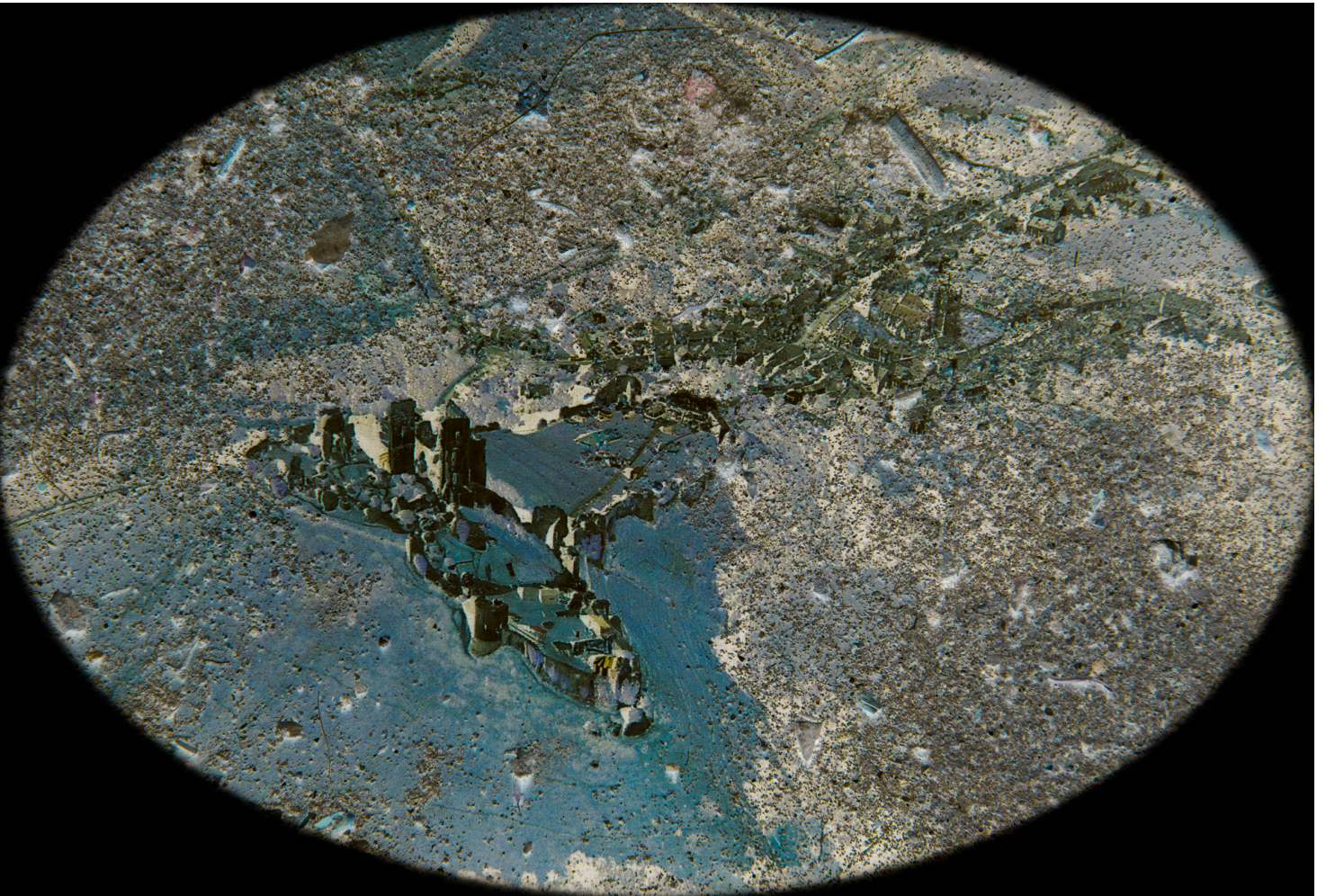

Fig. 5.37: *Untitled*, from the series *Dust*, 2011. Inkjet on archival paper. 80cm x 55cm.

mitigate the effects of changing temperatures, was intended to preserve the works. Colloredo-Mansfeld points to the ‘curiously immovable’ presumption that ‘social significance (albeit a living, mutable one)’ is tied up with ‘physical permanence’ (2003, p.246), and certainly the value I, (and I imagine the curator), attributed to these objects as artworks was connected to their durability. So the returning objects brought a new understanding, not just of power of the Australian sun, (I had already gained a sense of that in Barbara Bolt’s account of painting in the Kalgoorlie desert (Bolt, 2004, p.131), but of the shifting status of the work. In this transition from significant object to mutable matter geographer Caitlin DeSilvey reminds of ‘the artefact’s status as a temporary arrangement of matter, always on its way to being something else.’ (2006, p.334). The works that had been dug into the soil at the start of the exhibition, and which had some allusion to telescope lenses had lost their optical quality towards the end, and like much of the site itself, begun a process of decay similar to those panoramas that, after many years of travel and exposure to the elements ceased to provide the illusion they were created for (della Dora, 2007, p.300). But DeSilvey also reminds us that ‘decay reveals itself not (only) as erasure but as a process that can be generative of a different kind of knowledge’ (2006, p.323), and in this case the understandings that these objects brought through the process of deterioration would be that which began to inform this writing, and would provide an influential agency in future reflections on a series of works entitled *Dust* (2011-2012).

As the reference to *Dust* (fig. 5.37) suggests, whilst this chapter may draw to a close three ‘movements’ but there were already activities in motion that would begin to take new forms, move in new trajectories, exert new forces, and that also drew up the matter, thoughts and actions of previous events. In truth some of these had already started, since *Dust* began as an alternative to the works I would eventually show for *Drawing Lines in the Sand*, a body of images that returned to the postcard images of earlier works, and matter from the ‘studio’ floor, in this case the dust and detritus that had gathered in corners during the creation of other works. Except for here, in a form of epilogue to the last body of work, these works remain just outside the horizon

of this thesis, but I include them here as a way of illustrating that sense of flux that underpins much of this text. In this chapter this sense of change has been explored by turning from the ‘visual-material *doings*’ (Kontturi, 2012, p.42, my emphasis) of the studio in Chapter 4, to the circulatory passages of material that move from spaces of production to sites of consumption. I have provided an illustration of various attempts to *represent* practices of exchange by drawing on the iconography of the souvenir, but I have also shown how fragile these representations are by demonstrating the unpredictability of the studio, and the constant shifting relations between matter, ideas and actions. The flow of images on memory cards, USB drives, in email attachments, multiplied and proliferated half-completed works, landscape panoramas, test shots also acted on the forming of new arrangements, performances and images. This chapter has also threaded together a number of theoretical and art historical discourses that bring an object-orientated emphasis to landscape iconography, and to the creation and transportation of these artefacts. I conclude with a reflection on the extent to which these objects become complex assemblies of materials that frame, pack, protect, and preserve a sense of object integrity. In the process I have alluded to the ways in which these transformed the artefacts that went out to Australia by enmeshing them in new material constructions (for example through crating, freighting, importation, and display), and through such careful monitoring might be said to ‘acquire a “socially produced durability”’ (DeSilvey, 2006, p.326)—a temporary arresting of their gradual progress towards deterioration, which, in the end, drew attention to this transformation in very direct ways.



6. CONCLUSION

Conclusion

Nadir

Three months into the production of work for *Borderlands*, in late March 2008, I hired a van and, along with my wife, drove a selection of our domestic furniture to a photography studio at the Arts University Bournemouth where I worked. The objects had been selected on the basis of what turned out to be a peculiarly accurate drawing (fig. 2.3) of the final photographic composition. Underneath this drawing was the list of the objects to be included, or at least considered for inclusion:

VAN	CAR
Chest of Drawers	* Dog bed
Bureau desk	Wellies
Cube cupboard	Mirror
Trunk	Washing basket
Bedside Cabinet	Extension
Tub Chair	* Socks
(Fridge from work)	* Lamps
Shelves	Plants
Metal Shelves	Islands (in box + white card)
Ladders	* Coat hangers on back of door
Maiden	* Papers
Desk Chair	* Artwork: Framed
	* Portfolios
	* Boats
	Islands
	* Big books
	Tracing in a roll (Anne's handwriting)
	Ironing board (Anne's handwriting)

(Personal Notebooks, 2008)

Alongside this list, tucked into the pages of the sketchbook, is a photograph

and accompanying article taken from the Review section of the Guardian newspaper, dated 15th March, 2008. It is a piece on writers' rooms, in this case the writer being Charlotte Mendelson, (Mendelson, 2008, p.3).

When I found this again, I was searching through my notebooks in the hope of discovering small snippets of thinking for a period of practice where I had struggled to write anything about the work I was making. I had remembered the drawing, and I had remembered cutting out the article. I had remembered how the photograph and the article impressed a feeling of the dynamism of matter, thrust up against the window, spilling out across the floor. On the following page I have written "Rodney Graham's Brothers Grimm", a reference to a series of five works by the Canadian artist Rodney Graham entitled *Interiors: The Berlin Studies of Jacob and Wilhelm, Grimm* (1993).

These scribbles and cuttings appear to show an intersection of references that are not neatly directed towards a particular set of intentions. The pencil drawing, which marks out an unusually accurate description of the eventual photograph, seems to have stirred in me a half-remembered image of Rodney Graham's work. Somewhere between the two I must have found, by chance, the image of a room in a newspaper. Perhaps they shared a sense of working chaos, or even stillness, or it could be a feeling of isolation, even amongst the papers, the ceramics, the books and the household objects? I am tentative here precisely because I don't remember why these collected references were important and yet they clearly presented themselves in the gathering up of images and materials that would later form the agglomeration of furniture and personal belongings that I called *Nadir* (2008).

Nadir (fig. 6.1) was created for the Borderlands show. Like most of the other works, it took the form of an island of sorts. When I look back at this work I wonder if this is how I envisioned research at the time. In the centre of the image there is a writing desk that I borrowed to furnish our house. It supported a light-box in the office-studio where the works for Borderlands were produced. Around it are arranged various other bits of furniture: an old TV, shelves containing box files of journal articles, a bookshelf, a clothes maiden, a chest of drawers, some artworks and various household plants. It's not that I fail to remember making the work, but the movements that took



Fig. 6.1: *Nadir* 2008. Perspex-reverse photographic print.

me to this particular outcome seem caught up in the various returns I have made to the small islands works as the processes of writing and editing have smoothed paths between the text and the events of practice, but when I look back on this island of furniture it looks like a very singular and isolated place. And yet, there in the pages of a sketchbook are the signs of a very different experience, a lively and dynamic co-production: planning, gathering, packing, transporting, and assembling, which is also borne out in the countless studio test shots. But perhaps in this respect the image that becomes titled Nadir is not a failure to capture these vitalities, but one of a number of expressions of movement, part of a continuum of open-ended potential paths that are not readily drawn back into one representational image.

Initially I began this research with the question “can strategies of creative production be devised that engage the viewer in reflecting on the relationship between space and place?”, but as I have shown, the study progressed the question increasingly turned towards the way in which these practice-led investigations began to open out new perspectives on the micro-geographic environment of the studio—a space that seemed increasingly mobile and porous. The narration of these peregrinations describes how a number of new questions began to form around the dynamics of these spaces—the assemblages whose sense of singularity (deLanda, 2006, p.29) appeared to emerge from the contingent connections between humans, objects, architecture and artworks, rather than from any privileged or authorial ordering. In doing so I have shown how these concerns led a series of explorations into how practice-led enquiry might offer different ways of reflecting on a dynamic, occurrent understanding of space. And how by turning to the performative aspects of spatial (and artistic) production has helped to form new approaches to thinking about the precarious conditions of subject and object, the ontogenic capacities of artwork or the limits and porosity of the studio. These peregrinations were largely narrated in a chronological manner as a means of emphasising these shifting positions in regard to the aims of the research, so in setting out a context for this research in Chapter 2 I explained that the spaces of creative practice, as much as they seemed to be concerned with forming objects (or strategies), were subject-

Conclusion

forming. 'Space', as Massey described it, 'does not exist prior to identities/entities and their relations' (Massey, 2005, p10). These intersected with notions of a reflexive 'subject', seen as offering greater self-critical understandings in autoethnographic accounts of practice. Here Knorr Cetina and Thrift offered ways of thinking about reflexive consciousness that acknowledged the unpredictability of practice and the inconstancy of subject-positions, and I set out a more 'storied' framework for the study that emphasised a dynamic link between the acts of writing and practice by picking up the threads of past events in the process of generating new ones. This provided the grounds for describing the research in terms of three 'movements', each of which contained within it a public exhibition. Whilst these were not separate 'projects' with discrete beginnings and endings, they allowed for a flow of dialogue to grow from those initial excursions with a hand-held GPS unit, a sketchbook and a collection of drawing implements towards more elaborate orchestrations of persons and materials.

The three movements often unfolded around changes in situation or approach. In the first instance creative activities were directed around different locations: in the development of artistic 'strategies', or later in the site-orientated imperatives of a curated 'intervention' at the Russell-Cotes Museum and Gallery, and later still in the sketchbooks taken on holiday to Switzerland. This section gradually problematised phenomenological approaches that forefront subject-orientated experiences, by contesting the notion that subjects-doing-the-perceiving and objects-being-perceived were separate and opposing points of an empirical axis. So Chapter 3 prompted questions around the performance of drawing and how this reconfigured subject-object relationships through drawings made 'in-the-field'. Since early approaches had been tempered by the counter-cartographic practices of contemporary artists who framed the apparent objectivity of official maps in terms of the hidden power structures they might be said to represent, this chapter also examined the representational capacity of maps in relation to developments in critical cartography. The acts of creating and assembling maps of journeys had already begun to generate observations on the way I orchestrated an arrangement of limbs and drawing materials, and later

how the images resulting from these excursions became taken up in new configurations. But in bringing these performative aspects of drawing together with arguments in critical cartography that reconsidered mapping as a *practice*, and maps as continually emerging through events, rather than as static representations. In doing so I also challenge the all too simple opposition between cartography as an uncritical representation of scientific ‘objectivity’ and art-mapping as an authentic representation of subjective spatial experience. The destabilising of the idea of maps as representations was also used as a means of revisiting the drawings I had been making—a way of interrogating their status as representational objects. In the works produced for *Meeting Place* and in Switzerland there was a gradual move towards the performance of practice, which moves from a sense of drawing as a form of witnessing events unfolding, to a sense of being deeply enmeshed in surges of action and anticipation, of being both in and of the world. This conception still placed me at the centre of activities, albeit in a way that was less removed from the immediacy of experience than my attempts to interpret the jottings of earlier experiments. But as I continued to produce a number of sketchbooks whilst walking, an increasingly pressing concern was how the acts of drawing and walking were forming me into different arrangements, impacting on the control I attempted to exert over media, over my physical posture and over the results that were appearing on the paper in front of me. In concluding this section by drawing on the writing of Jean-Luc Nancy I advanced the notion that the acts of drawing become ‘subject-forming’, how forms appear to ‘take-shape’ rather than become complete. But whilst these arguments followed in the steps of a substantial number of writers who question the apparent stability between subjects-doing-the-perceiving and objects-being-perceived, it was in the studio that I began to direct attention to the event as a subjective self-creation (Massumi, 2011).

As the site-related works began to come to an end, and the location of artistic production moved into a makeshift studio-office, the second movement took this space as its primary locus. What was at stake in “Islands” was a need to consider how the arguments that had begun to form in Chapter 3 might be brought to bear on the activities that took place within an

Conclusion

environment that is often defined as a peculiarly private domain dedicated to isolated acts of creation. Taking place alongside these considerations was the production of work for the show *Borderlands*. Chapter 4 drew chiefly on two art historical accounts of the studio and a narration of the developing artworks that was directed towards more interconnected understandings of the human-material assemblages that resulted in a series of photographs. The wanderings that had provided opportunities to explore interactions between bodies, environments and materials were now reconsidered in a room that had been repurposed for making studio photographs. Thus this chapter turned towards questions around the peculiarities of the studio, a space which has often been represented as isolated, privileged and containing a singular personal world-view. Guiding perspectives on the studio were two art historical accounts, the first of which explored the mythologies of the Modernist studio and contested the idea of this space as a ‘double enclosure’ (O’Docherty, 2007 p.6); a representation of both an insular room and the mirror of a singular mind. The second looked at two observations that ‘followed’, (to borrow Kontturi’s term), artists, materials, references within this environment. These increasingly fluid and contingent conceptions of the studio are not represented in the developing works, as such, instead they acted as forces that moved the ideas forward. An example was presented in the form of an island ‘motif’ that forms in the visual images, and that appeared to parallel the discourse on the studio. Here the iconic image of the desert island oscillated between histories of Enlightenment exploration and recent writings that present islands as metaphors for Western thought. Threaded between these elements were a number of ruminations on the agencies that act in and on the formation of the digital images, on collaborations and intercessions, and on the perpetual transgression of thresholds between the ‘in-here’ and the ‘out-there’. As with the previous chapter, here personal observations on the creation of work were brought together with writings that tested the idea of a singular directing vision, arguing instead for an understanding that was collaborative—drawing connections between individuals and object-references. As the studio emerged as an identifiable entity I directed attention to the constant redefinition of its perimeter, the movements that bring in and

move out materials and ideas, the negotiation of boundaries between ‘living’ and ‘working’ spaces. In drawing focus on the interrelationship between the activities that go on within this space and those that occur at its threshold, I have positioned the idea of the studio as a space that is formed through practices and interactions that constantly reconfigure and repurpose the elements within it, and that give it a sense of coherence or expression.

The boundaries of the studio are continually traversed. In the material that is distributed for the specific purposes of exhibition, photographic images, diagrams, objects, supplementary texts, explanatory notes, and various other matter is constantly on the move. As test images became thumbnails, developments and then final works they were also drawn into larger assemblages of references, supports, frames, crates, installation instructions, press releases and, perhaps, customs paperwork. Chapter 5 narrates the final movement, and brings together a number of discourses from the first two chapters but turns towards the passage of objects as they move from studio towards exhibition. Taking as its point of departure my own childhood imaginings of Australia drawn from the tourist objects that returned with my grandmother, “Home & Abroad” mapped out a series of connections between souvenir tea towels and charity shop knick-knacks, the miniature illuminated landscapes of Thomas Gainsborough and the works of contemporary artists Gayle Chong Kwan and Richard Wentworth. A body of text that brought together landscape-image and object provided a means of journeying between these connections, and turned the focus of practical research on the production and circulation of images and objects that transported ideas of place, as well as a material presence. The work of Veronica della Dora often provided a means of thinking about the trajectories of objects that emerged from the studio. As with the previous chapters, the emphasis here was on movement, and the hybrid arrangements that travel with ideas in and on objects—in the process forming new relations, new connections and new objects. Although the general thrust of this chapter moved beyond ideas of landscape as a purely iconic or symbolic construct, its representational potency is not entirely ignored. As the works are prepared for Australia some thought is given to the force of the Western landscape

tradition on forming ideas of the Australian landscape, but these too travelled on structures—on canvas supports with a particular tendency to be displayed in certain ways. The final sections of this chapter explored the processes of creating frames and supports that would preserve the photographic images and facilitate their transfer across international borders. And yet in the light and the heat of Australia, what returned to the UK was a reminder both of the temporary social status often given to matter, and of the life that extends way beyond any singular artistic intention.

Taken as a whole, this thesis runs alongside a number of existing texts that have emerged over the last ten to fifteen years in non-representational approaches to cultural geography, and ‘new materialist’ approaches within art history, but it has also threaded a number of these ideas together in novel ways, by interweaving them between a series of autoethnographic accounts of different artistic engagements. In doing so this research has presented an attitude to artistic image-making practices rooted in drawing, digital photography and landscape representation, that moves beyond the iconic and purely representational so as to take account of the way the event of practice involves and confirms ‘subject formation in the materiality of the world’ (Hetherington, 2003, p.1937). This approach has also questioned easy separations between the insular environment of the studio and the ‘real-world’ situations beyond its walls.

The ‘stumble and stutter’ (Thrift, 2008, p.18) of these undertakings is presented here as part of a continual shuttling between writing and practice, in which attempts to make sense of either emerging theoretical or artefactual forms takes place in pulses that appear to move towards a close whilst simultaneously opening up a variety of new potential aesthetic-epistemic objects. Indeed, ‘the doings of writing’ (DeLyster and Hawkins, 2014, p.132) are less obviously articulated here than those of arts practice, but that is in part due to the horizons of this thesis, and the emphasis on the visual work produced during the study. It is this creative practice that is at the core of the text. Put broadly and personally, the reasons I embarked on this research were to locate an ongoing body of work within existing spatial discourses and to extend my approaches to representational image-making in such a

way that they might offer new visual perspectives on spatial experiences. There was a sense that research might also revitalise my practice, provide it with a sense of coherence—an about-ness. These were—and perhaps are—somewhat selfish expectations of research, but through the course of the study I have come to realise that they were also ill-conceived. Following Katie MacLeod’s observations on practice-based research, the study became a means of ‘revealing a practice’ (2000), both in the sense that the engagements between practice and text continually repositioned one another, but also in the sense that these drew close attention to the event of *practicing*. If I had hoped that the process of research might provide a more reasoned way of explaining the outcomes of an image-orientated practice, it did not. The research has, however, drawn my attention to the contingent and relational meshwork of interactions through which work emerges, and to the various transitions, supports and hybrid assemblies that enable the objects created in the various sites or locations of practice to take multiple trajectories and myriad new forms.

Bibliography

- Abrams, J. & Hall, P. (eds.) (2006) *Else/Where-Mapping*. Minneapolis, MN: University of Minnesota Design Institute.
- Alvesson, M. & Skoldberg, K. (2000) *Reflexive Methodology*. London; Thousand Oaks, California: Sage Publications.
- Anderson, B. & Harrison, P. (2010) 'The promise of non-representational theories', in B. Anderson & P. Harrison (eds.) *Taking-place: Non-Representational Theories and Geography*. London: Ashgate. pp. 1–36.
- Anderson, B. & McFarlane, C. (2011) 'Thinking with Assemblage'. *Area*. 43 (2), pp. 162–164.
- Appadurai, A. (1988) 'Introduction: commodities and the politics of value', in Appadurai, A. (ed.) *The Social Life of Things*. 2nd edn. Cambridge; New York: Cambridge University Press. pp. 3–63
- Bachelard, G. (1994) *The Poetics of Space*. Boston: Beacon Press.
- Baker, M. et al. (2005) 'Why traditional storage systems don't help us save stuff forever', in *Proceedings of the First Conference on Hot Topics in System Dependability*. HotDep'05. 2005 Berkeley: USENIX Association. pp. 7–7.
- Baldacchino, G. (2007) 'Islands as novelty sites*'. *Geographical Review*. 97 (2), pp. 165–174.
- Barrett, E. (2010) 'Introduction', in Bolt, B. & Barrett, E. (eds.) *Practice as Research*. London: I.B. Tauris. pp. 1–13.
- Barrett, E. & Bolt, B. (eds.) (2013) *Carnal knowledge*. London; New York: I.B. Tauris.
- Barthel, A. (2006) 'The Paris studio of Constantin Brancusi: A critique of the modern period room'. *Future Anterior*. 3 (2), pp. 34–45.
- Baudrillard, J. (2003) 'The ideological genesis of needs', in Clarke, D. et al. (eds.) *The Consumption Reader*. London; New York: Routledge. pp. 255–258.
- Bellony-Rewald, A. & Peppiatt, M. (1983) *Imagination's Chamber*. London:

Bibliography

Gordon Fraser.

- Bennett, J. (2001) *The Enchantment of Modern Life*. Princeton: Princeton University Press.
- Bennett, J. (2010) *Vibrant Matter*. Durham: Duke University Press.
- Bermingham, A. (2007) 'Introduction: Gainsborough's show box: Illusion and special effects in Eighteenth-Century Britain.' *Huntington Library Quarterly*. 70 (2), pp. 203–208.
- Blunt, A. (2003) 'Collective memory and productive nostalgia: Anglo-Indian homemaking at McCluskieganj.' *Environment and Planning D: Society and Space*. 21 (6), pp. 717–738.
- Bolt, B. (2004) *Art Beyond Representation*. London; New York: I.B. Tauris.
- Bonnett, A. (2006) 'The nostalgias of Situationist subversion.' *Theory, Culture & Society*. 23 (5), pp. 23–48.
- Bonnett, A. & Alexander, C. (2013) 'Mobile nostalgias: connecting visions of the urban past, present and future amongst ex-residents.' *Transactions of the Institute of British Geographers*. 38 (3), pp. 391–402.
- Borgdorff, H. (2012) *The Conflict of the Faculties*. Amsterdam: Leiden University Press.
- Bourdieu, P. (1990) *The Logic of Practice*. Cambridge, UK: Polity Press
- Bourdieu, P. (1993) *Sociology in Question*. London; Thousand Oaks, California: Sage Publications.
- Bourdieu, P. (2003) 'But who created the "creators"?', in Tanner, J. (ed.) *The Sociology of Art: A Reader*. London; New York: Routledge. pp. 96–103.
- Bourriaud, N. (2003) 'Topocritique: l'art contemporain et l'investigation géographique', in Palais de Tokyo GNS, *Global Navigation System: Palais De Tokyo, Site De Création Contemporaine*. Paris: Cercle d'Art. pp. 9–39.
- Boyd Davis, S. (2009) 'Mapping the unseen: making sense of the subjective image,' in Nold, C. (ed.) *Emotional Cartography*. [Online] Available from: <http://www.emotionalcartography.net/EmotionalCartography.pdf>. (Accessed: 6 October 2010)
- Brown, B. & Laurier, E. (2005) 'Maps and journeys: an ethno-methodological investigation.' *Cartographica: The International Journal for Geographic Information and Geovisualization*. 40 (3), pp. 17–33.

- Brown, B. & Perry, M. (2001) 'Of maps and guidebooks: designing geographical technologies.' *ACM SIGGroup Bulletin*. 22 (3), pp. 28–32.
- Brown, E. H. & Phu, T. (eds.) (2014) *Feeling Photography*. Durham: Duke University Press.
- Buren, D. (1988) 'The function of the studio', in Michelson, A. et al. (eds.) *October: The First Decade, 1976-1986*. Cambridge, Massachusetts: MIT Press.
- Burgin, V. (2011) 'Letters'. *Art Monthly*. (348), pp. 16–17.
- Butler, S. (1992) *Gainsborough*. London: Studio.
- Candlin, F. (2005) 'Gayle Chong Kwan: Cockaigne'. *Portfolio Magazine*. (41), pp. 44–49.
- Carrier, J. G. (1995) *Gifts and Commodities Exchange and Western Capitalism Since 1700*. London: Routledge.
- Casey, E. S. (2005) *Earth-Mapping*. Minneapolis: University of Minnesota Press.
- Chare, N. (2006) 'Passages to paint: Francis Bacon's studio practice'. *Parallax*. 12 (4), pp. 83–98.
- Charlesworth, J. J. (2012) 'Letters'. *Art Monthly*. (353), pp. 15–15.
- Chong Kwan, G. (2004) *New Amazonia, Cockaigne* (series) [C-type print]. Collection of the artist.
- Chong Kwan, G. (2007) *51d32m4sN 0d5m18sW, Veduta Romantica* (series) [C-type print]. Collection of the artist.
- Clifford, J. (1986) 'Introduction: partial truths', in James Clifford & George E Marcus (eds.) *Writing Culture: The Poetics and Politics of Ethnography*. Berkeley: University of California Press. pp. 1–26.
- Clough, P. T. (2000) 'Comments on setting criteria for experimental writing'. *Qualitative Inquiry*. 6 (2), pp. 278–291.
- Colloredo-Mansfeld, R. (2003) 'Introduction: matter unbound'. *Journal of Material Culture*. 8 (3), pp. 245–254.
- Coole, D. H. & Frost, S. (eds.) (2010) *New Materialisms*. Durham, North Carolina; London: Duke University Press.
- Cosgrove, D. (2008) 'Cultural cartography: maps and mapping in cultural geography'. *Annales de Géographie*. 2 (660-661), pp. 159–178.

Bibliography

- Crampton, J. W. (2002) 'Thinking philosophically in cartography: toward a critical politics of mapping'. *Cartographic Perspectives*. (41), pp. 4–23
- Crampton, J. W. (2009) 'Cartography: performative, participatory, political'. *Progress in Human Geography*. 33 (6), pp. 840–848.
- Crampton, J. W. & Krygier, J. (2006) 'An introduction to critical cartography'. *ACME: An International E-Journal for Critical Geographies*. 4 (1), pp. 11–33.
- Crag, M. (1997) 'Picturing practices: research through the tourist gaze'. *Progress in Human Geography*. 21 (3), pp. 359–373.
- Cresswell, T. (2004) *Place: A Short Introduction*. Malden, Massachusetts: Blackwell Publishing.
- Cresswell, T. (2014) 'Mobilities III: moving on'. *Progress in Human Geography*. 38 (5), pp. 712–721.
- Crouch, C. (2007) 'Praxis and the reflexive creative practitioner'. *Journal of Visual Art Practice*. 6 (2), pp. 105–114.
- Crouch, D. (2010) *Flirting with Space: Journeys and Creativity*. Farnham, Surrey: Ashgate.
- Cunningham, H. & Heyman, J. (2004) 'Introduction: mobilities and enclosures at borders'. *Identities*. 11 (3), pp. 289–302.
- Curtis, L. (2006) *Polar Wandering*. [Internet based interactive drawing].
- Curtis, L. (2013) *Layla Curtis* [Online]. Available from: <http://www.laylacurtis.com/work> (Accessed: 31 July 2013).
- Davidts, W. (2009) 'My studio is the place where I am (working): Daniel Buren', in Davidts, W. & Paice, K. (eds.) *The Fall of the Studio*. Valiz, Amsterdam: Antennae.
- Davidts, W. & Paice, K. (eds.) (2009) *The Fall of the Studio*. Valiz, Amsterdam: Antennae
- Dean, T. & Millar, J. (2005) *Place*. London: Thames & Hudson.
- De la Mare, W. (1988) *Desert Islands and Robinson Crusoe*. London: Faber.
- De Landa, M. (2006) *A New Philosophy of Society: Assemblage Theory and Social Complexity*. London; New York: Continuum.
- Del Casino, V. J. & Hanna, S. P. (2005) 'Beyond the 'binaries': a methodological intervention for interrogating maps as representational practices'. *ACME: An International E-Journal for Critical Geographies*. 4 (1),

pp. 34–56.

- Deleuze, G. (2004) *Desert Islands and Other Texts, 1953-1974*. Los Angeles, California: Semiotext(e)
- Deleuze, G. & Guattari, F. (2005) *A Thousand Plateaus*. 11th edn. Minneapolis: University of Minnesota Press.
- Della Dora, V. (2006) 'The rhetoric of nostalgia: postcolonial Alexandria between uncanny memories and global geographies'. *Cultural Geographies*. 13 (2), pp. 207–238.
- Della Dora, V. (2007) 'Putting the world into a box: a geography of Nineteenth-century 'travelling landscapes''. *Geografiska Annaler: Series B, Human Geography*. 89 (4), pp. 287–306.
- Della Dora, V. (2009a) 'Taking sacred space out of place: from Mount Sinai to Mount Getty through travelling icons'. *Mobilities*. 4 (2), pp. 225–248.
- Della Dora, V. (2009b) 'Travelling landscape-objects'. *Progress in Human Geography*. 33 (3), pp. 334–354.
- DeLyser, D. & Hawkins, H. (2014) 'Introduction: writing creatively - process, practice, and product.' *Cultural Geographies*. 21 (1), pp.131–134.
- Denzin, N. K. (2009) *Qualitative Inquiry Under Fire*. Walnut Creek, California: Left Coast Press.
- DeSilvey, C. (2006) 'Observed decay: telling stories with mutable things'. *Journal of Material Culture*. 11 (3), pp. 318–338.
- Dewsbury, J.-D. (2003) 'Witnessing space: 'knowledge without contemplation''. *Environment and Planning A*. 35 (11), pp. 1907–1932.
- Doherty, C. (2004) *From Studio to Situation*. London: Black Dog Publishing.
- Driver, F. & Martins, L. de L. (2005) 'Views and visions of the tropical world', in Driver, F. & Martins, L. de L. (eds.) *Tropical Visions in an Age of Empire*. Chicago: University of Chicago Press.
- Duncan, M. (2004) 'Autoethnography: critical appreciation of an emerging art'. *Journal of Qualitative Methods*. 3 (4, Article 3). [Online] Available from: https://www.ualberta.ca/~iiqm/backissues/3_4/pdf/duncan.pdf. (Accessed: 9 January 2015)
- Eco, U. (1997) *The Island of the Day Before*. London: Minerva.
- Edwards, E. & Hart, J. (eds.) (2004) *Photographs Objects Histories*. London; New

Bibliography

- York: Routledge.
- Elkins, J. (1999) *What Painting Is*. London; New York: Routledge.
- Ellis, C. & Bochner, A. C. (2000) 'Autoethnography, personal narrative, reflexivity: researcher as subject', in Denzin, N. K. & Lincoln, Y. S. (eds.) *Handbook of Qualitative Research*. 8th edn. Thousand Oaks, California: Sage Publications. pp. 733–768.
- Ellis, C. et al. (2011) 'Autoethnography: an overview'. *Forum Qualitative Sozialforschung / Forum: Qualitative Social Research*. 12 (1), Art. 10. [Online] Available from: <http://www.qualitative-research.net/index.php/fqs/article/view/1589/3095>. (Accessed: 10 January 2015)
- Engels-Schwarzpaul, A.-C. (2008) 'At a loss for words? hostile to language? interpretation in creative practice-led PhD projects'. *Working Papers in Art and Design*. 5. [Online]. Available from: https://www.herts.ac.uk/__data/assets/pdf_file/0009/12420/WPIAAD_vol15_christina_schwarzpaul.pdf (Accessed: 25 August 2009).
- Foá, M. (2004) *Walking Drawing*. [Online]. Available from: http://www.maryclarefoa.com/foa_walking_txt.html. (Accessed: 20 April 2015)
- Foá, M. (2011) *Sounding out: performance drawing in response to the outside environment*. Doctoral thesis (monograph). London: University of the Arts London.
- Frayling, C., (1994), 'Research in art and design' *Royal College of Art Research Papers*, 1 (1), pp. 1–5.
- Furniss, H. (1892) *Flying visits*. New York: United States Book Company. [Online] Available from: <http://catalog.hathitrust.org/Record/008916273>. (Accessed: 10 April 2010)
- Gannon, S. (2006) 'The (im)possibilities of writing the self-writing: French poststructural theory and autoethnography'. *Cultural Studies <=> Critical Methodologies*. 6 (4), pp. 474–495.
- Gainsborough, T. (c.1746) *Landscape in Suffolk* [Oil on canvas] Kunsthistorisches Museum, Vienna.
- Gardiner, C. (1958) *The Western Horizon of Victoria Australia*. Melbourne: Australian Publicity Council.
- Gell, A. (1998) *Art and Agency*. Oxford; New York: Clarendon Press.
- Gillis, J. R. (2007) 'Island sojourns'. *Geographical Review*. 97 (2), pp. 274–287.

- Gillis, J. R. (2010) *Islands of the Mind*. New York: Palgrave Macmillan.
- Goddard, M. (2000) 'Of cabbages and kin: the value of an analytic distinction between gifts and commodities'. *Critique of Anthropology*. 20 (2), pp. 137–151.
- Gordon, B. (1986) 'The souvenir: messenger of the extraordinary'. *Journal of Popular Culture*. 20 (3), pp. 135–146.
- Gouma-Peterson, T. (1997) 'Miriam Schapiro: an art of becoming'. *American Art*. 11 (1), pp. 10–45.
- Gray, C. & Malins, J. (2004) *Visualizing Research*. Aldershot, Hants; Burlington, Vermont: Ashgate.
- Graham, R. (1997) *Vexation Island*. [35mm Film]. Lisson Gallery, London.
- Gregory, C. A. (1982) *Gifts and Commodities*. London; New York: Academic Press.
- Gregory, D. (ed.) (2009) *The Dictionary Of Human Geography*. 5th Edition. Chichester, West Sussex: Wiley-Blackwell.
- Gregson, N. & Crewe, L. (2003) *Second-Hand Cultures*. Oxford: Berg.
- Greppi, C. (2005) "'On the spot": traveling artists and the iconographic inventory of the world, 1769-1859', in Driver, F. & Martins, L. de L. (eds.) *Tropical Visions in an Age of Empire*. Chicago: University of Chicago Press. pp. 23–42.
- Grosz, E. A. (2005) *Time Travels*. Durham, NC: Duke Univ. Press.
- Haldrup, M. & Larsen, J. (2006) 'Material cultures of tourism'. *Leisure Studies*. 25 (3), pp. 275–289.
- Harley, J. B. (1989) 'Deconstructing the map'. *Cartographica: The International Journal for Geographic Information and Geovisualization*. 26 (2), pp. 1–20.
- Harrison, C. & Wood, P. (eds.) (1993) *Art in Theory, 1900-1990: An Anthology of Changing Ideas*. Oxford; Cambridge, Massachusetts: Blackwell.
- Hartoum, M. (1994) *Corps Étranger*. [Video installation]. White Cube Gallery, London.
- Haseman, B. (2006) 'A manifesto for performative research'. *Media International Australia incorporating Culture and Policy, theme issue 'Practice-led Research'*. (118), pp. 98–106.
- Hawkins, H. (2010a) 'Collection as artistic practice: the geographies of

Bibliography

- collection and politics of display in the installations of Tomoko Takahashi'. *Women's Studies*. 39 (6), pp. 647–672.
- Hawkins, H. (2010b) 'Turn your trash into... rubbish, art and politics. Richard Wentworth's geographical imagination'. *Social & Cultural Geography*. 11 (8), pp. 805–827.
- Hawkins, H. (2010c) 'Visions of excess'. *Angelaki*. 15 (2), pp. 19–37.
- Hawkins, H. (2014) *For Creative Geographies*. New York: Routledge.
- Hayes, J. (1980) *Thomas Gainsborough*. London: Tate Gallery.
- Heleniak, K. M. (1999) 'A Victorian Salon: Paintings from the Russell-Cotes Art Gallery and Museum'. *CAA.Reviews*.
- Helmreich, A. (2013) 'Defining, shaping, and picturing landscape in the Nineteenth Century', in Arnold, D. & Corbett, D. P. (eds.) *A Companion to British art 1600 to the present*. Chistester: Wiley-Blackwell. pp. 315–350.
- Hennessy, E. & McCleary, A. L. (2011) 'Nature's Eden? The production and effects of 'pristine' nature in the Galápagos Islands'. *Island Studies Journal*. 6 (2), pp. 131–156.
- Hetherington, K. (2003) 'Spatial textures: place, touch, and praesentia'. *Environment and Planning A*. 35 (11), pp. 1933–1944.
- Holmes, B. (2006) 'Counter cartographies', in Abrams, J. & Hall, P. (eds.) *Else/Where-Mapping: New Cartographies of Networks and Territories*. Minneapolis: University of Minnesota Design Institute.
- Holt, N. L. (2003) 'Representation, legitimation, and autoethnography: an autoethnographic writing story'. *International Journal of Qualitative Methods*. 2 (1), pp. 18–28.
- Ingold, T. (2007) *Lines*. London; New York: Routledge.
- Ingold, T. (2011) *Being Alive*. London; New York: Routledge.
- Institute for Applied Autonomy (n.d.) *Institute for Applied Autonomy | Tactical Cartographies (excerpt)* [Online]. Available from: http://an-atlas.com/contents/iaa_iaa.html (Accessed: 9 August 2013).
- Jacob, M. J. & Grabner, M. (eds.) (2010) *The Studio Reader: On the Space of Artists*. Chicago ; London: University of Chicago Press.
- James, W. (1909) *A Pluralistic Universe. Hibbert Lectures at Manchester College on the Present Situation in Philosophy*. Project Gutenberg. [Online]. Available

- from: <http://www.gutenberg.org/ebooks/11984> (Accessed: 8 August 2014).
- Joseph, P. (2000) *Mon Plan de métro de Paris*. [Digital print on aluminium] Air de Paris, Paris.
- Kiaer, I. (2013) 'Studio', in Fisher, E., & Fortnum, R., (eds.) *On Not Knowing: How Artists Think*. London: Black Dog Publishing.
- Kierulf, A. (2015) 'Printmaking and Place'. *Journal of Visual Art Practice*. 14 (3), pp. 192–202.
- Kitchin, R. & Dodge, M. (2007) 'Rethinking maps'. *Progress in Human Geography*. 31 (3), pp. 331–344.
- Kitchin, R. et al. (2009) 'Thinking about maps', in Dodge, M. et al. (eds.) *Rethinking Maps*. London: Routledge. pp. 1–25.
- Kjørup, S. (2011) 'Pleading for plurality: artistic and other kinds of research', in Biggs, M. & Karlsson, H. (eds.) *The Routledge companion to research in the arts*. London; New York: Routledge. pp. 24–43.
- Klee, P. (1961) *Paul Klee: The Thinking Eye*. London: Lund Humphries.
- Knorr-Cetina, K. (2001) 'Objectual practice', in Schatzki, T. R. et al. (eds.) *The Practice Turn in Contemporary Theory*. New York: Routledge. pp. 184–197.
- Kontturi, K-K. (2012) *Following the Flows of Process: Towards a New Materialist Account of Contemporary Art*. Doctoral thesis (monograph). Turku: University of Turku.
- Kopytoff, I. (1988) 'The cultural biography of things', in Appadurai, A. (ed.) *The Social Life of Things*. 2nd edn. Cambridge; New York: Cambridge University Press.
- Kuhn, T. S. (1996) *The Structure of Scientific Revolutions*. Chicago, Illinois: University of Chicago Press.
- Kwon, M. (2004) *One Place After Another*. Cambridge, Massachusetts: MIT Press.
- Larsen, J. (2008) 'Practices and flows of digital photography: an ethnographic framework'. *Mobilities*. 3 (1), pp. 141–160.
- Larsen, J. (2014) 'The (im)mobile life of digital photographs: the case of tourist photography', in Larsen, J. & Sandbye, M. (eds.) *Digital Snaps*:

Bibliography

- the new face of Photography*. London; New York: I. B. Tauris.
- Larsen, J. & Sandbye, M. (eds.) (2014) *Digital Snaps*. London; New York: I. B. Tauris.
- Latour, B. (1988) 'The politics of explanation: an alternative', in Woolgar, S. (ed.) *Knowledge and Reflexivity*. London: Sage Publications. pp. 155–176.
- Latour, B. (1999) *Pandora's Hope*. Cambridge, Massachusetts: Harvard University Press.
- Latour, B. & Woolgar, S. (1986) *Laboratory Life*. Princeton, New Jersey: Princeton University Press.
- Laurier, E. (2013) *The Lives Hidden by the Transcript and the Hidden Lives of the Transcript*. [Online]. Available from: http://www.ericlaurier.co.uk/resources/Writings/Laurier_2013_Hidden_Transcript.pdf (Accessed: 10 August 2014).
- Lawson, J. A. (1875) *Wanderings in the interior of New Guinea*. London: Chapman & Hall. [Online]. Available from: <http://catalog.hathitrust.org/Record/006577351>. (Accessed: 6 September 2008)
- Lindsley, R. (1997) 'A voyage to and from Rodney Graham's Isle of Vexation', in Graham, R. (ed.) *Island thought: Canada XLVII Biennale di Venezia*. North York, Ontario: Art Gallery of York University.
- Lindqvist, M. (2008) *Untitled, Rågskär Island* (series), 2008 [C-Type print]. Collection of the artist.
- Lippard, L. & Chandler, J. (1968) 'The dematerialization of art'. *Art International*. (February), pp. 31–36.
- Lorimer, H. (2005) 'Cultural geography: the busyness of being 'more-than-representational''. *Progress in Human Geography*. 29 (1), pp. 83–94.
- Lorimer, H. (2010) 'Caught in the nick of time: archives and fieldwork', in DeLyser, D. et al. (eds.) *The Sage handbook of qualitative geography*. London: Sage Publications. pp. 248–274.
- Lowenthal, D. (2007) 'Islands, lovers, and others'. *Geographical Review*. 97 (2), pp. 202–229.
- Lynch, M. (2000) Against reflexivity as an academic virtue and source of privileged knowledge. *Theory, Culture & Society*. 17 (3), 26–54.
- Mäkela, M., et al. (eds.) (2011) Editorial: on reflecting and making in artistic

- research. *Journal of Research Practice* 7 (1), Article E1.
- MacLeod, K. (2000) The functions of the written text in practice-based PhD submissions. *Working Papers in Art and Design*. 1. [Online]. Available from: http://www.herts.ac.uk/__data/assets/pdf_file/0004/12289/WPIAAD_vol1_macleod.pdf (Accessed: 25 August 2009).
- Madoff, S. H. (2009) *What is Art Education?: A Twenty-First-Century Question*. Cambridge, Massachusetts: MIT Press.
- Manning, E. (2009) *Relationscapes*. Technologies of lived abstraction. Cambridge, Massachusetts: MIT Press.
- Manning, E. & Massumi, B. (2014) *Thought in the Act*. Minneapolis: University of Minnesota Press.
- Marcus, G. E. & Saka, E. (2006) 'Assemblage'. *Theory, Culture & Society*. 23 (2-3), pp. 101–106.
- Massey, D. B. (1994) *Space, Place, and Gender*. Minneapolis: University of Minnesota Press.
- Massey, D. B. (2005) *For Space*. London; Thousand Oaks, California: Sage Publications.
- Massumi, B. (2011) *Semblance and Event*. Cambridge, Mass.: MIT Press.
- Matless, D. (1998) *Landscape and Englishness*. London: Reaktion.
- Maton, K. (2003) 'Pierre Bourdieu and the epistemic conditions of social scientific knowledge'. *Space and Culture*. 6 (1), pp. 52–65.
- Mauss, M. (2002) *The Gift*. London; New York: Routledge.
- McCarthy, T. (2014) 'Introduction', in Obrist, H. U. (ed.) *Mapping It Out*. London; New York: Thames & Hudson.
- McCormack, D. P. (2003) 'An event of geographical ethics in spaces of affect'. *Transactions of the Institute of British Geographers*. 28 (4), pp. 488–507.
- McCormack, D. P. (2008) 'Geographies for moving bodies: thinking, dancing, spaces'. *Geography Compass*. 2 (6), pp. 1822–1836.
- McDonough, T. F. (1994) 'Situationist space'. *October*. 67 (Winter), pp. 59–77.
- Mendelson, C. (2008) 'Writers' rooms'. *The Guardian (Review)*. 15 March. p.3.
- Miller (1998) *Material Cultures*. Chicago: University of Chicago Press.
- Miller, D. (2001) 'Alienable Gifts and Inalienable Commodities', in Myers,

Bibliography

- F. R. (ed.) *The Empire of Things*. Santa Fe, New Mexico: School of American Research Press.
- Miller, D. (2008) *The Comfort of Things*. Cambridge: Polity.
- Miller, D. (ed.) (2005) *Materiality*. Durham: Duke University Press.
- Mitchell, W. J. T. (2002) *Landscape and Power*. 2nd edn. Chicago: University of Chicago Press.
- Mitchell, W. J. T. (2005) *What Do Pictures Want?* Chicago, Illinois: University of Chicago Press.
- Muncey, T. (2005) 'Doing autoethnography'. *International Journal of Qualitative Methods*. 4 (1). [Online] Available from: https://www.ualberta.ca/~iiqm/backissues/4_1/pdf/muncey.pdf. (Accessed: 9 January 2015)
- Nancy, J.-L. (2013) *The Pleasure in Drawing*. New York: Fordham University Press.
- Nold, C. (ed.) (2009) *Emotional Cartography*. [Online]. Available from: <http://emotionalcartography.net/> (Accessed: 18 June 2010).
- Nold, C. (2005) *Greenwich Emotion Map*. [Digital Image]. Available from: <http://emotionmap.net/GreenwichEmotionMap.pdf> (Accessed: 13 April 2007).
- O'Doherty, B. (2007) *Studio and Cube*. New York: Columbia University.
- O'Sullivan, S. (2006) *Art Encounters Deleuze and Guattari*. Basingstoke; New York: Palgrave Macmillan.
- Olalquiaga, C. (1999) *The Artificial Kingdom*. London: Bloomsbury.
- Olin, M. R. (2012) *Touching Photographs*. Chicago, Illinois: University of Chicago Press.
- Olwig, K. R. (2002) *Landscape, Nature, and the Body Politic*. Madison: University of Wisconsin Press.
- Olwig, K. R. (2005) 'Representation and alienation in the political landscape'. *Cultural Geographies*. 12 (1), pp. 19–40.
- Olwig, K. R. (2007) 'Are islanders insular? a personal view*'. *Geographical Review*. 97 (2), pp. 175–190.
- Patterson, S. (1992) *The Great Bear*. [Lithograph on paper]. Tate Gallery, London.

- Pels, D. (2000) 'Reflexivity: one step up'. *Theory, Culture & Society*. 17 (3), pp. 1–25.
- Pentikäinen, J. (2006) 'The reconciliation of the hostile ones: writing as a method in art and design research practices'. *Working Papers in Art and Design*. 4. [Online]. Available from: <http://www.herts.ac.uk/artdes/research/papers/wpades/vol4/jpfull.html>. (Accessed: 25 August 2009)
- Hay, P. (2006) 'A phenomenology of islands'. *Island Studies Journal*. 1 (1), pp. 19–42.
- Peters, K. (2011) 'Negotiating the 'place' and 'placement' of banal tourist souvenirs in the home'. *Tourism Geographies*. 13 (2), pp. 234–256.
- Phillips, J. (2006) 'Agencement/Assemblage'. *Theory, Culture & Society*. 23 (2–3), pp. 108–109.
- Pickles, J. (2004) *A History of Spaces*. London; New York: Routledge.
- Price, E. et al. (2011) 'Letters'. *Art Monthly*. (350), pp. 17–19.
- Proboscis (2002) *Urban Tapestries*. [Online]. Available from: <http://research.urbantapestries.net/> (Accessed: 2 June 2007).
- Proboscis (2004) *Social Tapestries*. [Online]. Available from: <http://socialtapestries.net/>. (Accessed: 2 June 2007)
- Pungetti, G. (2012) 'Islands, culture, landscape and seascape'. *Journal of Marine and Island Cultures*. 1 (2), pp. 51–54.
- Ramsay, N. (2009) 'Taking-place: refracted enchantment and the habitual spaces of the tourist souvenir'. *Social & Cultural Geography*. 10 (2), pp. 197–217.
- Reynolds, J. (1965) *Discourses on Art*. New York: The Bobbs-Merrill Company.
- Ritchie, J. E. (1977) 'Cognition of place' *Ethos*. 5 (2), pp. 187–194.
- Rogoff, I. (2000) *Terra Infirma: Geography's Visual Culture*. London; New York: Routledge.
- Rogoff, I. (2010) *Iniva: Keynote speaker Prof Irit Rogoff with Dr Harriet Hawkins*. [Online]. Available from: http://www.iniva.org/events/2010/mapping_symposium/crossing_boundaries_audio/keynote (Accessed: 25 January 2015).
- Rogoff, I. (2013) *Unbounded—Limits' Possibilities*. New York; Berlin: Lukas &

Bibliography

- Sternberg.
- Ronström, O. (2013) 'Finding their place: islands as locus and focus'. *Cultural Geographies*. 20 (2), 153–165.
- Rose, G. (2003) 'On the need to ask how, exactly, is geography 'visual'?' *Antipode*. 35 (2), pp. 212–221.
- Rosenthal, M. & Myrone, M. (eds.) (2002) *Thomas Gainsborough: 1727-1788*. New York: Abrams.
- Sahlins, M. D. (1972) *Stone Age Economics*. Chicago: Aldine-Atherton.
- Sassoon, J. (2004) 'Photographic materiality in the age of digital reproduction', in Edwards, E. & Hart, J. (eds.) *Photographs Objects Histories: On the Materiality of Images*. London; New York: Routledge. pp. 186–202.
- Scrivener, S. (2011) 'Transformational practice', in Biggs, M. & Karlsson, H. (eds.) *The Routledge Companion to Research in the Arts*. London; New York: Routledge. pp. 259–267.
- Sennett, R. (2009) *The Craftsman*. London: Penguin.
- Sheller, M. (2011) Mobility. *Sociopedia.isa*. [Online]. Available from: <http://www.sagepub.net/isa/resources/pdf/mobility.pdf>. (Accessed: 9 March 2014)
- Sheller, M. & Urry, J. (2006) 'The new mobilities paradigm'. *Environment and Planning A*. 38 (2), pp. 207–226.
- Sherry, J. F. (1983) 'Gift giving in anthropological perspective'. *The Journal of Consumer Research*. 10 (2), pp. 157–168.
- Singerman, H. (2010) 'A possible contradiction', in Jacob, M. J. & Grabner, M. (eds.) *The Studio Reader*. Chicago: School of the Art Institute of Chicago: University of Chicago Press. pp. 39–46.
- Slager, Henk (2011) 'Differential iconography', in Biggs, M. & Karlsson, H. (eds.) *The Routledge Companion to Research in the Arts*. London; New York: Routledge. pp. 333–352
- Sleeman, J. (2012) 'The New Art, Hayward Gallery, London, 1972: new as compromise, or when what happens around the exhibition is as interesting as what happens in the exhibition'. *Sculpture Journal*. 21 (2), pp. 63–74.

- Smith, H. & Dean, R. T. (2009) *Practice-led research, research-led practice in the creative arts*. Edinburgh: Edinburgh University Press.
- Soane Museum (2001) *Retrace Your Steps: Remember Tomorrow*.
- Stewart, R. (2003) '(Re)inventing artists' research: constructing living forms of theory.' *TEXT*. 7 (2), [Online] Available from: <http://www.textjournal.com.au/oct03/stewart.htm> (Accessed: 28 September 2013)
- Stewart, S. (1993) *On Longing*. Durham: Duke University Press.
- Steyerl, H. (2012) *The Wretched of the Screen*. Berlin: Sternberg Press.
- Stott, T. (2004) 'Next on the Left, or: 'What good is a map if you know the way?'. *Variant*. 2 (21), pp. 13–16.
- Strathern, M. (1988) *The Gender of the Gift*. Berkeley: University of California Press.
- Stratford, E. (2003) 'Flows and boundaries: small island discourses and the challenge of sustainability, community and local environments'. *Local Environment*. 8 (5), pp. 495–499.
- Stratford, E. et al. (2011) 'Envisioning the archipelago'. *Island Studies Journal*. 6 (2), pp. 113–130.
- Suchin, P. (2011) 'Rebel without a course'. *Art Monthly*. (345), pp. 11–14.
- Suchin, P. et al. (2012) 'Letters'. *Art Monthly*. (354), pp. 16–17.
- Sullivan, G. (2005) *Art Practice as Research*. Thousand Oaks, California: Sage Publications.
- Taylor, B. (1951) *Gainsborough (1727-1788)*. London: Faber and Faber.
- Taylor, C. & Peloton (2012) *Drawing Lines in the Sand*. Chippendale, New South Wales: Peloton Gallery.
- Taylor, K. (2006) *Country & Landscape*. Canberra: National Library of Australia.
- Thoma, A. (2006) 'The Making of 'Place' to Enable Memory'. *Journal of Visual Art Practice*. 5 (1and 2), pp. 83–93.
- Thomas, M. (2009) 'Studio Vertigo: Mark Rothko', in Davidts, W. & Paice, K. (eds.) *The Fall of the Studio*. Valiz, Amsterdam: Antennae. pp. 23–42.
- Thomson, A. (2013) 'Making a Place: Art, writing, and a more-than-textual approach'. *Geographical Review*. 103 (2), pp. 244–255.

Bibliography

- Thompson, N. (2008) *Experimental Geography*. Brooklyn, New York: Melville House.
- Thrift, N. J. (2008) *Non-Representational Theory*. Abingdon, Oxon; New York: Routledge.
- Tolia-Kelly, D. P. (2008) 'Motion/emotion: picturing translocal landscapes in the 'Nurturing Ecologies' research project'. *Mobilities*. 3 (1), pp. 117–140.
- Tuan, Y. (1990) *Topophilia*. New York: Columbia University Press.
- Tuan, Y. (2001) *Space and Place*. Minneapolis: University of Minnesota Press.
- Ulrich Obrist, H. (ed.) (2014) *Mapping It Out*. New York: Thames & Hudson.
- Vannini, P. & Taggart, J. (2013) 'Doing islandness: a non-representational approach to an island's sense of place'. *Cultural Geographies*. 20 (2), pp. 225–242.
- Vannini, P. (2015) 'Non-representational methodologies: An Introduction', in Vannini, P. (ed.) *Non-representational methodologies*. New York: Routledge.
- Vaughan, L. (2009) 'Walking the line: affectively understanding and communicating the complexity of place'. *The Cartographic Journal*. 46 (4), pp. 316–322.
- Wall, S. (2008) 'Easier said than done: writing an autoethnography'. *International Journal of Qualitative Methods*. 7 (1), pp. 38–53.
- Wallace, I. (1993a) *Corner of the Studio I-IV*. [Painting/Photographs]. Catriona Jeffries Gallery, Vancouver.
- Wallace, I. (1993b) *El Taller I-IV*. [Painting/Photographs]. Catriona Jeffries Gallery, Vancouver.
- Wallace, I. (2012) 'Corner of the Studio and El Taller: a reflection on two works from 1993/2005', in Hoffmann, J. (ed.) *The Studio*. London; Cambridge, Massachusetts: Whitechapel Gallery; MIT Press. pp. 170–179.
- Waterfield, G. (1999) 'Paintings from the Russell-Cotes Art Gallery and Museum, Bournemouth'. *Antiques* 155 (6) pp. 858–865.
- Waterfield, G. (2009) 'The artist's studio', in Waterfield, G. (ed.) *The Artist's Studio*. Compton Verney: Hogarth Arts.
- Waterhouse, E. (1958) *Gainsborough*. London: Edward Hulton.

- Watson, R. (2009) 'Mapping and contemporary art'. *The Cartographic Journal*. 46 (4), pp. 293–307.
- Wentworth (1988) *Five Sculptors: Richard Wenworth*. 26 May. [Online]. Available from: <http://www.bbc.co.uk/archive/sculptors/12810.shtml> (Accessed: 18 April 2012).
- Whatmore, S. (2006) 'Materialist returns: practising cultural geography in and for a more-than-human world'. *Cultural Geographies*. 13 (4), pp. 600–609.
- Whitley, W. T. (1915) *Thomas Gainsborough*. London: Smith, Elder & Co.
- Withers, C. W. J. (1999) 'Geography, Enlightenment, and the paradise question', in Livingstone, D. N. & Wither, C. W. J. (eds.) *Geography and Enlightenment*. Chicago: University of Chicago Press. pp. 67-92.
- Wood, D. (1992) *The Power of Maps*. New York: Guilford.
- Wood, W. (1999) 'Still you ask for more: demand, display and "the New Art"', in Newman, M. & Bird, J. (eds.) *Rewriting Conceptual Art*. London: Reaktion Books.
- Wylie, J. (2007) *Landscape*. London; New York: Routledge.
- Žižek, S. (1991) *Looking Awry*. Cambridge, Mass.: MIT Press.

