



## Review

## A review of the sustainable methods in imparting shrink resistance to wool fabrics



 Mohammad M. Hassan<sup>a,\*</sup>, Christopher M. Carr<sup>b</sup>
<sup>a</sup> Bioproduct & Fiber Technology Team, AgResearch Ltd, Private Bag 4749, Christchurch 8140, Canterbury, New Zealand

<sup>b</sup> School of Design, University of Leeds, Leeds LS2 9JT, United Kingdom

## HIGHLIGHTS

- Wool fibers are shrink-resist treated to make the wool garments machine washable.
- The scales available on wool fiber surface are responsible for felting shrinkage.
- Various treatments have been investigated to make wool garments shrink-resistant.
- The chlorine-Hercosett process is the most effective but harmful to the environment.
- The future trend of green and sustainable alternatives treatments are discussed.

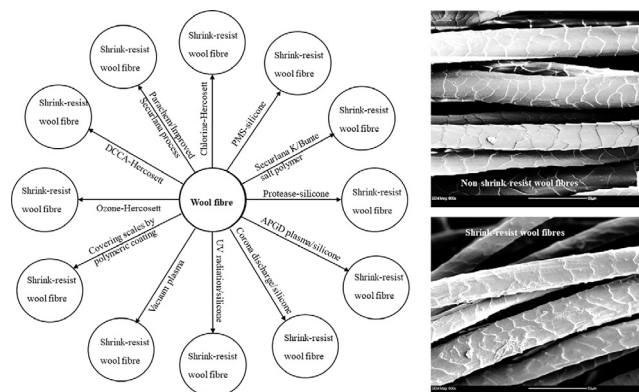
## GRAPHICAL ABSTRACT



## ARTICLE INFO

## Article history:

Received 5 October 2018

Revised 24 January 2019

Accepted 25 January 2019

Available online 31 January 2019

## Keywords:

 Wool fiber  
 Shrink-resistance  
 Polymeric coating  
 Oxidation  
 Plasma radiation  
 Sustainability

## ABSTRACT

Wool fiber is a natural protein fiber, which is used for the manufacturing of apparels, and floorcoverings because of its excellent fire retardancy, stain-resistance, antistatic and odor control properties along with exceptional warmth and resilience. However, wool fiber has several serious demerits, such as garments made of wool fibers extensively shrink during their laundering. To overcome this problem, wool fibers, especially those are used in apparel, are frequently shrink-resist treated to make them machine-washable. A wide range of treatments including oxidative, enzymatic, radiation, polymeric coatings, sol-gel coatings, and plasma treatments have been investigated to make wool fiber shrink-resistant. In this review, the mechanisms of wool fiber shrinkage, the research carried out until recently to make wool fiber shrink-resistant, and the current status of the sustainable alternatives developed, have been compiled and presented. The various methods investigated have been critically discussed with their merits and demerits, shrink-resist performance, and their shrink-resistance mechanisms. The chemistry and synthesis of various polymers used for the shrink-resistance and their reactions with wool fiber have been outlined. This review also includes the current challenges to make shrink-resist treatments green and sustainable, and also the future directions to meet these challenges. Some of the treatments investigated may affect the biodegradability of wool fibers, especially those are based on coating with synthetic polymers. A sustainable alternative polymeric coating based on sustainably produced polymeric resins, especially bio-based resins, needs to be developed so that the future treatments become sustainable.

© 2019 The Authors. Published by Elsevier B.V. on behalf of Cairo University. This is an open access article under the CC BY-NC-ND license (<http://creativecommons.org/licenses/by-nc-nd/4.0/>).

Peer review under responsibility of Cairo University.

\* Corresponding author.

E-mail address: [mahbubul.hassan@agresearch.co.nz](mailto:mahbubul.hassan@agresearch.co.nz) (M.M. Hassan).
<https://doi.org/10.1016/j.jare.2019.01.014>

2090-1232/© 2019 The Authors. Published by Elsevier B.V. on behalf of Cairo University.

This is an open access article under the CC BY-NC-ND license (<http://creativecommons.org/licenses/by-nc-nd/4.0/>).

## Introduction

Wool fiber is a luxury fiber with exceptional warmth, resilience, elasticity, fire-retardancy, quick-dryability, and antistatic properties [1,2]. Recently wool fiber has drawn attention because of its various attributes including its natural origin. However, wool fiber-made apparels are susceptible to felting and shrinking during washing affecting not only their aesthetic properties but also affecting their dimension to the extent that the garments can no longer be used [1–3]. The special characteristics of wool fiber surface make it susceptible to felting and shrinking. Wool garments shrink to average 55% of their original dimension after the first laundering. Therefore, shrink-resistance is important for the application of wool in apparels, quilts, curtains, pillows, and bedding.

A range of treatments has been developed over the years to make wool fabric felt and shrink resistant. Of all the treatments investigated, the chlorination treatment followed by coating with a polyamide-epichlorohydrin resin (known as chlorine-Hercosett treatment) is undoubtedly the most effective, and the cheapest shrink-resist treatment. It is believed that approximately 70% of all wool labeled as fully machine-washable is treated by the chlorine-Hercosett process [5], which has become an industry standard for making machine-washable wool [4]. Mori and Matsudaira used calcium hypochlorite in a combination with hydrogen peroxide ( $H_2O_2$ ) but the achieved shrink-resistance was poor compared to the acid chlorination process [6]. The chlorine-Hercosett process is used for the continuous shrink-resist treatment of wool tops, which is an energy-efficient process but it affects the handle properties of wool fabrics. Moreover, this process produces an effluent containing AOX coming from both the chlorinating agent and the Hercosett resin, making it environmentally hazardous. Therefore, in developed countries, industrial use of the chlorine/Hercosett process is restricted as the produced effluent exceeds the consent limit set for the discharge of AOX to watercourses. Some other chlorine-based shrink-resist treatments, such as Kroy-Hercosett process, use gaseous chlorine instead of NaOCl. In the Kroy-Hercosett process, the chlorination is carried out by vertically immersing wool tops in the Kroy Deep-Immersion Chlorinator, which is a compact and closed loop chlorination system [7]. The gaseous chlorine is mixed with water by an injector producing hypochlorous acid (HOCl), which is injected into the chlorinator that greatly improves the uniformity of chlorination treatment compared to the chlorine-Hercosett treatment. Any unreacted chlorine gas coming out of the chlorinator is passed through a chlorine scrubber unit that converts chlorine to sodium chloride. Usually, no anti-chlorination and neutralization of chlorinated fiber are required as chlorine in the treated fiber becomes undetectable. However, HCl could remain in the fiber after the chlorination treatment, which makes the treated fibers smelly and therefore sometimes neutralization is carried out.

DCCA is one of the oldest chlorinating agents being investigated for imparting shrink-resistance to wool fiber. The chlorination is carried out at pH 2.0–3.0 at room temperature but anti-chlorination is required before depositing polymeric coatings on wool. It was reported that the DCCA treatment is more effective than the traditional acid chlorination treatments in forming a uniform deposition of Hercosett resin deposition onto wool fibers [8]. The etching of cuticles usually increases with an increase in the DCCA dosage to the point that complete removal of scales occurs, but it causes yellowing of the wool fibers and also negatively affects the handle properties of the fabric made from these fibers [9,10]. The Basolan DC process developed by BASF AG (Germany) could be an example. It was found that the best shrink-resistance and the least degradation of fiber are achieved with a Basolan DC concentration between 2.5 and 4.5% on the wight of fiber (owf)

at a pH 4–5 [11]. However, the treatment cannot be carried out in the continuous mode because of the precipitation of DCCA at low pH. To overcome this problem, the South African Wool and Textile Research Institute (SAWTRI) used a combination of a mineral acid (e.g. hydrochloric acid) and acetic acid. The DCCA solution made by this method is stable at pH 1.5–2.5 for a period long enough to allow the continuous chlorination of wool fiber [12]. However, the high price of DCCA compared to the price of NaOCl or gaseous chlorine made it a failure.

The alternatives to chlorination are peroxymonosulfuric acid (PMS), peracetic acid and ozone-based treatments that do not produce AOX-laden effluent. Denning et al. investigated the reactivity of different oxidants used for the shrink-resist treatment of wool and found that PMS is slightly inferior to chlorine and DCCA but stronger than peracetic acid, persulfate, and  $H_2O_2$  [13]. At the beginning of this millennium, enzyme-based treatments were envisaged as a sustainable and eco-friendly alternative to the chlorine-based shrink-resist treatments for wool and other animal fibers. The proteolytic enzymes (e.g. protease) are the most investigated enzymes for imparting shrink-resistance to wool fiber [14–17]. The other enzymes investigated are lipase and papain [18,19]. The treatment with a proteolytic enzyme is carried out at mild alkaline conditions (pH 8.0 to 9.0) in a batch-mode with an enzyme dosage of 2 to 3% owf at 55–60 °C for 1 to 2 h [15]. It was found that the protease treated wool fabric showed considerably higher dye uptake compared to the untreated wool but lower compared to the chlorine-Hercosett treated wool [16]. However, enzymatic treatment alone cannot provide the required level of shrink-resistance without the polymeric coating. Several bio-based polymers alone or in a combination with oxidation treatments have been investigated for the shrink-resistance of wool with limited success [20,21]. Plasma treatments also have been investigated but mainly non-polymerizing gasses were used, which increased the degradation of wool fiber. Polymerizing gaseous monomers could be used to overcome this problem. The coating of wool fibers with non-biodegradable synthetic polymers may affect the biodegradability of wool fiber. Therefore, future research should focus on developing a shrink-resist treatment for wool based on coating with biodegradable polymers. Sustainability considerations are getting importance recently and therefore the future shrink-resist processes will need to be sustainable and cost incentive.

This review article deals with the traditional shrink-resist treatments used in industry, their shrink-resist performance and merits/demerits along with the new eco-friendly and sustainable alternatives developed until recently, and current challenges and future directions. The structure of the wool fiber, mechanism of shrinkage of wool fiber, the chemistry of various polymeric coatings that are used to prevent the wool fiber from shrinkage, and their shrink-resist mechanisms are also be discussed.

## Structure and morphologies of wool fiber

The wool fiber is a keratin protein fiber containing 18 amino acids including glycine, alanine, tyrosine, lysine, glutamic acid, and cysteine and many of them have hydrophilic amino and carboxyl groups conferring wool fiber high moisture regain. The wool fiber has a porous structure and the air entrapped in these pores works as a heat insulator, providing woollen garments high warmth. Wool fibers are primarily composed of a core cellular component surrounded by an outer layer with cuticle cells as shown in Fig. 1. The core of wool fiber contains cortical cells arranged in an overlapping manner, which is elongated in the direction of the fiber axis. Cortical cells are composed of many macrofibrils and each macrofibril again is composed of many microfibrils. These microfibrils are made of aggregated keratin

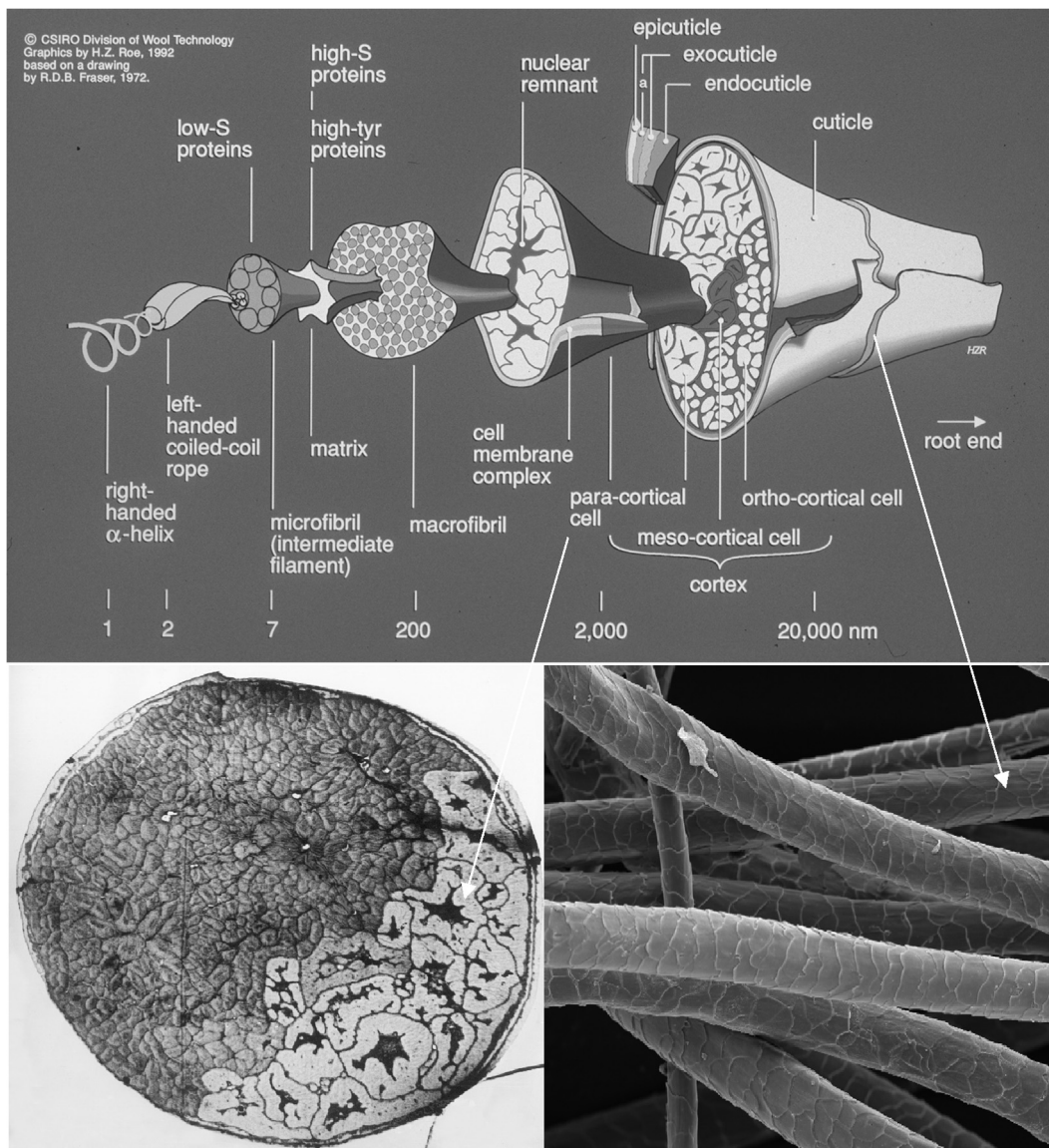

**Fig. 1.** Schematic diagram of internal structure of wool fiber (a) drawn by Bruce Fraser, Tom MacRae and colleagues [1], and also TEM image of cross-section (b) and SEM image of the surface (c) of wool fiber.

intermediate filament proteins ( $\alpha$ -keratin) surrounded by keratin-associated matrix proteins (KAPs) containing high levels of sulfur and tyrosine [3].

The microfibrils or intermediate filaments are composed of left-handed coiled coil ropes and each coil of the helix is connected by disulfide bonds. The disulfide bond network within the cortex of wool has a great influence on its physical and mechanical properties. The stability of wool fiber structure is governed by the type and extent of crosslinks between the intermediate filaments and the KAPs. The three-dimensional structures of keratin intermediate filaments and KAPs are made highly stable by intermolecular disulfide bridges and by intermolecular and intramolecular bonding of polar and non-polar amino acids [22]. The outer side of wool fibers has many cuticle cells having a lamellar structure and composed of an outer *exo*- and inner *endo*-cuticle layers. The *exo*-cuticle has an A-layer (the outermost layer) and a B-layer [3]. The A-layer is 30–60 nm thick and coated with a covalently bound 18-methyl eicosanoic acid (18-MEA) through thioester bonds providing wool fibers high water repellency [23]. The inner B-layer is considerably thicker (30–600 nm) than the outer A-layer, rich in disulfide linkages and isopeptide cross-links [24].

From a macromolecular point of view, wool fiber is an ‘all-protein’ composite fiber, where the filler (microfibrils) and the matrix polymer (cellular matrix protein) both are composed of chemically and physically interconnected polypeptides. The  $\alpha$ -helices in wool are present as coiled coils and grouped into rope-like structures with two, three or seven polypeptide strands [25]. The keratin filaments of wool and intermediate filaments are structurally homologous proteins. A three-chain structure has been proposed for the hard keratin from the  $\alpha$ -helical fragments isolated from the microfibrillar proteins of wool [26]. However, several studies of proteolytic fragments of wool suggest four-chain structure instead of a three-chain structure [27]. Further investigations of the  $\alpha$ -helix-rich particles prepared by chymotryptic digestion of the reduced and alkylated low sulfur proteins of wool suggest the formation of a pair of two-strand  $\alpha$ -helical coiled coils. The  $\alpha$ -helix is the secondary structure of the protein, which is created by folding of a single amino acid chain. Hydrogen and disulfide bonds formed between segments of the chain create this folded morphology as shown in Fig. 2. The formation of disulfide bonds gives these  $\alpha$ -helical coils rigidity increasing the stiffness of the fiber. If these disulfide bonds are broken,

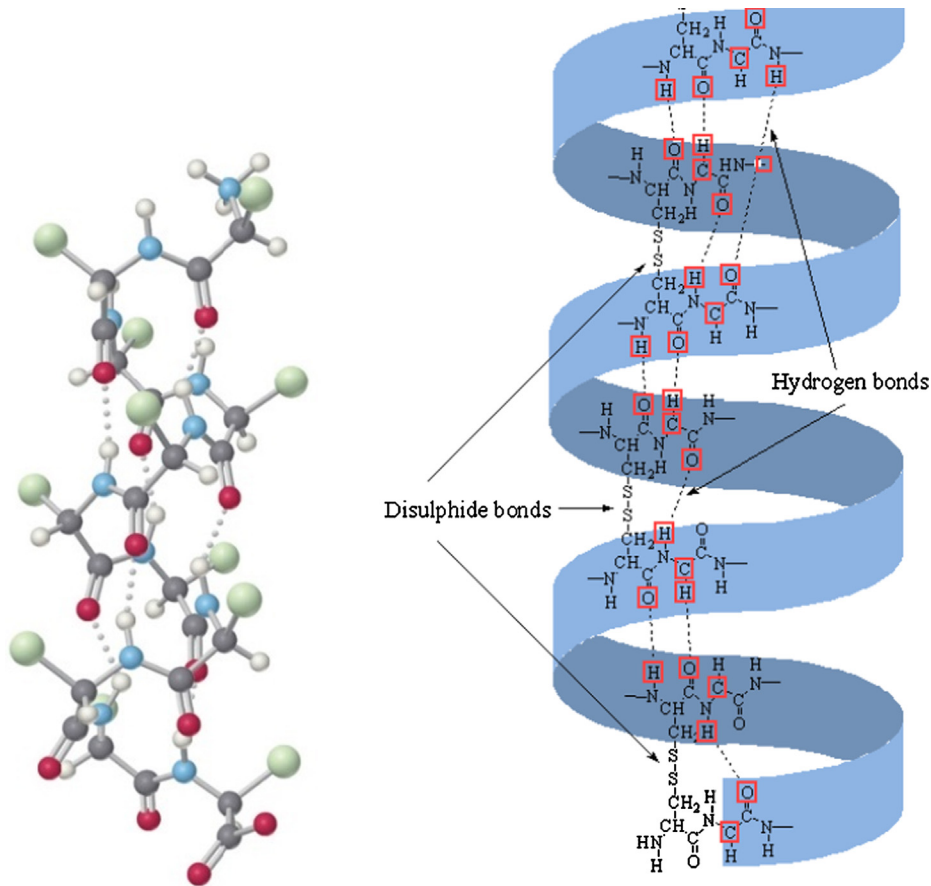

Fig. 2. The  $\alpha$ -helical structure of wool keratin.

the wool fiber behaves like a spring, which affects their dimensional stability.

### Shrinkage of wool fibers

The shrinkage of wool is a common phenomenon, which not only reduces the size of clothes but also incurs a great monetary loss for the consumers as the clothes become unusable. Wool fibers undergo two types of shrinkages, namely relaxation shrinkage, and felting shrinkage.

#### Relaxation shrinkage

The relaxation shrinkage occurs due to the release of strains/tensions, which are imposed during various stages of manufacturing of yarn or fabric by spinning, weaving, and knitting at various temperatures and humidity conditions. When the yarns and fabrics are removed from the machine and stored, they try to relax and go back to their original length. This kind of shrinkage is called relaxation shrinkage, which is reversible and occurs for textile materials made from any fiber. To overcome it, compressive shrinkage is given to wool fabric during decatizing so that it will no longer shrink during their use.

#### Felting shrinkage

The felting shrinkage occurs during wet processing, which is irreversible, i.e. once the shrinkage occurs, it is impossible to get back the original size of the fabric. The surface of wool fibers has many scales, which is responsible for the high shrinkage of wool

apparel during laundering. When the wool fabric is subjected to mechanical action in the presence of moisture, the individual wool fibers start to move. Because of the surface scales, the fibers can move only in one direction. During washing and/or tumble drying, under mechanical agitation, friction, and pressure in the presence of moisture and heat, the scale edge of one fiber locks into the inter-scale gap of another fiber like a 'ratchet' mechanism as shown in Fig. 3. The fibers interlock and cannot return to their orig-

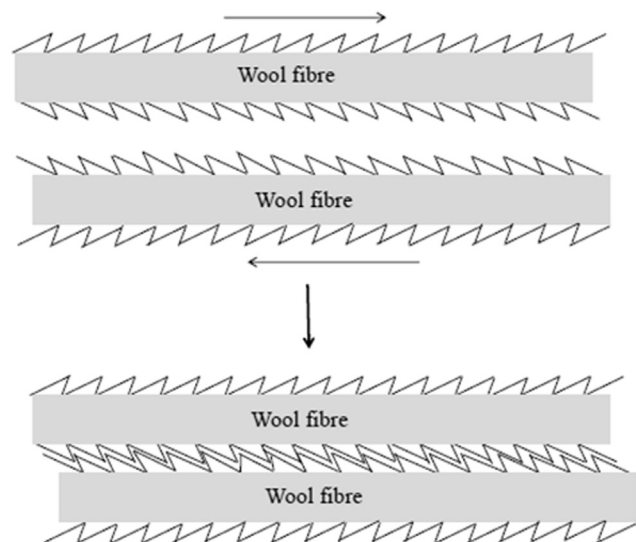

Fig. 3. Mechanism of felting shrinkage of wool.

inal positions resulting in irreversible felting shrinkage. Felting is advantageous for the fabrication of blankets and felted rugs but is a serious problem for apparel as it changes the appearance of the fabric [5]. The wool fibers can be made shrink-resistant either by removing or covering the scales or by restricting the movement of fibers in a fabric by binding them together.

### Shrink-resist treatments used in the wool industry

The traditional and commercially used shrink-resist treatments can be classified primarily into two groups, namely (i) chlorine-based treatments, and (ii) non-chlorine/AOX-free processes.

#### Chlorine-based shrink-resist treatments

Gaseous chlorine, sodium hypochlorite (NaOCl), and dichloroisocyanuric acid (DCCA) are used for the chlorination of wool tops, which removes the surface-bound 18-MEA from wool fibers and also etches the edge of wool fiber scales [7,10]. The removal of 18-MEA makes the fiber surface hydrophilic and compatible with various cationic resins. The most popular shrink-resist treatment for wool is the 'chlorine-Hercosett' process developed by the CSIRO (Australia). All chlorination treatment methods are more or less similar. The typical chlorine/Hercosett treatment can be carried out in a 5, 6, 7 or 8 suction drum bowls wool scouring machine. The first bowl is used for the chlorination treatment in the chlorine/Hercosett or DCCA/Hercosett process. Fig. 4 shows a typical chlorine-Hercosett treatment machine. Several machinery manufacturers including Andar Holdings Ltd (New Zealand) and Fleissner GmbH (Germany) make such a kind of machine. In the case of 5-bowl scouring machine, chlorine is added to the first bowl at pH lower than 2 at 20 °C and in the next bowls, metabisulfite is added to neutralize the residual chlorine.

In the case of hypochlorite, depending on the pH, chlorine, hypochlorous acid, and hypochlorite ions exist in equilibrium at a given pH value. At pH above 8.5, a diluted solution of sodium hypochlorite has hypochlorous ion ( $\text{OCl}^-$ ) but at pH 4.5–2.5 mainly undissociated hypochlorous acid (HOCl). At the pH below 2.5, chlorination of wool is carried out and at that pH, free chlorine accounts for approximately 70% of the total active chlorine. The third bowl is used for washing the chlorinated and neutralized fibers. If the neutralization is not carried out properly, it will affect Hercosett absorption causing uneven coating and also may cause yellowing of the fiber during drying. Hercosett at 1–2% owf is added in the fourth bowl at 30–35 °C and the pH of the bowl liquor is kept at 7.5 to 8.5 with the addition of sodium bicarbonate. In the last bowl, a silicone resin (0.2–0.3% owf) is added at pH 7.5 and the temperature of the bath is maintained at 40–45 °C. The last two bowls are always used for Hercosett and silicone treatment. The extra bowls are used in-between the chlorination treatment and

the anti-chlorination/neutralization treatment to wash the chlorinated wool. In the DCCA/Hercosett process, DCCA is used instead of NaOCl.

Kroy/Hercosett treatment is very similar to the chlorine/Hercosett treatment, except the chlorination is carried out by vertically immersing wool tops in the Kroy Deep Immersion chlorinator, which is a compact and closed loop chlorination system. The gaseous chlorine is injected into the Deep Immersion chlorinator, where the chlorine dissolves in water producing a mixture of hypochlorous acid (HOCl) and hydrochloric acid. The HOCl is responsible for the chlorination of wool. The degree of chlorination uniformity is vastly improved in this system compared to the chlorine-Hercosett treatment. Any unreacted chlorine gas coming out of the chlorinator is passed through a chlorine scrubber unit containing sodium hydroxide solution that converts chlorine to sodium chloride.

#### Synthesis of Hercosett resin and its reaction with wool fiber

The mechanism of synthesis of Hercosett 125 resin is shown in Fig. 5. Adipic acid is reacted with diethylenetriamine to form poly(diethyleneimino adipamide) through the condensation polymerization. This polydiethyleneimino adipamide is again reacted with epichlorohydrin to form poly(chloro-hydroxypropyldiethylene adipamide ammonium chloride), which is marketed as Hercosett 125 resin [28]. In the presence of an alkali, the chlorohydroxypropyl groups of this quaternary ammonium polyamide are converted into epoxy groups forming poly(epoxypropyldiethylene adipamide ammonium chloride) that can react with carboxyl and hydroxyl groups available in wool fiber surface as shown in Fig. 6.

#### AOX-free alternatives to the chlorine-based shrink-resist treatments

Because of poor environmental credentials of chlorine-based processes, various alternative treatments have been investigated. The sustainable alternative treatments developed and commercialized until recently are as follows:

#### PMS process

The PMS or Caro's acid with a formula of  $\text{HO-SO}_2\text{-OOH}$  is one of the strongest oxidants. Wool fibers are treated with 6–8% owf of PMS at pH 5–8 and then treated with a silicone resin (3–5% owf). An example of this process is the Dylan X process, but the treatment is not as effective as the chlorine-Hercosett process. It was reported that at least 9.0% owf of PMS is required to achieve an acceptable level shrink-resistance but that level of concentration causes considerable damage to the fiber [29].

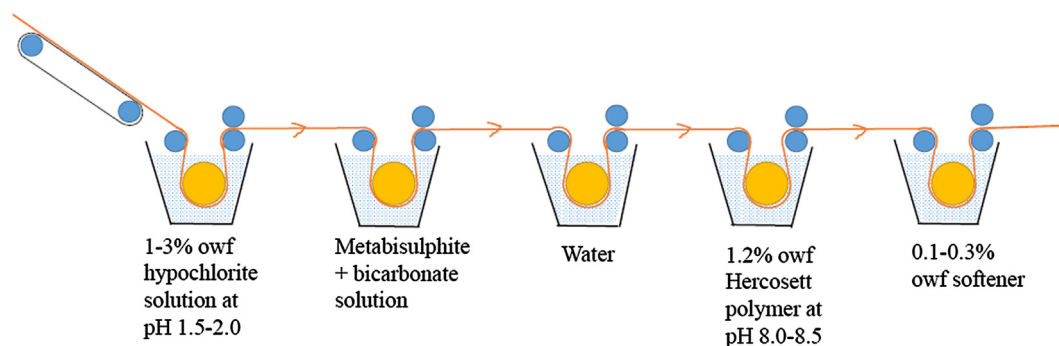

Fig. 4. Schematic diagram of chlorine-Hercosett shrink-resist treatment of wool top.

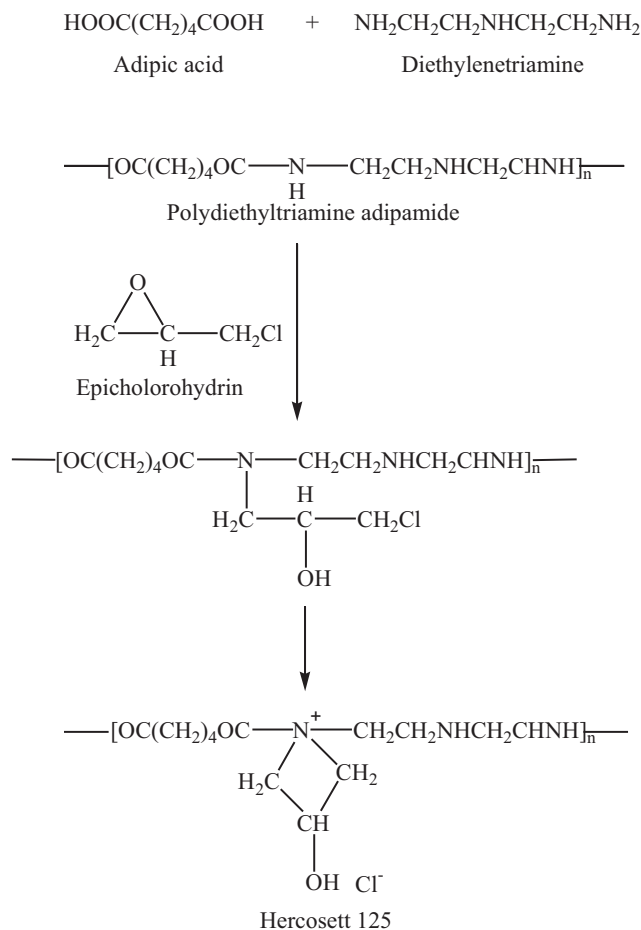

Fig. 5. Reaction mechanisms of formation of Hercosett resin.

#### Euro dye – CTC total easy care process

A Belgian company, EURO DYE – CTC, developed a shrink-resist treatment for woolen knitwear to make them machine-washable, which can be carried out in a paddle type or basket type garment dyeing machine. Wool knitwear is first scoured with a non-ionic surfactant (Crosteca LANA) and sodium bicarbonate at 40–45 °C for 15–20 min [30]. The fabric is then treated with the Crosteca Salt (possibly potassium salt of PMS) at the dosage of 3.0–7.0% owf at 20–35 °C for 20–30 min. The treated fabric is then treated with Costeca DEVE (a reducing agent) at pH 7.5–8.0 for 15–20 min to neutralize the residual reducing agent. In the next step, they are again treated with 4.0–5.0% owf a polymeric silicone resin (Crosteca FIT) at pH 6.0 at 30–35 °C for 30 min. The treated fabric shows less than 10% shrinkage as claimed by the company, which is still considerably higher than the shrinkage shown by the chlorine-Hercosett treated wool.

#### Perachem process

Lewis and Hawkes developed an AOX-free alternative of the chlorine-Hercosett process for the continuous treatment of wool tops known as Perachem Process commercialized by Perachem Limited [31]. In this process, the rapid removal of the hydrophobic lipid layer (18-MEA) is carried out by the treatment with a selective nucleophile/cationic surfactant system, which breaks down the thioester bonds producing hydrophilic wool fibers. The nucleophile used is permonosulfuric acid, which removes the 18-MEA from the surface of wool fibers. After the removal of 18-MEA, the

fibers are treated with the Hercosett resin, which still creates effluent containing AOX. The developed process is suitable for the continuous treatment of wool tops and is claimed to produce softer and whiter wool fibers compared to the chlorine-Hercosett treated wool.

#### Ozone and Ozone/Hercosett

Ozone ( $\text{O}_3$ ), an allotropic form of oxygen, is a very powerful oxidant with an oxidation potential of 2.8 V, which is only surpassed by fluorine (oxidation potential 3.5 V). In alkaline conditions,  $\text{O}_3$  produces hydroxyl radicals that can degrade wool fibers causing substantial strength loss. Therefore wool fibers are always treated with  $\text{O}_3$  in acidic conditions to minimize fiber damage. The half-life of ozone gas is very limited (less than a few minutes) and therefore ozone is needed to be generated on-site [32]. Moreover, ozone gas has very poor solubility in water and therefore spargers are used to enhance the transfer of ozone to water [33]. The chlorine-Hercosett treatment machine can be used for the ozone/Hercosett treatment of wool with some modifications. One of the advantages of  $\text{O}_3$  treatment is that it can etch the edge of cuticles like the chlorination treatment and the reaction is limited to the surface of the fiber without affecting the bulk properties and the dyeability of wool fibers. The continuous aqueous ozone treatment of wool fabric provided excellent shrink-resistance but the top treatment showed poor results [34,35]. The wool fabric treated with gaseous ozone at 70 °C also produced excellent shrink-resistance [36]. Choisnard et al. also carried out dry ozonation of wool fabric pre-treated with  $\text{H}_2\text{O}_2$  or alkali and found that the ozone treatment provided excellent shrink-resistance but needed a quite high concentration of ozone [37]. It is a sustainable alternative as ozone decomposes to oxygen. Several commercial wool apparel manufacturers including Patagonia use  $\text{O}_3$ /Hercosett treatment as an eco-friendly and sustainable shrink-resist treatment for wool.

#### Securlana K shrink-resist treatment

This treatment is an example of additive type shrink-resist treatment used for wool where instead of etching the scales, they are covered by a polymeric resin and the inter-fiber bonding limits the movement of the wool fiber during laundering. Henkel A.G. marketed this shrink-resist treatment for wool fabrics, which is first treated with a strong reducing agent (e.g. sodium sulfite) to break down some of the disulfide bonds to produce thiols. The fabric is then treated with a Bunte-salt terminated polyether (commercialized as Securlana K), that covers the wool fiber surface. After the exhaustion is complete, the pH is raised to the slightly alkaline side of the pH (8.0–8.5) so that the Bunte salt groups of Securlana K can react with the thiols groups of wool and covalently bind to wool fiber surface by forming disulfide bonds as shown in Fig. 7 [38].

Securlana K also can undergo self-crosslinking, forming a network structure by forming disulfide bonds. A high percentage of Securlana K (8–9% owf) is needed to get an acceptable level of shrink-resistance. It was reported that the Securlana treatment negatively affected the dyeability and the stain-resistance of the treated wool fabric [39].

#### Shrink-resist performance

Table 1 shows merits/demerits and comparative shrink-resist performance of wool treated by various conventional shrink-resist treatments. Of the conventional shrink-resist treatments, the PMS/silicone resin treatment provides the poorest shrink-resist performance as the shrinkage of the fabric increased from 1% after 1 × 5 A wash to 22% after 5 × 5 A washes [13]. Other

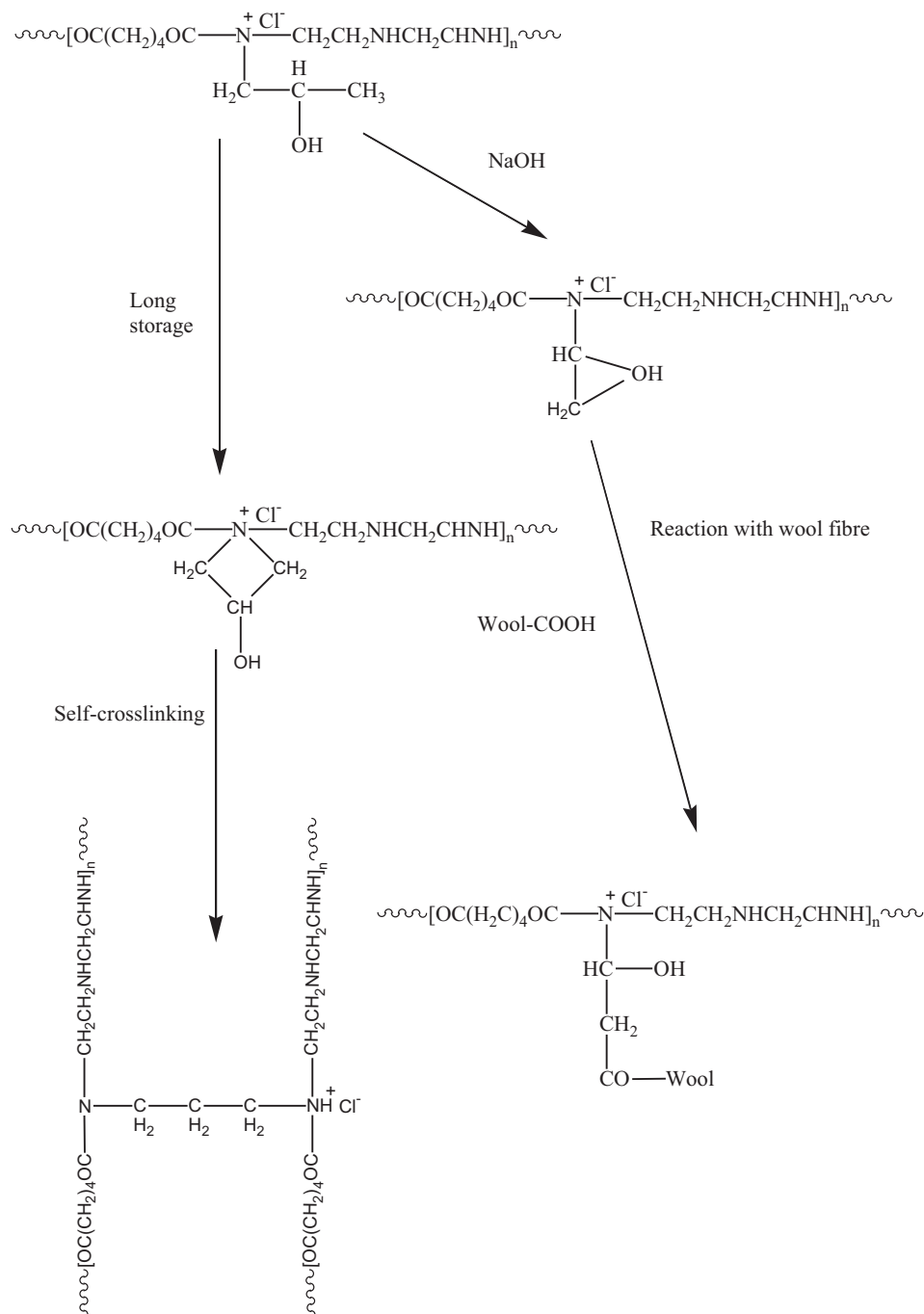

**Fig. 6.** Reaction mechanisms of Hercosett resin with wool fiber [7]. Reproduced with permission from John Wiley and Sons.

PMS-based treatments also provide similar shrink-resist performance [29]. On the other hand, the chlorine/Hercosett treatment provides the most durable and the best shrink-resist performance as after  $5 \times 5$  A washes the shrinkage of the fabric was only 0.5% [34]. Ozone/Hercosett also provided excellent shrink-resistance, near to the shrink-resistance provided by the chlorine/Hercosett process [34].

#### Merits and demerits

It is evident that the chlorine-Hercosett treatment is one of the most efficient shrink-resist treatments. The key advantages of chlorine-based treatments are low costs, high production speed, and the treatments can be carried out in continuous mode making

the process energy-efficient. Wool fibers can be treated in top form without any processing difficulty from top to fabrics. The Hercosett resin treatment of the chlorinated wool fibers without or in a combination with silicone resin increases their luster. Although the chlorine-based treatments provide highly effective and durable shrink-resistance, they decrease the strength as the surface scales are totally removed/etched, causes yellowing and also reduces the inherent stain-resistance of wool fibers [40]. The wool fibers are coated with a synthetic resin which affects the natural feeling of wool. All chlorine-based treatments are hazardous as they liberate chlorine gas to the environment and also produce effluent with residual chlorine, which may react with ammonia or amines forming chloramines (a carcinogen) harmful to aquatic animals as well as humans [41,42]. The alternative treatments developed up to

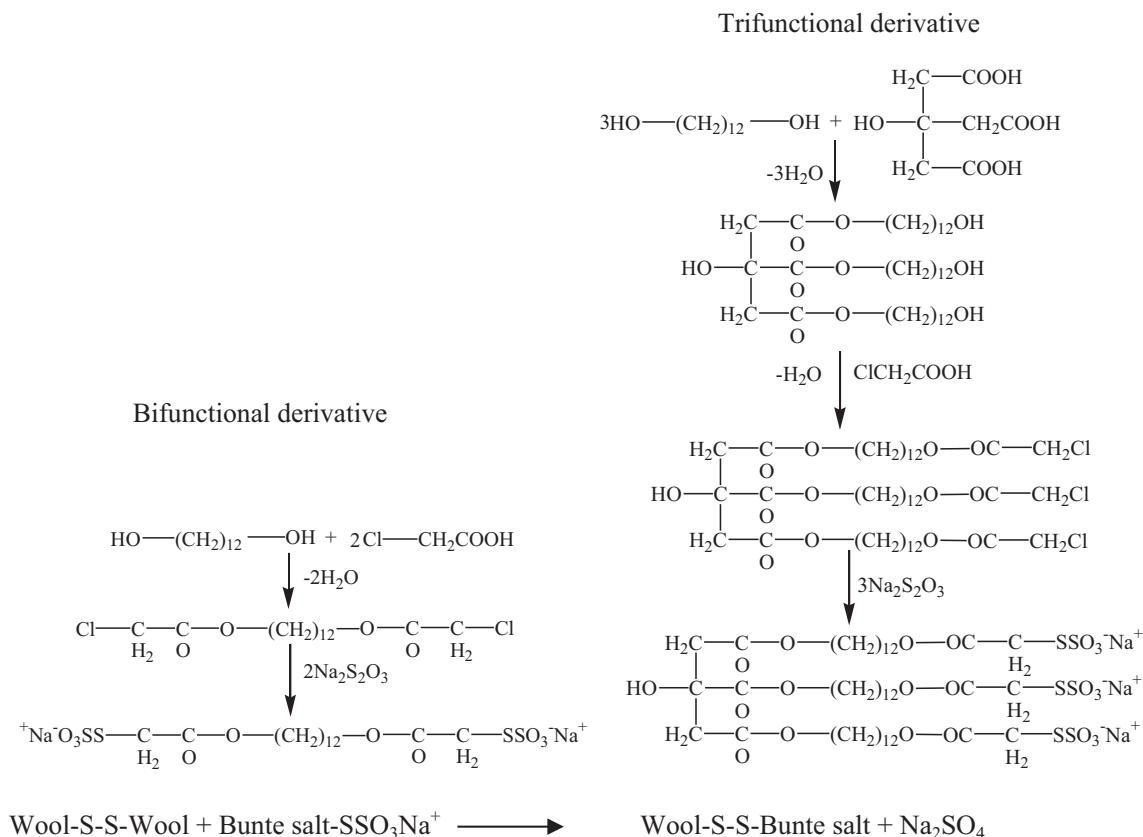

Fig. 7. The preparation of Bunte salt terminated polyether and its reaction with wool fiber [38]. Reproduced with permission from John Wiley and Sons.

now, such as PMS or Ozone-based treatments, are not as efficient as the chlorine-Hercosett process, only suitable for batch treatment, and the production speed is nowhere near to the production speed of the chlorine/Hercosett treatment. Of the AOX-free processes, only the production speed of the Ozone/Hercosett process could match the production speed of the chlorine/Hercosett process but the treatment cost is high and the shrink-resistance performance is also slightly inferior to the shrink-resistance provided by the chlorine-Hercosett treatment. On the other hand, the Securlana treatment method is only suitable for fabric treatment and the treated fabric has a soft handle but the high dosage of Securlana resin makes the surface of the fabric greasy, which is one of the reasons for its unsuccessful commercialization.

#### Advancements of sustainable alternatives

The recent advancements in the area of development of sustainable alternative shrink-resist treatments for wool have been concentrated on three areas: subtractive (partial or full removal of cuticles), additive (no removal of cuticles but fibers are bonded together), and a combination of subtractive and additive treatments. The additive treatments are only suitable for fabric-stage treatments.

#### Subtractive treatments based on partial/full removal of cuticles

##### Enzymatic treatments

Enzymes are proteins produced by living organisms that can catalyze various biochemical reactions. They are used in industry for various purposes, such as for the degradation of wastes into harmless compounds, for the cleaning of oil stains, and in fermenta-

tion processes to make alcohols [43,44]. Of them, protease enzymes can degrade proteins and this capability was investigated in wool processing to degrade scales of wool fibers to make them shrink-resist. The enzymatic shrink-resist treatments are a batch process and are quite slow. Wool fibers are treated with an aqueous solution of enzymes at a certain temperature and pH, which is selected based on the temperature and pH at which a particular enzyme shows stability and the highest activity. To enhance the shrink-resist performance, the enzyme treatment fibers/fabrics are further coated with a polymeric resin. The treatment with protease enzymes is usually carried out at mild alkaline conditions and at around 60 °C.

The enzyme can penetrate into the fiber causing considerable damage to the fiber. To overcome this problem, several methods, such as modification of enzyme with polymeric grafting and pre-treatment of wool with quaternary ammonium compounds, have been investigated [45–48]. Da Silva et al. modified the protease enzyme by covalently binding a copolymer of methyl methacrylate and methacrylic acid, a reversible soluble-insoluble polymer, by using a carbodiimide coupling agent to increase the molecular weight of the enzyme so that the protease enzyme cannot penetrate into the interior of wool fiber. The modified enzyme showed greater activity towards wool fibers compared to the native protease and reduced their weight loss during enzymatic treatment [45,46]. It was reported that the modification of subtilisin (a protease enzyme) by covalent binding with polyethylene glycol only hydrolyzed the outer cuticles of wool by limiting their penetration into the fiber [47].

##### Radiation treatments

Radiation is energy traveling in waves or particles that can excite molecules and atoms of a material to change their character-



**Table 1**

Various traditional oxidative treatments used in combination with polymeric coating for the shrink-resistance of wool fibers and their shrink-resist performance.

Treatment	Form of substrate	Mode of action	Method of treatment	Oxidant conc. (% owf)	Oxidation pH	Resin conc. (% owf)	Shrinkage (%)	Merits	Demerits	Ref.
<i>Chlorine-based treatments</i>										
Chlorine-Hercosett	Top	Chlorination with a NaOCl solution followed by the treatment with Hercosett and a softener	Continuous	1.0–2.0	1.5–2.0	2.0 (Hercosett) and 0.2 to 0.3 (softener)	0.5 to –1.2% after 5 × 5 A washes	1. The cheapest and one of the most effective shrink-resist processes	1. Needs neutralization and antichlorination with sodium metabisulfite. 2. Causes yellowness of fiber and 2% weight loss 3. AOX in the produced effluent.	[4,34]
Kroy/Hercosett process	Top	Vertical and deep immersion in aqueous chlorine and then with Hercosett resin	Continuous	1.0–3.0	2.0–2.5	1.0–2.0	Similar to chlorine-Hercosett treatment	1. Produces even treatment 2. Does not need neutralization and anti-chlorination	1. Produces AOX in the produced effluent. 2. Residual chlorine in the treated fiber. 3. Chlorine gas is released to air if no scrubber unit is used.	[7]
DCCA-Hercosett	Fabric	Chlorination with DCCA and then coated with Hercosett resin	Batch	2.0–3.0	3.0	2.0	2.0% after one wash	1. Less risky to handle than direct chlorination treatment	1. Comparatively expensive than the chlorine-Hercosett process. 2. Causes uneven treatment 3. Increases fiber rigidity and yellowness. 4. Produces AOX in the effluent.	[8]
Basolan DC/silicone resin	Top	Chlorination with DCCA and then coated with Hercosett resin	Batch	2.5–4.5	4.0–5.0	2.0–3.0	Comparatively poor compared to DCCA/Hercosett treatment	1. Less risky to handle than direct chlorination treatment	1. It has demerits similar to DCCA treatment.	[11]
<i>Sustainable alternatives</i>										
PMS/silicone resin	Top	Oxidation with PMS and then resin treatment with cationic silicone resin	Batch	6.0–8.0	5–8	3.0–5.0	Poor shrink-resistance, 1% after 1 × 5 A wash to 22% after 5 × 5 A wash	1. Good color and soft handle	1. Not as effective as the chlorine-Hercosett process or DCCA/Hercosett treatment. 2. Poor cohesion between fibers causing processing difficulty	[13]
Dylan X Process	Top	Oxidation with possibly with PMS and then treated with a silicone resin	Continuous	11.0	n/a	n/a	Similar to PMS/silicone process	1. Chlorine-free treatment 2. No AOX in the effluent	Similar to the PMS/silicone treatment.	[29]
Ozone/Hercosett	Top	Continuous	Continuous	1.0–2.0	1.7	2.0– 3.0	1.5% after 5 × 5 A washes	1. Chlorine-free treatment 2. No AOX in the effluent 3. Does not affect the wash fastness of the dyed materials	1. Comparatively expensive than any commercial shrink-resist treatment. 2. Not as effective as the chlorine-Hercosett process.	[34]

istics. Various types of radiations, such as ultraviolet, gamma, X-ray, infrared, and radio wave, are used for the chemical modification of fibers and polymers. Of them, UV radiation mainly has been investigated to make wool fiber shrink resistant. Radiation ionizes or excites the atoms or molecules in fibers and produces hydroxyl radicals that can cause degradation in the macromolecular chains. Radiation-based shrink-resistance treatments are envisaged as an eco-friendly process as they do not produce any effluent and it is virtually a dry treatment other than the post-radiation coating of wool fibers with a polymer. Primarily, UV radiation treatment, especially at UV-A region, is used to make wool fiber shrink-resistant.

#### Plasma treatments

Plasma treatments are dubbed as a sustainable shrink resist treatment as they do not produce any effluent [48]. Plasma is the fourth state of matter as matter in that state has properties dissimilar to its solid, liquid or gaseous state. It is a mixture of partially ionized gas that is generated by an electrical discharge. When gas molecules are excited by a high voltage discharge, they dissociate into negatively charged electrons and positively charged ions producing plasma. Although monomeric gasses including organosilanes and fluorocarbons have been investigated for hydrophobic and oleophobic coating of textiles [49,50], only non-monomeric gasses (air, oxygen, argon, etc.) have been investigated to make wool fabric shrink-resistant [51,52]. In plasma treatment, scales of individual fibers are affected rather than just the surface of the fabric. The plasma generators can be classified into two categories namely (i) low-pressure plasma, and (ii) atmospheric pressure plasma. Both types of plasma treatments were investigated for the shrink-resistance of wool. The atmospheric plasma process is advantageous over low-pressure plasma as the treatment could be carried out in the continuous mode. Corona and barrier discharge plasma systems fall under this category.

Depending on the mechanisms used for the plasma generation, plasma generators can be classified into corona discharge, dielectric barrier discharge, arc discharge, glow discharge, radio frequency, and microwave plasma. Of them, corona discharge, dielectric barrier discharge, and radio frequency plasma have been

mainly investigated to impart shrink-resistance to wool fiber. In the corona plasma treatment, the machine is composed of two sections, a corona generator, and the treatment chamber as shown in Fig. 8 [51]. The corona generator produces a high frequency (up to 35 kHz) output, which is fed to the treatment station, where it is stepped by a transformer to a voltage ( $10^4$ – $10^5$  V) high enough to ionize the gas in between the electrodes. The corona discharge takes place in the treatment chamber in between two rollers (work as an electrode) through which the fabric is passed. The rollers are coated with dielectric silicone rubber, which produces gentle plasma suitable for textile materials. One of the electrodes is attached to the corona generator and the other to the ground. Owing to the short time of the pulses, the corona discharge is strongly non-equilibrium in terms of temperature and plasma density. The pulse is used to control the build-up of heat, which may transform the plasma to arc discharge.

The corona discharge treatment was one of the earliest plasma treatments investigated for the shrink-resistance of wool fibers and it was found that 5–10 s treatment reduced the felting shrinkage to –4.5 to –8.0%, which increased to 4.6 to 0% after four washes [52]. Plasma and corona treatments not only etch the surface of wool fiber by oxidation but also generate chemically active species that react with the fiber surface forming hydrophilic groups [53,54]. Plasma creates a high density of free radicals by dissociating molecules through the collision of electrons and the photochemical process, causing the disruption of the chemical bonds in the fiber surface. Plasma treatments greatly modify the surface topography and the surface chemistry of the fiber surface [55]. Both low pressure and atmospheric pressure plasma technologies have been investigated to make wool fiber shrink-resist but the latter process could be better suitable than the former for the continuous treatment of wool [56–58].

However, low-pressure plasma treats the substrate more evenly and covers a wider area than the atmospheric pressure plasma. The application of low-pressure plasma technologies has been extensively investigated for wool fibers to improve their shrink-resistance [59]. When wool fibers are plasma treated in the presence of non-polymerizing gases, such as oxygen, air, or nitrogen, 30–50 nm depth of the outer layer of the wool fiber is modified by etching and also by the removal of the bound fatty acid lipids

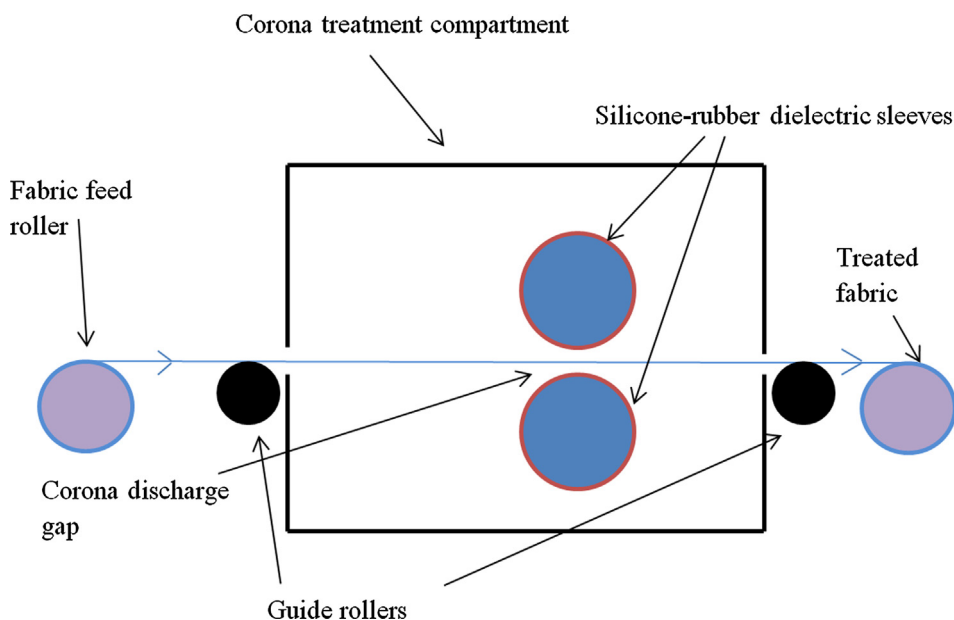

Fig. 8. Schematic diagram of Corona-based plasma treatment equipment used for the shrink-resist treatment of wool fabrics [51]. Reproduced with permission from the American Chemical Society.

including 18-MEA [60]. The plasma treatment produces hydroxyl and carboxyl groups on the surface of wool making the surface hydrophilic [51]. It was reported that the hygral expansion decreased with an increase in the severity of the corona intensity [61]. The investigation of low-temperature argon and helium plasma treatment confirmed that it could provide excellent shrink-resistance and the treatment was durable to laundering [62].

#### *Shrink-resist performance*

By damaging only the cuticles, it is difficult to provide effective and durable shrink-resistance. Table 2 shows the list of various shrink-resist treatments based-on full or partial removal of cuticles by oxidation treatments that have been studied. Bromelain at only 2% owf showed excellent shrink-resistance but the cost of bromelain could be an issue [15]. Alkaline peroxide [63], dicyandiamide (DD)-activated peroxide treatments [64], and also activated peroxide along with enzymatic treatment with a protease [65], showed very good shrink-resist performance. DD-activated peroxide treatment followed by the treatment with protease gave excellent shrink-resistance [64]. Levene and Cohen investigated one-step oxidation of wool fabric with magnesium monoperoxyphthalic acid (MMPP) at an acidic pH and found that at the applied concentration of 3.0–6.0% owf provided excellent shrink-resistance [28]. Ozone alone or ozone/bisulfite treatment was found ineffective at providing durable shrink-resistance to wool fibers [65]. However, the treatment increased fiber yellowness and also caused uneven treatment. The combined radio-frequency plasma and protease enzyme treated wool fabric showed excellent shrink-resistance but not without substantial fiber damage [66]. Although some of them were found effective, all of these processes are very slow for industrial application together with an increased energy cost.

#### *Merits and demerits*

The enzymatic treatments are environmentally friendly but the speed of production is very slow as the treatments can only be carried out in batches. The slow reaction of the enzymes makes them unsuitable for continuous treatment. The enzymatic reaction with wool is unpredictable as some fibers may remain totally unaffected by the enzymes and some fibers may be over-treated causing severe damage to the fiber as evident in Fig. 9. The enzyme can penetrate into the fiber causing considerable damage to the fiber.

On the other hand, the UV radiation treatment is a continuous but dry process producing no effluent. However, it damages wool fiber and can cause severe yellowing of the fiber [67]. Oxidative plasma treatments could be a batch or continuous process and etch the surface cuticles of wool fibers resulting in severe damage of the fiber. These processes alone provide only some levels of shrink-resistance but do not provide durable shrink resistance desired by the industry or consumers.

#### *Additive shrink-resist treatments*

These methods have been developed for the treatment of wool fabrics but they are unsuitable for loose wool fiber treatment. In this method, no damage of cuticles of wool takes place and therefore hardly any damage to the wool fibers occurs. Wool fibers are coated with a fiber-reactive or a crosslink forming polymer that binds the fiber and also covers the inter-scale gaps limiting their movement and prevents from interlocking during laundering. The typical process is a pad-dry-cure method, where dispersion/solution of polymers is added to the padding mangle and the fabric to be treated is passed through the emulsion/solution. The fabric is then dried and cured whenever a fiber-reactive polymeric resin

is used. Both synthetic resins and also modified bio-based polymers have been investigated to cover the scales of the wool fiber surface.

#### *Synthetic polymeric coatings*

A range of crosslink forming polymeric resins, such as, polybutadiene [68], polyurethane containing free isocyanate groups (Synthapret LKF) [69], polyurethane with bisulfite adduct (Synthapret BAP) [70], Bunte-salt terminated polyether (Lankrolan SHR3) [71], polythiols [72], polyamides by interfacial polymerization [73], polydimethylsiloxane diols in combination with an amino functional silane crosslinking agent [74], diacrylates [75], have been investigated to form polymeric coating on wool fiber. Cook and Fleischfresser reported that wool fabrics coated with bisulfite-adduct named Synthapret BAP at 3.0% owf provided excellent shrink-resistance but considerably affected the handle properties of the treated fabric [70]. Hercosett resin alone has also been investigated to cover the scales of wool to impart shrink-resistance but failed to provide any shrink-resistance [76]. Ume-hara et al. used glycerol polyglycidyl ether (GPE) to crosslink the epicuticles of wool fiber in wool yarns to make them shrink-resistant [77]. Reactive aliphatic diisocyanate also has been investigated to cover the scales of wool fiber and it was found that the dibutyltin dilaurate (DBTL)-catalyzed hexamethylenediamine diisocyanate (HMDI) and triethylenetetramine (TETA) combination treatment provided the best shrink-resistance [78].

Recently Toabo Corporation, Sotoh Co. Ltd., and Moriyasu Dye Works Co. Limited of Japan together developed a chlorine-free shrink-resist treatment for wool called 'Life Fiber Eco-friendly Treatment' [79]. In the first step, wool fibers are treated with an aqueous solution of a diamine (e.g. hexamethylene diamine) and in the next step, treated with a diacid chloride (e.g. sebacoyl chloride) dissolved in a water-immiscible solvent. A polyamide polymer coating is formed at the interface of the two liquid phases through interfacial condensation polymerization, which is similar to the process developed by Whitfield et al. [73]. The key advantage is the very low energy consumption for the treatment and also the absence of damage to the outer layer of wool. However, harmful solvents need to be used and no attachment of the formed polyamide layer to the wool fiber surface takes place other than the hydrophobic-hydrophobic interaction unlike chlorine/Hercosett treatment. Therefore, these treatments may not provide long-term durability and may be removed by abrasion during their use. Dodd and Carr used UV radiation for the curing of the polymeric coating to make wool fabric shrink-resist, which severely affected the handle properties of the fabric [80].

#### *Bio-based polymeric coatings*

Several bio-based polymers, such as collagen, chitosan, and polypeptides extracted from wool protein fibers using the serine-type protease Esperase 8.0L, have been investigated to provide shrink-resistance to wool fibers [81–83]. These biopolymers can bind to the amino groups of wool fiber by ionic bonding. For example, chitosan can be ionically bonded to the surface of the wool fabric as shown in Fig. 10, where the amino groups of chitosan ionically bind to the carboxyl groups of wool fiber. The hydroxyl groups also can form hydrogen bonding with the amino groups of wool fiber. The extracted polypeptides can also be covalently bonded to the surface of wool fiber by using a crosslinking agent (glycerol diglycidyl ether or GDE) to form a cross-linked coating on the fiber surface of the wool fiber. The treated wool fabric maintained 1–2% shrinkage after five Woolmark 5A launderings. Several researchers investigated the effect of chitosan coating on the shrink-resistance of wool fibers [84–86]. They used a single-step

**Table 2**  
Shrink-resistance treatments based on the partial or full removal of wool fiber scales and their shrink-resist performance.

Treatment	Form of substrate	Mode of action	Oxidant conc. (% owf)	Oxidation pH	Treatment temperature (°C)	Time (min)	Method of treatment	Test method	Shrinkage (%)	Merits	Demerits	Ref.
DCCA/H <sub>2</sub> O <sub>2</sub>	Fabric	Two-step DCCA treatment with gluconic acid (GA) followed by the H <sub>2</sub> O <sub>2</sub> treatment with GA	n/a	4.1	20	60 min	Batch	Woolmark TM 17	–1.60%	1. No AOX in the process effluent 2. Excellent shrink-resistance	1. AOX in the effluent	[9,10]
Bromelain	Woven fabric	Partial or full cuticle damage	2.0	5.5	60	75	Batch	Woolmark TM 31	1.8% after 0 wash and 4.3 after 5 washes	1. AOX-free, food-grade enzyme 2. Comparatively mild action on wool compared to protease.	1. The enzyme is very expensive. 2. Slow process.	[15]
Lipase, SMPP, sodium sulfite and papain	Top	3 step treatment with lipase, SMPT and sulfite and then with papain	0.2 lipase/5.0 SMPP/0.25 papain	8.0/2.8–3/7.0	35/30/50	60/30/60	Batch	Woolmark TM 31	0.9 after 3 × 5 A and 1.1 after 5 × 5 A washes	1. No AOX in the process effluent and excellent shrink resistance	1. The process is slow and expensive.	[18]
Cutinase and protease	Fabric	2-step Cutinase (from <i>Thermobifida fusca</i> WSH04) treatment followed by protease treatment	Cutinase 10.0 U/g fabric/ Protease 250 U/g fabric	8.0/9.5	60/55	240/60	Batch	Woolmark TM 31	4.0% after 1 × 5 A wash	1. AOX-free and highly effective	2. Difficult to control the reaction 2. Slow process.	[19]
MMPP	Fabric	One step oxidation with MMPP	3.0–6.0%	4.5–6.5	n/a	n/a	Batch	Woolmark TM 17	0%	1. No AOX in the process effluent 2. Excellent shrink-resistance	1. Can cause uneven treatment 2. Increases fiber rigidity and yellowness	[29]
PMS	Top	One step oxidation with PSA	9.0	7.5–8.0	30	n/a	Batch	Woolmark TM 17	2%	No AOX in the process effluent	1. Can cause uneven treatment 2. Increases fiber rigidity and yellowness	[29]
Ozone and bisulfite	Fabric	Ozonation followed by reduction with bisulfite	1.56	1.7	80	10	Continuous	Woolmark TM 17	13.70%	1. AOX-free and no harmful oxidation product	1. Safety issues 2. Poor shrink-resistance	[34]
Modified protease	Fabric	Esperase (protease) was modified with Eudragit S100 to limit enzyme absorption into the fiber	5.0 U/g fabric	n/a	50	60–120	Batch	Woolmark TM 31	0.3 after 1 × 5 A	1. Excellent shrink-resistance. 2. AOX-free. 3. Less fiber damage compared to unmodified protease.	1. The process is slow and expensive.	[46]
Plasma only	Fabric	Single-stage plasma treatment	50, 100, 150 W	n/a	n/a	60 s	Batch	AATCC TM 99	4.1%, 4.2%, 3.5%	1. Excellent shrink-resistance. 2. AOX-free.	1. Damages the fiber	[52]
Alkaline H <sub>2</sub> O <sub>2</sub> /protease (Esperase 8.0 L)	Fabric	Two step alkaline peroxide followed by protease treatment	20 ml/l/2.0 Protease	11.4–12.2	30 /45	20/40	Batch	AATCC TM 135	5.16%	1. Good shrink-resistance 2. Chlorine-free	1. May cause degradation of fiber	[63]

Activated H <sub>2</sub> O <sub>2</sub>	Single jersey knot	Two-step DD-activated treatment followed by the treatment with Esperase (protease)	12 ml/l H <sub>2</sub> O <sub>2</sub> (50%) + 3 g/l DD/1.5% owf Esperase	11.5/8.5	40/80	45 min/10 min	Batch	Woolmark TM 17	0 after 5 × 5 A wash	1. No AOX in the process effluent 2. Excellent shrink-resistance	1. The process is slow [64]
Dicyandiamide (DD) activated alkaline H <sub>2</sub> O <sub>2</sub> /protease (Esperase 8.0 L)	Fabric	Two step DD-activated alkaline peroxide followed by protease treatment	20 ml/l H <sub>2</sub> O <sub>2</sub> + 3 g/l DD/2.0 Protease	11.4–12.2	30 /45	40/40	Batch	AATCC TM 135	–0.86%	1. Excellent shrink-resistance 2. Chlorine-free	1. May cause degradation of fiber [64]
Plasma and enzyme	Fabric	Plasma treatment (13.56 RF plasma)/water vapor followed by enzymatic treatment with protease	100 W/1.0–4.0	n/a	n/a	45 s/15 min	Batch	Woolmark TM 31	11.6%–3.4% after 2 × 5 A washes	1. AOX-free	1. The process is slow and expensive 2. Poor shrink-resistance. [66]

treatment using chitosan alone and cyanuric chloride modified chitosan, and also a two-step treatment with chitosan followed by crosslinking with citric acid, or polyurethane that substantially improved the shrink-resistance of the wool fabric [86,87]. On the other hand, Yang et al used nano chitosan, low molecular weight chitosan, and normal chitosan [88]. They found that nanochitosan-treated wool fabric showed better shrink-resistance and antibacterial properties compared to the wool fabric treated with either low molecular weight chitosan or normal chitosan.

Coating of wool fibers with protease extracted feather keratin crosslinked with GDE has been investigated for the shrink-resistance of wool [89]. The feather keratin coated wool fabric showed excellent anti-felting and shrink-resist properties. Cardamone and Martin used keratin hydrolysates to cover the scales of wool fiber by using transglutaminase as a cross-linker, and found that keratin hydrolysate or transglutaminase alone not only increases tensile strength but also shrink-resistance [90]. However, the combined treatment of keratin hydrolysate and transglutaminase shows better improvement in tensile strength and shrink-resistance than either one of them alone.

#### Shrink-resist performance of polymer-coated wool

Table 3 shows various polymeric treatments investigated to cover the scales of wool fiber to limit their shrinkage during laundering. Of them, the reactive aliphatic diisocyanates in a combination with various diamines and also the keratin hydrolysate-coated wool fabrics showed the lowest shrinkage [91]. Diacrylate and Herculon provided very poor shrink-resistance. None of the treatments showed the level of shrink-resistance desired by the wool industry.

#### Merits and demerits of polymer coating-based treatments

Just coating wool fibers without any bonding with the fiber surface can temporarily make wool shrink-resist but the coatings will break down due to abrasion encountered in their daily use. Without the removal of the 18-MEA fatty acid layer, it is difficult to bind any polymer to the wool fiber surface and it is also difficult to produce a uniform coating as hydrophilic polymers will not evenly spread on the hydrophobic wool fiber surface without increasing the interfacial adhesion between the fiber surface and the polymeric resins. Moreover, the thickness of the coating and the levels of add-on required to cover the scales considerably affects the handle properties of the treated fabric. Moreover, the coating of wool fibers with synthetic polymers may affect their biodegradability. Therefore, the polymeric coating alone may not be a viable shrink-resist treatment for wool.

#### Shrink resist treatments based on a combination of subtractive and additive methods

In these types of treatments, cuticles of wool fibers are partially or fully removed, 18-MEA is removed and the surface modified wool fibers are then coated with a suitable polymeric resin. The removal of 18-MEA improves the adhesion and spreading of aqueous-based polymeric resin dispersions, forming uniform coatings on the fiber surface. These treatments can be classified into the following categories:

#### Oxidative treatments followed by coating with synthetic polymers

In this area, the emphasis is given on two-stage plasma treatments for etching the scale edges and also removing the 18-MEA layer fully or partially and then coating the treated fabric with a

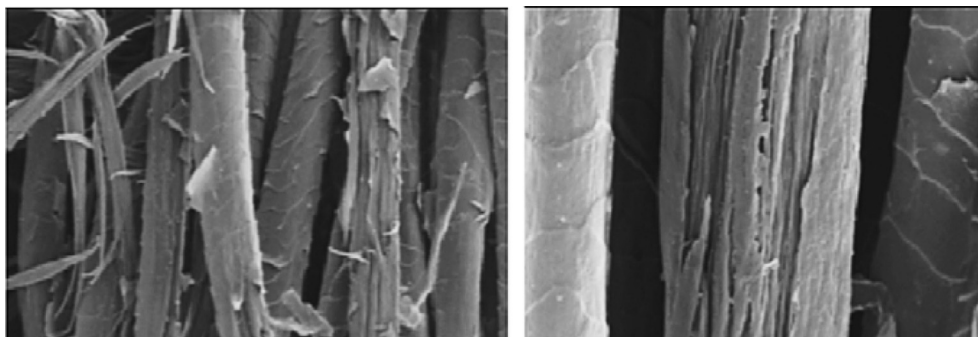

Fig. 9. Uneven treatment caused by the unmodified (left) and Eudragit S100-immobilized (right) protease enzyme [46]. Reproduced with permission from Taylor & Francis.

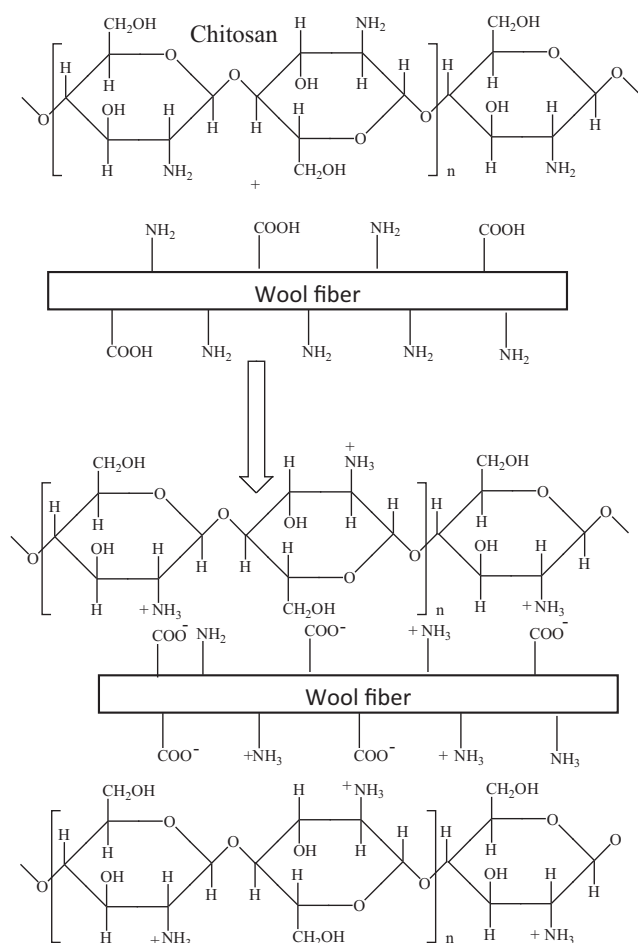

Fig. 10. Mechanism of binding of chitosan to the surface of the wool fiber.

polymeric resin. Millard et al. first investigated the two-stage plasma treatment in a combination with a fluorocarbon treatment as a chlorine-free shrink-resist treatment for wool [92]. Wool yarns were soaked in a fluorocarbon modified acrylic acid monomer and then plasma treated. The combined treatment only offered 9–12% shrinkage and the durability of the treatment to washing was not investigated. Single stage plasma coating of wool using tetrafluoroethylene and hexafluoropropylene has been investigated to make wool fabric shrink-resist as well as water repellent [93]. The tetrafluoroethylene/plasma treated fabric showed excellent shrink-resistance compared to the hexafluoropropylene treatment but they may affect the dyeability of the treated fabric. The treatment time is also quite long (30 min) to achieve an acceptable level

of shrink-resistance. The oxidative treatments investigated were mainly enzymatic and plasma treatments followed by coating with synthetic polymers. Recently the pre-treatment of wool fibers with a protease enzyme followed by coating the wool fibers with alkoxysilanes [e.g. (3-glycidyoxypropyl)trimethoxysilane, and (3-mercaptopropyl)trimethoxysilane] by sol-gel treatment have been investigated as a means to make wool fabric shrink-resist, which provided excellent shrink-resistance without considerably affecting the handle properties of the fabric [91]. The (3-mercaptopropyl)trimethoxysilane treatment provided marginally better shrink-resistance than the other alkoxysilane. The sol-gel coating will need to be carried out after the dyeing as the coating may affect the dyeability of the fabric. Several researchers reported that the pre-treatment of wool fabric with a protease enzyme followed by the coating with the chitosan polymer or fluorocarbon resin provided excellent shrink-resistance [94,95].

Glow discharge plasma in conjunction with Basolan MW has been investigated for shrink-resistance of wool with good success [96]. Naebe et al. investigated a short time (1–3 s) atmospheric plasma treatment followed by the treatment with 5% owf amino-functional poly(dimethylsiloxane) [97]. Kim and Kang investigated the effect of plasma intensity on the shrink-resist performance of wool fabric coated with an amino-functional silicone polymer after the plasma treatment, which provided excellent shrink-resistance [98]. It has been reported that the ethanol-based micellar system of Hercosett/H<sub>2</sub>O<sub>2</sub> treatment using sodium dodecyl sulfate as an emulsifier made wool shrink-resist [99]. The UV radiation treatment followed by coating with Synthappret BAP provided good shrink-resistance (8%) but affected the handle properties of the treated fabric. Demir et al. investigated argon plasma treatment in a combination with chitosan coating and also in a combination with protease enzyme and chitosan coating that provided quite good shrink-resistance to knitted wool fabrics [100].

#### Oxidative treatments in combination with a coating of wool with bio-based polymers

Gupta and Natarajan used UV radiation at 172 nm wavelength for five minutes to remove 18-MEA from wool and then coated the fiber with sericin at 5 g/l, which reduced the shrinkage to zero and did not affect the handle properties of wool [20]. Rahmatinejad et al. investigated a two-step dry state UV/O<sub>3</sub> treatment of wool fabric followed by coating with a fluorocarbon polymer to impart shrink-resistance [101]. Although the treatment provided durable and excellent shrink-resistance, the fluorocarbon treatment may affect the dyeability of wool. Jin et al. investigated a two-stage high powered inductively coupled 13.56 MHz radio frequency plasma treatment followed by the treatment with chitosan [102]. It was reported that two-step alkaline peroxide treatment and then coating with chitosan was unsuccessful as the shrinkage of the treated

**Table 3**  
Shrink-resist treatments based on covering the inter-scale spaces with a polymeric resin and their shrink-resist performance.

Treatment	Form of substrate	Mode of action	Resin conc. (% owf)	Method of treatment	Test Method	Shrinkage (%)	Merits	Demerits	Ref.
Siolan BAP	Fabric	Coating wool with a bisulfite-adduct named Synthapret BAP	3.0	Batch	Woolmark TM 185	10.0 after 17 washes	1. Cheap and easy chlorine-free process	1. Affects the handle properties 2. Not that effective	[70]
Diacrylates	Fabric	Coating of wool fiber by reacting with a diacrylate containing glycidyl groups by click chemistry	10.0	Batch	Woolmark TM 31	6.0 to 25.0	1. Chlorine-free and oxidation-free	1. Expensive and not robust 2. Affects the handle, the catalyst used for the quick reaction is highly expensive	[75]
Hercosett	Fabric	Coating wool fiber with Hercosett	n/a	Batch	Woolmark TM 185	Poor	1. AOX-free treatment.	1. Provides some level of anti-felting properties 2. No shrink-resistance	[76]
GPE	Yarn	Coating of wool fibers with a one-step treatment with GPE	5% GPE (w/v)	Batch	Woolmark TM 31	3.85 after 1 × 5 A wash and 11.5% after 3 washes	1. Simple AOX-free process	1. Not effective and may affect the handle	[77]
Reactive aliphatic diisocyanates with various diamines	Fabric	Scoured with perchloroethylene and then coating wool fiber scales with HMDI + TETA	0.13% HMDI + 2.00% TETA + 0.02% DBTL	Batch	Woolmark TM 185	6.3	1. Simple AOX-free process	1. Not effective and may affect the handle	[78]
Reactive aliphatic diisocyanates with various diamines	Fabric	Alkaline scouring at pH 10.6 followed by coating wool fiber with HMDI + TETA	0.10% HMDI + 2.00% TETA + 0.02% DBTL	Batch	Woolmark TM 185	4.8	1. Simple AOX-free process	1. Not effective and may affect the handle	[78]
Protease-extracted polypeptides	Fabric	polypeptides were extracted from wool by protease was applied on wool fabric and crosslinked with GDE	Peptide conc. is not mentioned but GDE conc. was 10 g/l at 7.3 pH at 60 °C	Batch	Woolmark TM 31	5.6 after 3 × 5 A washes	1. Simple chlorine-free process	1. May affect the handle and also the dyeability of wool	[83]
Keratin hydrolysate	Knitted	Covering scales of wool with silver nanoparticle-containing keratin hydrolysate crosslinked with transglutaminase	8.0 (keratin)/6.0 (transglutaminase)	Batch	Woolmark TM 31	5.0	1. AOX-free treatment. 2. Increases the strength of the fabric	1. Costly treatment. May affect the handle 2. May not show the long-term durability of the chlorine-Hercosett process.	[90]
Keratin hydrolysate	Knitted	Covering scales of wool with silver nanoparticle-containing keratin hydrolysate crosslinked with transglutaminase	8.0 (keratin)	Batch	Woolmark TM 31	7.12	1. AOX-free treatment. 2. Increases the strength of the fabric	1. Costly treatment 2. May affect the handle 3. May not show the long-term durability of the chlorine-Hercosett process.	[90]

**Table 4**  
 Combined treatments based on the removal of 18-MEA and descaling of wool fiber followed by coating with a polymeric resin for the shrink-resistance of wool fiber.

Treatment	Form of substrate	Mode of action	Oxidant or enzyme dosage	pH	Temp. (°C)	Time (min)	Resin conc. (g/l)	Treatment method	Test method	Shrinkage (%)	Merits	Demerits	Ref.
UV/sericin	Fabric	Two-step UV oxidation followed by treatment with sericin	172 nm excimer lamp	n/a	n/a	5	5	Batch	Woolmark TM 31	0	1. Chlorine-free oxidation treatment doesn't produce any effluent.	1. Highly expensive 2. Not effective and may affect handle	[19]
Plasma and fluorocarbon	Yarn	Two-step soaking in a fluorocarbon-modified acrylic acid monomer and then plasma treatment was carried out	65 W	n/a	n/a	n/a	1.25–5.00% (w/v)	Continuous	Soaked in 1% sodium acetate at 75 °C and then tumble-dried.	9.0–12.0	1. Not an AOX-free treatment 2. Expensive process	1. Poor shrink-resistance 2. May affect the dyeability of wool	[91]
Plasma and fluorocarbon polymer	Fabric	Single-stage plasma treatment of wool with tetrafluoroethylene	100 W 13.56 MHz RF Plasma	n/a	n/a	1–30	n/a	Batch	Woolmark TM 185	12.0–2.7	1. chlorine-free treatment 2. Excellent shrink-resistance	1. Slow and expensive treatment 2. The treatment may affect the dyeability of wool	[92]
Plasma and fluorocarbon polymer	Fabric	Single-stage plasma treatment of wool with hexafluoropro-pylene	100 W 13.56 MHz RF Plasma	n/a	n/a	1–30	n/a	Batch	Woolmark TM 185	35.6–8.1	1. Chlorine-free treatment with excellent shrink-resistance	1. Poor shrink-resistance	[92]
Protease/chitosan	Fabric	Coating of wool with chitosan after the enzymatic treatment with Savinase	2.00%	5.5	50	30	10	Batch	Woolmark TM 31	3.1	1. AOX-free treatment 2. Quite effective	1. Slow treatment 2. May not be durable to wash	[94]
Protease/fluorocarbon	Fabric	Coating of wool with Nuva HPU after the enzymatic treatment with Savinase	2.00%	5.5	50	30	60	Batch	Woolmark TM 31	2.5	1. AOX-free treatment 2. Quite effective	1. The treatment is slow 2. May affect the dyeability of the treated fiber	[95]
Glow discharge plasma/ Basolan MW	Fabric	Two-step plasma treatment followed by coating with chitosan	30 W/2% owf	n/a	n/a	5	2% owf	Batch	IWS TM 31	2.0–3.5	1. Chlorine-free treatment 2. Very good shrink-resistance	1. The silicone coating may not be durable in the long run	[96]
Plasma/amino-functional poly(dimethyl-siloxane)	Fabric	Two-stage plasma treatment followed by pad-dry-bake treatment with a siloxane polymer		n/a	n/a	1–3 s	5.0% owf	Batch			1. Chlorine-free treatment with moderate shrink-resistance	2. Long-term durability of the silicone coating is questionable.	[97]
Plasma/amino-functional silicone polymer	Fabric	Two-stage plasma treatment followed by treatment with a silicone polymer	50, 100, 150 W 13.56 MHz RF Plasma	n/a	n/a	60 s	2.0	Batch	AATCC TM 99	3.2, 2.8, 2.0	1. Chlorine-free treatment with excellent shrink-resistance	2. Long term durability of the silicone coating is questionable.	[98]
H <sub>2</sub> O <sub>2</sub> /Hercosett	Knit fabric	H <sub>2</sub> O <sub>2</sub> /Hercosett micellar system	2.7 g/10 g wool	n/a	n/a	15	0.125 g/10 g wool	Batch	Super-wash test	>10.0	AOX-free	1. May not be durable to washing	[99]



Plasma/protease/chitosan	Fabric	Three-step plasma/protease treatment followed by coating with chitosan	15 passes at 0.45 m/min and 2 g/l chitosan	8	70	60	n/a	Batch	Woolmark TM 31	5.0	1. Reasonable shrink-resistance 2. AOX-free	1. Quite expensive and slow process [100]
Plasma/chitosan	Fabric	Two-stage plasma treatment followed by the treatment with chitosan	50, 100, 150 W	n/a	n/a	60 s	0.3% owf	Batch	AATCC TM 99	1.4, 1.9, 1.6	1. AOX-free treatment 2. Quite effective	1. Expensive treatment [102]
H <sub>2</sub> O <sub>2</sub> and chitosan	Fabric	Two-step alkaline hydrogen peroxide treatment followed by treatment with chitosan	18 ml/l H <sub>2</sub> O <sub>2</sub> (30%) liquor ratio	9	60	120	3	Batch	Woolmark TM 31	1.0 after 1 × 5 A and 9.0 after 3 × 5 A washes	1. Chlorine-free treatment 2. Cheap process	1. Poor durability of the treatment to washing 2. May affect the handle of the treated fabric [103]
DC magnetron sputter coating with copper	Fabric	The fabric was treated with 5.0% owf and then sputtered by DC magnetron sputtering	2000 V	n/a	n/a	1, 3, 7	5.0% owf copper	Batch	AATCC TM 99	0, 0, 0	1. AOX-free treatment 2. Quite effective	1. Expensive treatment 2. May affect the dyeability of the treated fiber [107]

fabric increased to 9% just after three washes [103]. When chitosan of various molecular weights was applied on H<sub>2</sub>O<sub>2</sub> and also PMS treated wool, it was observed that both the molecular weight of chitosan and also the type of oxidative treatment influence the shrink-resistance of wool [21]. It was reported that the alkaline peroxide treatment increased the shrink-resistance of chitosan-coated wool but negatively affected the dyeability [104]. Protease treatment alone reduced the felting shrinkage of wool. However, its addition to the alkaline peroxide treatment bath improved the hydrophilicity of wool and the adhesion between the fiber and chitosan in the subsequent chitosan coating resulting in increasing the shrink-resistance of wool [105]. Chitosan applied on low-temperature microwave plasma-treated wool showed quite good shrink-resistance but the shrink-resistance increased to 8.00% only after 2 × 5 A washes [106]. The durability of this kind of treatment is questionable and also may affect the handle properties of the treated fabric but the developed treatment is eco-friendly. Borghei et al. investigated DC magnetron sputter coating of wool with copper and found that 1 min treatment was enough to make wool shrink-resist [107].

#### Shrink-resist performance

Table 4 shows the shrink-resist performance of wool fibers treated by various combination treatments based on partial or full removal of cuticles and 18-MEA followed by covering the fiber surfaces with a polymeric resin. Atmospheric plasma in conjunction with a polymeric coating is the most investigated shrink-resist treatment recently as the treated fabric shows excellent shrink-resistance. Plasma treatments in conjunction with Hercosett resin could be a viable alternative to chlorine-Hercosett treatment. Another option could be the single stage plasma treatments forming cationic hydrophilic coatings instead of hydrophobic coatings as this type of coating could be more durable compared to the two-stage plasma plus conventional pad-dry-cure based polymeric coatings and also they will not affect the dyeability of the treated fabric.

#### Merits and demerits

Other than chitosan and sericin, no other bio-based polymer has been investigated for the shrink-resistance of wool because of various reasons. Almost all of the biopolymers are hydrophilic and therefore the formed coatings will swell in water causing their breakage and removal from the fabric. The coating formed by bio-based polymers could be brittle and hard, that may severely affect the handle properties of the treated fibers and fabrics. Moreover, a lot of cross-linkers will be needed to form the coating and to reduce their hydrophilicity, which may become expensive compared to their synthetic competitors and may further affect the flexibility of the formed coating.

#### Shrink-resistance mechanisms

Depending on the treatment used, the shrink-resistance mechanism could be different. All of the oxidation treatments including enzyme treatment and corona discharge treatments damage the scales of wool fiber and therefore the felting cannot occur through the ratcheting of scales. The chlorination treatments etch the edge of scales of wool fibers [23]. The oxidation treated wool is further coated with Hercosett and silicone resins, which further smoothens the wool fiber surface. However, the fibers are not bonded together and remain as a single fiber after the treatment.

When the treated fabrics are soaked in water, the Hercosett resin swells and covers the inter-scale gaps so that interlocking

of scales between fibers does not occur and also limits the movement of fiber in yarns. Fig. 11 shows SEM images of untreated, chlorine-treated, and chlorine-Hercosett treated wool fibers. It can be seen that after the chlorination wool fiber scales are etched and descaled. After the treatment with Hercosett resin, the fiber surface is quite covered by the Hercosett resin and the resin uniformly spread on the surface of the fiber. For the wool fibers treated by the two-stage oxidation followed by the coating with a polymeric resin, during laundering, wool fibers do not interlock and therefore felting shrinkage does not occur.

On the other hand, in the case of shrink-resist treatments based-on binding the fibers by polymeric coating (such as the treatment with a polyurethane containing bisulfite adduct and Bunte-salt terminated polyether), the polymers not only form a smooth coating on the fiber surface but also binds the fibers together as shown in Fig. 12. During laundering, the fibers cannot move and therefore no shrinkage occurs. In the case of plasma treatment, the etching of scales takes place to a level where complete descaling of wool fibers may occur (Fig. 13), resulting in the production of a hydrophilic surface. It enables the formation of very smooth coatings on wool fibers in the case of coating with hydrophilic resins and biopolymers. The descal-

ing and coating of the surface of wool fibers do not allow locking of fibers during laundering and therefore no shrinkage of fabrics occurs.

#### Future trends

Modern consumers desire that the textile material they are wearing must be ethically produced without harming the environment. From the manufacturer's point of view, for any novel shrink-resist treatment to be successful to replace the widely practiced chlorine/Hercosett treatment must meet the following conditions and challenges:

- The processing cost must be similar or marginally higher than the cost of the chlorine-Hercosett treatment
- The process needs to be continuous
- The process must be robust and should provide long-term durability to washing
- The treatment must not negatively affect the dyeability, light fastness, yellowness, abrasion resistance, stain-resistance, wash fastness and handle properties of the treated fabric
- Must be eco-friendly and energy efficient

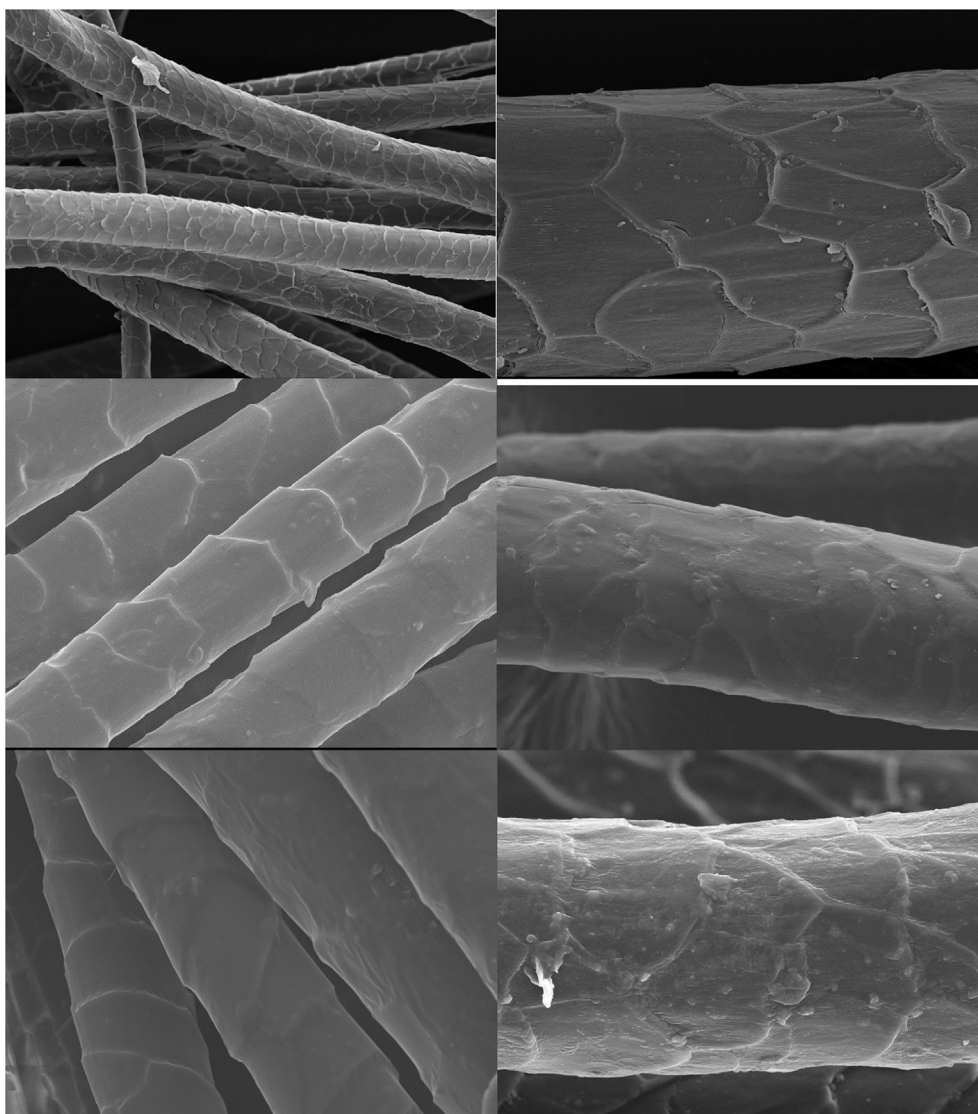
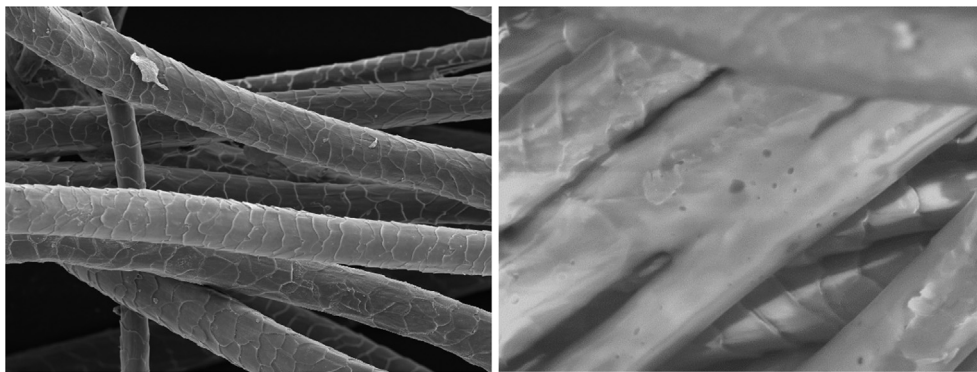
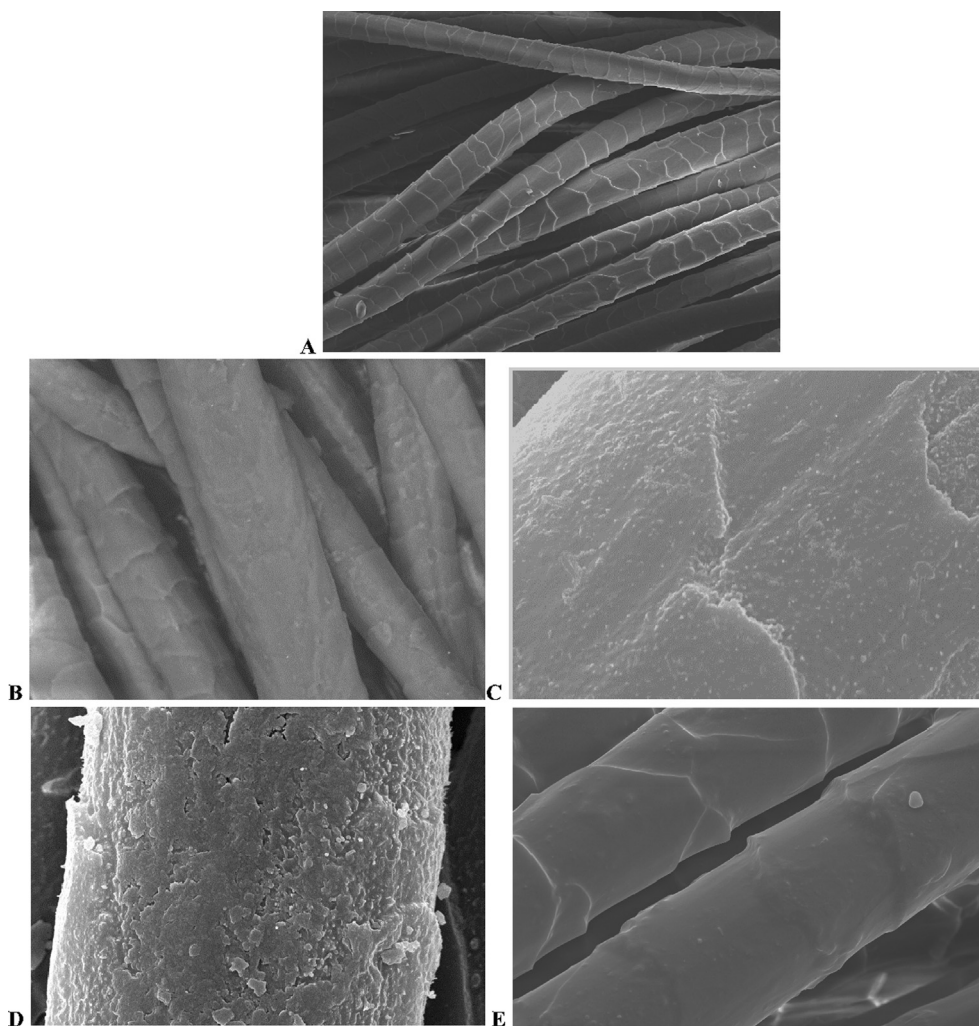

Fig. 11. SEM micrographs of untreated (top), chlorinated (middle) and chlorine-Hercosett treated (bottom) wool fibers.



**Fig. 12.** SEM micrographs of untreated (left) and Bunte-salt terminated polyether treated (right) wool fibers.



**Fig. 13.** SEM micrographs of untreated (A), DC magnetron sputter plasma using argon (B), 140-watt oxygen plasma (C), 1% oxygen plasma at 2 mm plasma jet distance (D) and low-temperature argon plasma treated wool coated with chitosan (E) [108].

Almost all of the traditional shrink-resist treatments used for wool fibers produce effluent that needs to be treated before discharging to watercourses. Therefore, the current trend is developing a shrink-resist process that is green, sustainable, and environmentally friendly. Ozonation-based shrink-resist treatment may fall under this category as it does not produce any toxic effluent but the Hercosett treatment produces AOX containing effluent. The durability of the shrink-resist treatment based on polymeric coating only could be an issue as the durability is very much

dependent on the durability of the polymeric coating unless there is bonding between the fiber and the polymer, and also the produced polymeric coating has enough strength to withstand abrasion. These treatments also affect the handle properties of the final finished products and also cause yellowness. Top treatment could be the preferred treatment compared to yarn/fabric stage treatment as individual fibers are coated in the case of top treatment. However, the continuous plasma-based treatments using polymerizing gas could be the future shrink-resist method as the

produced coatings on the fibers are ultrathin (few nanometers) and very robust that hardly can affect the natural feeling and handle properties of the wool fiber. The cost of production is high because of high initial investment cost and high-energy cost. However, the cost will go down with a decreasing energy cost and certainly, they are the future for the shrink-resistance of wool fibers. Therefore it can be concluded that the future shrink-resist treatments used for wool will be certainly more eco-friendly and sustainable than the existing methods used.

## Conclusions and future perspectives

A wide range of treatments including oxidative, enzymatic and plasma have been investigated to make wool fiber shrink-resist. However, still, the chlorine-Hercosett treatment is one of the most effective, durable and the cheapest shrink-resist treatment developed for wool. However, the treatment is under scrutiny because of the negative environmental effect imposed by its effluent. Enzymatic treatment is not the answer as the treatment is very slow, unpredictable and the shrink-resistance achieved is not comparable to the shrink-resistance provided by the chlorine-Hercosett process. The cost of generation of ozone is high and they corrode metals and most of the plastics but ozone-based treatment does not produce harmful effluent. Non-polymerizing gas-based continuous plasma treatments are effective, highly durable but the cost of production is high and also damages the fiber. Polymerizing-gas based continuous plasma treatment alone or plasma in a combination with biodegradable polymeric coating-based treatments will need to be developed for the shrink-resistance of wool. They could be the future green and sustainable shrink-resist treatment for wool and other animal fibers.

## Conflict of interest

*The authors have declared no conflict of interest.*

## Compliance with Ethics Requirements

*This article does not contain any studies with human or animal subjects.*

## References

- [1] Unravelling the Structure of the Wool Fiber and Other Keratins, CSIRO, Australia, 2011. Available from: URL: <https://csiropedia.csiro.au/wool-fibre-structure/>.
- [2] Hassan MM, Leighs SJ. Quick-dryability of various quick-drying polyester and wool fabrics assessed by a novel method. *Drying Technol* 2017;35:585–92.
- [3] Marshall RC, Orwin DF, Gillespie JM. Surface structure and biochemistry of mammalian hard keratin. *Electron Microsc Rev* 1991;4:47–83.
- [4] Whewell CS, Rigelhaupt L, Selim A. Mechanism of milling shrinkage of wool fabrics. *Nature* 1944;154: 772–772.
- [5] Mori M, Matsudaira M. Comparison of woolen eco-friendly anti-felting treatment with classic anti-felting procedures. *Text Res J* 2013;83:208–15.
- [6] Chowdhury AKR. Principles of textile finishing. Duxford (Cambridge): Woodhead Publishing; 2017.
- [7] Asquith RS, Gardner KL, McGarel WS, Otterburn MS. Hercosett-57 resin deposition on wool and modified wools. *J Appl Polym Sci* 1978;22:3267–75.
- [8] Cardamone JM, Yao J, Nuñez A. DCCA shrinkproofing of wool. Part I: Importance of antichlorination. *Text Res J* 2004;74:555–60.
- [9] Cardamone JM, Yao J, Nuñez A. DCCA shrinkproofing of wool. Part II: Improving whiteness and surface properties. *Text Res J* 2004;74:565–70.
- [10] Jovančić P, Jocić D, Trajković R, Drobnjak S. Optimization of the use of Basolan DC in the shrink-resist treatment of wool. *J Text Inst* 1993;84:49–56.
- [11] van Rensburg NJJ, Veldsman DP. On the continuous shrinkproofing of wool top by the Basolan DC process. SAWTRI Tech Report No. 32, 1964.
- [12] Denning RJ, Freeland GN, Guise GB, Hudson AH. Reaction of wool with permonosulfate and related oxidants. *Text Res J* 1994;64:413–22.
- [13] Lenting HBM, Broekman H, Guebitz GM, Kokol V, Shen J. Industrial production of enzyme-modified wool fibers for machine-washable bed coverings. *Biotechnol J* 2009;4:1441–9.
- [14] Kaur A, Chakraborty JN. Controlled eco-friendly shrink-resist finishing of wool using bromelain. *J Clean Prod* 2015;108:503–13.
- [15] Cardamone JM, Nuñez A, Ashby R, Dudley R. Activated peroxide for enzymatic control of wool shrinkage. Part I: Elucidation. *Text Res J* 2006;76:99–108.
- [16] Zheng Q-S, Li L, Jia GQ, Wang W. Study of shrink proofing on cashmere fibers treating with  $KMnO_4$ -papain. *Wool Text J* 2012;40:33–7.
- [17] El-Sayed H, Kantouch A, Heine E, Höcker H. Developing a zero-AOX shrink-resist process for wool. Part 1: Preliminary results. *Col Technol* 2001;117:234–8.
- [18] Wang P, Wang Q, Fan X, Cui L, Yuan J, Chen S, et al. Effects of cutinase on the enzymatic shrink-resist finishing of wool fabrics. *Enzyme Microb Technol* 2009;44:302–8.
- [19] Gupta D, Natarajan S. Cleaner process for shrink-proofing of wool using ultraviolet radiation and sericin. *J Text Inst* 2016;108:147–53.
- [20] Juliá MR, Pascual E, Erra P. Influence of the molecular mass of chitosan on shrink-resistance and dyeing properties of chitosan-treated wool. *Coloration Technol* 2000;116:62–7.
- [21] Parry DAD, Steinert PM. Intermediate filament structure. Heidelberg, Germany: Springer-Verlag; 1995.
- [22] Leeder JD. The cell-membrane complex and its influence on the properties of the wool fiber. *Wool Sci Rev* 1986;63:3–35.
- [23] Binnig G, Quate CF, Gerber C. Atomic force microscope. *Phys Rev Lett* 1986;56:930–3.
- [24] Crick FHC. The packing of  $\alpha$ -helices: simple coiled-coils. *Acta Crystallogr* 1953;6:689–97.
- [25] Crewther WG, Dobb MG, Dowling LM, Harrap BS. Structure and aggregation of low-sulphur proteins derived from alpha keratins. In: Symposium on Fibrous Proteins Australia 1967, Crewther WG, editor. Sydney, Butterworths (Australia), 1968, p. 329–40.
- [26] Ahmadi B, Speakman PT. Suberimidate crosslinking shows that a rod-shaped, low cystine, high helix protein prepared by limited proteolysis of reduced wool has four protein chains. *FEBS Lett* 1978;94:365–7.
- [27] De Fries W, Altenhofen U, Zahn H. A protein chemical investigation of the chlorine-Hercosett process. *Coloration Technol* 1983;99:13–6.
- [28] Guise CB, Smith GC. The chemistry of a polyamide-epichlorohydrin resin (Hercosett 125) used to shrink-resist wool. *J Appl Polym Sci* 1985;30:4099–111.
- [29] Levene R, Cohen Y. An oxidative batch-wise shrink-resist treatment for wool using monoperoxy-phthalic acid. *Coloration Technol* 1996;112:44–9.
- [30] CTC-EURODYE shrink-resist treatment for wool, Technical brochure, CTC-EURODYE Limited, Belgium, 1998.
- [31] Lewis DM, Hawkes JA. Relating to wool treatment. United States Patent Application 20150252521 A1, 9 October, 2015.
- [32] Summerfelt ST. Ozonation and UV irradiation—An introduction and examples of current applications. *Aquacult Eng* 2003;28:21–36.
- [33] Hassan MM, Hawkyard CJ. Decolorization of spent dyebath with ozone and re-use of spent dyebath. In: Christie RM, editor. Environmental Aspects of Textile Dyeing. Cambridge: Woodhead Publishing Limited; 2007. p. 149–90.
- [34] Karakawa T, Umehara R, Ichimura H, Nakase K, Ohshima K. Continuous shrink-resist process of wool top sliver with ozone. I. Performance. *Sen'i Gakkaishi* 2002;58:135–42.
- [35] Ning F, Wang J, Yu W. Effects of ozone treatment on wool scales and mechanical properties. *Appl Mech Mater* 2012;152–154:852–5.
- [36] Kobayashi T, Arisawa M, Ngoc NL, Trang TC, Myoubudani H. Surface modification of polymer textiles by thermally dried ozone. *J Adhesion Sci Technol* 2011;25:1849–59.
- [37] Choinsard L, Bigan M, Blondeau D, Dhulster P, Leman B, Guillochon D. Application of the method of the experimental design to the study of a processing of unshrinkableness of wool fibers. *J Appl Polym Sci* 2003;89:535–47.
- [38] Lewis DM. The preparation of Bunte salt-terminated surface-active agents and their use in wool fabric shrinkproofing. *Coloration Technol* 1999;115:59–61.
- [39] Hassan MM. Wool fabrics coated with an anionic Bunte salt-terminated polyether: Physicomechanical properties, stain resistance, and dyeability. *ACS Omega* 2018;3:17656–67.
- [40] Hassan MM, Leighs SJ. Effect of surface treatments on physicomechanical, stain-resist, and UV protection properties of wool fabrics. *Appl Surf Sci* 2017;419:348–56.
- [41] Dychdala GR. Chlorine and chlorine compounds. In: Black SS, editor. Disinfection, sterilization and preservation. Philadelphia (PA): Lea and Febiger; 1977. p. 167–95.
- [42] Amy G, Bull R, Craun GF, Pegram RA, Siddiqui M. Disinfectants and disinfectant by-products. environmental health criteria 216, Geneva: World Health Organization; 2000.
- [43] Obendorf SK, Varanasi A, Mejlal R, Thellersen M. Function of lipase in lipid soil removal as studied using fabrics with different chemical accessibility. *J Surf Deterg* 2001;4:233–45.
- [44] Yoshida S, Hiraga K, Takehana T, Taniguchi I, Yamaji H, Maeda Y, et al. A bacterium that degrades and assimilates poly(ethylene terephthalate). *Science* 2016;351:1196–9.
- [45] Silva CJSM, Zhang Q, Shen J, Cavaco-Paolo A. Immobilization of proteases with a water-soluble-insoluble reversible polymer for treatment of wool. *Enzyme Microb Technol* 2006;39:634–40.
- [46] Smith E, Zhang Q, Shen J, Schroeder M, Silva C. Modification of Esperase® by covalent bonding to Eudragit® polymers L 100 and S 100 for wool fiber surface treatment. *Biocatal Biotransform* 2008;26:391–8.

- [47] Silva CJS, Prabakaran M, Gübitz G, Cavaco-Paolo A. Treatment of wool fibers with subtilisin and subtilisin-PEG. *Enzyme Microbiol Technol* 2005;36:917–22.
- [48] Hassan MM. Antimicrobial coatings for textiles. In: Tiwari A, editor. *Handbook of Antimicrobial Coatings*. Amsterdam, Netherlands: Elsevier; 2018. p. 321–56.
- [49] Novák I, Valentin M, Špitálský Z, Popelka A, Sestak J, Krupa I. Superhydrophobic polyester/cotton fabrics modified by barrier discharge plasma and organosilanes. *Polym-Plast Technol Eng* 2018;57:441–8.
- [50] Zanini S, Freti S, Citterio A, Riccardi C. Characterization of hydro- and oleo-repellent pure cashmere and wool/nylon textiles obtained by atmospheric pressure plasma pre-treatment and coating with a fluorocarbon resin. *Surf Coat Technol* 2016;292:155–60.
- [51] Hassan MM. Enhanced antistatic and mechanical properties of corona plasma-treated wool fabrics treated with 2,3-epoxypropyltrimethylammonium chloride. *Ind Eng Chem Res* 2014;53:10954–64.
- [52] Thorsen WJ, Landwehr RCA. Corona-discharge method of producing shrink-resist wool and mohair. *Text Res J* 1970;40:688–95.
- [53] Höcker H. Plasma treatment of textile fibers. *Pure Appl Chem* 2002;74:423–7.
- [54] Ceria A, Rombaldoni F, Rovero G, Mazzuchetti G, Sicardi S. The effect of an innovative atmospheric plasma jet treatment on physical and mechanical properties of wool fabrics. *J Mater Process Technol* 2010;210:720–6.
- [55] Bogaerts A, Neyts E, Gijbels R, van der Mullen J. Gas discharge plasmas and their applications. *Spectrochim Acta B* 2002;57:609–58.
- [56] Mori M, von Arnem V, Dinkelmann A, Matsudaira M, Wakida T. Modification of wool fibers by atmospheric plasma treatment. *J Text Inst* 2011;102:534–9.
- [57] Liu T-T, Li Y-Q, Liu J-Q, Deng L-M. Application situation of wool shrink-proofing treated with plasma and multi-plasma processing. *Wool Text J* 2011;39:56–8.
- [58] Janca J, Czernichowski A. Wool treatment in the gas flow from gliding discharge plasma at atmospheric pressure. *Surf Coat Technol* 1998;98:1112–5.
- [59] Hesse A, Thomas H, Höcker H. Zero-AOX shrinkproofing treatment for wool top and fabric. Part I. Glow discharge treatment. *Text Res J* 1995;65:355–61.
- [60] Dai XJ, Elms FM, George GA. Mechanism for the plasma oxidation of wool fiber surfaces from XPS studies of self-assembled monolayers. *J Appl Polym Sci* 2001;80:1461–9.
- [61] Carr CM, Dodd KJ, Connors MA, Henderson A, Vickerman J. The effect of corona treatments on the hygral expansion of wool worsted fabrics. *Coloration Technol* 1994;110:383–6.
- [62] Tokino S, Wakida T, Uchiyama H, Lee M. Laundering shrinkage of wool fabric treated with low-temperature plasmas under atmospheric pressure. *Coloration Technol* 1993;109:334–5.
- [63] Cardamone JM, Yao J, Nuñez A. Controlling shrinkage in wool fabrics: effective hydrogen peroxide systems. *Text Res J* 2004;74:887–98.
- [64] Cardamone J. Activated peroxide for enzymatic control of wool shrinkage. Part II: Wool and other fiber-type fabrics. *Text Res J* 2006;76:109–15.
- [65] Wakida T, Lee M, Jeon JH, Tokuyama T, Kuriyama H, Ishida S. Ozone-gas treatment of wool and silk fabrics. *Sen'i Gakkaishi* 2004;60:213–9.
- [66] Jovančić P, Jocić D, Molina R, Juliá MR, Erra P. The combined low-temperature plasma/enzyme wool shrink-resist treatment. *AATCC Rev* 2003;3:25–8.
- [67] Millington K. Comparison of the effects of gamma and ultraviolet radiation on wool keratin. *Col Technol* 2000;116:266–72.
- [68] Guise GB. Polybutadiene shrink-resist and durable-press finishes for wool. *Text Res J* 1977;47:163–71.
- [69] Stapleton IW. Shrink-resist efficiency enhancement of two polymers on wool by polyamine pretreatments. *Text Res J* 1978;48:705–9.
- [70] Cook JR, Fleischfresser BE. Shrink resisting wool with Synthappret BAP: The effect of drying conditions. *Text Res J* 1985;55:607–14.
- [71] Lewis DM. Applying shrink resist polymers to wool fabrics at room temperature using pad-store methods. *Text Res J* 1982;52:580–6.
- [72] Brown TD, Rushforth M, Shaw T, Dobinson B, Massy DJR, Wilson W, et al. Shrinkproofing wool by means of polythiols. *Text Res J* 1976;46:170–84.
- [73] Whitfield RE, Miller LA, Wasley WL. Wool fabric stabilization by interfacial polymerization. Part I: Polyamides. *Text Res J* 1961;31:704–12.
- [74] Guise GB, Jones FW. Shrink-resisting wool with poly(dimethylsiloxane)-alpha, omega-diols and amino-functional silane crosslinking agents. Part II: Influence of crosslinking agent structure. *Text Res J* 1983;53:445–52.
- [75] Yu D, Cai JY, Church JS, Wang L. Click chemistry modification of natural keratin fibers for sustained shrink-resist performance. *Int J Biologic Macromol* 2015;78:32–8.
- [76] Domínguez JG, Erra P, De La Maza A, Juliá MR, Barella A, Shaw T. The application of the Hercosett-anionic-surfactant process to impart shrink-resistance to wool. *J Text Inst* 1980;71:165–8.
- [77] Umehara R, Shibata Y, Ito H, Sakamoto M, Miyamoto T. Shrink-resist treatments for wool using multifunctional epoxides. *Text Res J* 1991;61:89–93.
- [78] Pardo CE, Foster RE. Wool stabilization by aqueous exhaust systems based on reactive aliphatic diisocyanates. *Text Res J* 1980;50:152–61.
- [79] <http://www.woolnews.net/news/life-fibre-ef-new-chlorine-free-hydrophobic-treatment/> [accessed on 7/2/2018].
- [80] Dodd KJ, Carr CM. Ultraviolet radiation cured coatings for shrink resist wool fabrics. *J Ind Text* 1994;23:328–35.
- [81] Hesse A, Thomas H, Höcker H. Zero-AOX shrinkproofing treatment for wool top and fabric: Part II: Collagen resin application. *Text Res J* 1995;65:371–8.
- [82] Zhang QF, Yang WF, Qiao YL, Shen XX. Application of chitosan on anti-shrinkage of wool fabric. *Adv Mater Res* 2011;331:283–6.
- [83] Smith E, Shen J. Surface modification of wool with protease extracted polypeptides. *J Biotechnol* 2011;156:134–40.
- [84] Shih C-Y, Huang K-S. Synthesis of a polyurethane-chitosan blended polymer and a compound process for shrink-proof and antimicrobial woolen fabrics. *J Appl Polym Sci* 2003;88:2356–63.
- [85] Hsieh S-H, Huang ZK, Huang ZZ, Tseng ZS. Antimicrobial and physical properties of woolen fabrics cured with citric acid and chitosan. *J Appl Polym Sci* 2004;94:1999–2007.
- [86] Hsieh S-H, Zhang F-R, Li H-S. Anti-ultraviolet and physical properties of woolen fabrics cured with citric acid and TiO<sub>2</sub>/chitosan. *J Appl Polym Sci* 2006;100:4311–9.
- [87] Zargarkazemi A, Sadeghi-Kiakhani M, Arami M, Hajir Bahrami S. Modification of wool fabric using prepared chitosan-cyanuric chloride hybrid. *J Text Inst* 2015;106:80–9.
- [88] Yang H-C, Wang W-H, Huang K-S, Hon M-H. Preparation and application of nanochitosan to finishing treatment with anti-microbial and anti-shrinking properties. *Carbohydr Polym* 2010;79:176–9.
- [89] Eslahi N, Moshggo S, Azar SK, Dadashian F, Nejad NH. Application of extracted feather protein to improve the shrink resistance of wool fabric. *J Indus Text* 2015;44:835–48.
- [90] Cardamone JM, Martin JJ. Keratin coatings for wool. Shrinkproofing and nanoparticle delivery. *Macromol Symp* 2008;272:161–6.
- [91] Millard MM, Lee KS, Pavlath AE. Continuous low-temperature discharge treatment of wool yarn. A process for making wool yarn oil repellent and shrink resistant. *Text Res J* 1972;42:307–13.
- [92] Tahara M, Nakashima Y, Takagishi T. Shrink resistance of wool fabrics treated by plasma polymerization of perfluorocarbons. *Sen'i Gakkaishi* 1996;49:37–45.
- [93] Shen J, Smith E, Chizyuka M, Prajapati C. Development of durable shrink-resist coating of wool with sol-gel polymer processing. *Fiber Polym* 2017;18:1769–79.
- [94] Onar N, Sarişik M. Application of enzymes and chitosan biopolymer to the antifelting finishing process. *J Appl Polym Sci* 2004;93:2903–8.
- [95] Lakshmanan A, Lee JS, Jeyaraj JM, Kochadai AS. Comparison of biopolymer finishing with functional finishing on wool. *Ind J Fibre Text Res* 2015;40:447–52.
- [96] Zuchairah IM, Pailthorpe MT, David SK. Effect of glow discharge-polymer treatments on the shrinkage behavior and physical properties of wool fabric. *Text Res J* 1997;67:69–74.
- [97] Naebe M, Cookson P, Denning R, Wang X. Use of low-level plasma for enhancing the shrink resistance of wool fabric treated with a silicone polymer. *J Text Inst* 2011;102:948–56.
- [98] Kim MS, Kang TJ. Dimensional properties of low-temperature plasma and silicone treated wool fabric. *Fiber Polym* 2001;2:30–4.
- [99] De La Maza A, Parra JL, Sánchez Leal J, Comelles F. Use of micellar systems as vehicles for Hercosett and hydrogen peroxide finishing of wool fabrics. *Text Res J* 1988;58:571–4.
- [100] Demir A, Karahan HA, Özdoğan E, Öktem T, Seventekin N. The synergetic effects of alternative methods in wool finishing. *Fiber Text East Eur* 2008;16:89–94.
- [101] Rahmatinejad J, Khoddami A, Avinc O. Innovative hybrid fluorocarbon coating on UV/ozone surface modified wool substrate. *Fiber Polym* 2015;16:2416–25.
- [102] Jin SY, Hong KH, Kang TJ. Effect of low-temperature plasma and chitosan treatment on the shrink resistant property and hand of wool fabrics. *Text Sci Eng (Korea)* 2005;42:241–6.
- [103] Juliá MR, Cot M, Erra P, Jocić D, Canal JM. The use of chitosan on hydrogen peroxide pretreated wool. *Textil Chem Color* 1998;30:78–83.
- [104] Juliá MR, Pascual E. The role of chitosan in wool finishing. *J Biotechnol* 2001;89:289–96.
- [105] Jovančić P, Jocić D, Molina R, Juliá MR, Erra P. Shrinkage properties of peroxide-enzyme-biopolymer treated wool. *Text Res J* 2001;71:948–53.
- [106] Erra P, Molina R, Jocić D, Juliá MR, Cuesta A, Tascon JMD. Shrinkage properties of wool treated with low-temperature plasma and chitosan biopolymer. *Text Res J* 1999;69:811–5.
- [107] Borghei SM, Shahidi S, Ghoranneviss M, Abdolahi Z. Investigations into the anti-felting properties of sputtered wool using plasma treatment. *Plasma Sci Technol* 2013;15:37–42.
- [108] Tsoi WYI, Kan CW, Yuen CWM, Tang TB. Nanoscale plasma etching-hydrophilization of keratin fibers. In: Méndez-Vilas A, Díaz J, editors. *Microscopy: Science, Technology, Applications and Education*. Badajoz: Formatex Research Center; 2010. p. 1793–9.



**Mohammad Mahbul Hassan** received a BSc. Tech. in Textile Technology from the University of Dhaka in 1993 and a Ph.D. in textile materials from the University of Manchester in 1999 under the supervision of Christopher Hawkyard (textiles), Christopher Carr (textiles), and Paul Sharratt (chemical engineering). He served as a lecturer in polymer engineering at Yamagata University (Japan) from 2001 to 2003 and then moved to Wool Research Organization of New Zealand to carry out research in the area of electroconductive coating, sustainable dyeing, polymeric modification of fibers, and biomaterials. Since 2009, he has been working as a senior scientist at AgResearch, the largest Crown research institute in New Zealand, and also as an associate editor of RSC Advances since 2015. His current research interests are mainly in sustainable processing of textiles, multi-functionalisation of textiles by nanotechnology, performance and technical textiles, biodegradable polymers, bio-based adsorbents, and biocomposites, and. He has published more than 80 research articles, book chapters, patent specifications, and confidential reports.



**Christopher Carr** received a BSc and a PhD in Chemistry from the University of Wales, in 1980 and 1983 respectively. After few short spells at Scottish College of Textiles, US Department of Agriculture and CSIRO, he joined at the Scottish College of Textiles in 1988 as a lecturer. After which he moved to the Department of Textiles of the University Manchester as a lecturer in 1992, where he became a professor and deputy head of the School of Materials in 2004. In 2013, he moved to Leeds University to take the position of head of the School of Design and until now he is working at that University as the professor of textile technology and the head of the School of Design. He supervised numerous Ph.D. theses and is a renowned expert in the areas of chemical processing of textiles including wool fiber, easy care finishing of cotton and wool, fiber degradation and protective mechanisms, hair performance and surface chemistry, general wet chemical and biotechnological modification of textiles, filtration, recycling, and technical textiles.