

a MANUAL
for URBAN
PROJECTION

Generous support was provided by
Creative Capital and Carnegie Mellon
University

Editor: Josh Boyette
Readers: Ben Gansky, Claire Hentschker,
Ben Moren, Kaitlyn Schwalje

Designer: Matthew Rezac

Printed in Minnesota by Modern Press

This work is licensed under the Creative
Commons Attribution-NonCommercial 4.0
International License. To view a copy of
this license, visit <http://creativecommons.org/licenses/by-nc/4.0/>.



a MANUAL for URBAN PROJECTION

- 6 Welcome
- 8 Overview

PART 1
CONCEPTS

- 12 Time/Update
- 14 Places/People
- 16 Light/Image
- 18 Systems/Senses
- 20 Play/Work
- 22 Story/Experience

PART 2
TOOLS

- 26 Elements
- 44 Roles
- 46 Superpowers
- 48 Questions

PART 3
SCENARIOS

- 56 Scenarios
- 58 Drawing
- 60 Interviews
- 62 Mobile Cart
- 64 Mobile Bike
- 66 Computerless
- 68 Theater
- 70 Miniatures
- 72 Dioramas
- 74 Ghosts
- 76 Games
- 78 Collective
- 80 Statuevision
- 82 Battle of Everyouth

PART 4
RESOURCES

- 86 Readings
- 88 MUP Online
- 89 Cutouts

Welcome

Welcome to A Manual for Urban Projection (MUP), a resource guide for people projecting images in public places.

Urban Projection (UP) is the art of using video projection in urban environments for informational, tactical, or artistic purposes. A low-cost, high-visibility, environmentally-friendly, and ephemeral medium, UP can occur at many scales: from large city commissions to spontaneous performances, from weekly group outings with custom equipment to the simple act of opening an apartment window and projecting images on the opposite wall.

UP provides a special way of being together in the city, activating the desire in all of us to see things come alive. As a medium, UP provides tools and instruments for layering changing images on fixed surfaces. As a practice, UP mobilizes a series of techniques for applying these images in the public realm. As a collective language, UP brings visions and ideas to fruition through temporary rather than permanent means. Playful social scenarios allow us to collectively experience the world around us, exploring how wonder, action, and exchange help us re-invent our cities, societies, and ourselves.

UP relies on three important factors coming together: projection technologies, a place to explore, and people with a good attitude. Projection technologies are instruments for making big pictures with light that can be animated in expressive and responsive ways. Places invite collective exploration and reflection that can activate shared pasts and futures. A good attitude helps everyone work together and learn as a team. During UP projects, many unexpected things happen. A good attitude helps people encounter hurdles with creativity and transform challenges into opportunities.

A Manual for Urban Projection (MUP) is a resource guide that seeks to make UP more accessible. It provides an overview introduction to projection techniques, technologies and practices. It hopes to inspire dialogue, imagination, and collaboration for UP practitioners at all levels—from beginners to experts. Many of the scenarios MUP explores can be realized with only a computer, projector, webcam, and some free software. These scenarios can also inspire large-scale UP productions involving more complex technology and choreographed teams. MUP is for teachers, students, community organizers, union workers, social science researchers, curious citizens, urban planners, activists, immigrants, performance artists, video artists, theater companies, public arts programmers, and all kinds of people who might want to use projection in working towards a better world.

MUP is designed for easy portability, linkability, copying, and sharing. MUP in-print is designed to be carried and photocopied, and include hands-on brainstorming tool. **MUP Online** offers up-to-date examples of projects that illustrate various projection scenarios, and gear sections that help keep you connected to relevant technology developments in culture and industry.

MUP is a project of The Center for Urban Intervention Research (CUIR), which develops technologies, tools, and techniques for activating public spaces.

Overview

MUP is organized into four main parts: Concepts, Tools, Scenarios and Resources.

1. Concepts

UP is informed by concepts and ideas across disciplines—art and media history, urban planning, design, social sciences, literature and film. Six sections present some major themes that influence MUP as a theory and practice. **Time/Update** investigates avant-garde approaches to the city as a living landscape, ongoing spectacle, and open playground. **Places/People** references approaches to public social interactions through design, architecture, planning, and exchange. **Light/Image** reflects on projection history and society's ongoing engagement with drawing, cinema, and movement. **Systems/Processes** explores UP in the context of systems like global mobility, communications media technology, and urban transformation. **Play/Work** considers how art is generated through collective action, co-operation and collaboration. **Story/Experience** charts the ways that content themes, structures and narratives contribute to excellent UP projects.

2. Tools

UP productions involve networks of human and non-human **elements** that work together to activate and animate public space. Human elements include the performers, audience members, participants, and bystanders. Non-human elements include the site, projection surface, projector, light beam, computer generated video, and the signals and messages flowing around. **Roles** are starting points for effective collaboration among a group of UP participants. A series of skills, which when practiced over time, can evolve into UP **Superpowers**. **Questions** offer frameworks for considerations that arise when planning and executing an UP outing.

3. Scenarios

Scenarios provide starting points for creating an UP experience. **Diagrams** show the elements of an UP project arranged in space (projector, computer, projection beam, cameras, etc.) along with the important non-tech elements (performer, audience, trees, buildings, monuments, vistas). An **Icon Key** offers simple pictures for sketching or designing scenarios by computer or hand. The scenarios offered here are designed to encourage improvisation and public participation. Scenarios serve as inspiration for UP planning, or can be used as the ingredients in new recipes for UP compositions and performances.

4. Resources

Resources extend outlets for exploring the MUP experience in theory and practice. **Readings** references a selected list of inspirational philosophies. **MUP Online** collects relevant examples and links, and provides a platform for connecting with other UPists to share knowledge and experiences. **Cutouts** are photocopyable or printable pages for use in MUP workshops, brainstorming, and plotting.

PART

1

CONCEPTS

Time/Update

The point is to understand what has been done and all that remains to be done, not to add more ruins to the old world of spectacles and memories
—Situationist International Manifesto

Back to the Future / A new epoch is dawning on Urban Projection. Projection tools are getting better, cheaper, stronger, smaller, and smarter all the time. To make projection useful for expression, for meaning, and for social connection, we must explore its capacity to serve revolutionary ends. The night is new and ancient both. Our cities are waiting with old souls and young spirits. All is at stake.

Reclaim Capital for The 22nd Century / Capitalism is consuming everything in its path: land, natural resources, culture, society. It thinks that the world is made of money and money makes money. All is measured in profits and hoards, and enough is never enough. In its wake, capitalism leaves behind a meaningless mess: 24-hr news, big-box stores, luxury clothes, empty shopping-malls, special-interest politics, SUVs, cheap products, loud noises, oil spills, billboards, re-purposed lofts and suburban tract homes. The media stories circulated in these contexts dramatically minimize our collective experience. But time and again humans prove to be an incredibly creative species. Things genuine and valuable continue to flower in capitalism's cracks [1]. Connections and expressions between people and places are drawn up anew. We've been in love with spectacles since the very beginning [2]. UP uses spectacles to propose new stories that can remake our future.

Stand on the Shoulders of Giants / Urban Intervention (UI) extends the ideas of the Situationists, the Futurists, the Surrealists, the Dadaists, and so on, back through avant-garde generations [3]. Our predecessors opened up art to include the exceptional everyday and the everyday exception, putting art in service of the imagination, bridging art and life, moving art beyond the market, flooding the world with new desires. In solidarity, we take up this task of transforming society. We update these strategies for changing the world.

New Tools for New Forms / UP is a project of re-purposing and re-invention. UP makes tools by working with what already exists, adapting resources to new arrangements. UP uses equipment from the surveillance industry, borrows images from the information visualization community, and copies designs made for Broadway. UP learns from vehicle hobbyists and NASA researchers, and appropriates platforms from academic cartography, consumer cinematography, and social media marketing. With this trove of available resources, UP composes new platforms for people to connect, communicate, and collaborate instead of consume.

Make Something Happen / Interventions disrupt the everyday flow of things [4]. Encounters with the unexpected make people more aware of their presence with others and their influence over environments. This awareness bolsters their capacity to reinvent the world around them. They are turned on and tuned in to conditions and contexts. The typical is made strange; the given becomes contingent, concrete, malleable, distant, and intimate. Everything, finally, is urgent, significant, alive.

Places/People

People tend to sit most where there are places to sit.
—William H. Whyte

More Art Everywhere / Art in public and public art can be quite different in style and mode of address [5]. In the US, public art is commonly recognized as outdoor abstract shapes and big painted animals and light-up squiggles. Public art is typically governed by committees, controls, valuations, authorizations, and representatives, so it has to be safe in concept and character. UP often participates in public art projects, but UP is first and foremost art in public. It does not always require permission, and often prefers not request it. Authorization for art can be hard to come by, and it's often easier for authorities to grant forgiveness than approval. Whether sanctioned or pirate, UP seeks awkward and unprecedented openings where rules and regulations bend and break.

Start with Observation / UPists often start by observing how public places work and how people inhabit them. In the 1970s, urban planner and urbanist William H. Whyte studied the dynamics of active and empty urban public spaces [6]. His effort had a political purpose—private agencies were using public funds to build 'public' plazas with no public amenities. Whyte's team invented the method of 'direct observation'—using homemade time-lapse cameras and in-situ field notes to understand public places. Through a visual ethnography, Whyte discovered that what people say about spaces and how they use them is often quite different. Whyte found that people prefer spaces that provide for a diversity of basic everyday activities: sitting, eating, kissing, talking, sunning, and most importantly—people-watching. Active urban spaces work best when planning anticipates adaptability and evolution over time.

Involve the People / Observing how people move and gather helps UP repurpose social habits towards more collective ends. In that spirit, UP choreographs events with people in mind from the beginning. UP harnesses existing patterns of people moving through space—conscious histories, subconscious impulses, unconscious gestures—and incorporates these patterns into project design and content. Capitalism conditions us to pre-suppose opposing teams: allies and enemies, friends and strangers. But people are more often than not willing to go out of their way to lend a hand. UP finds generosity everywhere: in shopkeepers, kids, families, workers, homeless people, and the authorities too [7]. Bystanders become intentional participants, and as many people as possible become collaborators in the process.

Reclaim Mythical Places / Places build up a charm, draw, and gravity that stays with them over time [8]. Architectures house our myths, memories, and dreams. Broken and fallen places have extra nooks and crannies in which surplus magic resides. These places store and recover stories, organize imaginaries, and inspire conversations and anecdotes which animate the present. UP amplifies our collective connectedness to our mythical places by transforming the entire city into an outdoor theater, a mobile movie, a public page.

Light/Image

There is a crack in everything, that's how the light gets in.

— Leonard Cohen

Use Light to Tell Stories / Since the beginning of time, we've been using light to tell stories. In the beginning, the big bang lodged starlight into everything. Later, flickering torchlight and echoing voices animated drawings on the walls of the caves [9]. Eventually, practically every culture developed its own form of shadow puppetry and light theater. Then came reproduction technologies—the magic lantern, panoramas, movie pictures, rotoscope, silent films, shorts, talkies, cartoons, TV. Then *The Wizard of Oz* and technicolor, Hollywood, Disney, George Lucas, computer screens, 3-D, lasers, solar power. We are learning to channel and program light at endlessly bigger scales, activating buildings and infrastructure with formal displays and functional signs that activate their character and qualities.

Take Back the Night / UP occurs best in the nighttime, since you can't use projectors in broad daylight and our eyes and brains are especially attuned to things moving around in the dark. Illuminated and glowing, haloed and silhouetted, things take on a more supernatural, spiritual dimension. Nightlight is unexpected and impossible, daring and secretive. The night is full of danger, but also opportunity [10]. In the night light we realize our purpose, as part of something larger, in the movements of moments hard to trace and impossible to explain.

Respect Architecture / Winston Churchill once said “We shape our buildings, thereafter they shape us.” Architectures make us in its image. Through architecture we learn how to live, relate, learn, and love as strangers and friends, beings and bodies. All structures have their own logics and rules and features that keep us out and let us in. Light can augment or negate existing elements, providing transparency, clarity, indication, and safety. Projection can be a tool to help buildings speak their stories, rearranging histories and memories at their site of origin. Windows and doors, spires and spindles can become frames for moving pictures. The city becomes a stage for activating architecture with light [11].

Projection is Commentary / Projection temporarily adds images to the city, and everything added to the city is a form of commentary. Commentary is power and power is responsibility, so projection shouldn't be taken lightly. UP encourages responsibility by being thoughtful about images, locality, reference, and difference before, during and after the intervention. Content can include found footage, archival footage, new videos, close-ups, cutaways, panoramas, clear and pixelated pictures. Contexts can include social conventions, cultural values, privilege, privatization, diversity, equity, social justice and the point of art. Come to conclusions, but be ready to revise them. Things and thinking should change throughout the process [12].

Systems/Senses

sys-tem / 'sistəm/ noun

1. a set of connected things or parts forming a complex whole
2. a set of principles or procedures according to which something is done; an organized scheme or method
—Oxford Dictionary

Intro to Systems / Since UP involves lots of complex parts moving together, systems-thinking can prove a useful tool in the design of UP projects. [13]. Systems thinking considers the structures, behaviors, and interconnections of UP's inherent interactions and integrations. Take into account architecture, technology, transportation, weather, and economics. Don't forget about less visible systems such as privacy, ownership, social relations, communications, and aesthetics. Take heed of the more intimate systems—senses, perceptions, expectations, and experiences. Use maps, diagrams, charts, and lists to help visualize and conceptualize the systems at play working together. Once you're able to look at how multiple systems come together to compose an UP experience, you'll find it's easier and more fun to develop and hone your choreography.

Adaptive Systems and Processes / Since human and group natures shift and change in response to their environment, systems require regular modification, observation, and refinement [14]. Systems balance explicit and implicit parameters, controls, repetitions, paths, access points, inputs and outputs, feedback and expenditures. The interface is the contact point of humans with the system, so the best UP systems make things clear for everyone involved, no matter how complex the total project. Simple signage and information helps people approach, enter, navigate, and understand complex systems right away. Re-generative

systems make little waste, repurpose excess, and channel desires. UP systems strive to be generative, flexible, collaborative, adaptive, and friendly. People are first and foremost the most important part of any UP system.

Six Senses / Whether an interruption, a protest, an occupation, an exchange of information, or visual fantasia, UP is an aesthetic, kinaesthetic, and sensory experience [15]. Large-scale light pictures empower collective vision. Sound adds a personal or public accompaniment; mobile phones, boom-boxes, headphones, old phones, radio—multi-channel or layered, old school or new media—can be used to orchestrate audioscapes. Touch technologies should appeal to the human animal; sturdy buttons and soft, durable fabrics give people something to do with their hands. Taste and smell can catapult audiences into the hyper-real, opportunities for improvisation with the unexpected. The sixth sense is sensibility—the ways of knowing and intuition at work in our bodies. Learning and honing these sensing systems creates an ever-expanding horizon of conscious and unconscious sensitivity, wherewithal and insight.

Embrace the Unknown / Systems have a tendency towards chaos [16]. Use patience and cunning to mobilize entropy as a strength. Trust the process. Approach chaos as an opportunity, and embrace surprise. Remember that improvisation takes preparation. The more you plan and practice, the more ready you'll be to face the unexpected with creativity and imagination.

Play/Work

Aeronautics was neither an industry nor a science.
It was a miracle.
—Igo Ivan Sikorsky, aviation pioneer

Play Games, Play Time, Play Things / UP proposes a future for public play. Play replaces fear and frustration with freedom and openness. In play, imagining and inventing happen on the spot; logic and intuition, gestures and images, sense and nonsense flow together. Certain conditions make it easier for UP play to happen [17]. These conditions include familiarity and practice with technology, trust in your community, belief in your collaborators, clarity and purity of intention. Free play becomes metamorphosis and pretending—the ultimate groove.

Practice is a Practice / While UP is fun and games, it's also hard work. It's physically, cognitively, and socially demanding. It involves lots of assembling and disassembling, picking up parts and pieces, and moving things around. Pedaling, holding, typing, marking, tracing, pushing and pulling, staying, clicking, and debugging are all labors involved in UP. But over time, with patience and with practice, you get better at doing things, and doing what you're good at can be very pleasurable, and eventually this work can come to feel like a performance [18]. Repetition and variation keep you in time and make practice work and process play.

Invent New Toys and Instruments / New machines are populating the future. UP transforms machines into toys. Toys bring out the child in all of us, making people less guarded and afraid and helping people make allies and friends. The famous projectionist Krzysztof Wodiczko calls such a machine the “thing-in-between.” The thing-in-between is an object that is strange at first, unrecognizable, bringing strangers

together through curious encounters [19]. Wodiczko's instruments expose and repair our social strangeness; machines expose the otherness we carry in ourselves. Despite their reputation, strangers and robots can be very friendly. From them we learn how to come in peace.

Caring is Sharing / Collaboration happens when many people are working and playing together and everyone does their part. It's usually easier to get people to do some parts independently and some parts together than to get the whole group to do all the parts at once. To keep collaborating, individuals need to feel and give respect, and to take part in the ways that they prefer. Group cultures for coordination are easy to establish when the person setting things up communicates structures and involvement clearly, kindly, regularly, and with enthusiasm. Feedback is necessary to calibrate collaboration, and it's up to everyone to keep track of themselves and look out for others. Time should be treated with preciousness and precision. Stories, roles, and input help people contribute through desire rather than obligation [20]. Inclusion, initiative, follow-through, and creativity contributes to a happy and healthy atmosphere.

Story/Experience

Any story worth its salt can handle a little shaking up.
—Salman Rushdie, *Haroun and the Sea of Stories*

Tell the Story / Stories make us human. They bring us together, tell of struggles, connections, failures and successes. They are mythical and magical, allegorical and parabolic, logical and romantic. Stories are infinitely adaptable, changeable, and repeatable. We have new tools for telling stories, but these tools connect us to something as old if not older than ourselves. Media—radio, books, apps, theater, movies, oral histories, etc.—offer modes for unfolding stories, remembering generations, building suspense. In stories of the extraordinary and the everyday, we travel together [21]. Stories are the ultimate shared journey through time and space.

Uncover the Structure / Stories are the way that people make sense of the world, composing personal narratives from memories and experiences. For this reason, it is crucial to consider UP as a form of storytelling. All stories share a structure—a beginning, middle, and end. Stories bring out the strange time-dimensions in places. Time, like memory, does not flow evenly or linearly. Plots travel in fits and starts, prompted by interventions and inversions. Time can be expansive or contracted, fast and slow, cyclic and spiraling. Stories wake places up, inserting dreams and fictions into reality [22]. All places and people have stories living inside them that have yet to be told, and these stories can endlessly be told in a new way.

Create Intimacy / People are natural storytellers. We can start with stories that seem familiar and deepen them to discover unforeseen trajectories. Rites of passage, generational memory, chance encounters, and natural forces are common tropes. Archives and museums and monuments serve as repositories for stories; often secret artifacts and parables remain hiding amidst the official narratives. Stories of the everyday are as important as the exceptional because they expose rhythms and relations of everyday experience. Stories get suppressed to keep the systems of injustice in place, or to keep the status quo going, or to keep power structures from changing. Stories of our collective struggles bring out passion for action [23]. In the case of stories, style and affect, fiction and fantasy, are as important as truth and expression.

Collective Experiences / People happily build upon and add to one another's stories. People are characters in their own lives. They are stars and supporting cast, conductors and chorus. Adventures are stories unfolding in life and real time. Stories challenge us to discover the limits of convention, expectation, and standardization. Stories chart the possible and the impossible. Stories show us how similar and different we are all at once [24].

PART

2

TOOLS

Elements

Urban projection mobilizes a variety of complex and rapidly-changing technologies. Since specific tools and platforms are bound to be outdated before too long, **MUP Online** provides current lists and links to current developments in gear and gadgetry. The broader techniques of UP tools and platforms change less rapidly than the technologies they deploy. Mastering the non-technological parameters of UP allows UPists to use new technologies in creative and intelligent ways.

The following list of elements provides starting points for researching and evaluating UP parameters. Practitioners should develop and evolve intervention ideas with improving technologies while keeping focus on the big picture: claiming and activating public spaces with light, imagery, and conversation.

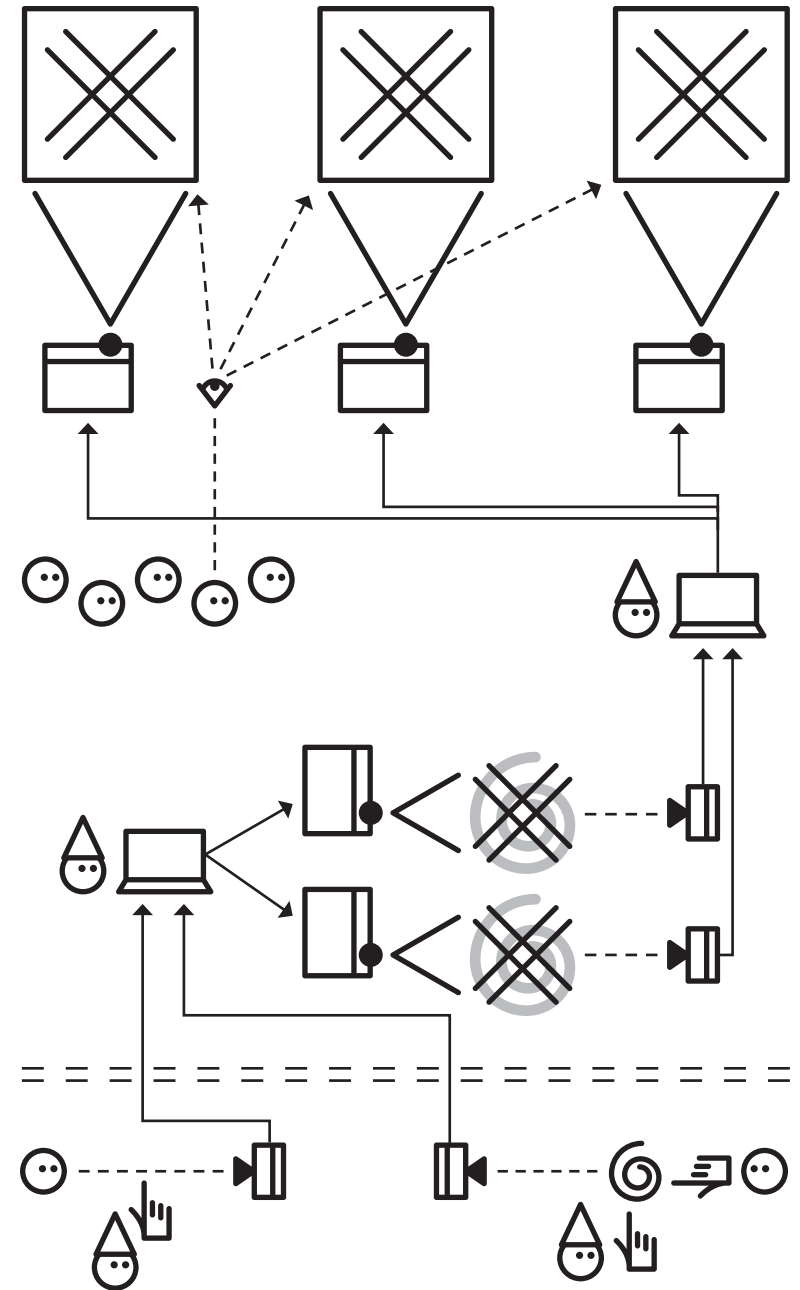

System diagram for an urban projection intervention performed by Ali Momeni and The Maw in Minneapolis in 2010. Please refer to the “Part 3: Scenarios” for a key to the graphic icons used in this diagram, as well as instructions and wisdoms on various scenarios.

Projection Surface

Any surface can be a projection screen but some surfaces work much better than others. Consider the following parameters when choosing an urban screen:

Ambient Light

Look for urban screens (buildings, trees, billboards, etc) that are dark. The darker the surface you project on, the sharper the image, the brighter the color, the bigger the size, and the further away the projector can be. The best way to block ambient light sources is with something light, inflammable, heat resistant, flexible and opaque; aluminum foil can block street lamps and floodlights; large trash cans turned upside-down can cover street lamps.

Size and Shape

Projectors project established length-to-width ratios (like 4x3, or 16x9). If your urban screen is not a rectangle of those proportions, then you'll only be projecting on a part of it, or only a part of your image will appear. Align the edges of your projections with visible architectural features of the projection surface (like doors, windows, chimneys, arches, edges, etc).

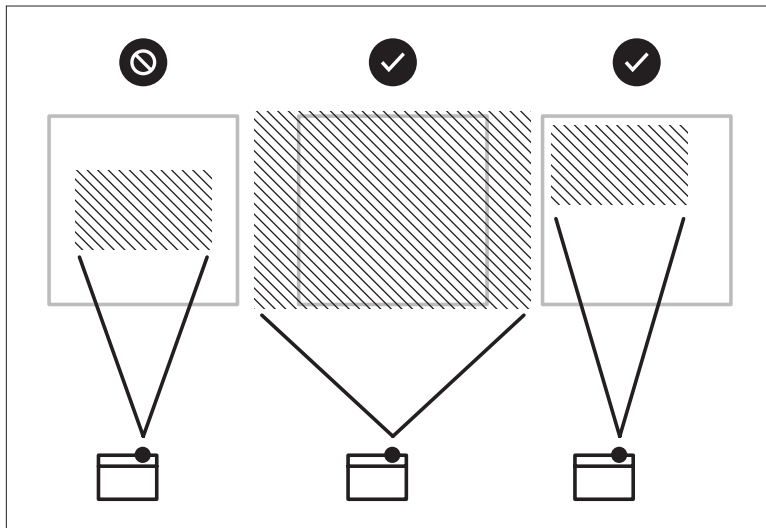

Texture

Traditional projection screens are white and smooth so that you see the image well. Any additional texture on the urban screen (i.e. patterns, ornaments, structural features, etc.) will be visible in the projected image. If your urban screen has features you cannot change, then work with them; select, arrange and align the content of your image to compliment existing features rather than compete with it.

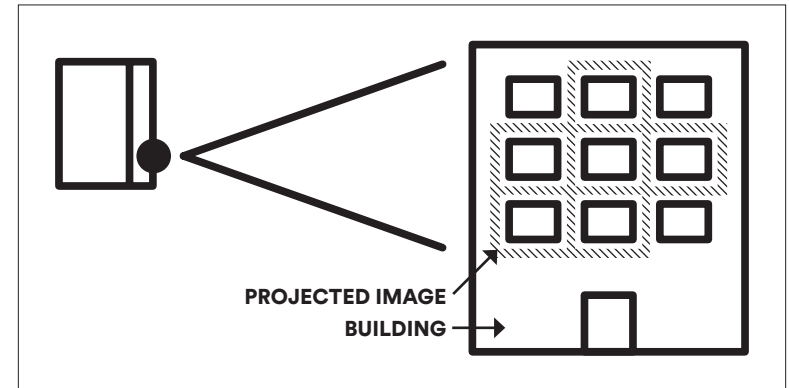

Mask

Projected images are rectangular; images in real-life are all sorts of shapes. The sharp edges of a projected image are a jarring interruption to natural and urban surroundings. Always begin with a black background and add visual elements one by one; if you're adding a rectangular photo or video, consider adding a masking that fades to black at the edges.

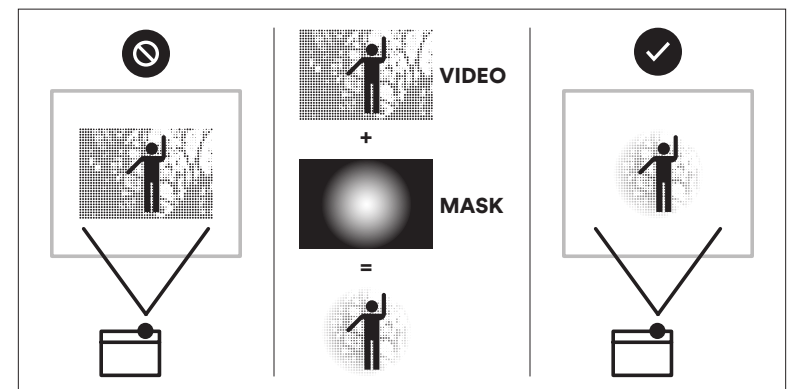

Projector

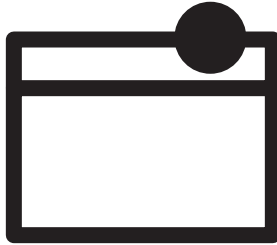

Projectors get smaller, brighter and cheaper every year. At any given time, the market has a sweet spot where the brightness to price ratio is at its best for the consumer. Refer to **MUP Online's** *Projector Picks* and consider the following metrics when selecting the projector for your project(s).

Brightness

Projector brightness is rated on a scale of lumens, but manufacturers do their own brightness testing, so user reviews are critical. There are invaluable online resources for cross comparison across models and many users' experience. As a starting guideline, 3000 lumens is the bare minimum for outdoor projection. However, remember that the color/texture of the wall and the levels of ambient light are as important as the lumen-count for getting a good image.

Electricity

Projectors are very power-hungry instruments, and batteries and generators that have enough juice are heavy. LED lighting technology helps to address this issue; some manufacturers offer projectors that use half-or-full LED lighting; this reduces the projectors' power consumption considerably, along with the heat and noise that comes with it.

Form Factor

Projectors come in many sizes and shapes. Consider the physical demands of urban projector when making your selection:

- 1 robustness:** quality of manufacturing, hardness of casing, repairability, susceptibility to accidental damage from impact, rain, dust or power surges
- 2 mountability:** universal mounts help you move around quickly and safely, and project accurately and with stability; use mounts like those employed in photography and videography applications. ¼"-20 hardware is standard in this field; look for a projector that has a female ¼"-20 threaded hole for a tripod or universal mount
- 3 weight:** urban projection can make athletic demands on the body; carrying a lot of gear, biking from place to place, climbing walls and jumping fences are all easier with lighter projectors.

Projection Beam



The light beam of the projector starts at its bulb, goes through the lens and emanates towards the projection surface. How far and in what exact direction the light shines depends on your projector. Get to know your projector's specifications and capabilities by exploring its menus and settings well before heading into the field because everything is much harder outdoors and in the dark.

Throw

As your urban screen gets further from your projector, the image gets larger and less bright. A projector's "throw ratio" indicates the distance to the screen (D) divided by the width of the projected image (W). A "throw ratio" of 2:1 means that if you're 10 feet away from the screen, the image will be 5 feet wide.

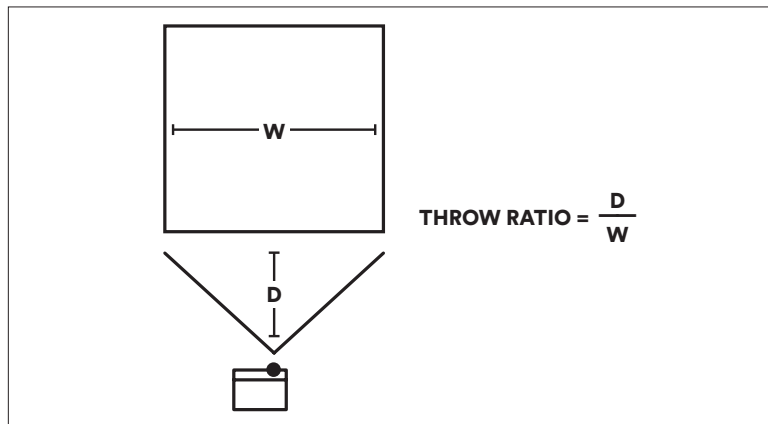

Zoom

Many projectors offer a zoom feature; the larger the zoom range of your projector, the more freedom you have in where you place the projector for the desired image size.

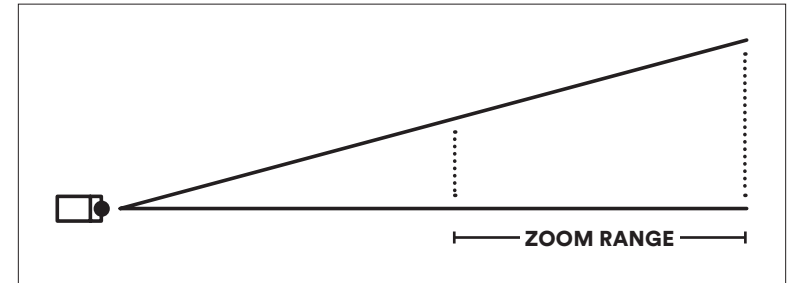

Direction

Most projectors project a rectangular image, but different projectors throw light out with slightly different angles. When the projector lens is aligned with the correct location in the projection surface, you get a perfect rectangle. If not, you get "keystoning"—an imperfect rectangle. Many projectors allow you to correct vertical keystone (if your projector is placed too high or too low). Very few projectors allow you to correct horizontal keystone (if the projector is too far to the left or too far to the right). Many software applications allow correction for keystone distortion or projection on an uneven surface.

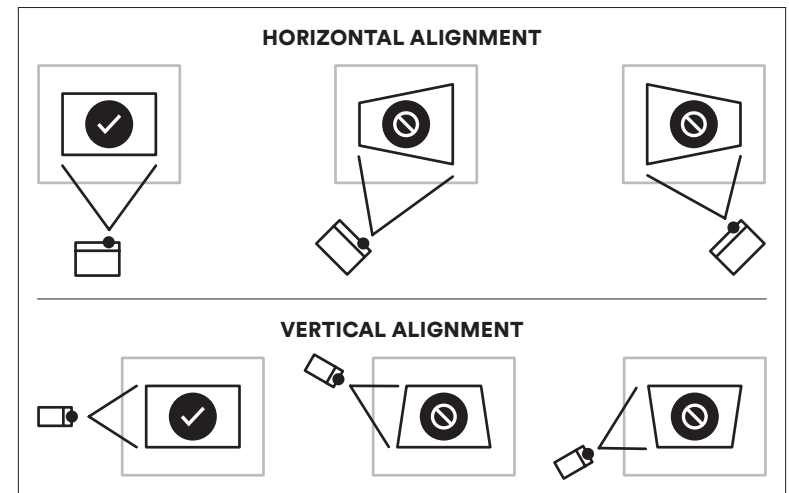

Orientation

Nearly all projectors project in landscape when mounted normally. Only a few projectors can handle being mounted sideways to project portrait and most projectors will die of overheating if they are held sideways for long stretches.

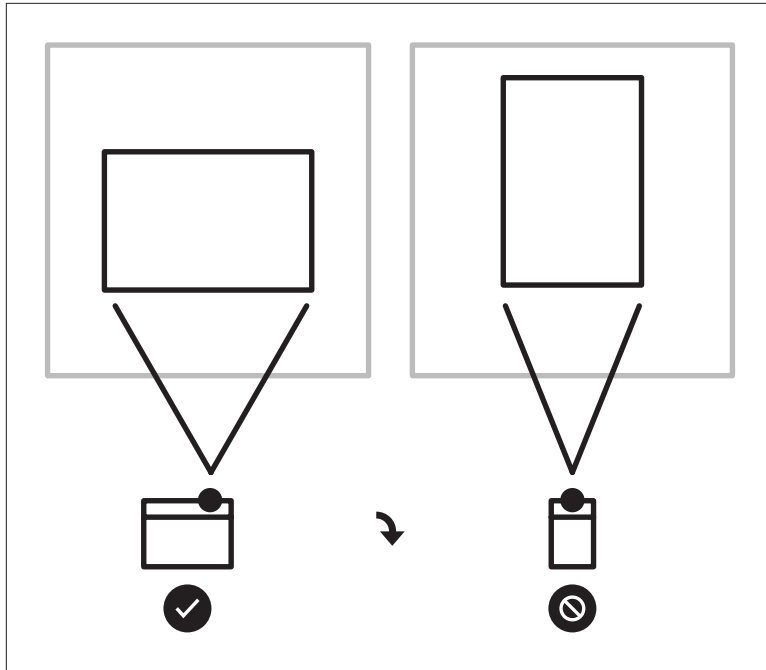

Perspective

The best view of the projected image is from directly in front of the screen. As you get further from this spot, the image becomes more distorted. In choosing an urban screen, consider the number of people that can see the projected image from a perspective that is closest to ideal.

People expect projectors to be in front of the image they project; if you want to create mystery by subverting this expectation, place the projector in an unexpected and out of sight place. Know that in doing so, you'll produce key-stoning distortion which you can correct in hardware (the projector) or software (running on a computer).

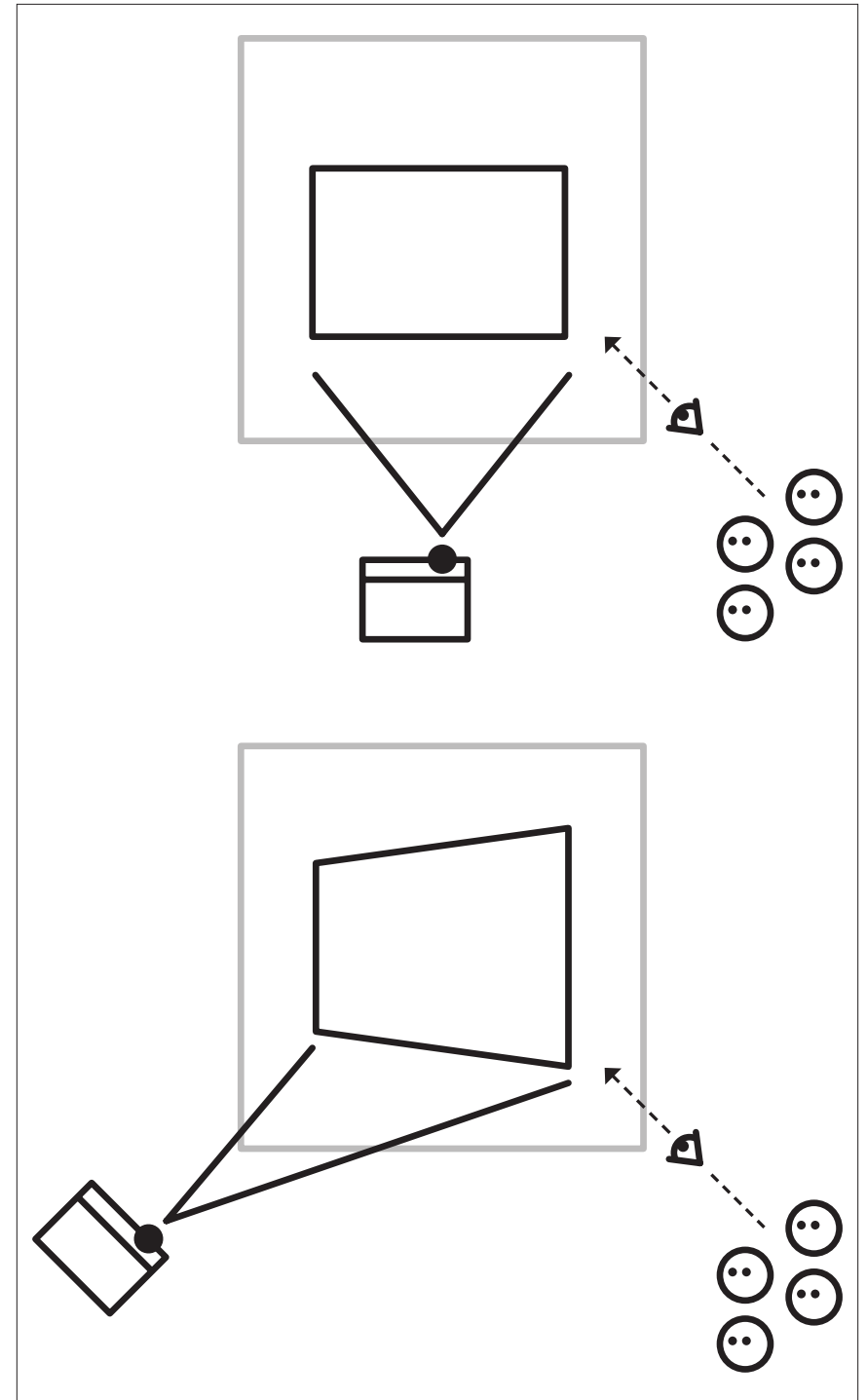

Camera

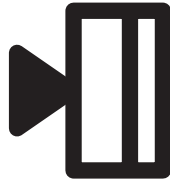

Using live video feeds from cameras in a projection intervention can create an immediate connection between the projected image and reality; this brings a lot of life to the event. Consider the following schemes for integrating a live camera feed into urban projection.

Direct

Many types of cameras can be connected to a projector. Webcams, mobile phones, industrial/scientific cameras, consumer video cameras, or DSLRs typically require a computer in order to be connected to a projector. Simpler analog cameras with composite video output—like many consumer security cameras—can be connected directly to many projectors (ones with composite input). In this case, the whole system can function without a computer. The connection between the camera and the projector can be wired, or wireless. Look into the radio control hobby community playing with driving and flying remote-control robots as they tend to be at the cutting edge of small and cheap wired and wireless cameras.

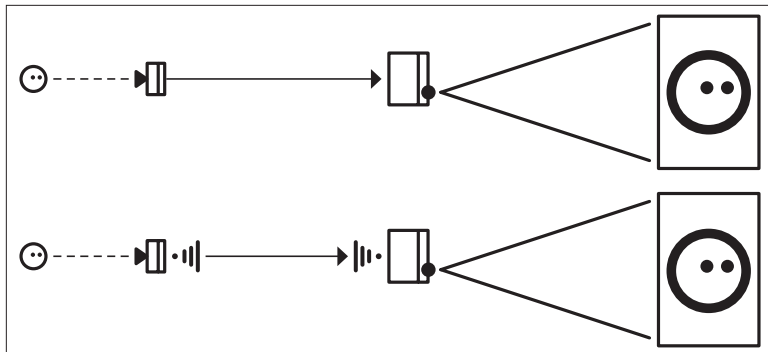

Processed

By connecting the camera to the projector through a computer, you can record, playback, scale, superimpose or apply other visual or time based effects to the video feed. These abilities introduce many new conceptual possibilities for participatory projection events, as well as functional aids like increasing the brightness/contrast of the image, or projection mapping to remove distortion.

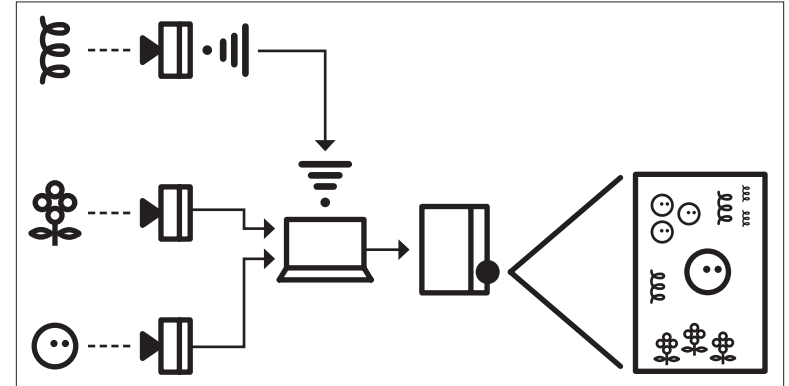

Networked

A positive aspect of the pervasive surveillance industry and modern parenting is that networked cameras (also called “IP Cameras”) are becoming very good and very cheap. Networked cameras allow you to capture and send video feeds from multiple places to the projector. They also allow you to dramatically increase the number of live camera feeds used in your urban projection.

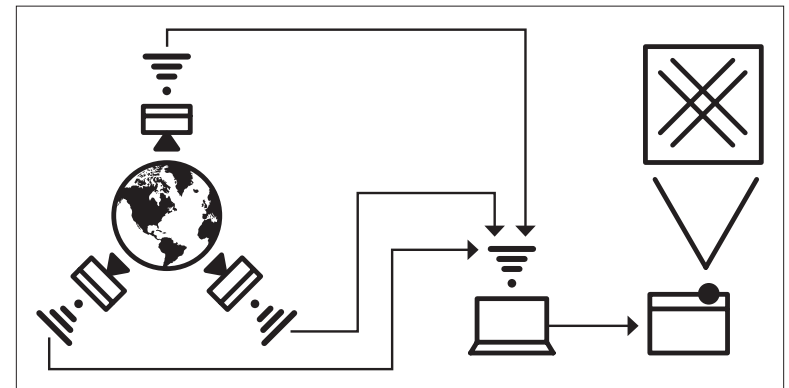

Computing

HARDWARE

Computers become faster, lighter and cheaper each year. Presently, three general platforms are relevant to urban projection:

Personal Computers

Any modern laptop that is good for video games is also good for urban projection. Even if a computer is not new and high-end, it is possible to adapt an old and familiar software application (like Microsoft Word, or Powerpoint).

Mobile Phones

Mobile phones pack a lot into very little space. They have a powerful central processing unit (CPU), good graphics, a high-resolution touch-screen, as well as cameras, sensors and network connectivity. Many of them can output video from their special connector which you connect your phone directly to a projector and not carry around a laptop.

Embedded Systems

Another fast moving field is the world of very small computers (microcontrollers and embedded systems). Hardware platforms like the Gumstix, BeagleBone, RaspberryPi, Udo, or Intel Edison are fully functioning computers: they use variants of the Linux operating system and can do video, cost less than \$100, run on batteries and take up very little space.

SOFTWARE

Accessible, free, or opensource video software has developed tremendously in the last decade. Refer to **MUP Online's Software Picks** for noteworthy options. Broadly speaking, the categories include the following:

Open Source

Open-source platforms like Processing and OpenFrameworks allow you to build a system from scratch, using programming languages that are established, well documented and taught everywhere. The communities surrounding these platforms are tight-knit, prolific, experimental and all about sharing. Many of the key players are professional educators and their involvement with developing platforms is a major part of their work. These platforms therefore have well-written Get Started guides with plenty of simple examples to learn from and complex projects to hack.

Old Standbys

A number of long-running applications like After Effects, Max, PureData, Isadora, and Quartz Composer stand out from the crowd for the sheer number of works they have enabled. These environments are powerful and complex and take years to master. Experts of these systems can be very fast at prototyping complex projection performance ideas that integrate audio-visuals and interactivity.

VJ/Broadway

A growing group of newer software packages for VJ'ing and theatrical media design are applicable to urban projection. Refer to **MUP Online's Software Picks** for a complete and evolving list.

Homebrew

Homebrew performance tools like maw.livedraw or VPT are great models for specialized tools for video projection. They are open source, extensible and contain many insights into the possibilities and amenities of video projection software.

Instrument



MUP treats UP technology as instruments. Instruments embody practice and mastery (i.e. the violin). They also fill the physical and communicative space between performer and audience member (i.e. the megaphone). A good instrument has the power to amplify the performer's intentions, be they with sound (i.e. the electric guitar) or with image (i.e. juggling balls). A good instrument has a low bar for entry—anyone can start playing—and a high ceiling for virtuosity—practice pays off exponentially (i.e. the accordion). Instruments have the ability to attract attention (i.e. the fire organ), generate fanfare (i.e. the bagpipe), bring formality (i.e. the baton), or provide comic relief (i.e. the stilt). Three constraints play a role in instrument design: the physical (how it feels to play it), the cognitive (how many things can you do at once), and the social (how does it make others feel).

Physical

Gestural control of computers can be much more intuitive, refined, legible, and fun than the mouse and keyboard. Decades of innovation in alternative controllers for musical performance have made a wide range of tools (like knobs, sliders, multi-touch, etc) cheap and available. The ergonomics of the instrument (e.g. how you're standing/seated, how you hold the instrument, how your gestures interact with it) has great impact in how well you can perform.

Cognitive

Using or playing an instrument requires paying attention to what you're doing with your body and what that's causing in turn. Projection in public space requires paying attention to everything that's going on around you. The whole experience is filled with multi-tasking. Urban projection instruments should take into account the range of expected and unexpected actions and reactions that accompany a performance in public space; these include elements like rain, wind and dust, interactions with bystanders, shop owners and authority figures, as well as incoming phone calls, SMS, and IM messages.

Social

Using a projector in public space is a form of performance and different people interpret performances differently. Instruments that look complex, delicate, and messy can appear threatening or intimidating. Instruments that are sturdy, playful and well designed can generate conversation and participation.

Signals

Power

Energy-hungry projectors make power an essential consideration in planning a projection outing. Always consider using power from the electrical grid if possible; long extension cords are lighter, safer and cheaper than generators and batteries. Generators make a lot of noise; good generators are slightly more quiet and can provide a surprising amount of power for their size (~7 hours of projection at 2500 Lumen with a Honda 2000i). Old-school Lead-Acid batteries (like the one from a car) are feasible (1–2 hours of projection at 2500 Lumen); “Gel” type Lead-Acid batteries are better as they contain no spillable toxic liquids. Large modern LiPo and LiFePO4 batteries are silent and can run projectors for many hours (~5 hours of projection at 2500 Lumen from a 60Ahr 12.8V LiFePO4) but are very costly (~\$1,000). Refer to **MUP Online’s** *Power Picks* for up to date references on mobile power solutions.

Audio Visual

Audio and video signals transmitted over cables can suffer in quality if they travel long distances or use poorly made cables. They also introduce potentially problematic opportunities for participants to trip, fall and/or interrupt the performance.

Wireless

Many signals, including audio, video, control and raw data, can be transmitted wirelessly. With the exception of power, the interconnections among most elements of UP can be wireless. The necessary technology depends on whether it’s audio, video or control. Wireless signals are affected by surrounding topology and architecture. When using wireless analog signals for audio or video, or wireless control of instruments or transfer of data, your setup must be tested on-site to assure comparable performance with the laboratory.

Casualties

UP can leave behind undesirable side effects, ranging from unwanted noise and light to unwelcome gatherings. Being mindful of the elements in relation to the specific time and place of an urban projection can help prevent unwanted encounters with residents or authorities.

Light

Projectors pointed at windows of residential buildings can disturb inhabitants. Projections near high-traffic roads can introduce confusing distractions, or blind drivers. Be mindful of inadvertent leaks or reflections from the video projectors or flashlights.

Noise

Noise from a generator, a sound system, or the performers and participants can be a nuisance to non-participants in a public space. Consider the ambient noise level of a site as well as the tolerance of its inhabitants.

Damage

UP involves a lot of movement, and moving bodies are prone to collision. Not all of the technology that lends itself to UP is designed for portability, outdoor use, dust, rain, and the effects of gravity plus hard asphalt. Consider making custom handles, carrying cases, cozies, bumpers, made of rubber, crochet, or other soft materials that serve a triple purpose: enhance portability, protect against the elements, and personalize your technology.

Roles

UP requires teamwork. Taking on different roles makes things operate smoothly, but everyone should also keep their eyes and attention on the big picture. Roles give people agency, help them make decisions that contribute to the group, and make the group operate seamlessly. In planning an UP, think through the experience of each of these characters:

- | | |
|------------------|---|
| Captain | Sees the big picture, knows the master plan, understands all of its moving parts; coordinates helpers, sets the timing, addresses authorities when necessary and wears a huge smile no matter what. |
| Wizard | Knows the technology inside and out, can connect, disconnect and debug things in the dark, always wears a head-lamp and knows where to find every little gadget. |
| Musician | Is aware of the kinaesthetic nature of up, knows that sound plays a major role in creating engaging experiences; knows that sound and music are continuous and need constant attention; takes charge of the sonic experience. |
| Time-Keep | Keeps time, takes notes, shoots pictures, records video; always documents the micro (the hands drawing) and the macro (the neighborhood all lit up with projections and people). |

- | | |
|--------------------------|---|
| Scout | Is mobile and nimble, looks ahead and follows up behind, watches out for the unforeseen and enables safe passage. |
| Helper | Is there to learn and lend a hand. |
| Super Participant | Has a real knack for performing with UP; is invested in the experience and wants to understand how it works; can help explain the UP to many others with a bit of guidance. |
| Participant | Knew about the UP and came to watch and participate in the performance, ready to interact, generate content or be projected on. |
| Audience | Knew about the UP and came to watch the performance on purpose. |
| Bystander | Found out about the UP while it was already underway; may be converted to a audience member or participant or a collaborator. |
| Neighbors | Someone may be sleeping nearby. |

Superpowers

UP empowers the performer with magic, interactivity and real-time connectivity, expansive experiences for large crowds with very little gear. In order to fully activate the superpowers inherent in the UP medium, consider the following topics for reflection and practice.

Ergonomics

Effective UP performers constantly refine the ergonomics of the instruments and how they interact with them, while paying attention to the macro-scale flow of the experience for the creator, the audience, the passerby and nearby residents. Learning to identify small elements that cause difficulty—from tension in a particular muscle in your body, to friction in how audience members move through a performance—is a superpower.

The Oz Effect

UP leverages the “Wizard of Oz” effect, described by Eruditio Loginquitas as creating big impressions through modest means. Knowing when to flaunt this control (the digital multiplier effect) and when to hide it is a super power.

Practice, Time, Repetition

Time and repetition build mastery. UP, like any complex craft, requires practice. We practice in order to perform masterfully, and also gain agility for dealing with unexpected situations. So many things can go wrong in an UP outing: flakey projectors, crashing computers, loose cables, weak batteries, missing connectors, broken cameras, cold or wet weather. With practice we learn to adapt, problem solve and improvise. Practicing enough to know how to do it with your eyes closed is a superpower.

Kinaesthetic Experiences

UP is about visual experiences, but UP experiences are also kinaesthetic—that is, they deal with the whole body and all of the senses. The powers come from how well the intervention considers and activates each sense. A sound experience added to video projection can dramatically transform the scene and sense; watching a video feels differently whether standing, seated or in motion. The audience watches the urban screen, but the performers, their costumes, and their gadgets are also an important part of the whole picture. Enriching a visual experience with complimentary sonic spatial and sensory ones is a superpower.

Openness, Flexibility, Improvisation

The city is full of the unexpected, and the unexpected can help us discover things we weren’t even looking for. For a performance on stage or in a theater, the artist attempts to have full control of every element. Remaining open to the many external forces that can reshape how things are perceived or what is even possible is a superpower.

Dealing with The Man

Despite the range of historical, legal, statistical, and anecdotal evidence that might suggest the contrary, UP can seek alliance with authority figures. Clarity of communication, purity of intention, and respect for the profession of public safety officials is critical; that starting point more often than not creates a better context for peaceful resolutions and alternative solutions. Smooth and sweet talking is a superpower.

Mobility

One of the main tricks of UP is to stay on the move. Having a mobile setup for projection lets you do several things in one night, and change scenarios if something doesn’t work out. Since there’s lots of people on the move in the city, mobility is invisibility. Refer to MUP’s Online *Vehicle Picks* for an evolving list of useful vehicles for mobile projection. Knowing how to keep moving while performing UP is a superpower.

Questions

For urban projectionists, about mixing it up:

How can you mix old sites with new places?
.....

How can you mix old technologies with new technologies?
.....

How can you mix old people with young people?
.....

How can you mix old stories with new inflections?
.....

How can you mix old school with new school?
.....

How can you mix old habits with new adventures?
.....

How can you mix fact and fiction?
.....

How can you mix theory and practice?

Questions

For artists, about working in public space:

What is our intention for this intervention?
.....

Who is this for?
.....

How do we wish the content of our work to be interpreted?
.....

How would this work be interpreted somewhere other than
the intended site?
.....

How do we wish the technology in our work to be
perceived?
.....

How would I describe my role, your role, our role in this
intervention?
.....

Who might benefit from contributing to this intervention?
.....

What potential positive consequences might we foresee?
.....

What potential negative consequences might we foresee?
.....

What experience would we create if we had infinite time
and infinite funds?
.....

How would we go about what we are doing if we weren't
artists?
.....

What do we want people to take away from their
experience?

Questions

For technologists, about making tools:

What fundamental obstacle are we trying to overcome with technology?
.....

Is technology necessary for overcoming this obstacle?
.....

Instead of making a new tool, can we combine existing tools?
.....

What would be the ideal technological solution to said problem?
.....

What would be the most accessible technological solution to said problem?
.....

Have there been other attempts at solving this problem?
.....

How can artists and other stakeholders best be involved in the design process?
.....

How can we integrate the design with feedback from the real world?
.....

How can we iterate quick solutions and trials?
.....

Can we acquire something online today that isn't perfect, but gets us going quickly?
.....

How can we design it so that other people know how to use it right away?
.....

Questions

For community members/citizens, about public art:

How do you want this neighborhood to change in the next year? next 5 years? next 10 years? What is our long-term vision for our community?
.....

How could a public art intervention benefit our community?
.....

What public spaces in this community are cherished?
.....

What public spaces in this community are troubled?
.....

Who are the most rooted and connected members in this community?
.....

Where do young people spend time in this neighborhood and why?
.....

Where do the elders of this community hang out and why?
.....

Where do you see opportunities for cross-generational knowledge transfer to occur?
.....

Where do you see opportunities for cross-cultural understanding to form?
.....

Where do you see opportunities to take on economic inequality by providing access to the underprivileged?
.....

Who would you like to involve in making this art project?
.....

Questions

For city public art officers, about site:

Who are the stakeholders in this site?
.....

What are the limitations on public action (sound, video, performance, vehicles) at this specific site? Can or should they be changed to enable expression and civic participation?
.....

What are the notable features of a site's history within the evolution of the city?
.....

What connects this site to other parts of city life?
.....

How has the site been activated by other public or private projects in the past?
.....

What stories circulate about the site?
.....

What kinds of living beings occupy the site?
.....

What can we do to make this place more desirable for public use?
.....

How can we open the site as a space for public engagement and storytelling?

Questions

For the shopkeeper, about business as usual:

What are the patterns of my everyday routine? Which do I take special pleasure in?
.....

How can my shop help art in service to my (or our) community?
.....

How can art help draw out the social qualities of this shop?
.....

What is special about the community and culture created by the shop? How can art make this visible?
.....

How can special experiences in and around my place of business transform and deepen my relationship to my customers and neighbors?

PART

3

SCENARIOS

Scenarios

MUP Scenarios offer diagrams, instructions, examples, and wisdoms intended to help you start planning and choreographing UP adventures. We've provided ten illustrated examples of how people, technology, architecture, and projected images can combine in public space to create exciting experiences. The scenarios present different possibilities of where the performers should be, where the projector should be, how the technology will be connected, what the audience will be able to see and do, and how things flow. Answering simple critical questions ahead of time helps UPists foresee potential limitations, inconveniences, and obstacles. This allows UPists to focus on the performance itself and the social interactions. It also allows for more creative play and deviation during the experience itself.

You can also create your own scenarios. The diagram icons are easily drawn by hand, so you can work out how scenarios might work with paper or chalk. **MUP Online** provides access to digital versions of these diagrams and the individual icons used to create them, allowing you to recombine and alter scenarios on the fly.

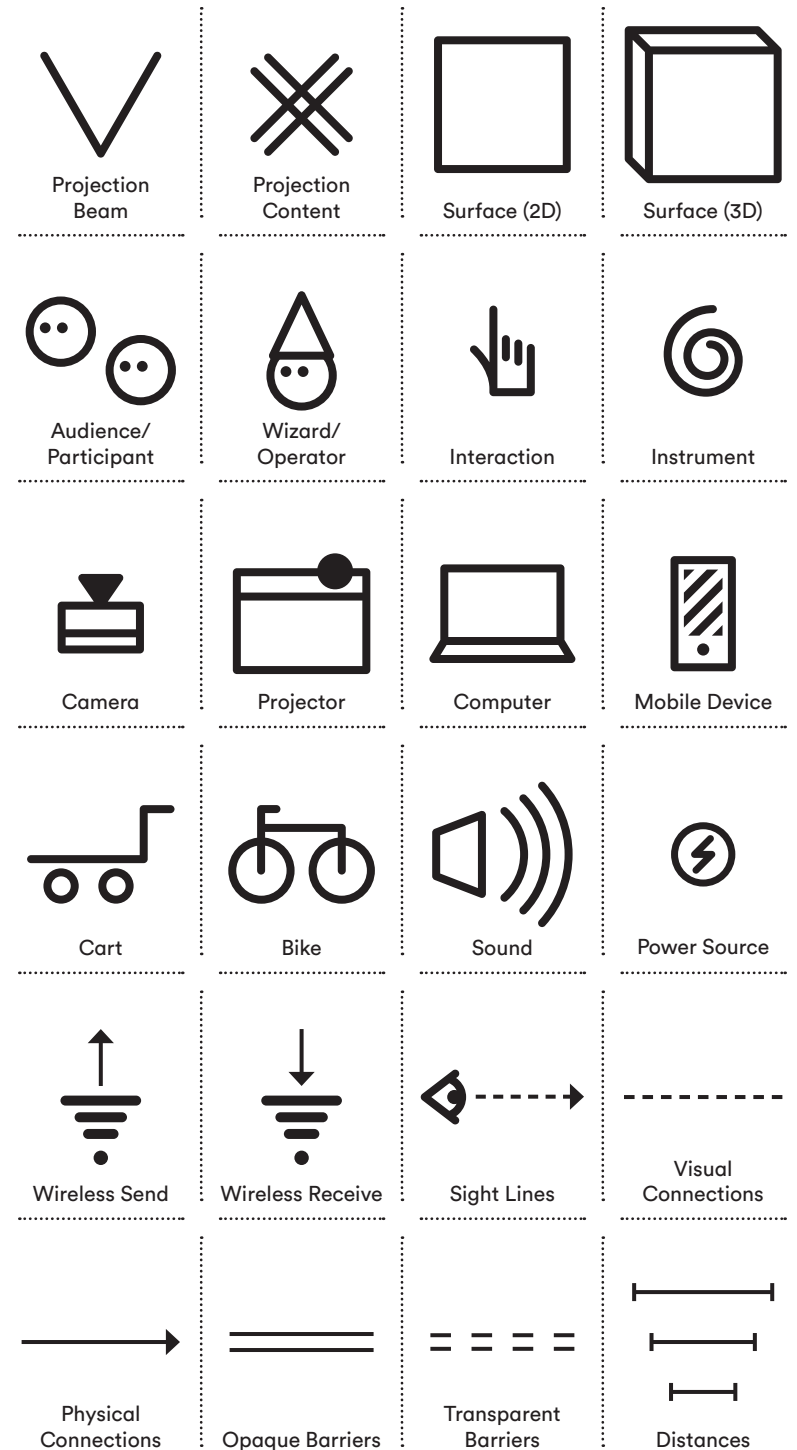

Drawing

Drawing is immediate; it lets people communicate without words. A picture can make things clear right away. Seeing someone add marks to blank paper (or an empty wall) can be a captivating and meaningful experience. In this scenario, drawing is the thing-in-between. Low-tech drawing always beats high-tech; pencils and dry-erase markers are infinitely more expressive than digital drawing tablets and touch screens.

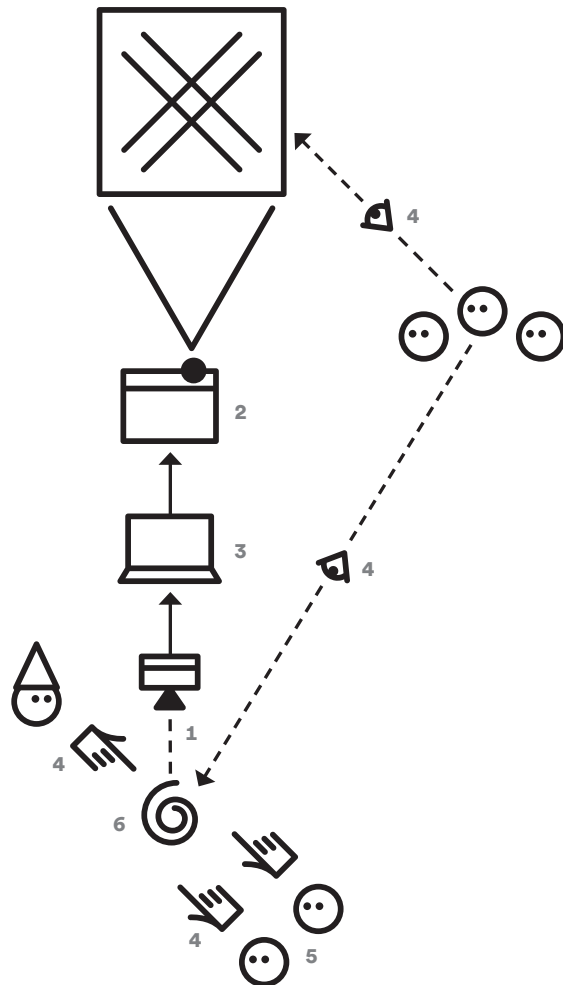

Instructions

- 1 Set-up a camera to capture the image of hands drawing on paper. You have to get the lighting right (writing light) to make it work. Soft lighting is best and several light sources help avoid shadows. Provide super-simple signs, rules, games, and instructions so people know what and when to draw.
- 2 Use a projector suited for outdoor use, and find a site where there is plenty of room to project large and small drawings, and many drawings layered on top and around one another.
- 3 Run the camera image through the computer so you can do more with the drawing. Use video projection software that can run a live feed on a laptop. The software can turn still images into animation, make video loops of hand/pen/ink movement; scale and place multiple layers of video to create more complex visual compositions; invert the image so that the white paper became the black background (dark wall), and the black ink became white (light).
- 4 Position yourself, your collaborators, and your instruments so the drawer can see the wall fully and comfortably, and people can see the projection while watching the live drawing.
- 5 Encourage collaborative drawing. Several people can develop an idea on paper in several directions at once. Use a wide-angle lens to capture a greater area and so you can work with larger pieces of paper (you'll also need much thicker markers so the camera still sees a good image).
- 6 Keep the eraser handy, so you can show people how to draw and erase quickly. Integrate the actions of drawing and erasing into the narrative animation.

Wisdom

- 1 Everyone can draw. The few who really think they can't love to watch other people draw.
- 2 Software helps turn a drawing party into performance.
- 3 Hands add character to the story: Include the hand as part of the projected image.
- 4 A 'ticking clock' helps keep things moving.

Examples

- *Eyes and Ears* <http://c-uir.org/mup/examples/no-people/>
- *Exquisite Corpse* <http://c-uir.org/mup/examples/eclm/>

Interviews

The interview format uses a camera as the thing-in-between. People like answering questions. The difference between a conversation and an interview is the camera or microphone. When a conversation turns into an interview, people can participate and engage with the subject matter more directly and publicly express their opinion.

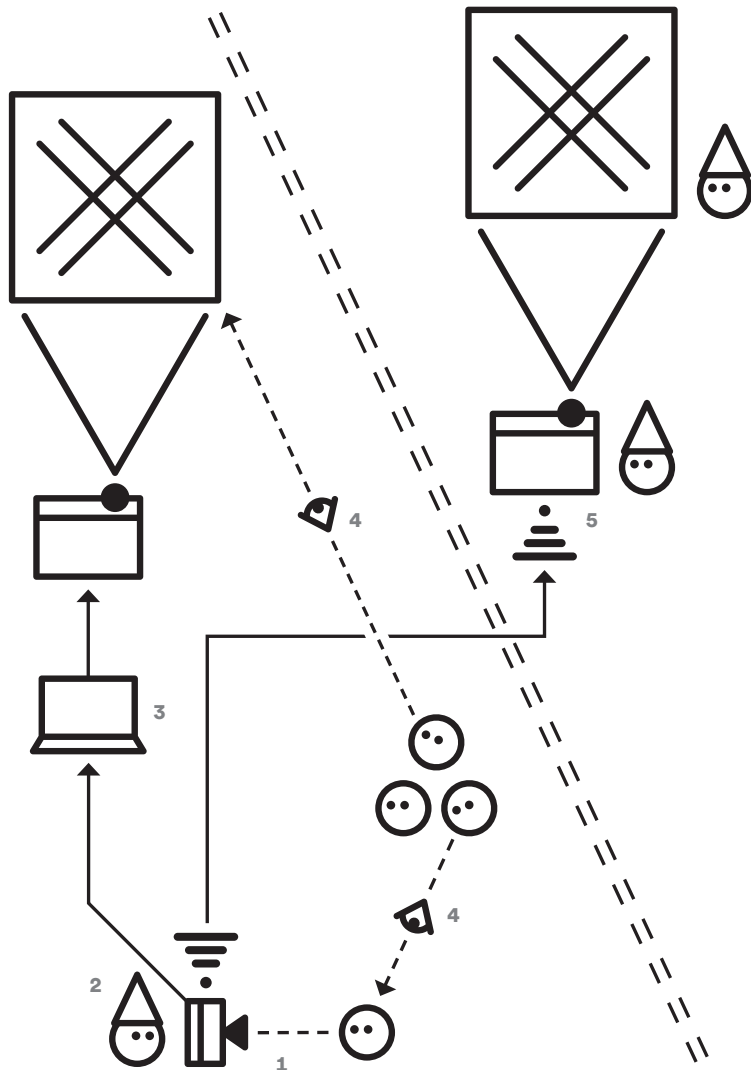

Instructions

- 1 Set up the interview situation with a camera oriented towards your subject; pay close attention to lighting as it's critical to getting a good shot.
- 2 Plan ahead with prepared questions, thinking about potential answers and where they might lead. Remain open to improvisation and deviation from said plan.
- 3 Run the camera through a computer with projection software so that you can project more than one interview at a time. Use the software to turn a series of interviews into an animated gallery of talking heads or moving bodies so that the projected image tells the passer-bys and bystanders something about what's happening.
- 4 Consider the flow of people to accommodate participating in the interview and watching the projections seamlessly. Choose a visible and accessible spot for conducting the interviews to encourage people to come close and engage.
- 5 Consider a wireless connection between the interview camera and the projections so that the entire experience can span a larger space. Give the interviewer and interviewee freedom to walk and look around.

Wisdom

- 1 Talk and listen. Curiosity is a form of generosity.
- 2 Interviewers create trust. The interview breaks down privacy barriers politely. The interview makes differences ok.
- 3 Interviews keep things coming and pay attention to pace.
- 4 Interviews can include questions and answers in the form of settings and narratives and drawings as well as words.
- 5 The human face is expressive; use camera, perspective, lighting and distance to capture subtleties in the interviewee's face.
- 6 Being asked questions makes people feel good.

Examples

- *Where Do You Call Home* <http://c-uir.org/mup/examples/where-home/>
- *Seaworthy* <http://c-uir.org/mup/examples/seaworthy/>
- *Gutless Warrior* <http://c-uir.org/mup/examples/gutless/>

Mobile Cart

Mobility offers several very important advantages in UP:

- The ability to employ trial-and-error in finding a good location and visual content.
- The ability to avoid interference with existing city infrastructure, personnel, or functions.
- The ability to reduce set-up and take-down time, especially outdoors.
- The ability to leave a site swiftly when necessary.

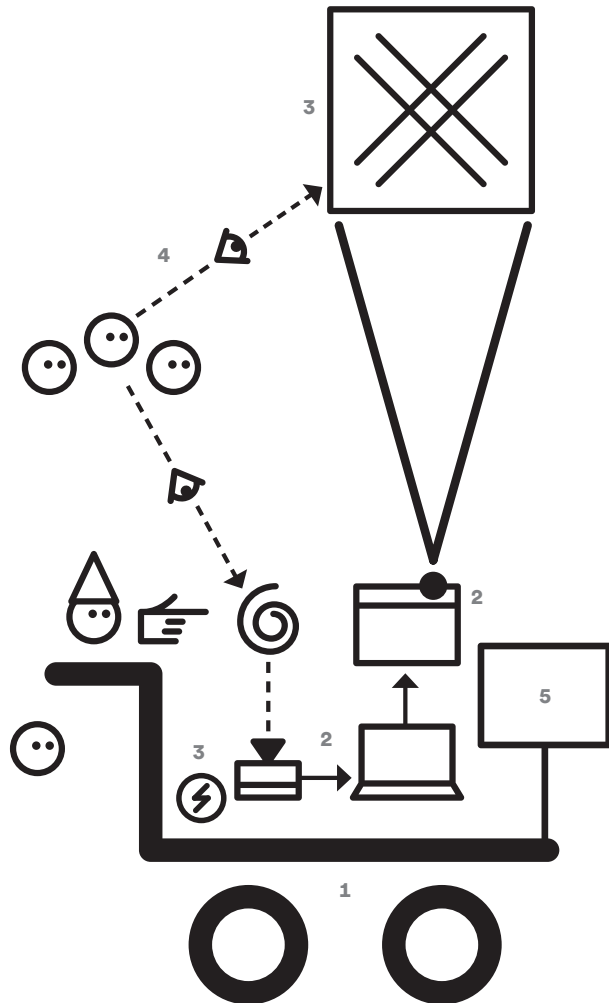

Instructions

- 1 Find a suitable cart that can carry your gear. If your cart has multiple levels, put the heaviest things in the bottom and the lightest things on top. For a smoother ride and less damage to your gear, use pneumatic wheels as opposed to hard rubber ones.
- 2 Fasten your gear to the cart: use hardware, bungee cords, cable-tie and velcro instead of duct tape, glue, and rope.
- 3 Find suitable power for your gear: batteries are much better suited to mobile setups than generators. Refer to **MUP Online's Power Picks** for recommendations.
- 4 Consider the usual utilitarian function of carts in urban spaces (street vendors, street performers, janitors, repair persons, etc); explore the characters that use them and the stories they tell as starting points for your performance.
- 5 Use custom signage to signify who you are and what you're doing projecting with this cart in a public space.

Wisdom

- 1 A designated tidy space on the cart helps interaction with the audience members go more smoothly.
- 2 The world is a stage: Lighting brings formality and attention to your mobile performance rig; uniforms and costumes make your relationship with your projection instrument more theatrical.
- 3 Handouts (giveaways) from carts are good; hand-ins (collectables) to the cart are even better.

Examples

→ *Davey's Suitcase Projector* <http://c-uir.org/mup/examples/plains>

Mobile Bike

Bicycles bring a very special form of mobility: bike culture is expanding rapidly and it brings with it better bikes, better accessories, better city biking infrastructure, a community of enthusiasts, and an overall attitude that is positive, environmentally motivated and community driven. Leveraging all the positive aspects of biking empowers UP with the cycling communities, while creating new opportunities and new audiences for UP.

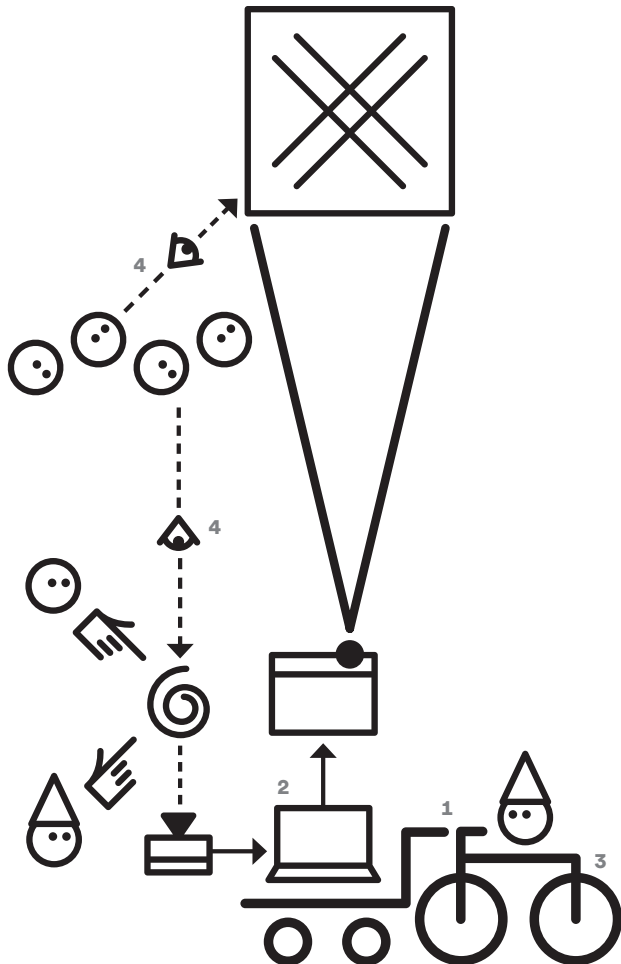

Instructions

- 1 Find a bike that is suitable for carrying your gear. Refer to *Vehicle Picks* for suggestions.
- 2 Fasten your gear to the bike. Bikes rattle so hardware works best. Cable ties and hose clamps are useful also. Avoid tape, glue and other weak and messy fasteners.
- 3 Customize your bike; customization lightens your load and creates opportunities for more efficient workflows. Customization also communicates love and care.
- 4 Consider the bike as a component of the performance stage; consider using its volume as a barrier/crowd-controller, its lights as spotlights, its body as fastening points for performance props.

Wisdom

- 1 Some people like bikes regardless of who's riding them, where they're going, or what they're carrying
- 2 Bikes can go where cars and motorcycles can not.
- 3 Bikers love to bike in groups
- 4 Projecting while moving transforms the static cinematic experience.
- 5 Cycling is not only a mode of transportation but also as a political statement; as biking supports sustainable development, environmental protection, noise and pollution control, and more livable cities.

Examples

- *MAW MakeTV* <http://c-uir.org/mup/examples/maketv/>
- *Fargo on bike* <http://c-uir.org/mup/examples/fargo/>

Computerless

Computers are wonderful and powerful tools that have forever changed the world of art practice, in particular with moving images. Nonetheless, having them involved in an UP always makes things more complicated. Analog, light-based technologies (i.e. slide projectors, overhead projectors, light bulbs, analog video cameras and wireless transmitters etc) have at least one major superpower that computers lack: they are more likely to continue working in a thunderstorm, after an internet shutdown or post-apocalypse.

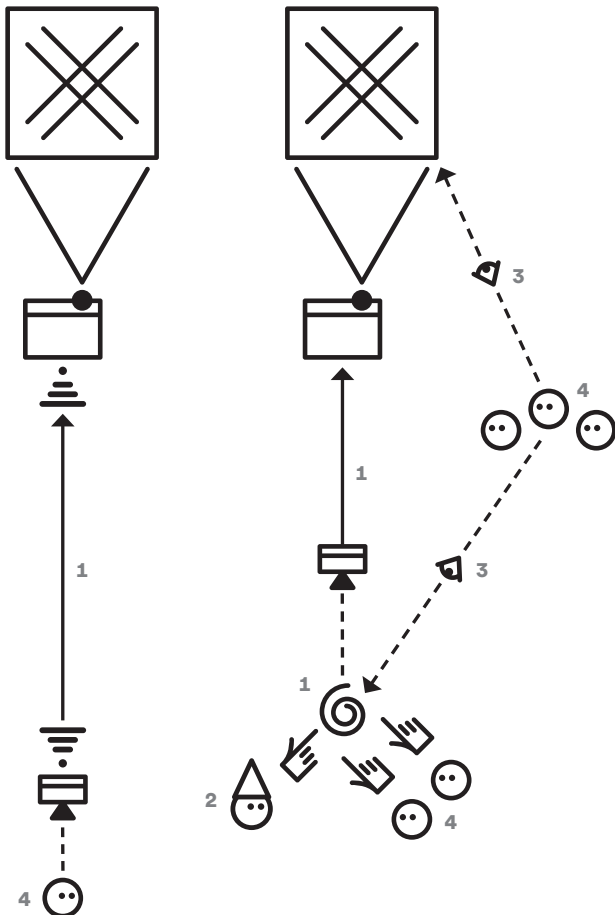

Instructions

- 1 Devise a way to realize a UP that uses live media, but not computers. Consider speakers and microphones, telephones, camcorders, slide projectors, overhead projectors, lights and shadows, mechanical typewriters, instant/Polaroid cameras, etc.
- 2 Leverage affordances, simplicity and legibility of old technologies by inviting participants to interact: if you're using a phone have people call, if you're using overhead projectors have people draw, if you're using light and shadows have people make paper cuts.
- 3 Consider the flow of people from station to station, create games and rules that clarify the order in which things happen.
- 4 Get the participants involved in not only each station (the type writing station, the slide projection station) but also in the transfer of information from one station to another (e.g. the paper from the typewriter is ceremoniously walked over from where it was written to the overhead projector)

Wisdom

- 1 Computers are powerful black boxes; black magic is attractive but clarity and transparency also speak loudly. When the audience understands the technology perfectly, they engage more with the content.
- 2 Old technologies generate cross-generational conversation: the elders remember them; the youth admire them. Both understand them.

Theater

This scenario uses the body as the thing-in-between. Theater offers a stage that combines people's bodies with the projected image. The projections can be used as dramatic backdrops, lighting, or as a way to 'zoom in' on, or to interact with the action.

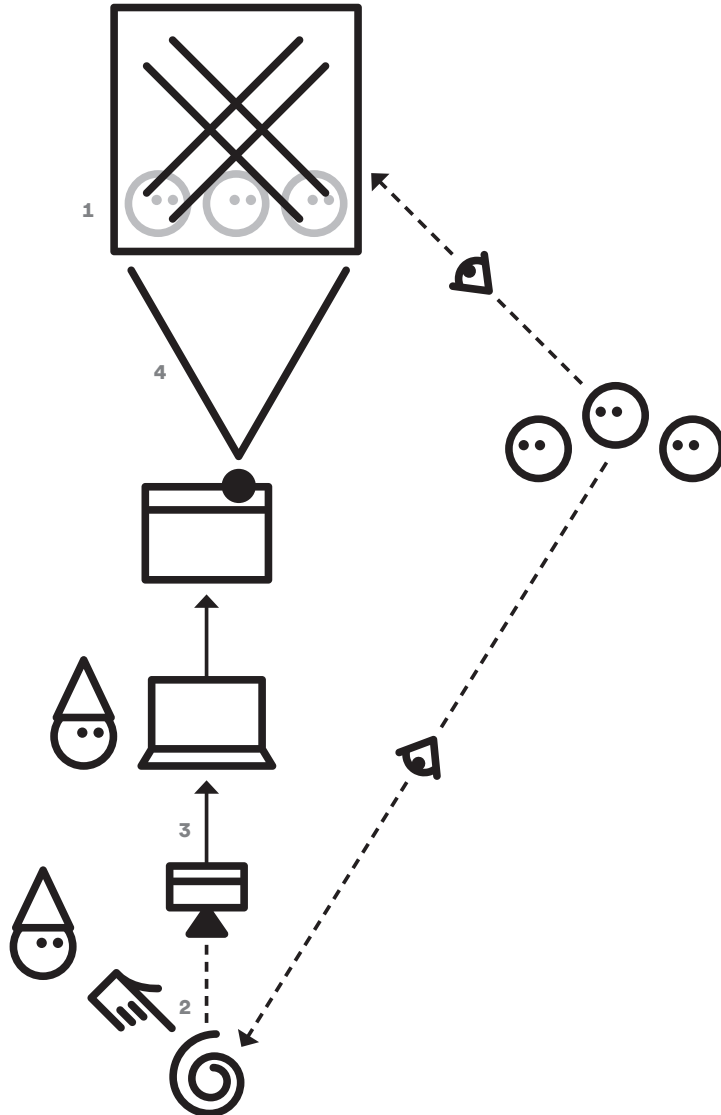

Instructions

- 1 Bodies can be instruments; bodies can be screens too. Start by projecting on and around the body.
- 2 Create a small, well-lit play-area made up of paper, markers, cutouts, wires, marbles, and other small cherishable objects. Use these tools to add elements to the projection. The play area can add another thing-in-between that the audience can understand and engage.
- 3 Use a camera to capture the image of the play area; run this image through projection software on the laptop to create video loops of performed actions. Once one loop is recorded and placed in the projection space where it goes, move on and create a new video loop layer.
- 4 Scale the video loops to the size of human bodies and project on top of people. Pay close attention to scale, and work with how the performers interact with the projected imagery.

Wisdoms

- 1 Theater thrives on the suspension of disbelief. Video projection and the theater are cousins.
- 2 A good stage can make an actor out of anyone.
- 3 The person performing is two people.
- 4 Some places already feel like stage-sets. Find a back-drop.
- 5 Playing a character, or just playing around, helps to remind us that we're capable of being a person in many different ways than we're used to.

Examples

→ B <http://c-uir.org/mup/examples/b/>

Miniatures

Taking the micro to macro is exhilarating. Magnification (with a lense, magnifying glass, microscope, digital camera) can be used as live feeds for UP. An instrument that helps people explore a much smaller scale of reality brings intrigue and joy.

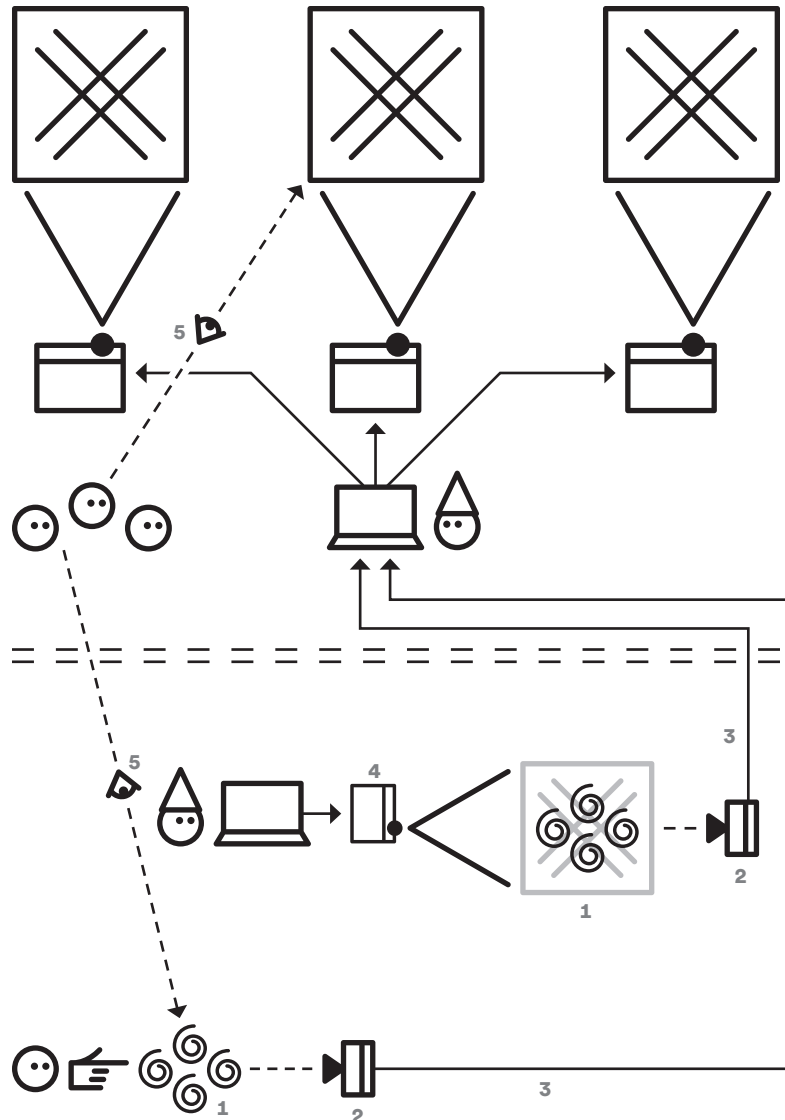

Instructions

- 1 Create a number of very small scenes out of paper, cardboard, small statues, toys, and other miniature memorabilia.
- 2 Use a camera to capture the scene. Set up bright and flexible lighting as it affects the image quality tremendously.
- 3 Send the video from the camera to a computer as a live feed in order to record, loop, layer, resize and build a complex visual composition.
- 4 Consider using a pico-projector to add projected components to your miniature scene; in which case your miniature scene has its own miniature projection in it—Metaprojections!
- 5 People can watch the miniatures at scale, or watch the projections. Set-up the miniature so that people can see it as well as the projection from the same place.

Wisdom

- 1 Accentuate translation and teleportation from one scale to another.
- 2 Magnification is enchanting, and miniatures are inherently uncanny.
- 3 When you are bigger than the world, you can see it as a system.
- 4 An elaborate and intricate miniature world full of many stories can fit in a small suitcase: You can bring it with you.
- 5 The order in which people discover the various interconnected elements dictates the narrative trajectory of the experience.

Examples

- *Slam Janes* <http://c-uir.org/mup/examples/slam-janes/>
- *Chicken Love* <http://c-uir.org/mup/examples/chickenlove/>
- *Minidisasters* <http://c-uir.org/mup/examples/minidisaster/>
- *Battle of Everyouth* <http://c-uir.org/mup/examples/bey/>

Dioramas

Dioramas are scale models of organisms or landscapes that highlight interesting behaviors, historical events, nature scenes or cityscapes. This scenario combines real world still-lives with projected video to create additional layers of storytelling.

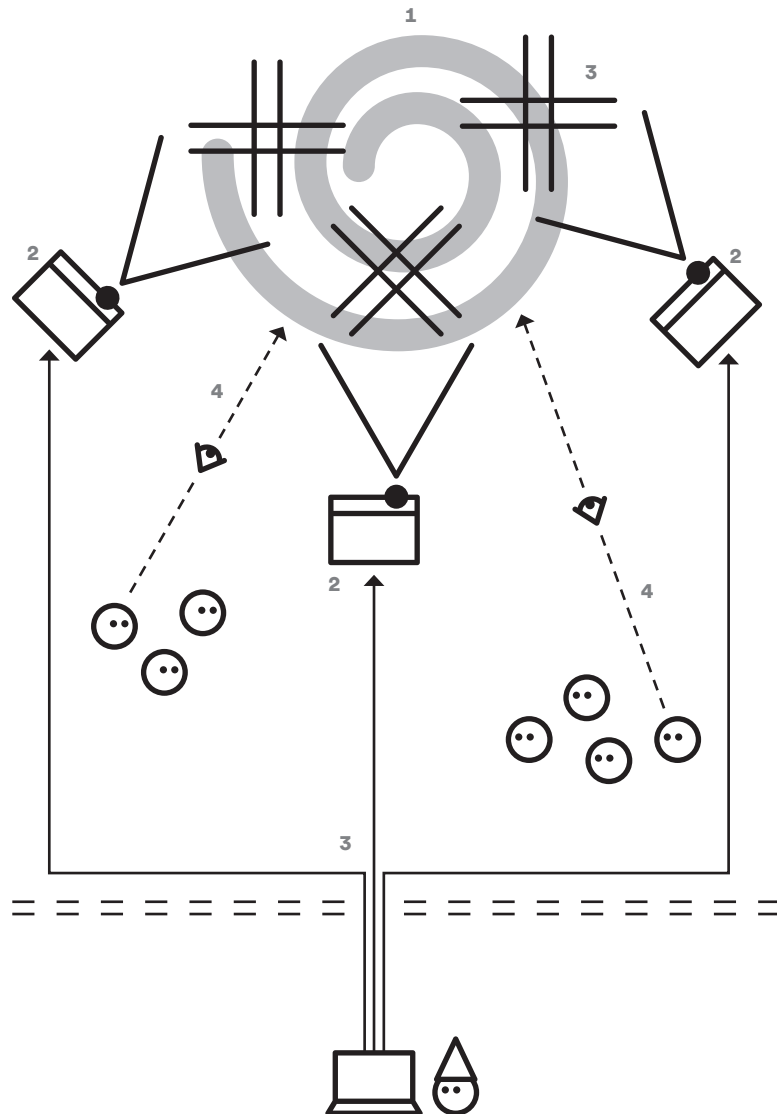

Instructions

- 1 Start with an existing still life; a painting, a sculpture, statues, lonely public art, an usual store-window, or a diorama. Find inspiration for content and story in the history of the object, people's memories of the object, as well as your imagination for how this object could be transformed.
- 2 Use projection software to create multiple layers of video projection that interact with the physical features of the still life; look for software that facilitates projection mapping—allowing the projectionist to warp the layers of video in particular ways so that they appear flat and natural on the screen.
- 3 Be very aware of the scale of the object, in relation to the scale of the projected layers of imagery. Look for the smallest scale of detail/ornament in the object and match it in the projection; also assess the largest/architectural scale of the object, include a layer of projection that functions at that scale. When working with larger monuments or numerous diorama, use multiple projectors connected to one computer to cover more area and enter the physical scale of the monument.
- 4 People already know how to look at paintings, sculptures, statues and dioramas. Add projection in a way that does not detract from the basic elements of the experience; mount the projectors high or out of site so that people could still gather around the object, point at it, walk around it, or see it from far away.

Wisdom

- 1 The surface you project onto is part of the content.
- 2 A good diorama is at once perfectly still yet always in motion in our imagination; moving light on a static object can accentuate this perceptual and cognitive effect.
- 3 Dioramas commemorate a cherished time and place; A projection on a diorama can bring this celebration into the present moment.
- 4 A diorama combines nature, archive and theater; consider projection content that also pursues this combination.

Example

→ *Animal Warmth #12* <http://c-uir.org/mup/examples/animal-warmth-12>

Ghosts

When we don't know the source of something, we are reminded of the limits of being human. Something bigger than us emerges in forms we can't see and don't understand. From far away, something unknown has the power of mystery. Einstein, when confronted with physical forces beyond his understanding, described the phenomenon as "spooky action at a distance."

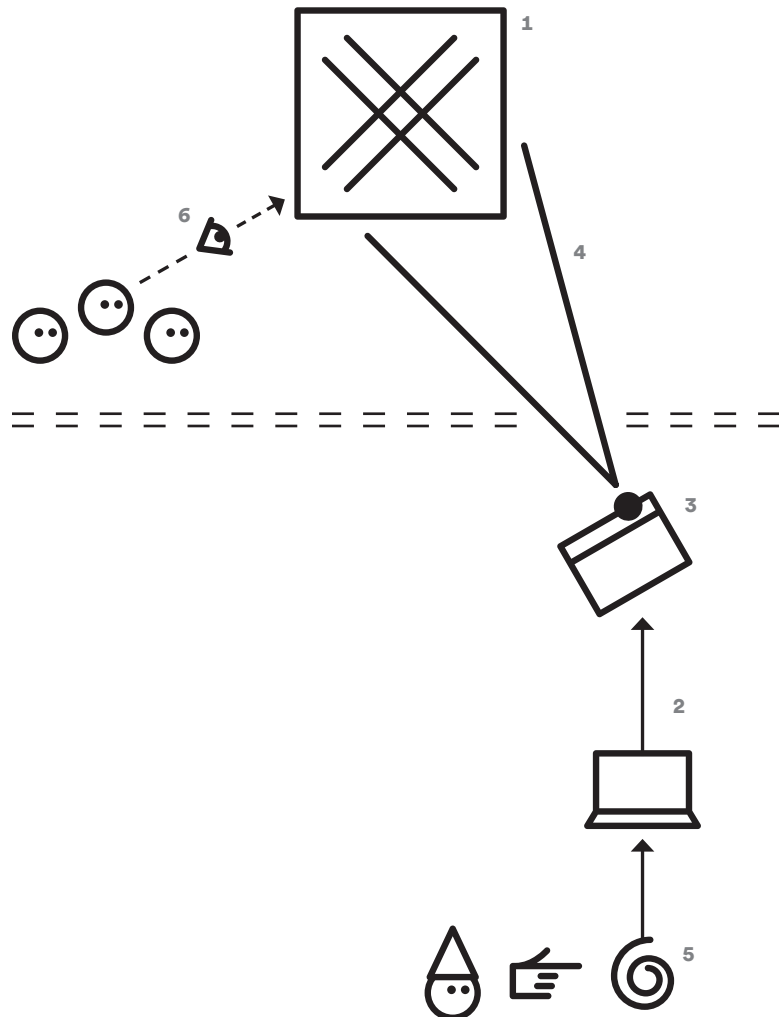

Instructions

- 1 Find a site that is ideal for UP; monumental structures, visible from far way, with a constant flow of people, and ambient lighting that can be turned off. A bridge, a tower, an abandoned urban warehouse enormous exposed walls, a city monument demanding commentary, an empty billboard.
- 2 Identify a place from which you can project onto the site without being seen; this location can be far away, or behind something, or near the top of a nearby building.
- 3 Keep the lens of the projector out of sight by moving back a few feet away from the window or opening. It's the bright spot of the lens that's visible from far away.
- 4 Project from an un-expected angle and correct for the key-stoning distortion with the projector's settings or projection mapping software. People expect projections to come from directly in front of the image.
- 5 Instead of preparing GIFs, JPGs, and movies, consider a camera with marker and paper as the medium. This allows you to interact with the video projection in real-time, match its scale, and play with architectural features.
- 6 In a ghost projection you often end up projecting from a suboptimal location; use projection software to have real-time control over the image's appearance (e.g. brightness, contrast, color, key-stoning, etc.) so as to optimize how good it looks.

Wisdom

- 1 Anonymity is a superpower, the invisible is omnipotent.
- 2 The telephone is the most forgotten form of wizardry. Remote control is the most forgotten form of the magic wand.
- 3 Telepresence (when someone from far away appears nearby) reminds us of our multifinitude (how we could end up in so many different places).

Example

- *State Crisis* <http://c-uir.org/mup/examples/galata/>
- *Hole in Space* <http://c-uir.org/mup/examples/a-hole-in-space/>

Games

Games provide a context for shared engagement in an activity that carries meaning but not burden. Games provide rules for interactions between people; this makes it easier for people to jump right in and do something together. UP can communicate informational aspects of a game, like who is playing and how the game works. UP can also organize the dynamic elements in a game, like score-keeping, time-keeping, and boundary lines.

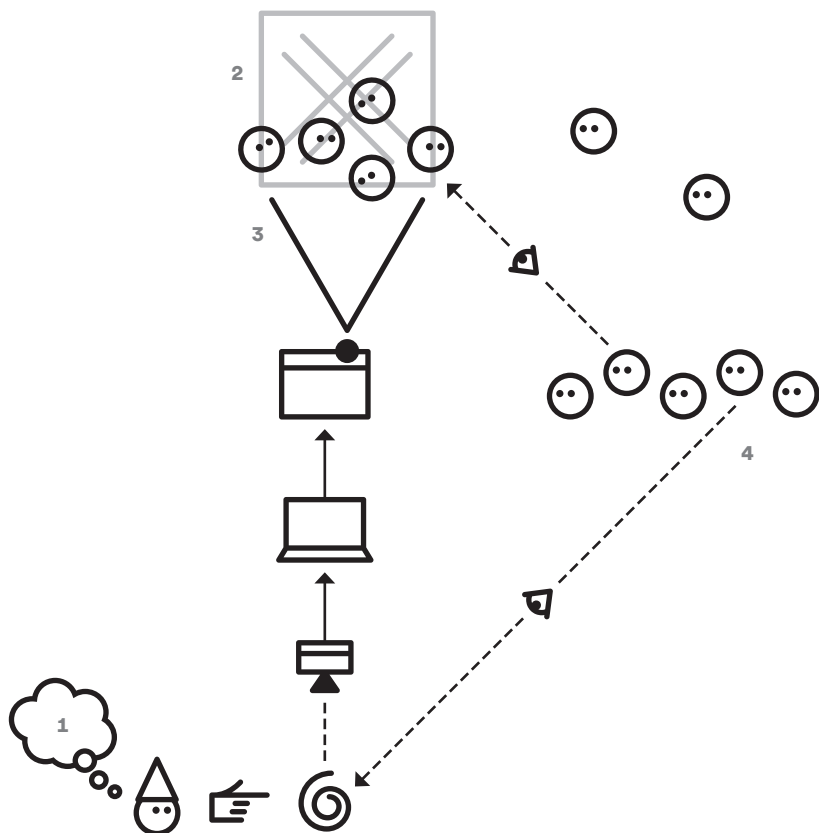

Instructions

- 1 Think of a game that can be played in public space with bodies interacting with a video projection. The rules of the game must be clear from the projection alone; project step-by step instructions if necessary. Learn from the design of your favorite board or card games. Try it with Hangman where the alphabet is projected as a list that people can point to, and the hangman is hand drawn; try it with hand drawn mazes with choreographed instructions that people can see, read, and follow.
- 2 Choose a site that invites play. It could be a playground, or an abandoned lot—some place where people aren't afraid to watch or be watched. Arrange the projection to function at the scale of human bodies moving about. Look for a set-up where several people can all be covered by the projection from head-to-toe, and are also able to see more projected images behind and above them.
- 3 Be the referee. Use a projected image as the main medium of communication between you and the players. Use a live camera feed to capture your hands and what they're doing. Draw, build things with small objects, make lines with matchsticks, and project that image in order to interact with space. Use these tools to convey the rules of the game, keep the score, signal whose turn it is, and keep the game going.
- 4 Participatory projection games are pick-up games: audience members can quickly become players and vice-versa; learn to plan ahead for how people will take turns, or how one player can teach a new player how to play.

Wisdom

- 1 Everybody loves a good game
- 2 The design of a game can reinterpret the dynamics of competition and collaboration.
- 3 Grown-ups like to play like children and children like to pretend to be grown-ups.
- 4 Games provide a context for shared engagement in an activity that carries meaning but not burden.

Examples

- *Wall games* <http://c-uir.org/mup/examples/wall-games/>
- *The Parade* <http://c-uir.org/mup/examples/the-parade>

Collective

People like to do activities together and learn from each other. Collective action scenarios provide opportunities for competition, teamwork, and surprising interactions. Only one person at a time can use a computer's mouse and keyboard, but many people can send it information. Many new gadgets can track our gestures (e.g. computer cameras, mobile phones, game controllers) and send the tracking information to a computer; the computer can then respond to that information through changes in the projected image. People can learn how to play by watching others, as they do with carnival games or video games.

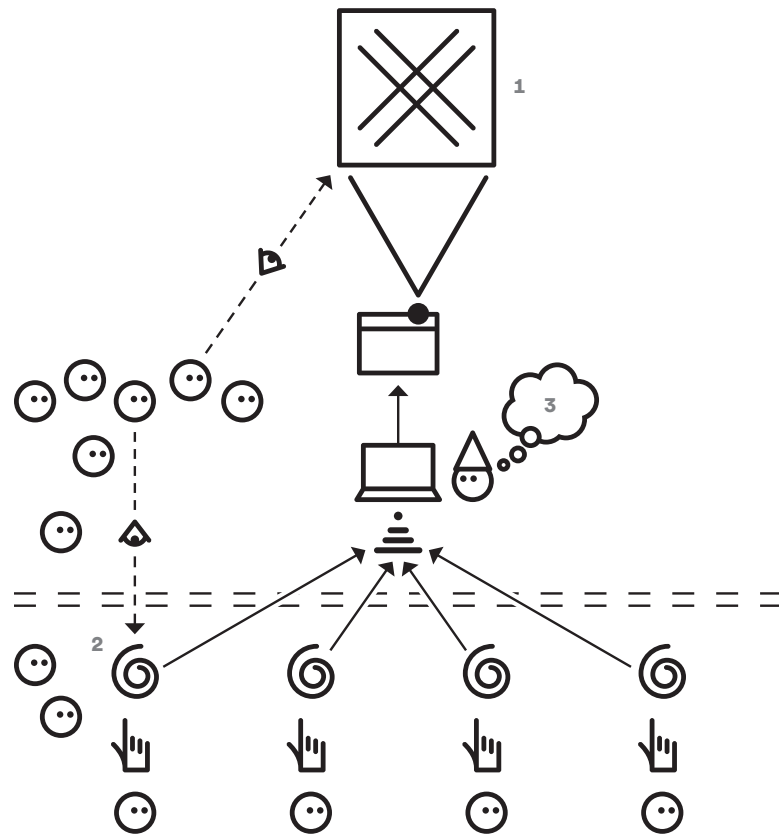

Instructions

Collective takes working together as the thing-in-between.

- 1 Invent a story with many moving parts that allow many people to participate. Employ metaphors like: building something magnificent; destroying a shared enemy; performing variations on a theme; or collective brainstorming.
- 2 Find a tool that lets several people send information to the computer simultaneously; video game consoles and their multiple controllers do this by design; mobile phones with special software can send data to a single computer; social media tools like Facebook, Twitter, Google Hangout or Skype bring people together on a single browser screen.
- 3 Use projection software to create visualizations and generate animations based on what the participants are doing with their hands and bodies.

Wisdoms

- 1 Seeing your individual contribution to a collective venture builds confidence in yourself and in your community. You get to see yourself as part of a whole, and a whole is better than the sum of its parts.
- 2 When many people are learning something at once, everyone is a teacher and a student at the same time.
- 3 When no one person is "in charge," more people feel free to experiment.
- 4 In a participatory performance, working with and working against others can be playful.
- 5 Collective work is best when it is "instantly knowable, infinitely masterable" (Levin + Snibbe).

Examples

- *Urban Echo* <http://c-uir.org/mup/examples/urban-echo>
- *Fargo Dancers* <http://c-uir.org/mup/examples/plains>

Project Example 1: Statuevision

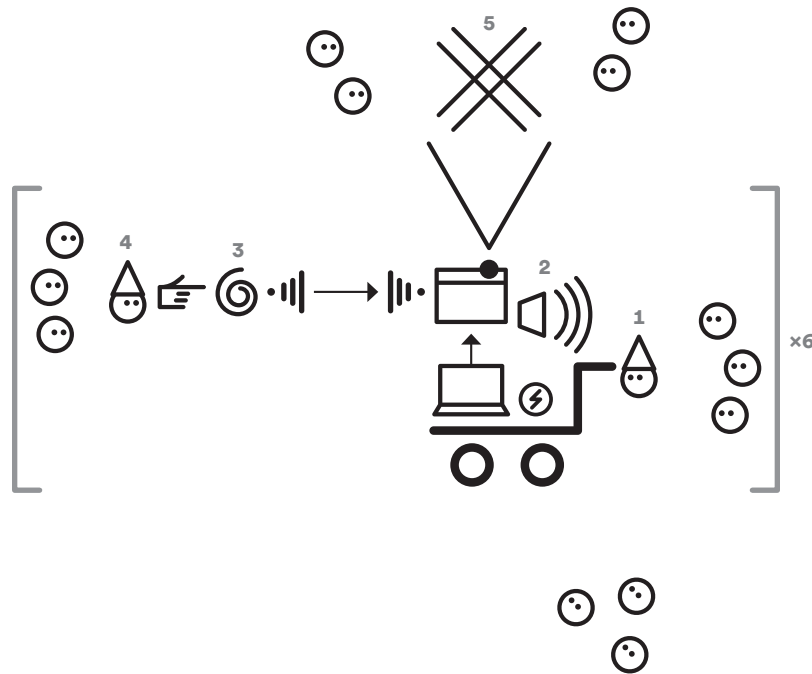

Instructions

Statuevision focuses on cross-generational interaction around teaching, learning and playing.

- 1 Assemble a cart that can carry a power source (e.g. car battery), sound system, computer and project.
- 2 Use this cart to project site-specific content in historically and culturally significant locations in a city. Statuevision worked with animated 3d renderings of statues in Washington DC's public spaces.
- 3 Devise a way to interact with the projections so you can animate them like a puppeteer animates a puppet. Statuevision used mobile phones to control movements of animated 3d statues.
- 4 Devise a conversational scenario where young people can teach old people things. Statuevision worked with 7–8 year Montessori students who studied the districts historical statues and taught the audience about these significant figures and their contemporary counterparts during the performance
- 5 Be creative with what counts as a viable projection surface; Statuevision projected statues on the grounds and trees of Dupont Circle. With help from some real-time exposure, scaling and placement control, and some dynamic animation, the imagery was legible even when projected at odd angles onto trees.

Wisdoms

- 1 Involving school children makes every public project more likable for the audience, more exciting for the performers, and more meaningful for everyone.
- 2 Doing things right in public spaces takes a lot of communication and collaboration, and communication and collaboration demand time.
- 3 There's power in numbers; in planning a public performance considers multiples as a way to assure variation, redundancy, pleasant surprises.

Example

→ *Statuevision* <http://c-uir.org/projects/statuevision/>

Project Ex. 2: Battle of Everyouth

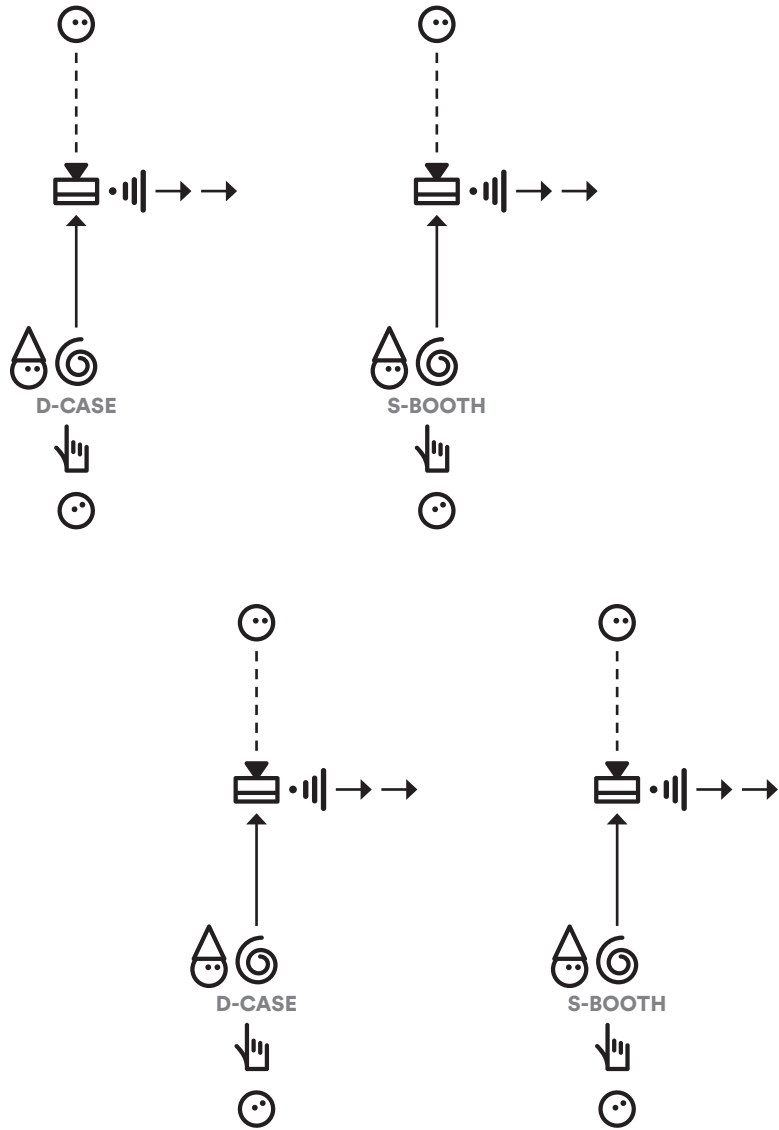

Example

→ *Battle of Everyouth* <http://c-uir.org/mup/examples/bey/>

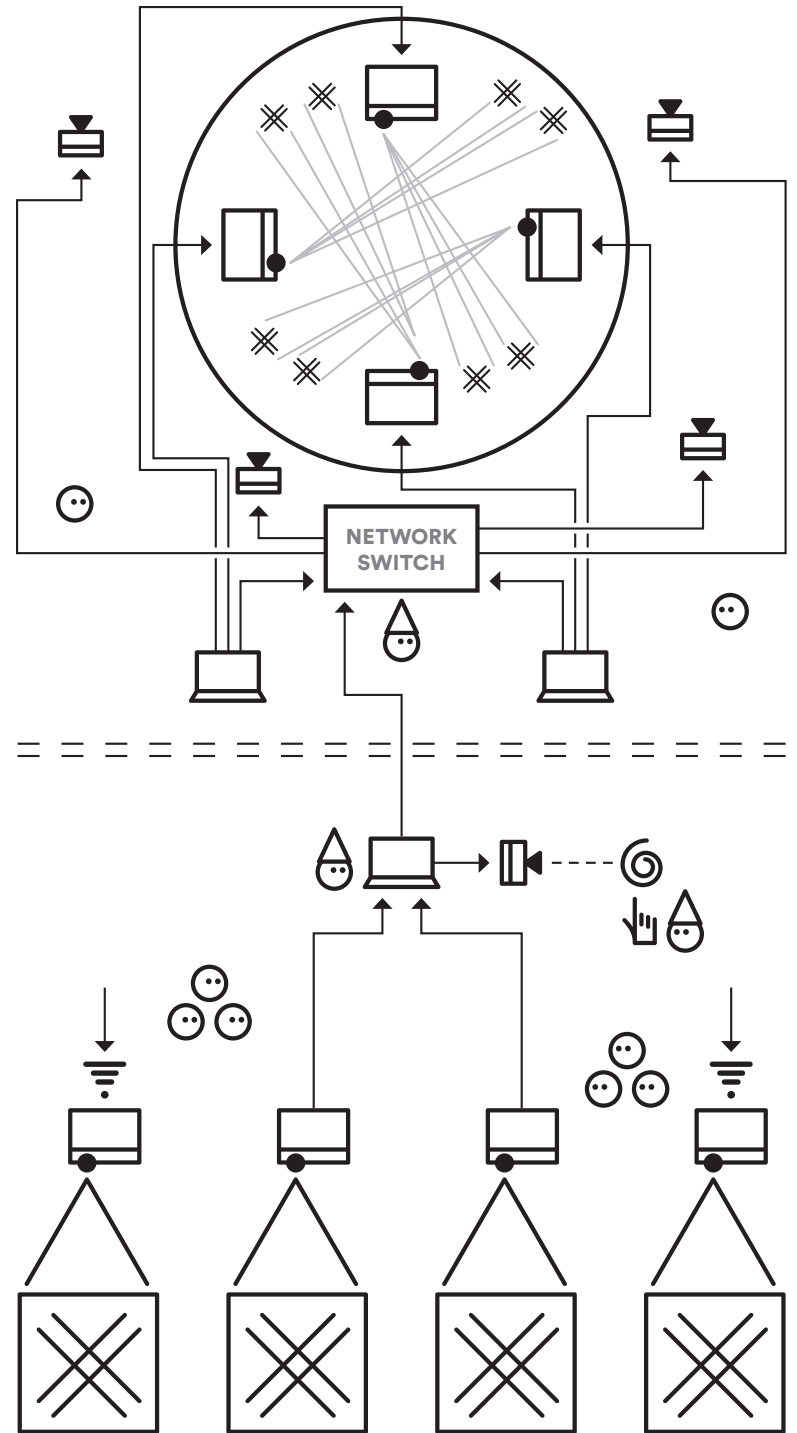

PART

4

RESOURCES

Readings

For further reference on concepts, we recommend the following books

- 1 ***A Thousand Plateaus: Capitalism and Schizophrenia***
Gilles Deleuze and Felix Guattari
- 2 ***Society of the Spectacle***
Guy Debord
- 3 ***Situationist International Anthology***
Edited and translated by Ken Knabb
- 4 ***On the Passage of a Few Persons Through a Rather Brief Unity of Time***
Guy Debord/Bureau of Public Secrets

Places/ People

- 5 ***Public Art: Theory, Practice, and Populism***
Cher Krause Knight
- 6 ***The Social Life of Small Urban Spaces***
William H Whyte
- 7 ***The Death and Life of Great American Cities***
Jane Jacobs
- 8 ***The Poetics of Space***
Gaston Bachelard

Light/Image

- 9 ***The Cradle of Humanity: Prehistoric Art and Culture***
Georges Bataille
- 10 ***The Emancipated Spectator***
Jacques Ranciere
- 11 ***Staging the Screen: The Use of Film and Video in Theatre***
Greg Giesekam
- 12 ***Education for Socially Engaged Art***
Pablo Helguera

Systems/Senses

- 13 ***Building Systems, Design, Technology and Society***
Edited by Kiel Moe and Ryan E. Smith
- 14 ***Things That Make Us Smart: Defending Human Attributes in the Age of the Machine***
Don Norman
- 15 ***The Tyranny of Structurelessness***
Jo Freeman
- 16 ***Entropy Demystified: The Second Law Reduced to Plain Common Sense***
Arieh Ben-Naim

Play/Work

- 17 ***Free Play: Improvisation in Art and Life***
Stephen Nachmonovich
- 18 ***Instantly Knowable, Infinitely Masterable***
Golan Levin
- 19 ***Critical Vehicles: Writings, Projects, Interviews***
Krzysztof Wodiczko
- 20 ***Finite and Infinite Games***
J P Carse

Stories/Experiences

- 21 ***The Practice of Everyday Life***
Michel De Certeau
- 22 ***The Never-Ending Story***
Michael Ende
- 23 ***It was Like a Fever: Storytelling in Protest and Politics***
Francesca Polletta
- 24 ***On the Origin of Stories: Evolution, Cognition, and Fiction***
Brian Boyd

MUP Online

The printable version of MUP is accompanied by a downloadable version [<http://c-uir.org/MUP>], and a series of evolving resources for UP tools and techniques.

These resources include:

Project Picks

<http://c-uir.org/picks/software>

Software Picks

<http://c-uir.org/picks/software/>

Projector Picks

<http://c-uir.org/picks/projector/>

Camera Picks

<http://c-uir.org/picks/camera/>

Game Picks

<http://c-uir.org/picks/game/>

Controller Picks

<http://c-uir.org/picks/controller/>

Vehicle Picks

<http://c-uir.org/picks/vehicle/>

Cutouts

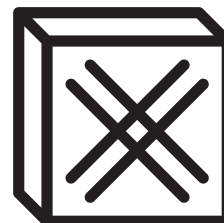
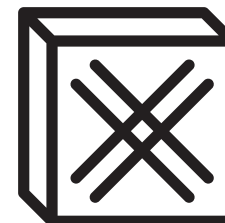
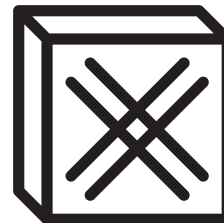
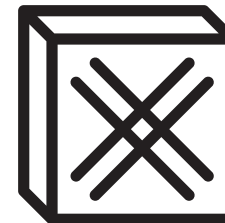
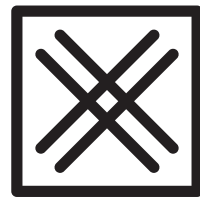
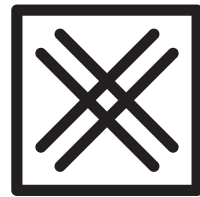
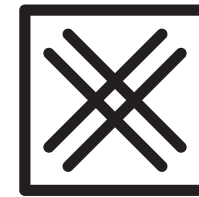

<http://c-uir.org/MUP>

Projection Content	Projection Content	Projection Beam
Projection Content	Projection Content	Projection Beam
Projection Content on 2D Surface	Projection Content on 2D Surface	Projection Beam
Projection Content on 2D Surface	Projection Content on 2D Surface	Projection Beam
Projection Content on 3D Surface	Projection Content on 3D Surface	Projection Beam
Projection Content on 3D Surface	Projection Content on 3D Surface	Projection Beam

Cutouts

Audience/Participant	Audience/Participant	Audience/Participant
Audience/Participant	Audience/Participant	Audience/Participant
Audience/Participant	Audience/Participant	Audience/Participant
Audience/Participant	Audience/Participant	Audience/Participant
Audience/Participant	Audience/Participant	Audience/Participant
Audience/Participant	Audience/Participant	Audience/Participant

<http://c-uir.org/MUP>

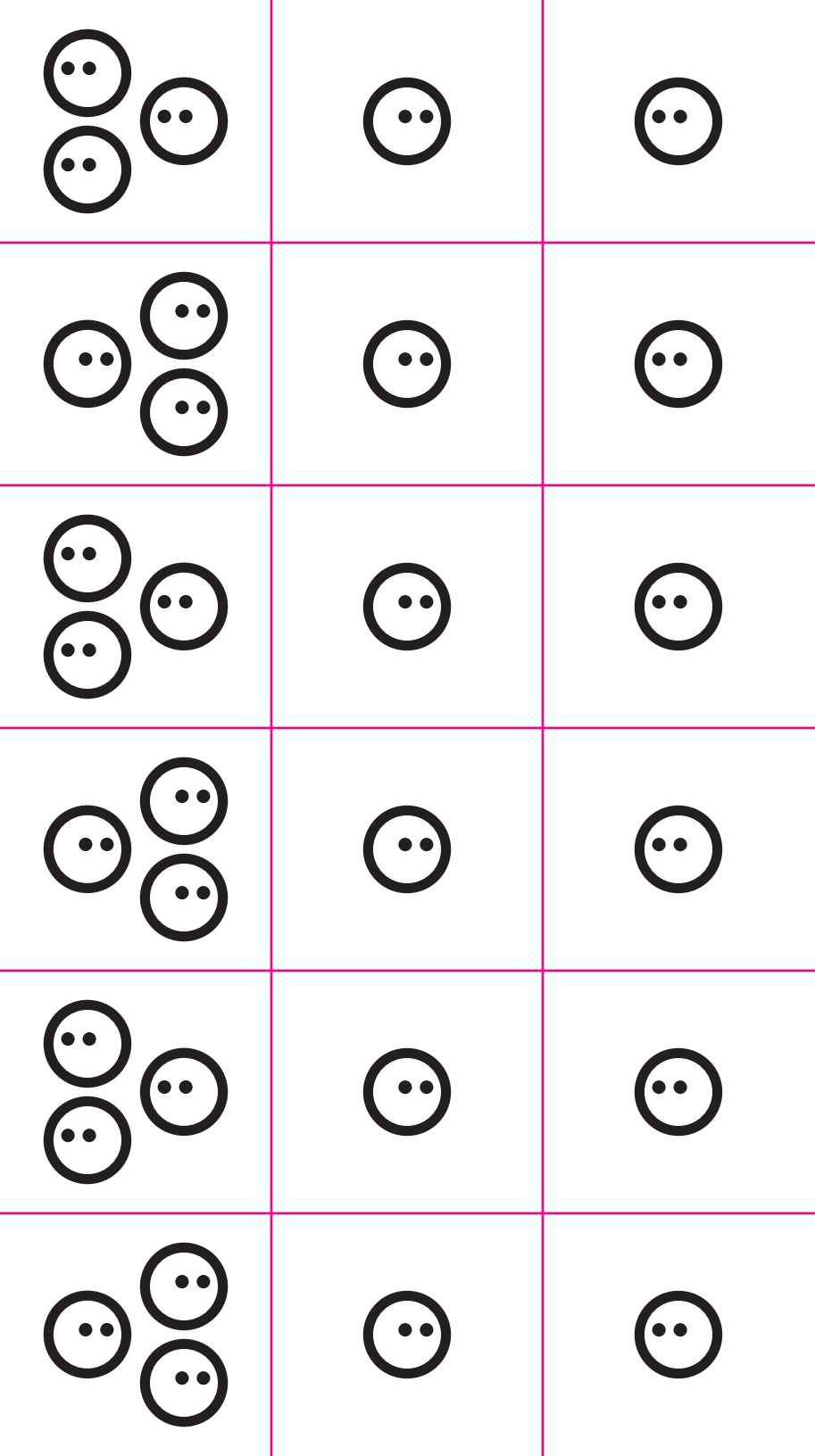

<http://c-uir.org/MUP>

Cutouts

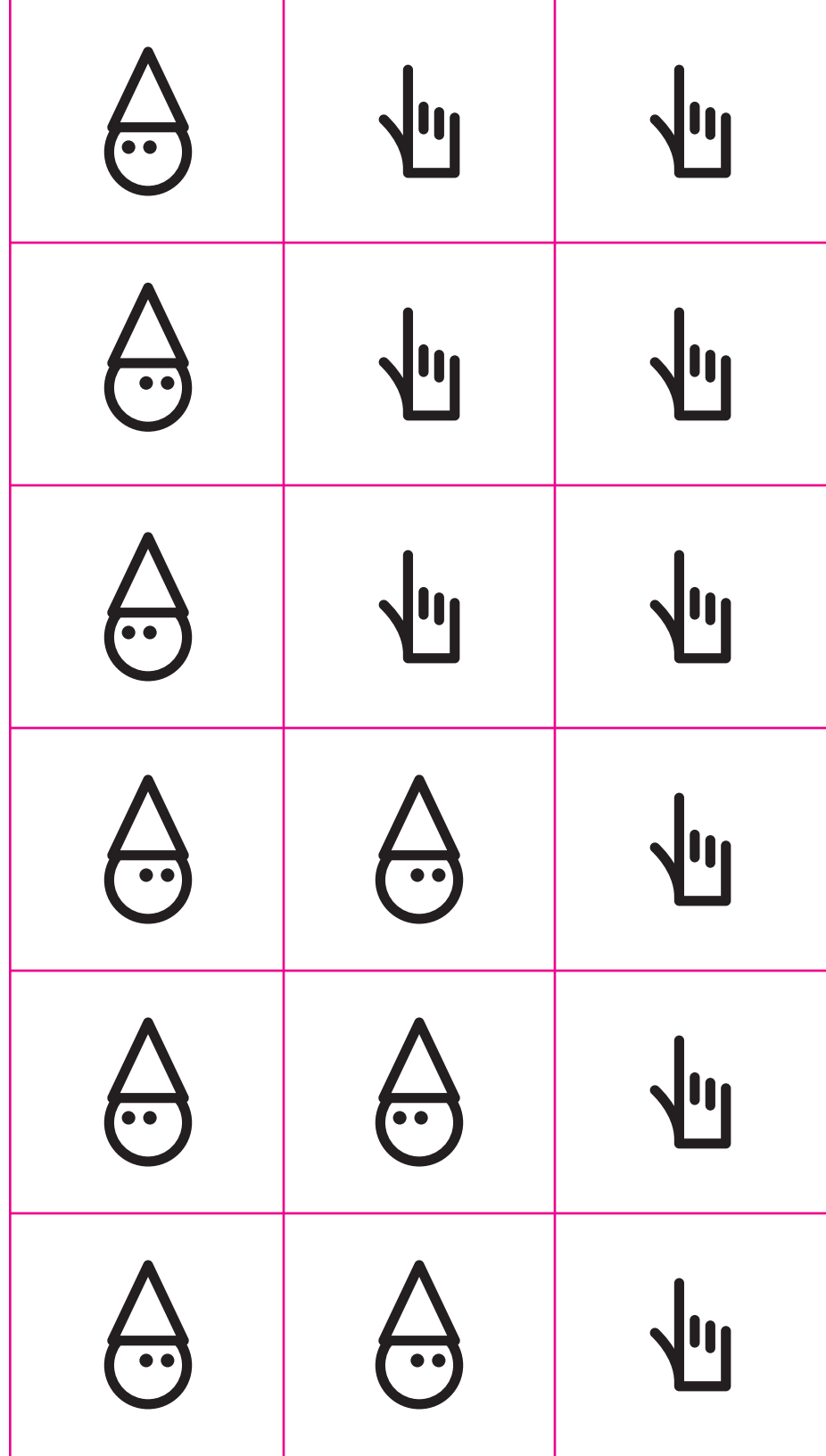

Interaction	Interaction	Wizard/Operator
Interaction	Interaction	Wizard/Operator
Interaction	Interaction	Wizard/Operator
Interaction	Wizard/Operator	Wizard/Operator
Interaction	Wizard/Operator	Wizard/Operator
Interaction	Wizard/Operator	Wizard/Operator

Cutouts

Camera	Instrument	Instrument
Camera	Instrument	Instrument
Camera	Instrument	Instrument
Camera	Camera	Instrument
Camera	Camera	Instrument
Camera	Camera	Instrument

<http://c-uir.org/MUP>



Cutouts

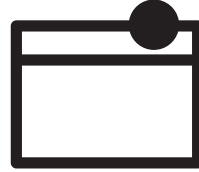
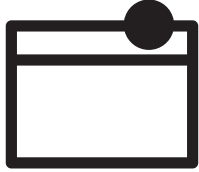
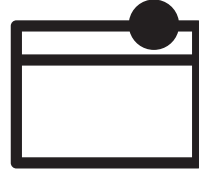
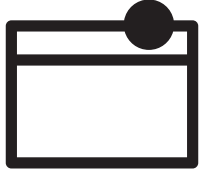
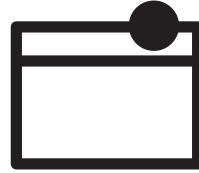
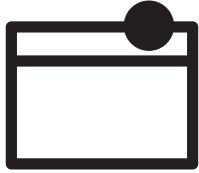
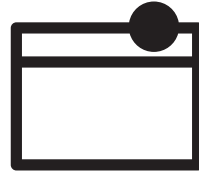
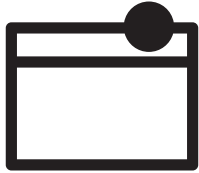
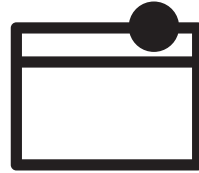
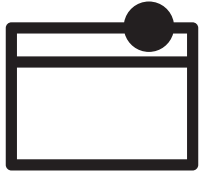
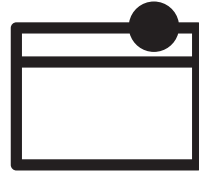
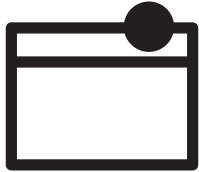

<http://c-uir.org/MUP>

Computer	Projector	Projector
Computer	Projector	Projector
Computer	Projector	Projector
Computer	Projector	Projector
Computer	Projector	Projector
Computer	Projector	Projector

Cutouts

Cart	Mobile Device	Computer
Cart	Mobile Device	Computer
Cart	Mobile Device	Computer
Cart	Mobile Device	Computer
Cart	Mobile Device	Computer
Cart	Mobile Device	Computer

<http://c-uir.org/MUP>



Cutouts

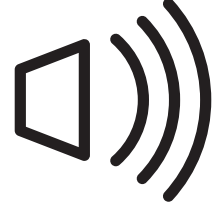
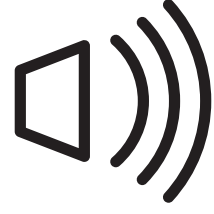
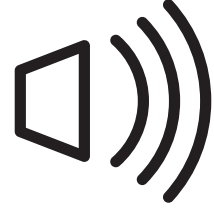
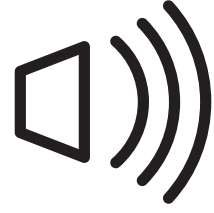
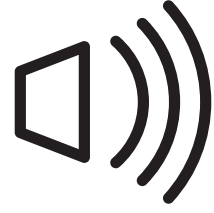
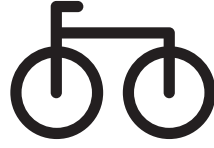
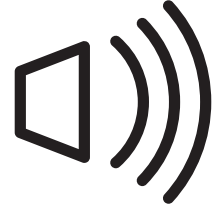
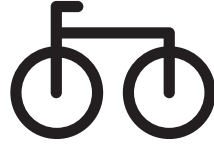

<http://c-uir.org/MUP>

Power Source	Sound	Bike
Power Source	Sound	Bike
Power Source	Sound	Bike
Power Source	Sound	Bike
Power Source	Sound	Bike
Power Source	Sound	Bike
Power Source	Sound	Bike

Cutouts

Sight Lines	Wireless	Wireless
Sight Lines	Wireless	Wireless
Sight Lines	Wireless	Wireless
Sight Lines	Sight Lines	Wireless
Sight Lines	Sight Lines	Wireless
Sight Lines	Sight Lines	Wireless

<http://c-uir.org/MUP>